

WARRANTY

We strive to offer high-quality products, and we also try our best to satisfy each and every customer that orders from us with product or service as needed.

Each customer must provide a record of their order such as the order number, or item receipt for any items that are out of the warranty period you may also still receive replacement parts by purchasing them with our company if they are available.

**Are you having difficulty
with assembly? Missing parts?**

Please contact us : info@firststopintl.com

telephone No.:5627813327

send email with your order No. to

**For return, please check the return policy with
the retailer or market place you bought from.**

Appreciate your purchasing from us.

Pop up your life by our furniture !

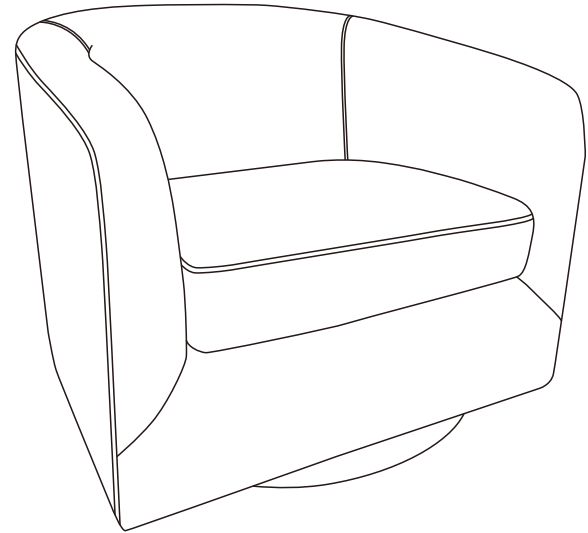
The logo for Wixé, featuring the word "wixé" in a bold, lowercase, sans-serif font. The letter "i" is stylized with a grey dot and a vertical grey bar extending downwards.

ITEM NO. CH0030

NOTE:

This brochure contains IMPORTANT safety info. Please read and keep for future reference.

MAINTAINANCE AND WARNING

- Keep furniture away from heat and fire.
- Keep furniture away from sharp objects.
- Do not clean furniture with harsh cleansers or polish. Do not use detergents, Solvents, abrasives, spray packs or leather cleaner. Use non-color mild soap with warm water clean spills(Mix 1:10 soap to water)
- Do not place furniture under direct sunlight, material will possibly fade over time.
- Do not jump or strike on the furniture.
- Do not write on furniture without a padded barrier to protect the surface.
- Not for commercial use, For residential use only.



Weight Limitation

400LBS

PARTS LIST

A*1

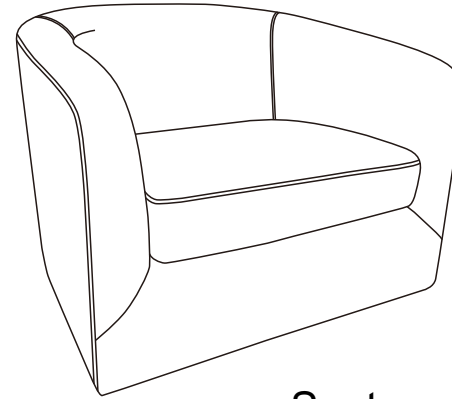

Seat

B*1

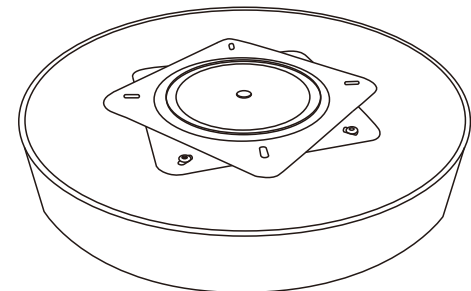

Rotary base

HARDWARE and TOOL LIST

①*4

M6*45mm



Bolt

②*1

M6



Allen Key

SPARE

①*2

M6*45mm



Bolt

Be sure to check all packing materia fit the packing list. Carefully for smallparts, which may have come loose inside the carton during shipment.

ASSEMBLY INSTRUCTIONS

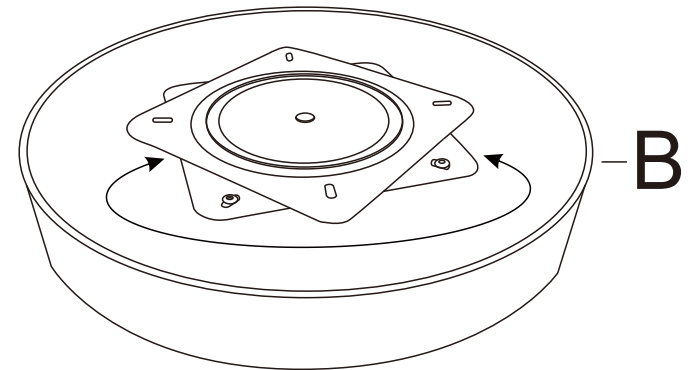

Can be rotated 360°
Swivel

STEP 1: Rotate the swivel on Rotary base B to the position shown.

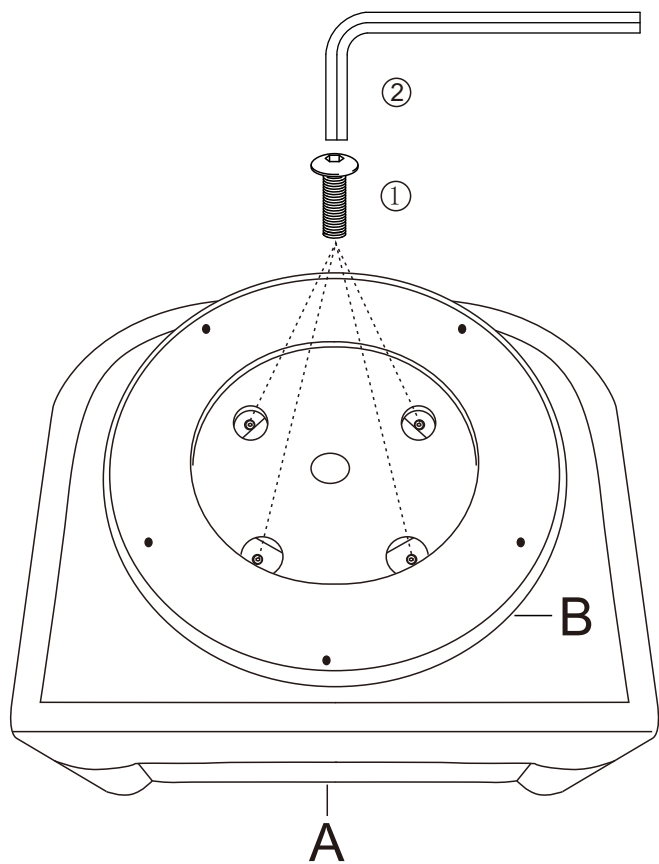

STEP 2: Turn the seat frame A upside down on clean padded surface.
Use bolt #1, allen key #2 to attach Rotary base B on the seat A, fasten all bolts to secure.

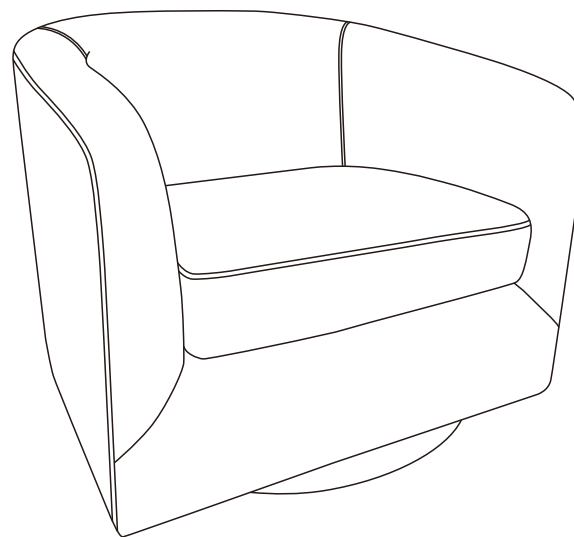

STEP 3: Assembly completed.