

NOTICE

*Please make sure that you have all parts indicated and they are in good condition before you begin assembly of this item. Refer to part list and hardware list below for guidance.

*This item should be assembled on a soft surface to prevent scratching the finish during assembly.

*This item may require periodic tightening.

*If you are having difficulty, our friendly Customer Care team is always here to help. Please email customersupport@safavieh.com.

PREPARATION

* Before beginning assembly of product, make sure all parts are present. Compare parts with part contents list and hardware contents list.

* If any part is missing or damaged, do not attempt to assemble the product.



* Estimated Assembly Time: 10 minutes.

***Tools Required for Assembly (included): Allen Key**

CARE AND MAINTENANCE

Insert Care and Maintenance here

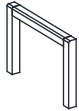
Part List and Hardware List

PIECE	DESCRIPTION	PICTURE	QUANTITY
A	Table Top		1X
B	Frame Leg		2X
HW1	Screw: M6x0.5x55 mm	 6x55	6X
HW2	Allen key	 LG4	1X



Model# PAT7095

Product Dimensions: 23.62" W x 40" D x 15.9" H

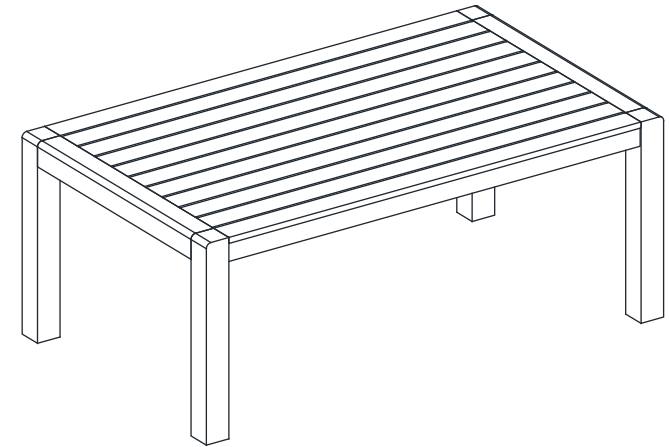

Weight Capacity : 40 lbs

Warning : Do not stand on table

Warning : Do not over torque bolts / screws

PREPARATION

- *Before beginning assembly of product, make sure all parts are present. Compare parts with package contents list and hardware contents list.
- *If any part is missing or damaged, do not attempt to assemble the product.
- * Estimated Assembly Time : 10 minutes.
- * Tools Required for Assembly (included): Allen Key
- * If you are having difficulty, our friendly Customer care team is always here to help. Please email customersupport@safavieh.com

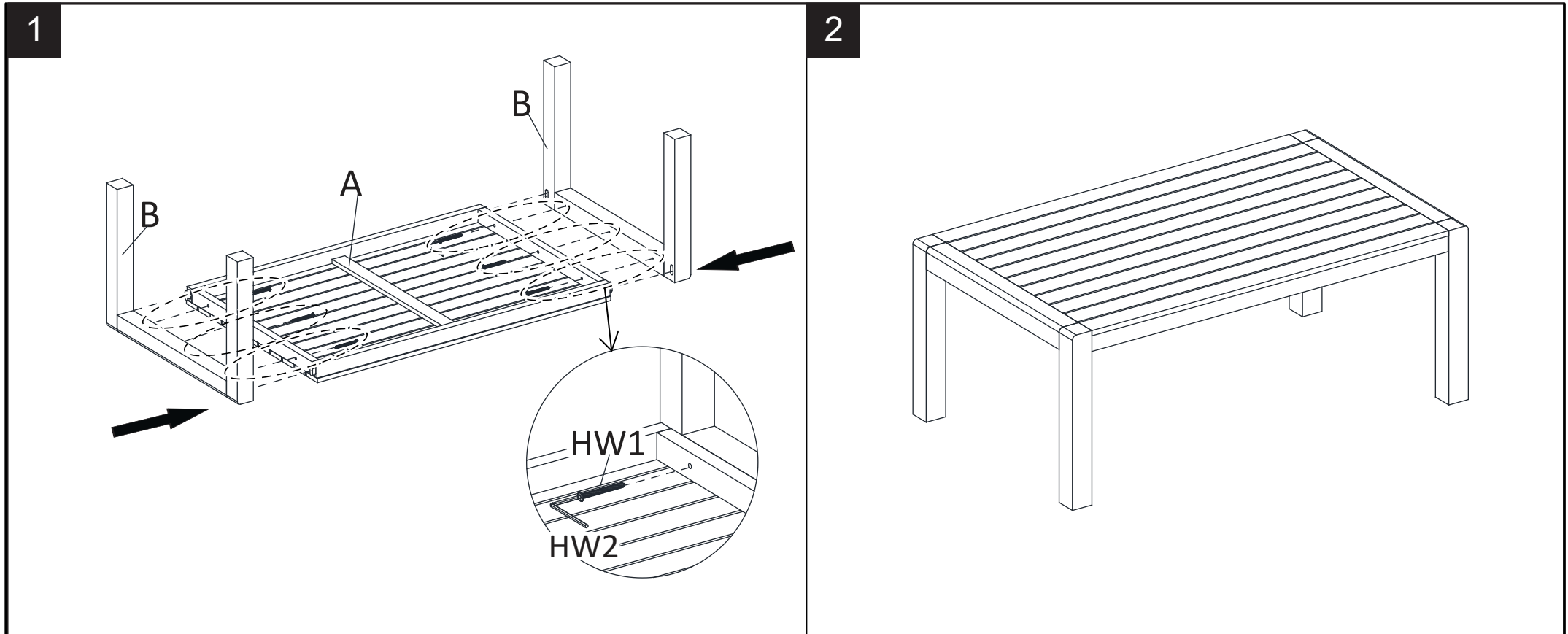

Step 1

Place the Table Top (A) (bottom-side up) onto a clean, soft surface to avoid any scratches or damage to the product.
- Attach Leg frame (B) to Table Top (A), Use Screws (HW1) and tighten by allen key (HW2), as shown above

Step 2

Turn the Table right side up
Ensure all bolts are fully locked into position.
The Table is ready to be used.