

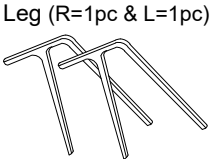









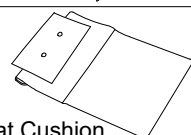
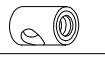
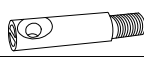
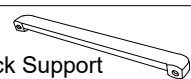
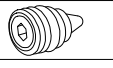
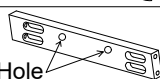

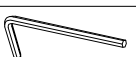
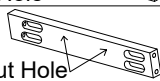
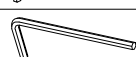

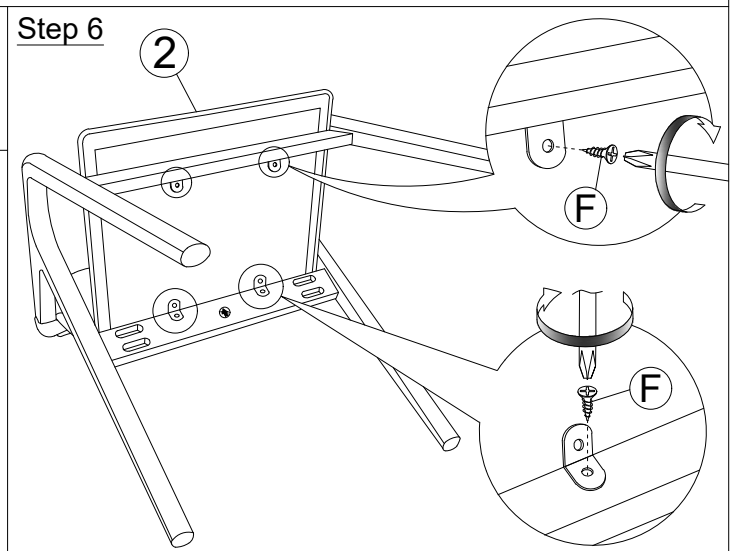
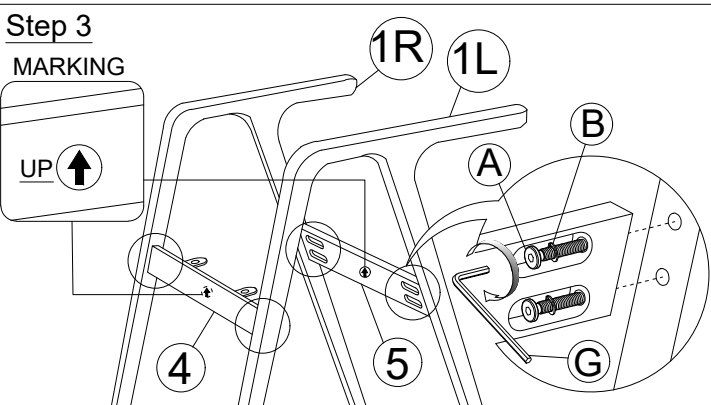
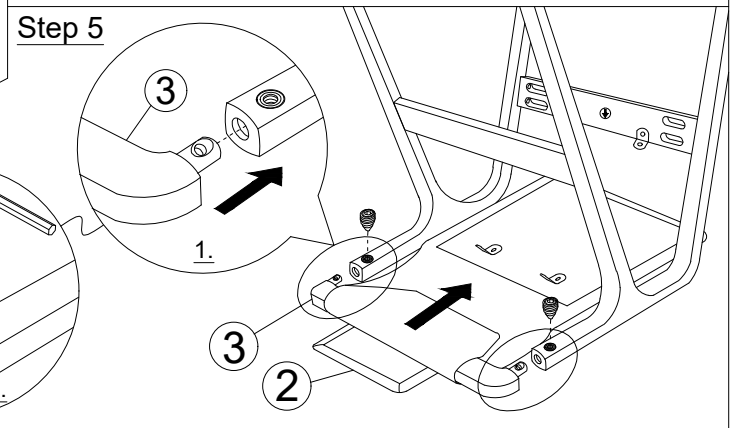
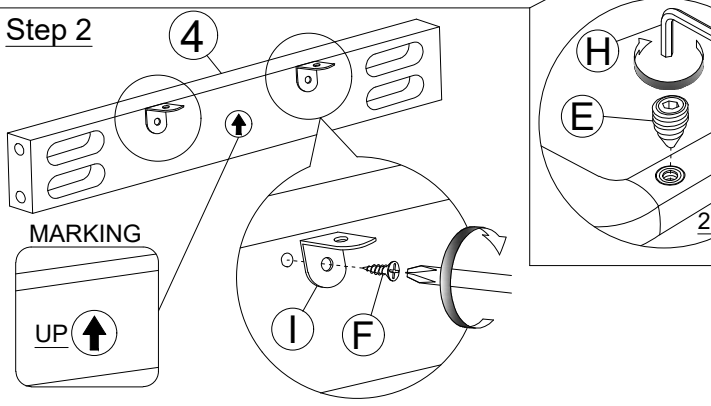
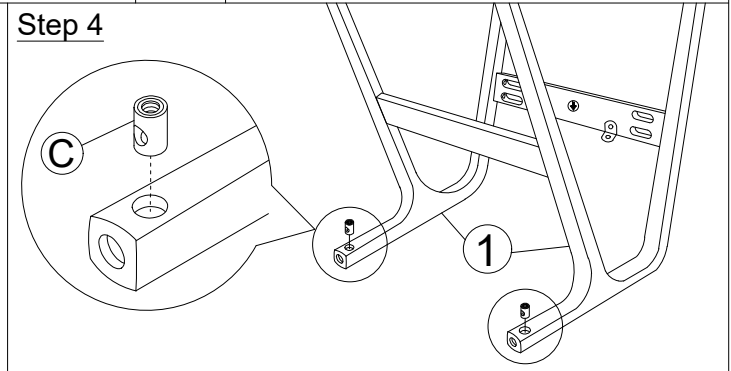
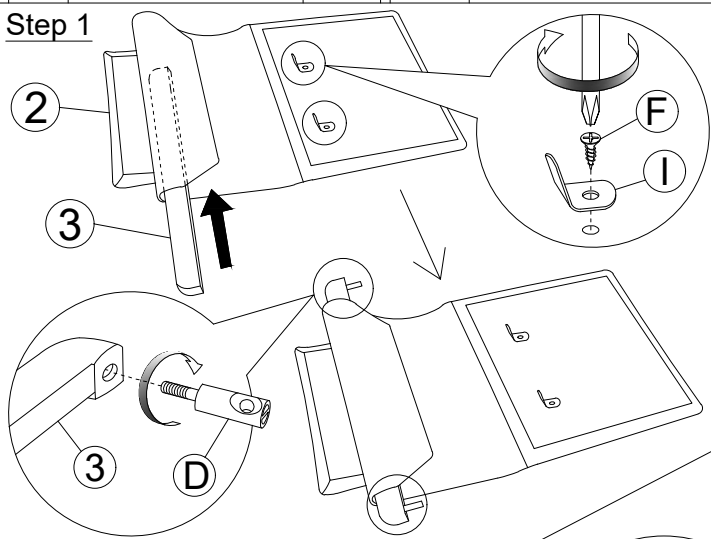
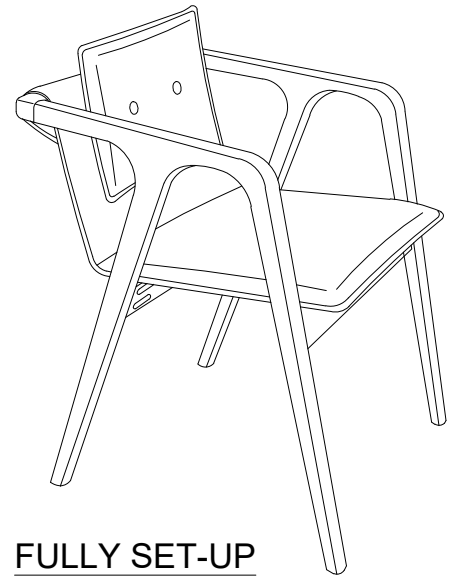

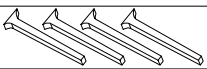
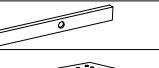

# ASSEMBLY INSTRUCTIONS

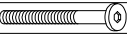
ITEM	HARDWARE NAME	QTY	ITEM	HARDWARE NAME	QTY
1	Leg (R=1pc & L=1pc) 	2 PCS	A	JCBC BOLT M6 X 45 mm 	8 PCS
			B	SPRING WASHER M6 	8 PCS
2	Seat Cushion 	1 PC	C	BARREL NUT (Short) 	2 PCS
			D	BARREL NUT (Long) 	2 PCS
3	Back Support 	1 PC	E	BARREL NUT LOCK 	2 PCS
4	Apron With Hole 	1 PC	F	CSK SCREW M4 x 12 mm 	8 PCS
			G	ALLEN KEY M4 	1 PC
5	Apron Without Hole 	1 PC	H	ALLEN KEY M5 	1 PC
			I	BRACKET 	4 PCS

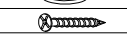
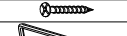

# ASSEMBLY INSTRUCTIONS

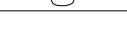
ITEM	PART LIST	QTY
1	Table Top 	1 PC
2	Table Leg 	4 PCS
3	Leg Support 	2 PC
4	Table Base 	2 PCS
5	Table Support 	2 PCS

ITEM	HARDWARE LIST	DESCRIPTION	QTY
A	JCBC Bolt M6 x 50 mm		4 PCS
B	JCBC Bolt M6 x 40 mm		8 PCS
C	WOOD DOWEL M8 X 30 mm		8 PCS
D	Spring Washer		12 PCS
E	Flat Washer M6 x 13mm		12 PCS
F	CSK M4 x 30 mm		10 PCS
G	CSK M4 x 13 mm		6 PCS
H	Allan Key		1 PC
J	Wood Button 14.5		4 PCS



## STEP 1

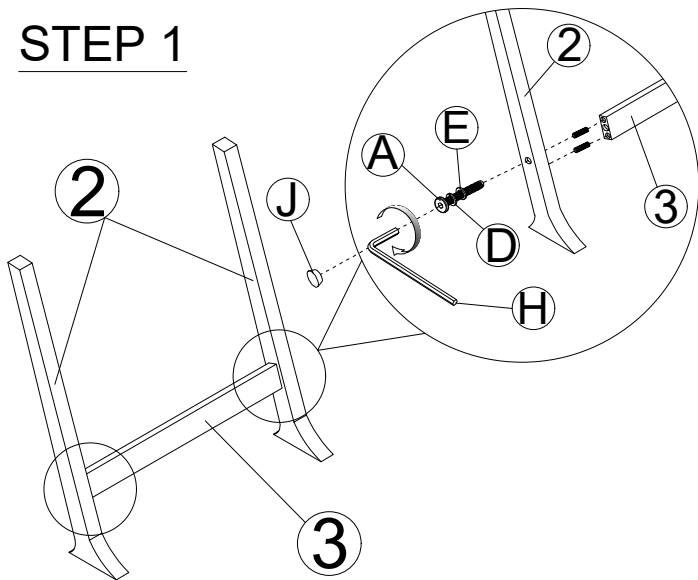

## STEP 2

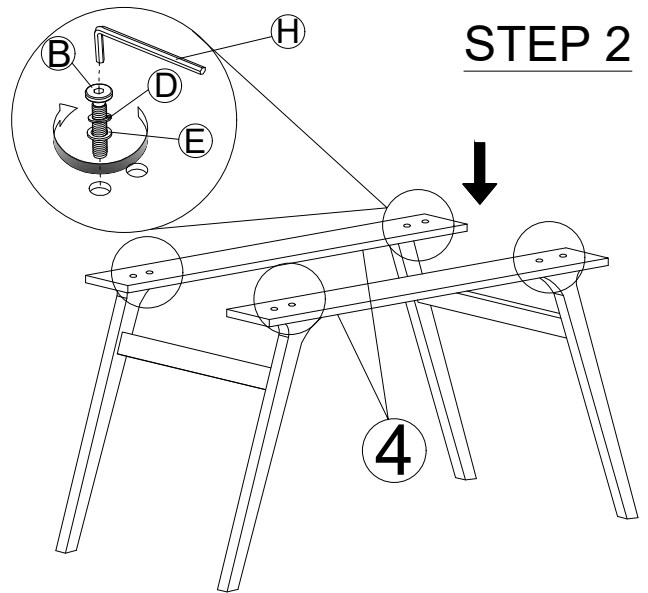

## STEP 3

