

INSTRUCTION MANUAL

FITTINGS

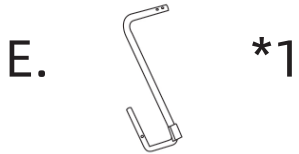

ASSEMBLY ICON

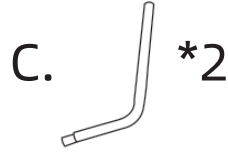
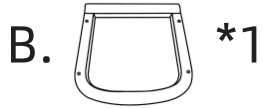
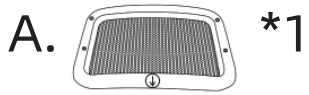
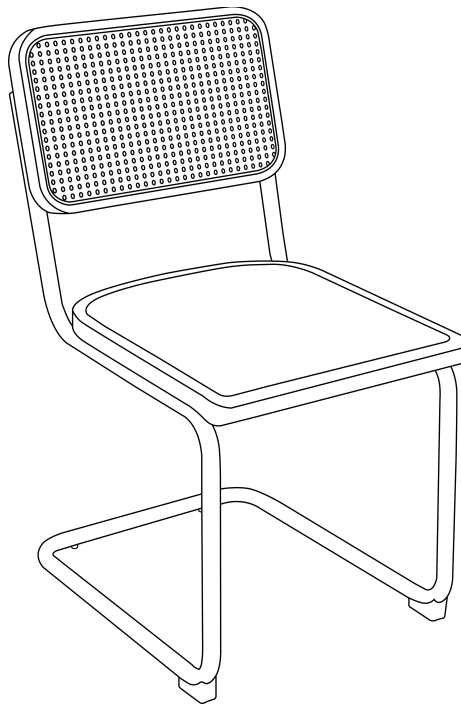

Tighten the product as shown in the figure above.

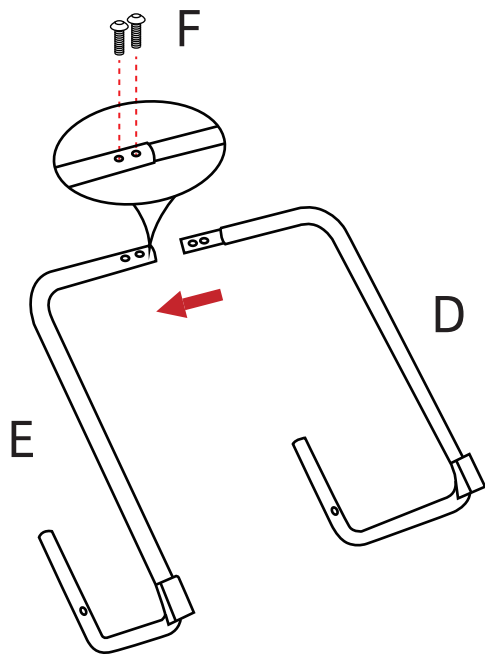

1、 Connect the two iron frames together and screw them into the circumference with (F) .
You can refer to the diagram on the right and rotate it to screw it in more easily.

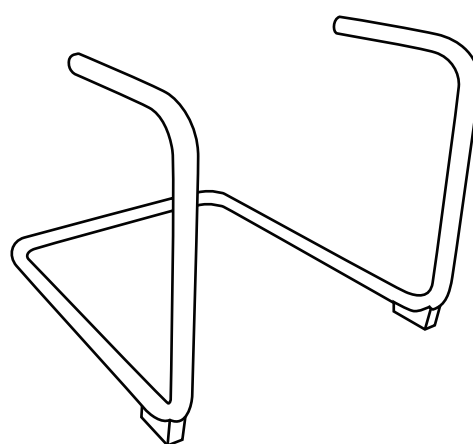
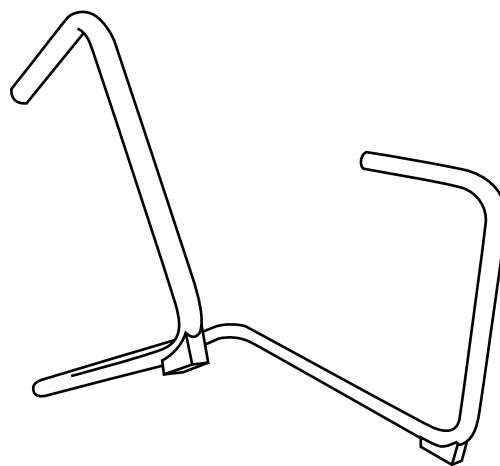
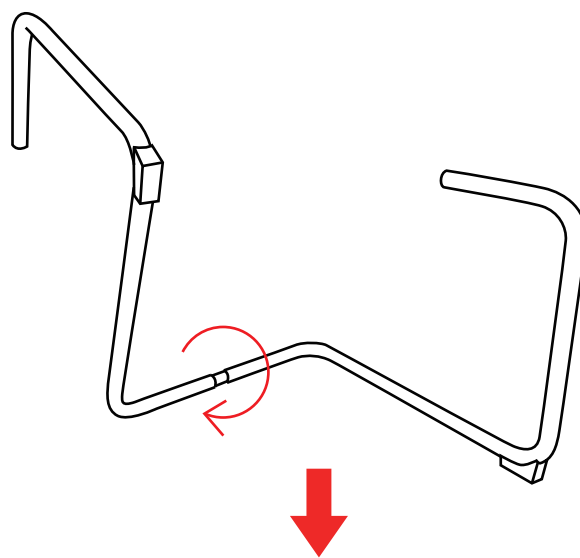

Firstly tighten all the screws 70%
when finished the assemble tighten all the screws 100%

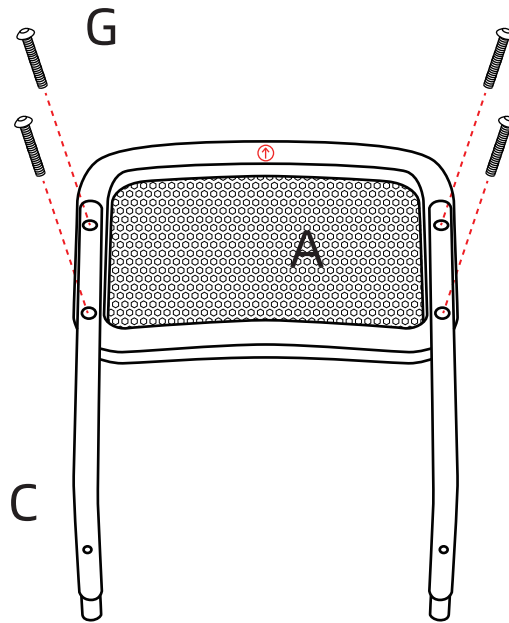

2、 Insert Screws (G) by Wrench (H) with Part A and Part C do not fully tighten at this stage.

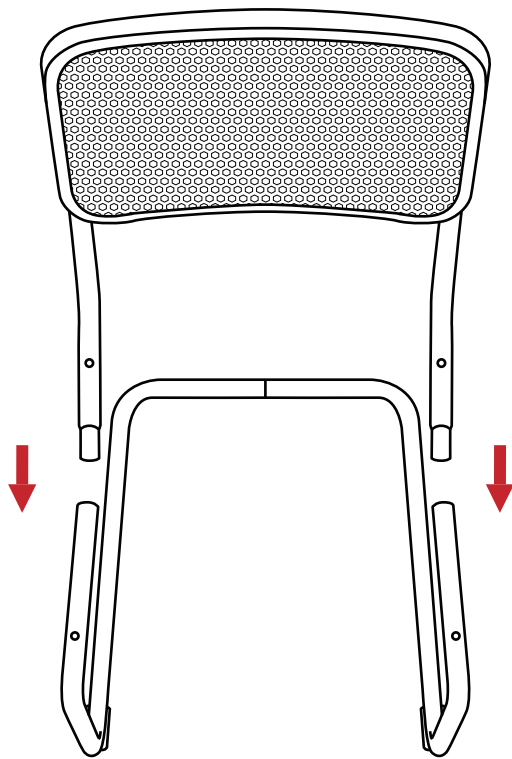

3、 Insert Part C into Part D,E.

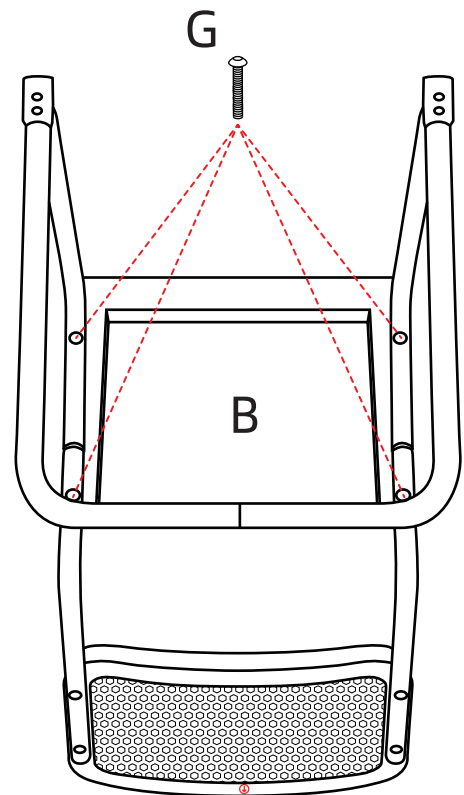

4、 Insert Screws (G) by Wrench (H) for Part B. and tighten screws to 100%.