

MODEL #

CM7479-Q

Questions?

GIVE US A CALL: 1-888-980-5122
MON – FRI 8:30AM – 5:30PM (PT)

ASSEMBLY INSTRUCTIONS

TOOLS REQUIRED



Allen Wrench

(Included)



Phillips
Screwdriver

(Not Included)

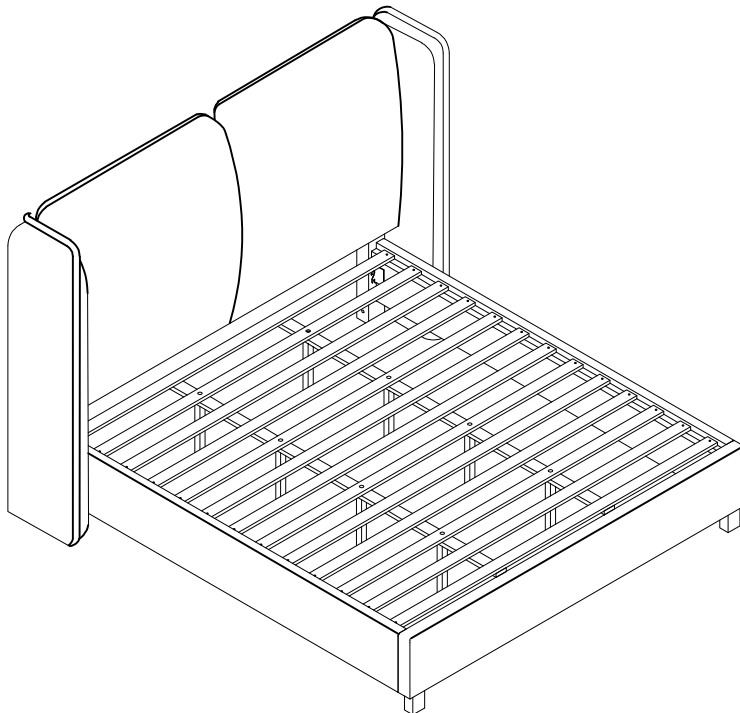

**2 - People
Recommended**

ASSEMBLY RATING



EASY → DIFFICULT

The Assembly Rating is a 5-point system showing the level of effort needed to assemble a specific product.





FOA Intro

Thank you for your purchase!

We hope you enjoy this new addition to your home for many years to come.

Our commitment to providing quality products does not simply end when you purchase our product. We fully stand behind our products from start to finish. Our customer service department is available Monday – Friday 8:30 AM – 5:30 PM Pacific Time and can help with assembly questions as well as, if necessary, replacing damaged or missing parts. To help expedite our service, please have these assembly instructions readily available, along with your order receipt.

 **Consumer Hotline**
Toll-Free 1-888-980-5122

 **Monday to Friday**
8:30AM- 5:30PM (PT)

 **WEBSITE**
www.foagroup.com

 **E-MAIL**
cs.ec@foagroup.com

    foagroup

 FurnitureOfAmerica

CHECK BEFORE STARTING

Are you missing anything?
Double-check all parts, hardware and accessories listed are all accounted for.

Check out our Quick Tips!
We recommend reviewing the pre-assembly handouts. Even experts need a refresher now and then!

Should we send any replacements?
Are there any irregularities or flaws in the parts? We can send replacements!

Prep Time!
Please review the assembly instructions and all diagrams prior to assembling.

PRE ASSEMBLY INTRODUCTION

We understand building ready-to-assemble furniture can be a challenging experience for some. To help avoid confusion, we have provided some helpful tips that may speed up the process.

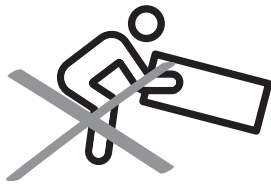

Teamwork

ALWAYS have at least two people to help with transporting and assembling the product to avoid potential injury and/or damage.

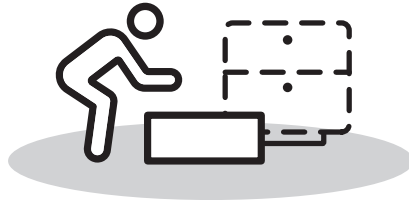
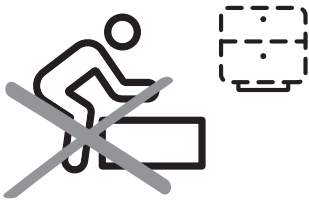

Suitable Location

Assembling near the area of the intended location is highly recommended.



Sufficient Space

Make sure you have enough space to move around during the assembly.

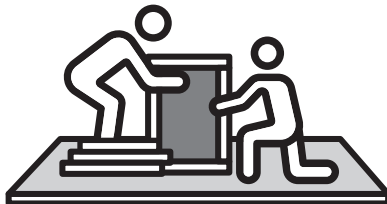

Avoid Scratches

Use cardboard, blankets or a carpeted area while assembling furniture to prevent to prevent scratches and damages.

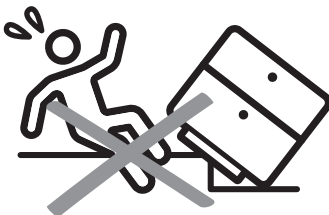

Flat Surface

Make sure the furniture rests on a flat and level surface with each leg evenly touching the floor.

ASSEMBLY AND CARE ADVICE



FAILURE TO FOLLOW THE GUIDELINES BELOW MAY RESULT IN INJURY AND/OR PROPERTY DAMAGE.



Position each part correctly and insert screws or bolts into their respective holes.



Use the appropriate hand tools or power tools for assembly. Select steps, such as tightening screws and/or bolts, may require hand tools to avoid causing damage during assembly.



Turn clockwise to tighten and only tighten when step is completed or when instructed to do so.



Save the instructions and store any supplied tools for later maintenance.



After two weeks, check and tighten any loose hardware and repeat again every six months thereafter.

IT IS THE USER'S RESPONSIBILITY TO MAINTAIN THE FURNITURE. THE HARDWARE MAY LOOSEN OVER TIME AND MAY CAUSE THE FURNITURE TO BE WOBBLY AND UNABLE TO SUPPORT ITS INTENDED WEIGHT CAPACITY. THIS MAY LEAD TO COLLAPSE AND MAY CAUSE SERIOUS INJURY.

BED

CM7479 - Q



- Please keep instructions for future reference.
- Check the quantity and irregularity of parts and hardware before you start.

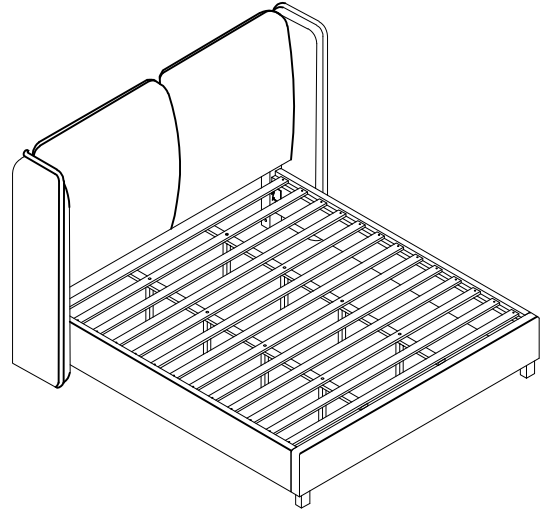

PARTS

#1 x 2pcs (L+R)



Headboard

#2 x 1pc



Footboard

#3 x 2pcs



Side Rail

#4 x 2pcs(L+R)



Wings

#5 x 2pcs(L+R)



HB LEG

#6 x 2pcs



FB LEG

#7 x 1set

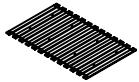

Slat (13pcs)

#8 x 8pcs



Support leg

#9 x 2pcs



Support Rail

HARDWARE

#A x 1pc



Allen Key

#B x 2pcs



Bolt Ø5/16"X 5"

#C x2pcs



Bolt Ø5/16"X 3"

#D x11pcs



Bolt Ø5/16"X 2"

#E x8pcs



Bolt Ø5/16"X 1-1/2"

#F x 10pcs



Flat Washer Ø5/16"X19MM

#G x 13pcs



Flat Washer Ø5/16"X22MM

#H x 23pcs



Spring Washer

#I x 26pcs







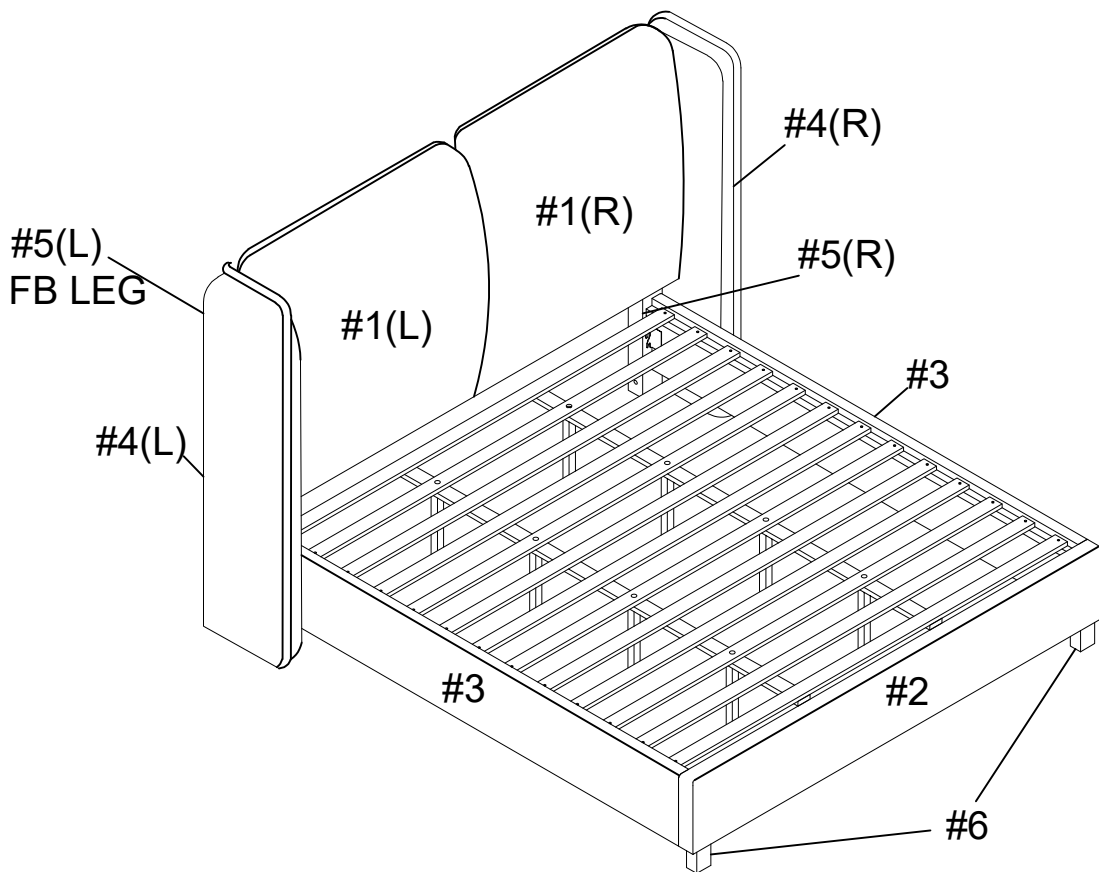
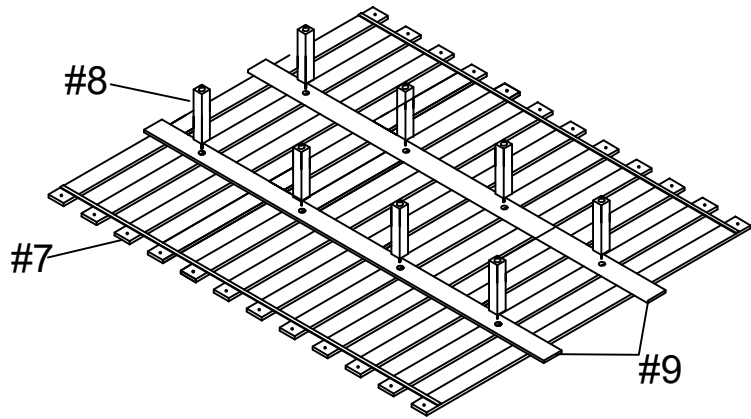

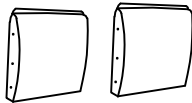
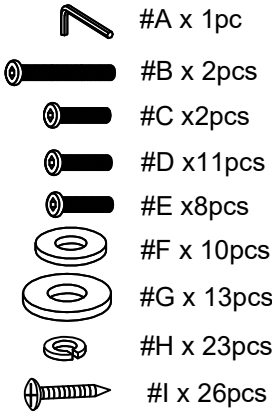

Screw M4X38MM

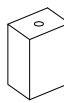
Exploded View

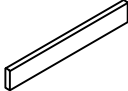

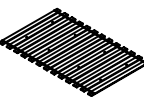
CM7479 Q is packed in 3 cases

Carton	Disignation	Part	Hardware
CM7479Q-1	Headboard (L+R)	#1 	
	HB LEG (L+R)	#5  x 2	
	FB LEG	#6  x 2	
	Support leg	#8  x 8	
CM7479Q-2	Footboard	#2 	
	Side Rail	#3 	
	Slat (13pcs)	#7 	
	Support Rail	#9  x 2	
CM7479Q-3	Wings (L+R)	#4 	

ASSEMBLY INSTRUCTIONS

Remove parts from the hidden compartment behind the headboard. Lift Velcro and align the Right and Left Headboard (#1) and secure by using Bolt (#D) With Spring Washer (#H) and Flat Washer (#G).

1

- Part #1 x2pcs
- Hardware #A x1pc
- Hardware #D x3pcs
- Hardware #H x3pcs
- Hardware #G x3pcs

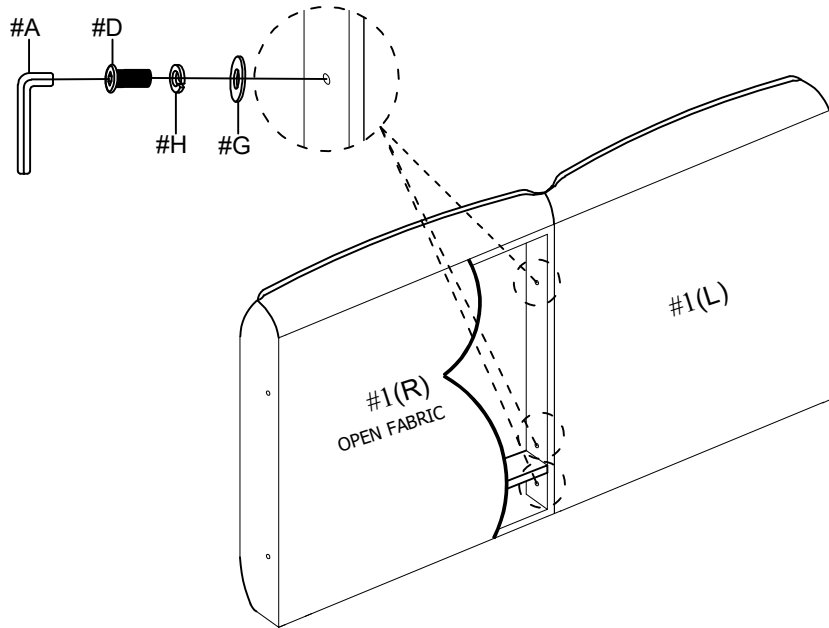

2

- Part #5 x2pcs
- Hardware #A x1pc
- Hardware #D x4pcs
- Hardware #H x4pcs
- Hardware #G x4pcs

Align and attach the HB Leg (#5) to the Headboard (#1) and secure by using Bolts (#D) with Spring Washer (#H) and Flat washer (#G).

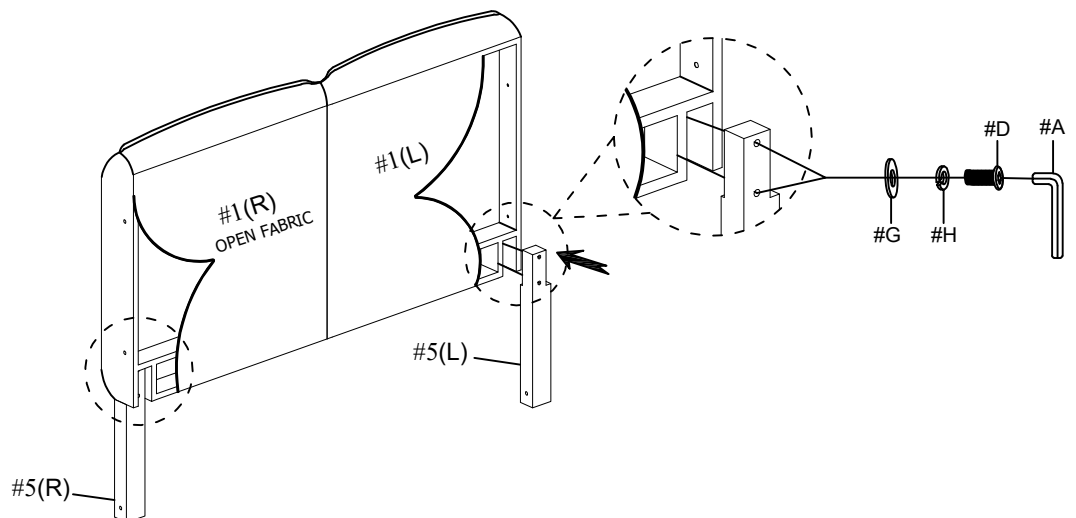

ASSEMBLY INSTRUCTIONS

3

- Part #4 x2pcs
- Hardware #A x1pc
- Hardware #B x2pcs
- Hardware #D x4pcs
- Hardware #H x6pcs
- Hardware #G x6pcs

Align the Left/Right Wing (#4) to the Headboard (#1) and secure by using Bolt (#D) with Spring Washer (#H) and Flat washer (#G). Attach the Wing (#4) to the HB Leg (#5) by using Bolt (#B) and Spring Washer (#H) and Flat washer (#G).

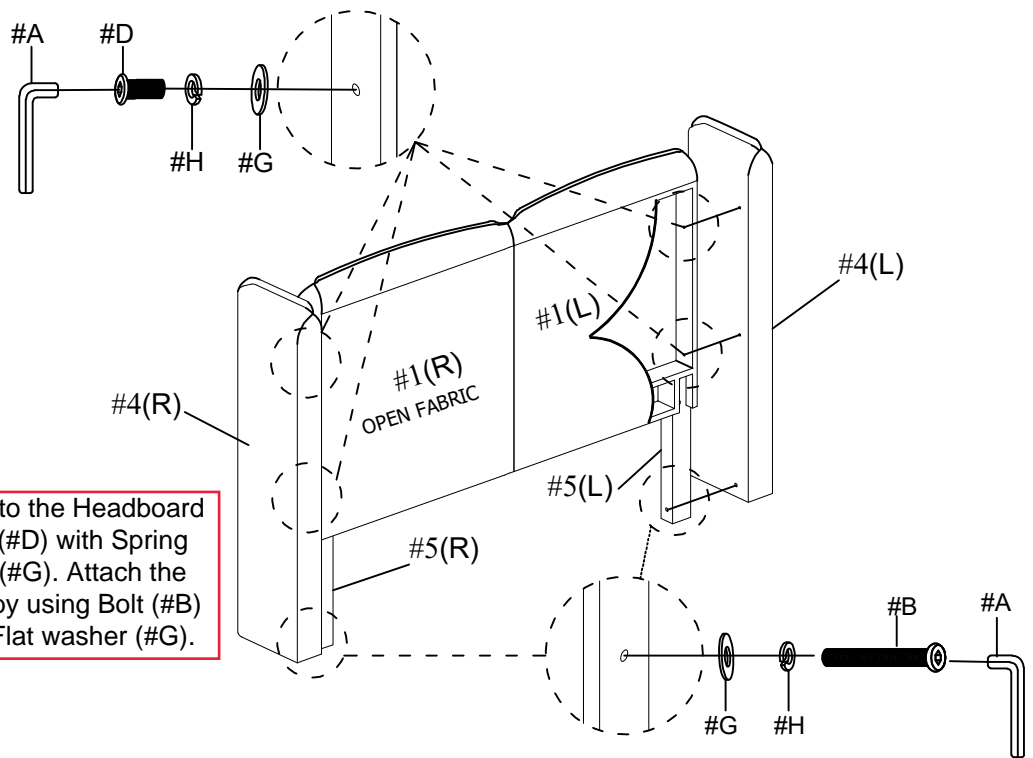

4

- Part #2 x1pc
- Part #6 x2pcs
- Hardware #A x1pc
- Hardware #C x2pcs
- Hardware #F x2pcs
- Hardware #H x2pcs

Attach the FB Leg (#6) to the Footboard (#2) and secure using Bolt (#C) with Spring Washer (#H) and Flat Washer (#F).

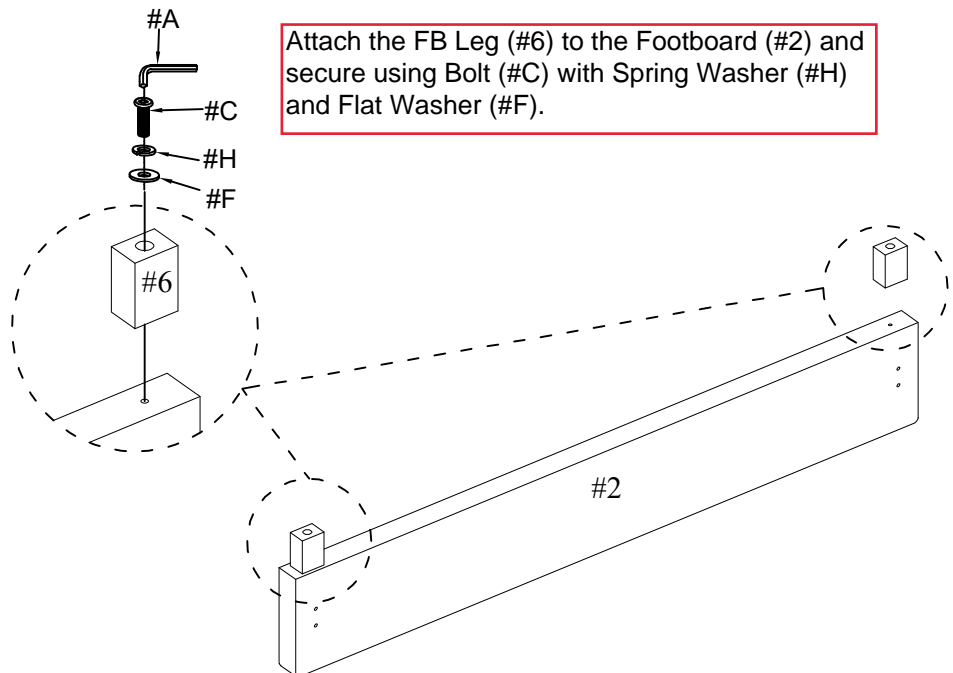

ASSEMBLY INSTRUCTIONS

Insert Bolt (#E) with Spring washer (#H) and Lock washer (#F) to the HB Leg (#5) and Footboard (#2). Hook the rail (#3) onto the bolt and tighten to secure in place.

5

- Part #3 x2pcs
- Hardware #A x1pc
- Hardware #E x8pcs
- Hardware #F x8pcs
- Hardware #H x8pcs

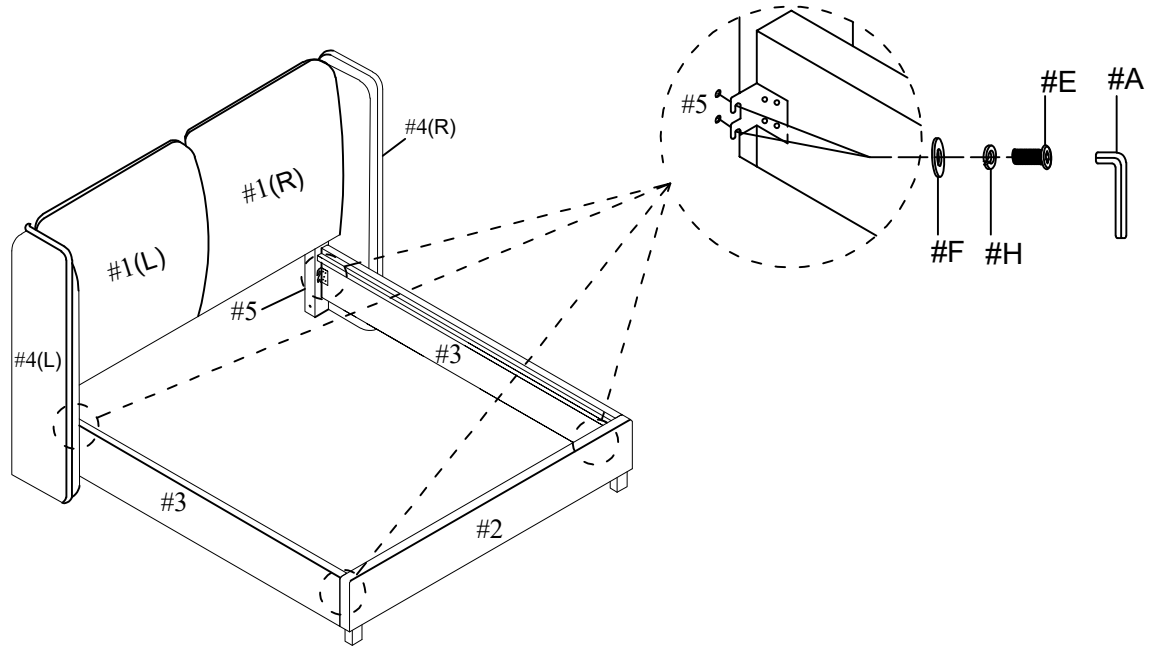

6

- Part #7 x1Sets
- Part #8 x8pcs
- Part #9 x2pcs

Align the Support rails (#9) onto the slats. Twist the Support legs (#8) the slat (#7) to secure.

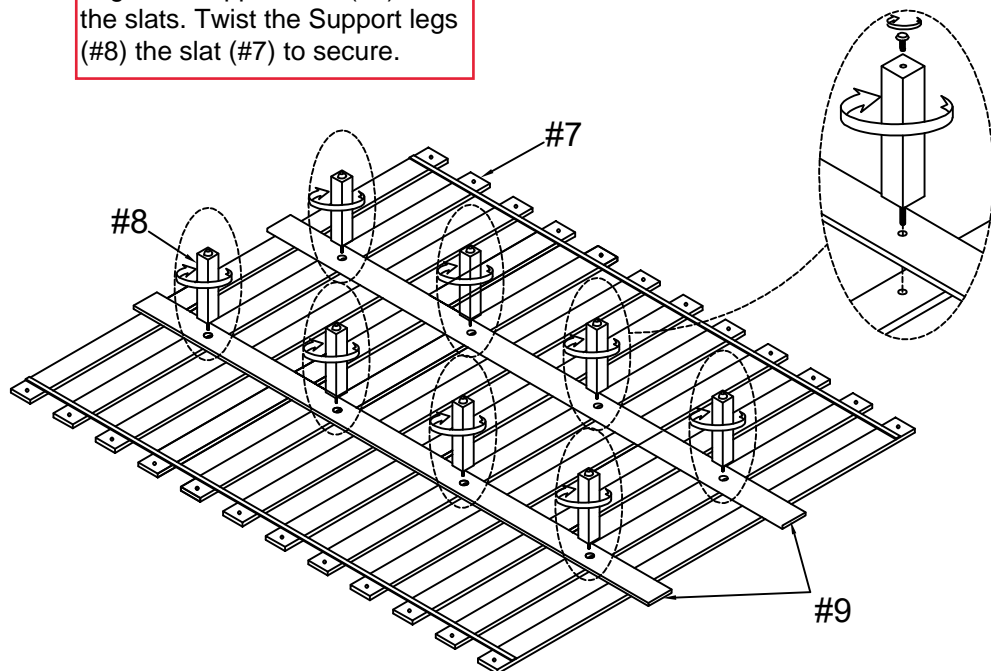

ASSEMBLY INSTRUCTIONS

7

Align the slats (#13) evenly onto the Rails (#3) and secure using Screw (#1).

Hardware  x26pcs

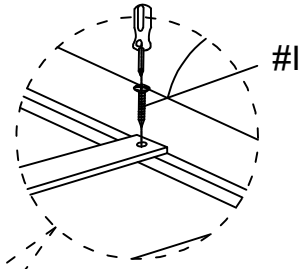
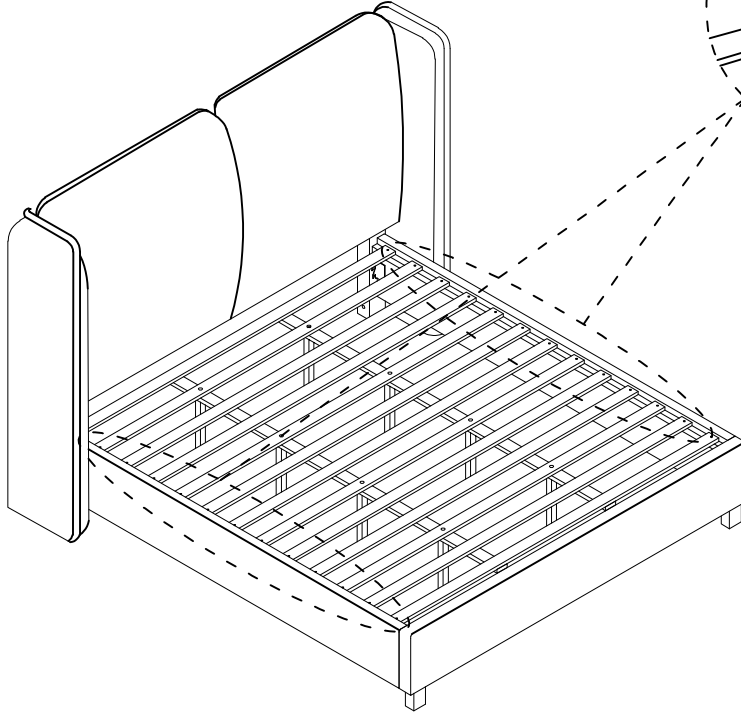

8

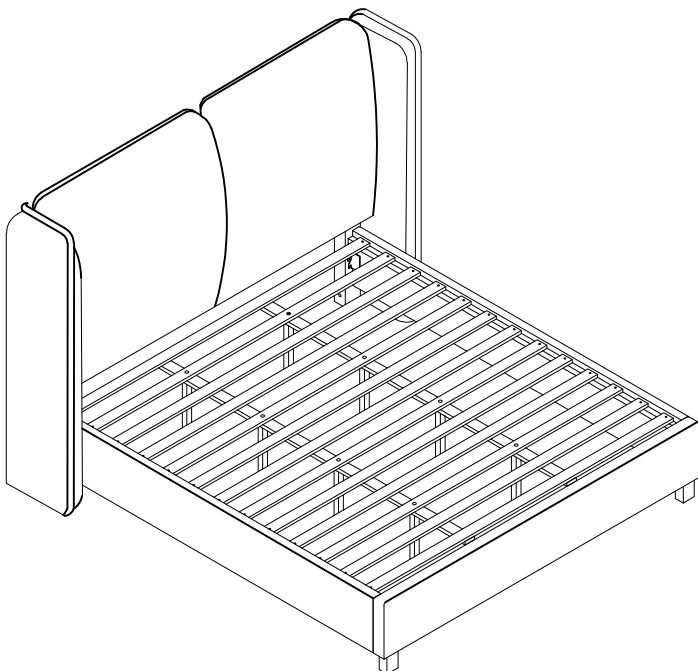

ASSEMBLY COMPLETED



Please ensure the furniture rests on an even and flat surface. If the product wobbles or feels loose, double-check all bolts and/or screws are properly tightened and secured.



Keep this handy!

Please retain this instruction manual and any order-related information for future reference.



Lift, don't drag!

To avoid damage to product please always LIFT the product when transporting or adjusting the placement.