

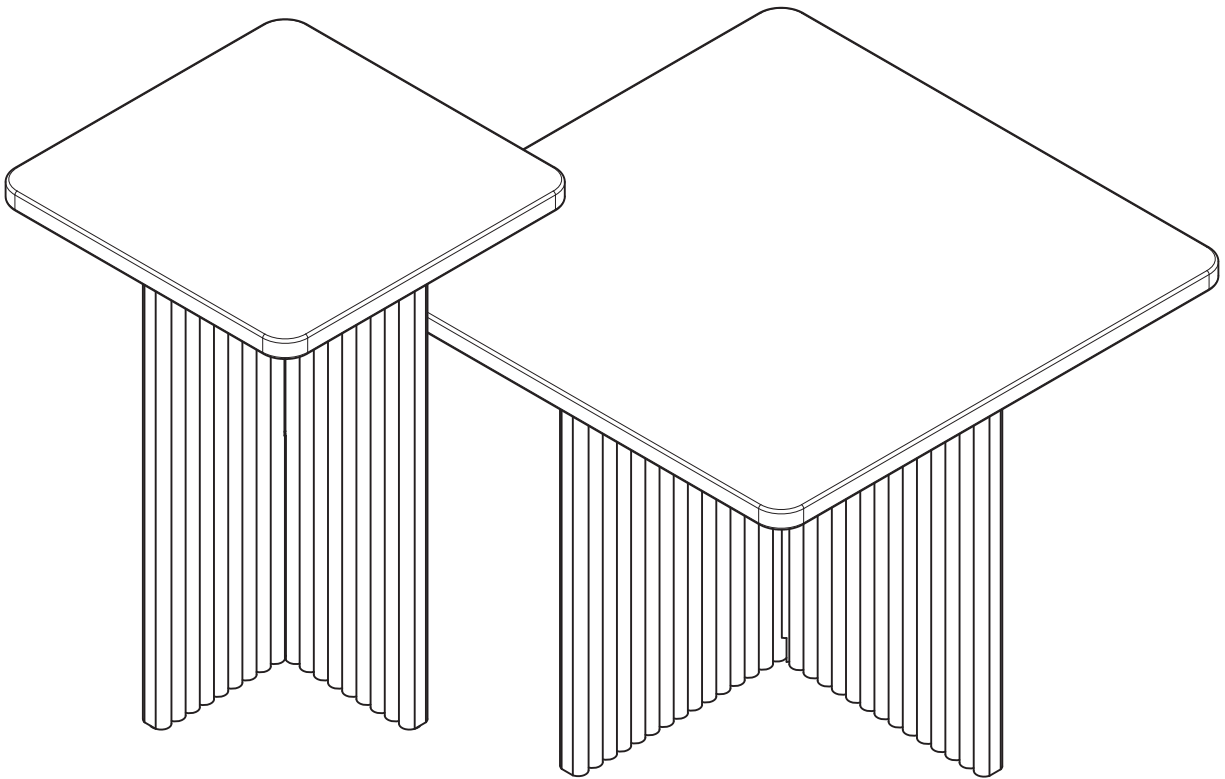







# **Square Fluted Nesting Coffee Table Set**

Assembly Instructions



Hardware Pieces		Quantity	Your Parts		Quantity	
1		Metal Plates	2	A	Large Table Top	1
2		Screws	16	B	Short Upper Leg	1
3		Hex Bolts	8	C	Short Lower Leg	1
4		Spring Washers	8	D	Small Table Top	1
5		Flat Washers	8	E	Tall Upper Leg	1
6		Allen Key	1	F	Tall Lower Leg	1

### What You'll Need

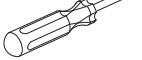
- Phillips screwdriver 
- A blanket or a flattened box to protect your piece during assembly

### Before Assembling, Remember!

- Make sure all hardware and pieces are accounted for before discarding the box.
- Pay close attention to all holes on each panel during assembly.
- Do not overtighten screws, as this may cause splitting.
- Use hand tools when assembling.
- No power tools allowed!

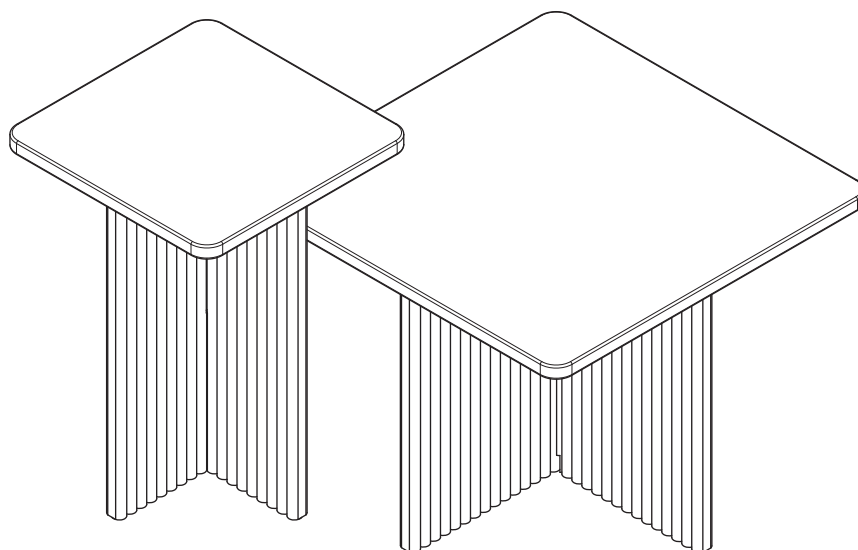

 Ready in  
as little as  
**30 min**

# Let's Build the Short Table!

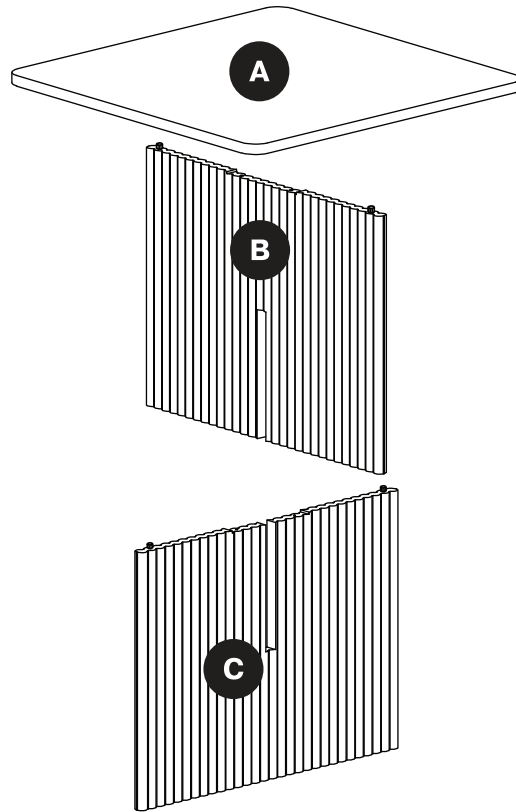

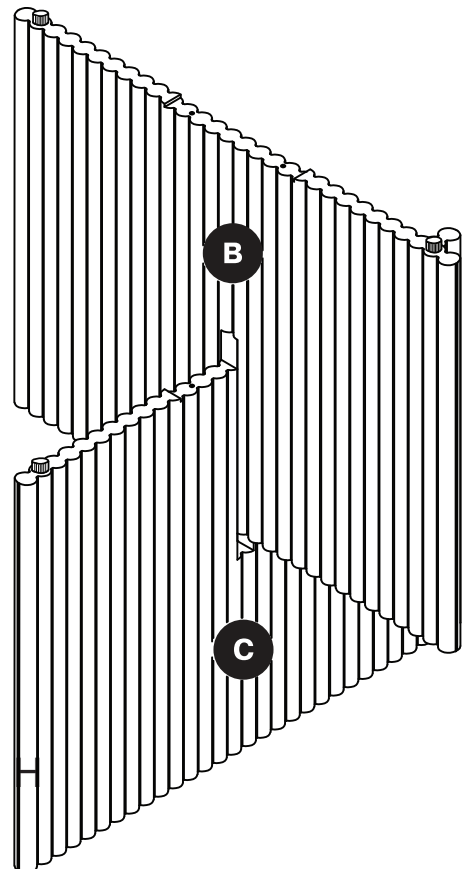

## Step 1

Align the slots on the Upper and Lower Legs (B&C) and slide them together.



## Step 2



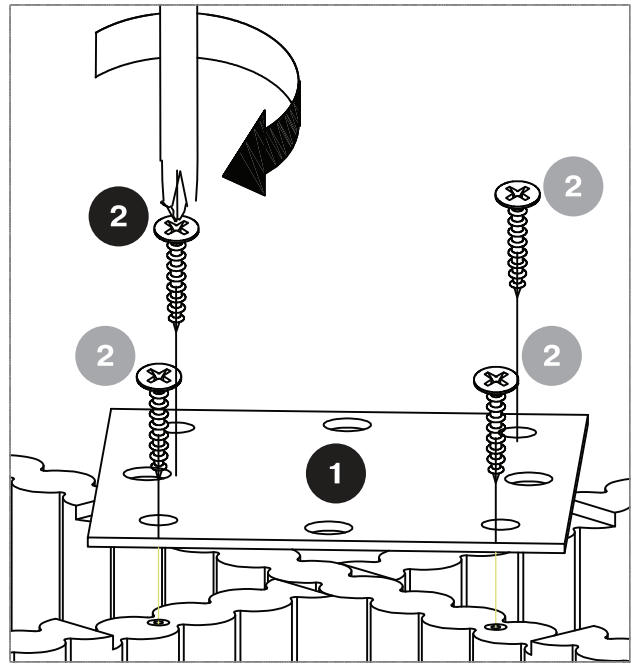
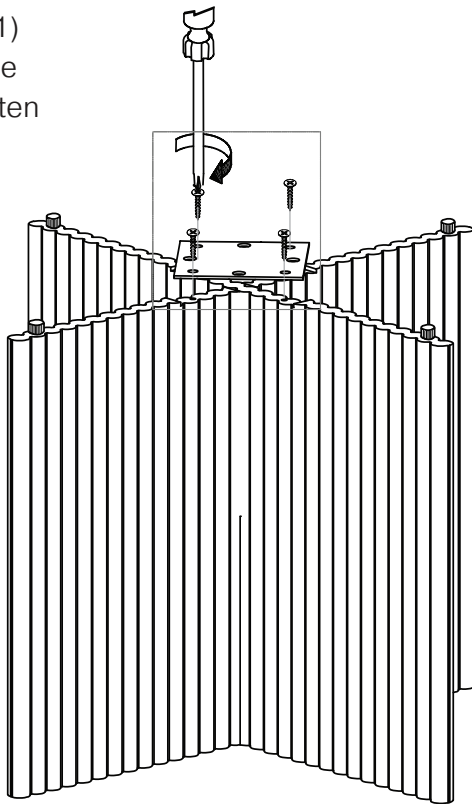

Line up the Metal Plate (1) with the holes on the table legs, then insert and tighten Screws (2).

- 1**  Metal Plate x 1
- 2**  Screw x 4



## Step 3

Place your Table Top (A) upside down on a blanket or box. Put the legs on top (with the rubber feet facing up) and line up the holes and wooden dowels. Put a Spring Washer (4) and then a Flat Washer (5) on each Hex Bolt (3), and use your Allen Key (6) to tighten the bolts.

- 3**  Hex Bolt x 4
- 4**  Spring Washer x 4
- 5**  Flat Washer x 4
- 6**  Allen Key x 1

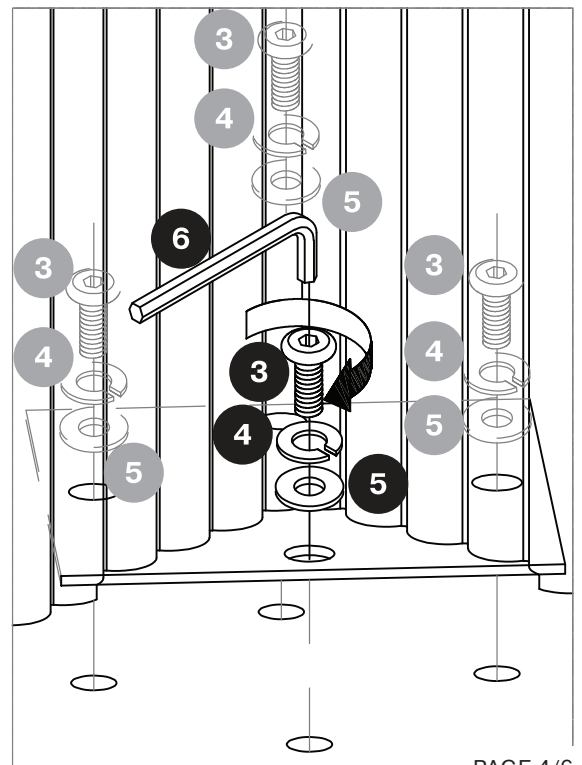
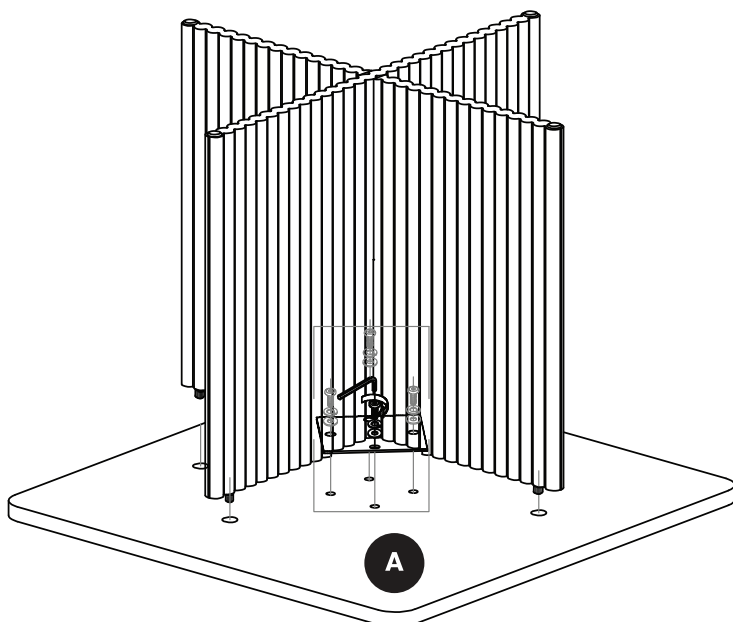

# Short Table Finished

Carefully flip the table over.

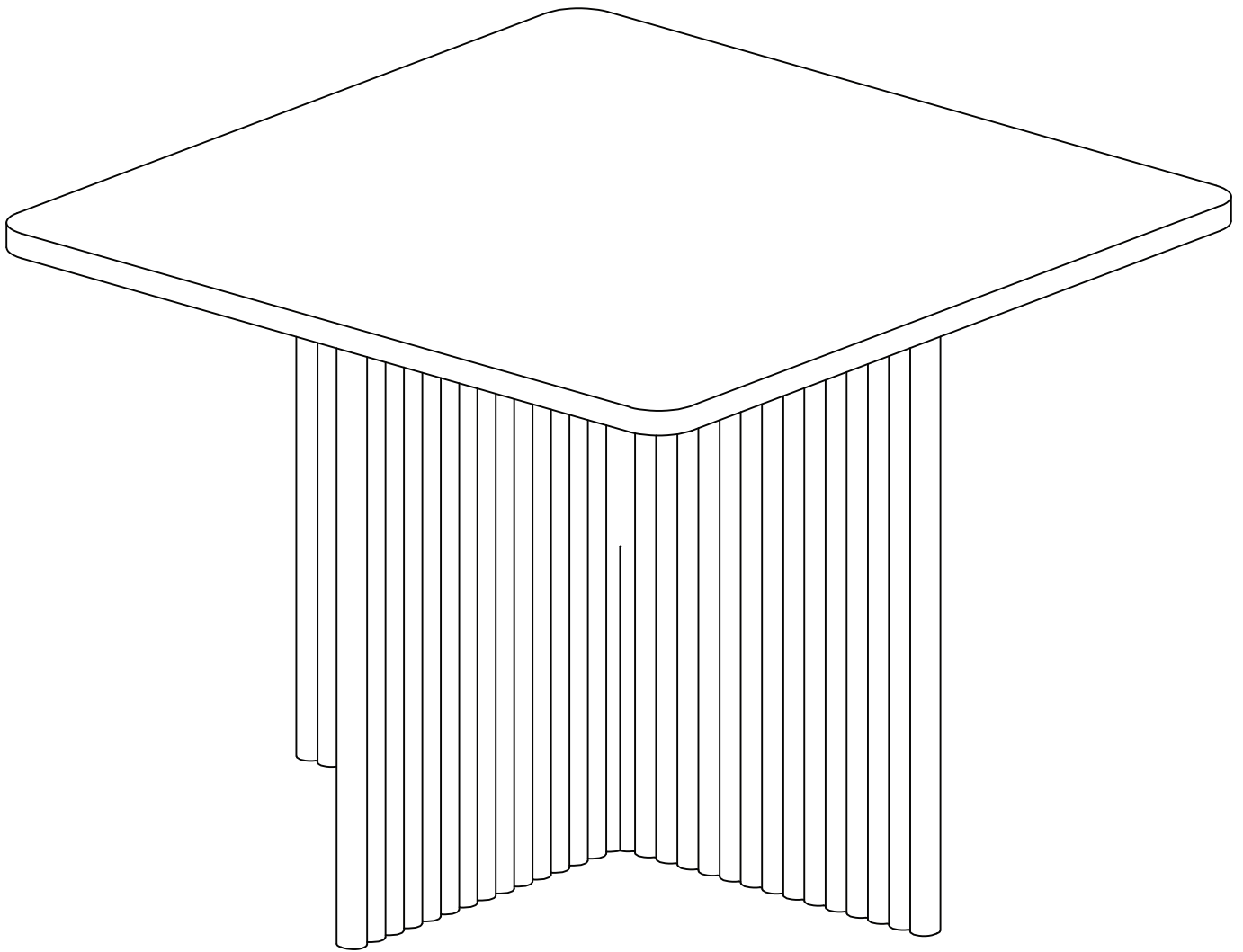

# Now Let's Build the Tall Table!

## Step 4

Gather the remaining wood pieces together.

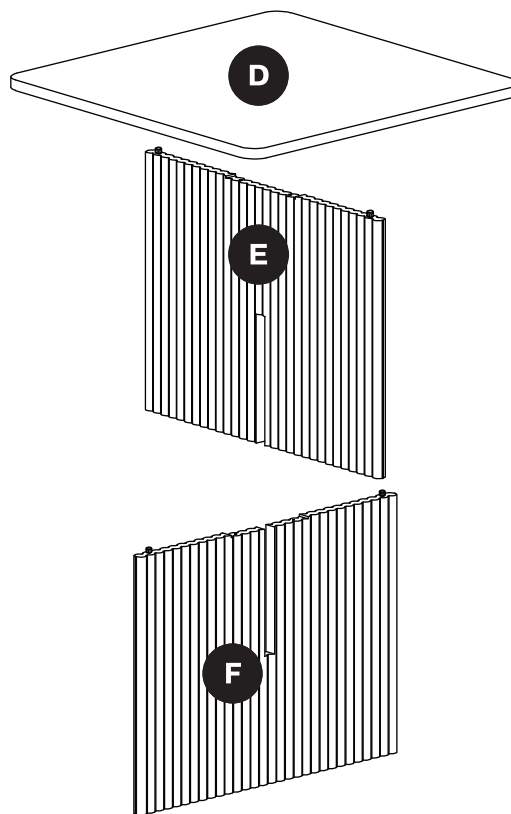

## Step 5

Align the slots on the Tall Upper and Lower Legs (E&F) and slide them together.

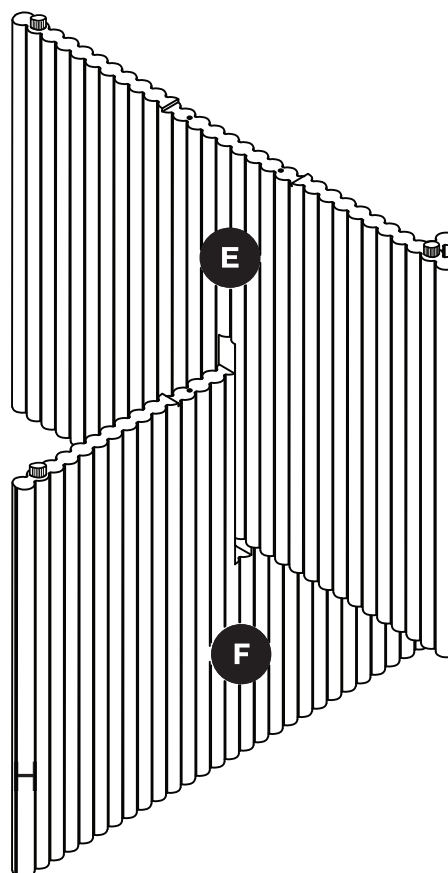

## Step 6



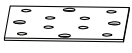
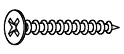

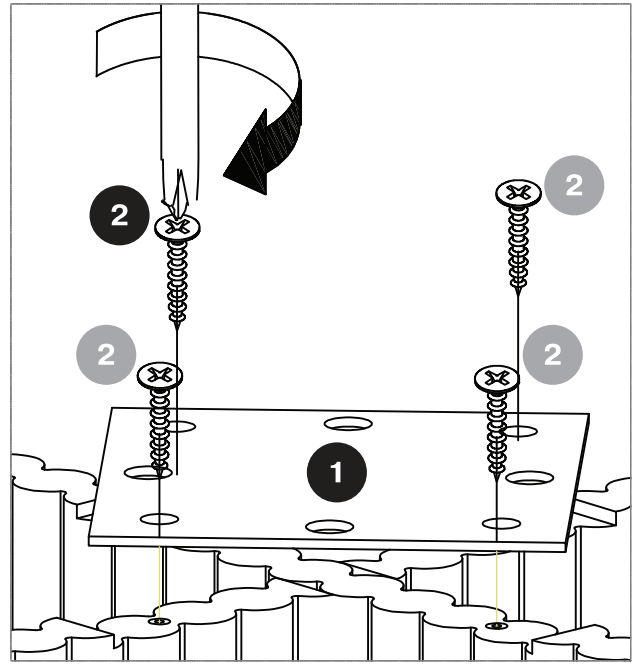
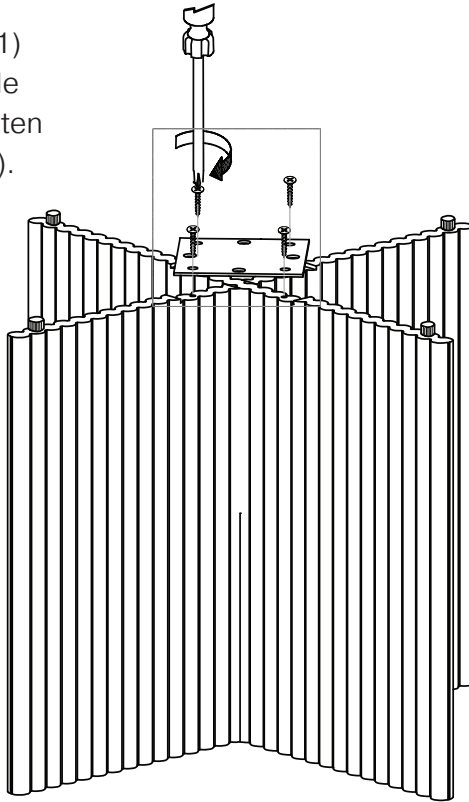
Line up the Metal Plate (1) with the holes on the table legs, then insert and tighten the remaining Screws (2).

- 1**  Metal Plate x 1
- 2**  Screw x 8



## Step 7

Place your Small Tabletop (D) upside down on a blanket or box. Put the legs on top (with the rubber feet facing up) and line up the holes. Put a Spring Washer (4) and then a Flat Washer (5) on each Hex Bolt (3), and use your Allen Key (6) to tighten the bolts.

- 3**  Hex Bolt x 4
- 4**  Spring Washer x 4
- 5**  Flat Washer x 4
- 6**  Allen Key x 1

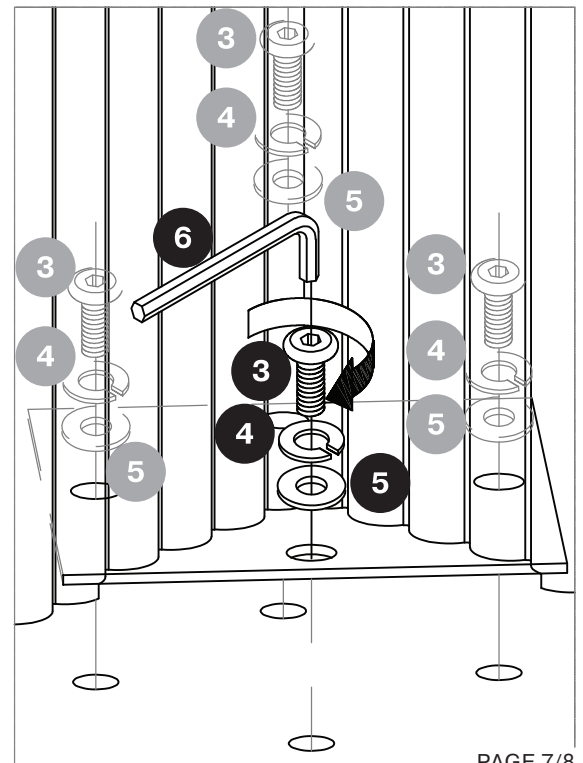
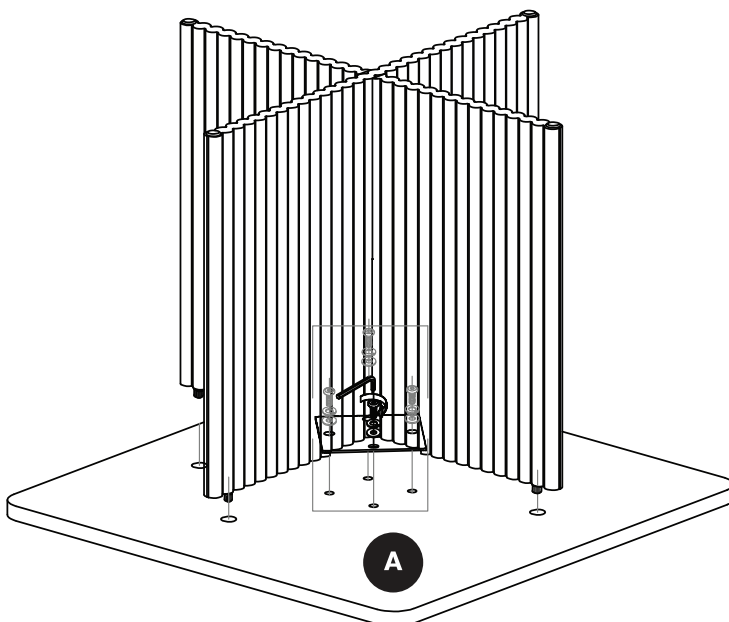

## Tall Table Finished

Carefully flip the table over.

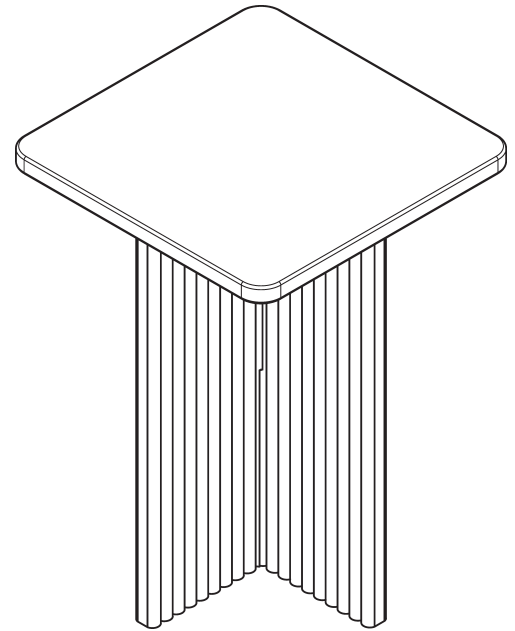

## Nesting Set Finished

Pat yourself on the back! You've earned it and a set of 2 brand-new tables!  
Arrange them together or separately.

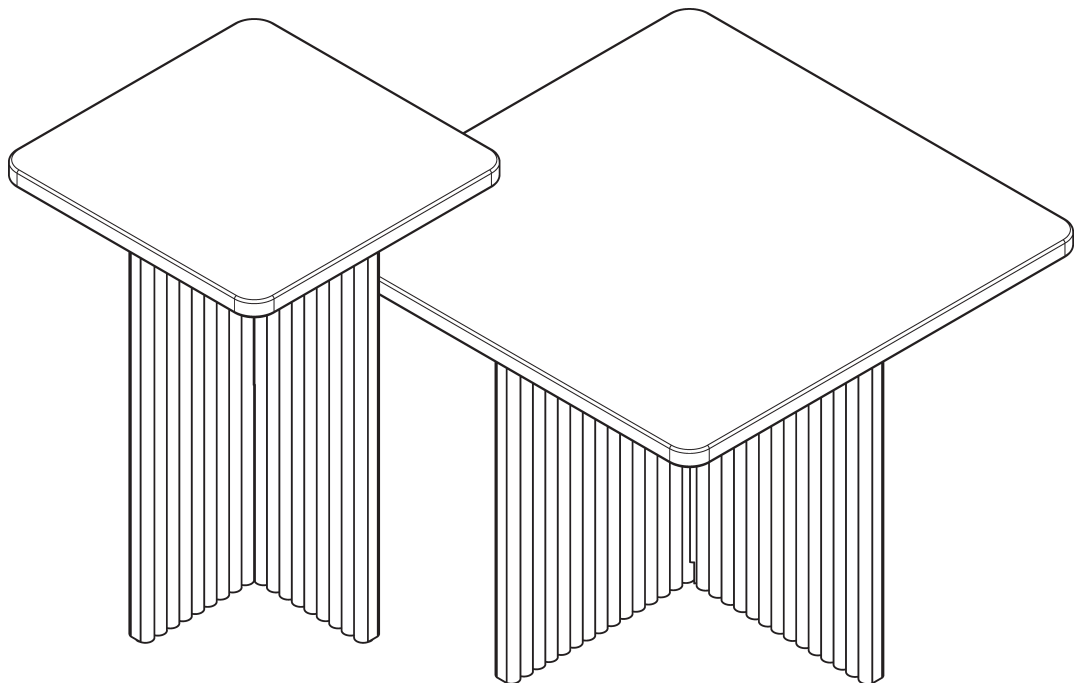

To see more of our unique products,  
visit our website at [steadfurniture.com](https://steadfurniture.com)  
**Questions?** Contact [support@steadfurniture.com](mailto:support@steadfurniture.com)