

**STEP 7**

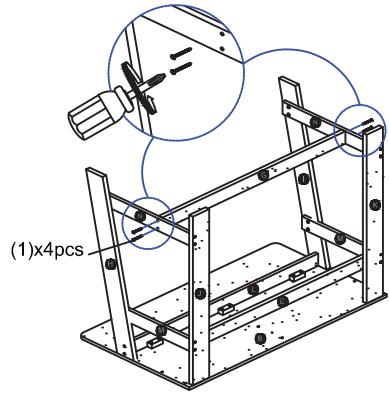

**STEP 8**

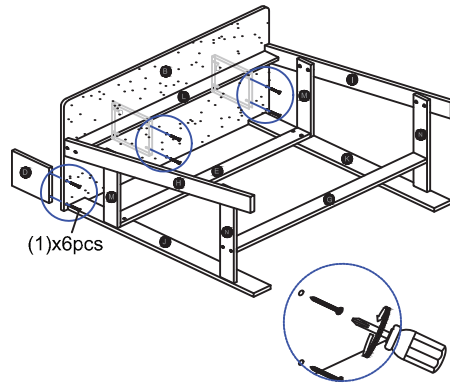

**STEP 9**

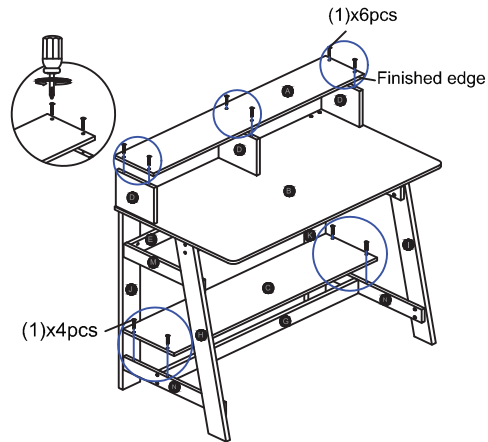

**STEP 10**

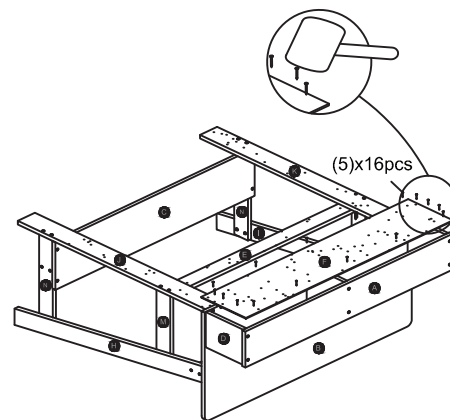

**Recommended Maximum Weight**

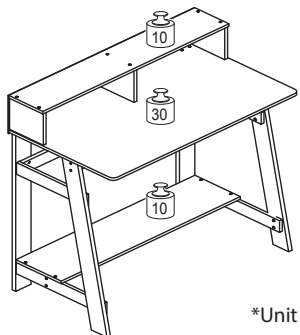

\*Unit in Pound(lbs)

**WARNING:**

>This unit has been designed to support the maximum loads shown. Exceeding these load limits could cause sagging, instability, product collapse, and/or serious injury.

>DO NOT allow children to climb on unit.

>Put heavier items on lower shelves.

00:30

Approx. 30 minutes



Recomm. 2 Person

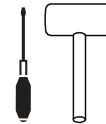

Tool Required

**Assembly Instruction**

"A" Frame Computer Desk

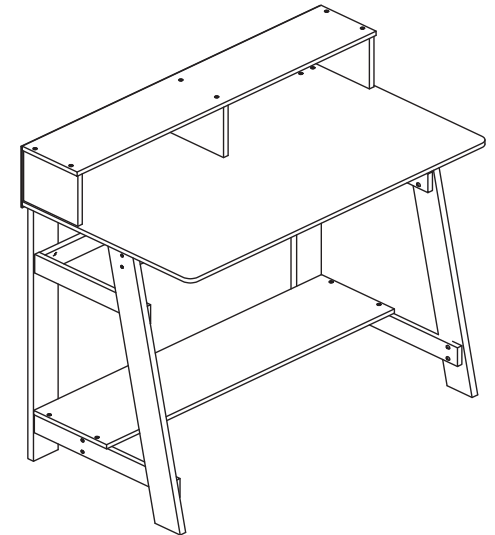

No	Hardware List	Qty
1	M4x38mm Chipboard Screw	36pcs
2	Tapping Screw	12pcs
3	45mm Bracket	3pcs
4	M4 x 25mm Chipboard Screw	6pcs
5	Power Pin	16pcs

No	Parts List	Qty
A	Upper Top Panel	1pc
B	Top Panel	1pc
C	Bottom Panel	1pc
D	Upper Side Panel	3pcs
E	Bottom Back Support Panel	1pc
F	Upper Back Panel	1pc
G	Leg Support Panel	1pc
H	Bottom Left Side Panel	1pc
I	Bottom Right Side Panel	1pc
J	Bottom Left Back Panel	1pc
K	Bottom Right Back Panel	1pc
L	Bottom Front Support Panel	1pc
M	Center Side Support Panel	2pcs
N	Bottom Side Support Panel	2pcs

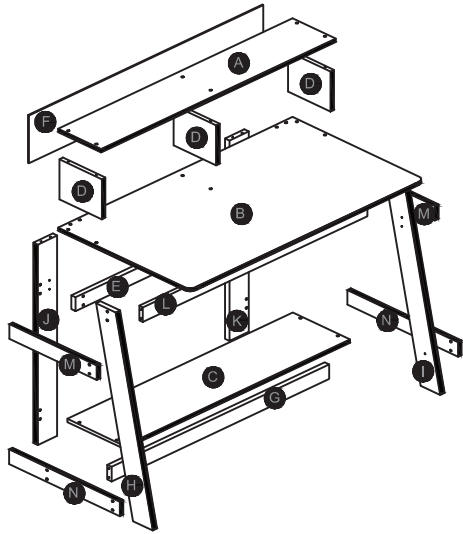

**USEFUL HINTS BEFORE YOU START:**

1. Read each step carefully before starting.
2. It is important that each step is performed in correct order to avoid difficulties.
3. Identify, sort and count the parts before assembly.
4. Assemble your furniture on packaging cardboard to prevent scratch or damage.
5. Clean the product with mild cleanser using soft damped cloth. Do not use harsh or abrasive cleanser.
6. Using incompatible hardware might cause damage to product.

**STEP 1**

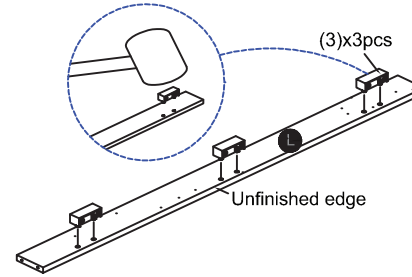

**STEP 2**

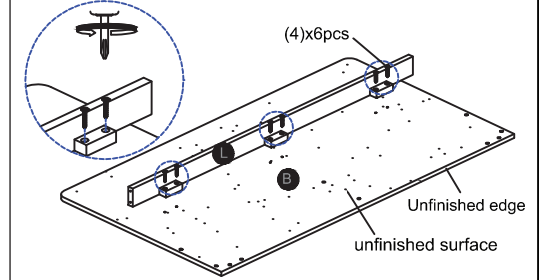

**STEP 3**

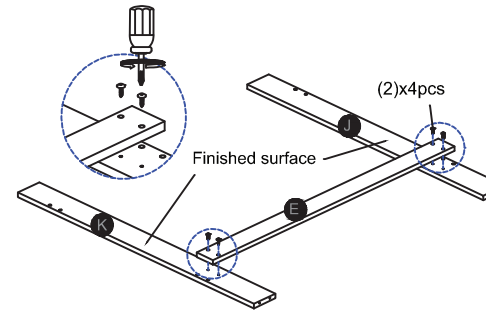

**STEP 4**

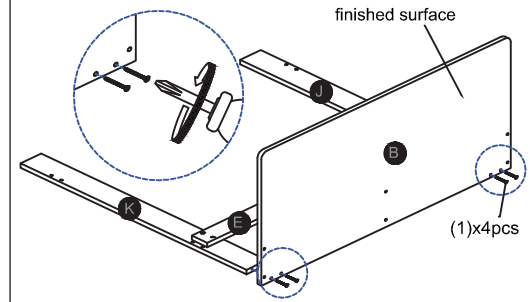

**STEP 5**

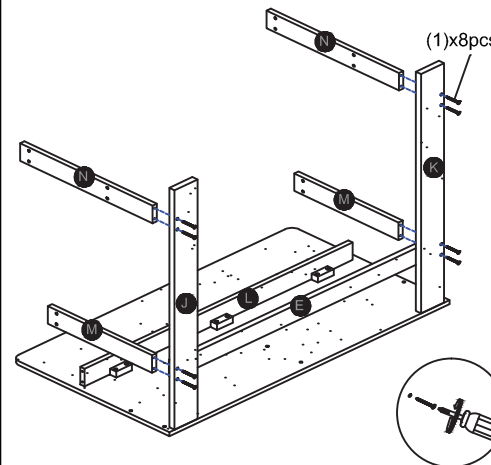

**STEP 6**

