

NOTICE

- * Please make sure that you have all parts indicated and they are in good condition before you begin assembly of this item. Refer to part list and hardware list below for guidance.
- * This item should be assembled on a soft surface to prevent scratching the finish during assembly.
- * This item may require periodic tightening.
- * If you are having difficulty, our friendly Customer Care team is always here to help.











PREPARATION

- * Before beginning assembly of product, make sure all parts are present. Compare parts with part contents list and hardware contents list.
- * If any part is missing or damaged, do not attempt to assemble the product.
- * Estimated Assembly Time: **30 minutes**.
- * Tools Required for Assembly (included): **Allen Key**

CARE AND MAINTENANCE

Store outdoor furniture indoors or cover well when not in use. Remove wooden furniture from standing water. Dust regularly with small brush or vacuum. Spills should be taken care of immediately before they harden or stain with a slightly dampened sponge. Do not use bleach solutions

Part List and Hardware List

PIECE	DESCRIPTION	PICTURE	QUANTITY
A	Glass Top		1X
B	Table Top Frame		1X
C	Seat Bench Frame		1X
D	Table Leg		4X
G	Bench Leg		8X
CSH1	Back Cushion		2X
CSH2	Seat Cushion		1X
HW1	Allen Bolt: M6 x 0.5 x 20 mm		32X
HW2	Flat Washer: M6 x 1 mm		32X
HW3	Allen Key		1X

Owner Manual

Product Dimensions

43.31"W x 21.65"D x 15.75"H (Table)

51.97"W x 28.35"D x 26.38"H (Bench 2S)

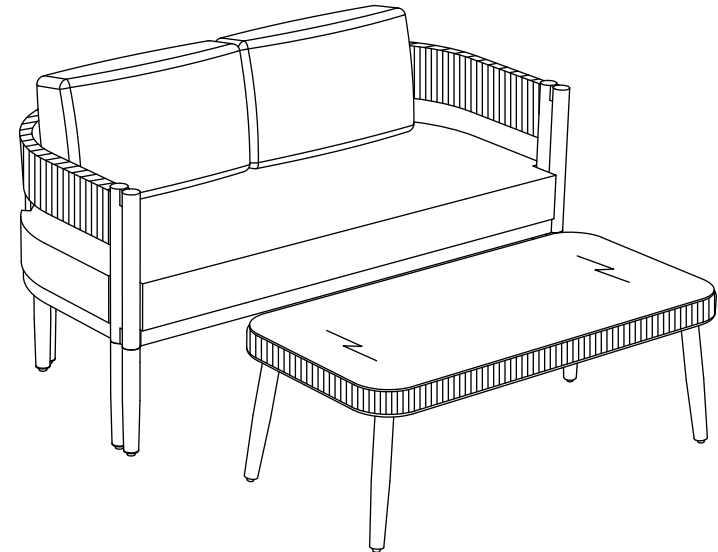

Weight Capacity : 176 lbs (Table)

: 704 lbs (Bench 2S)

Warning : Do not stand on Table/Bench

Warning : Do not over torque bolts/screws

PREPARATION

- * Before beginning assembly of product, make sure all parts are present. Compare parts with part contents list and hardware contents list.
- * If any part is missing or damaged, do not attempt to assemble the product.
- * Estimated Assembly Time: **30 minutes**.
- * Tools Required for Assembly (included): **Allen Key**

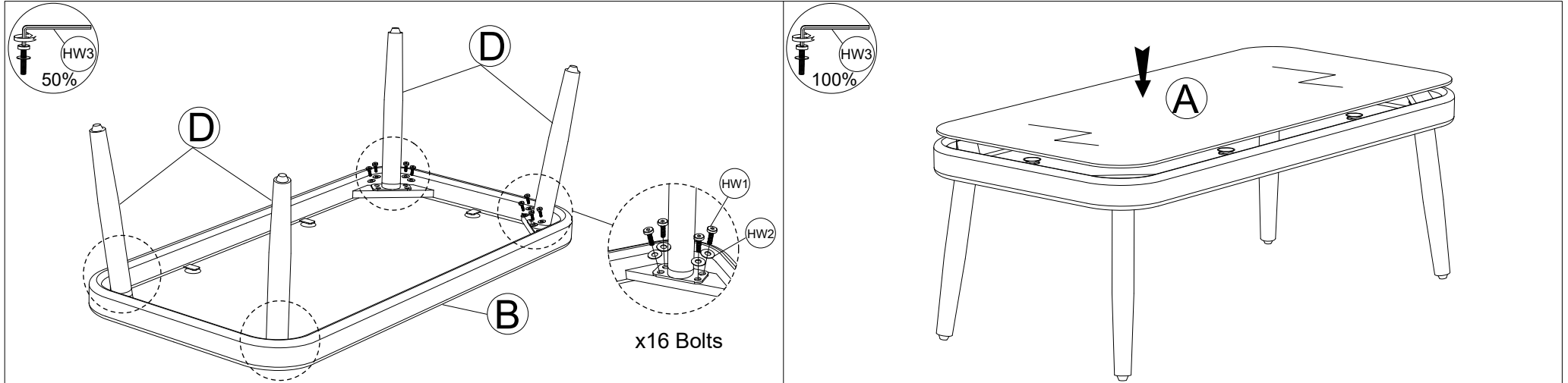

STEP 1: Connect Table Top Frame (B) & Table Leg (D), tighten Bolt (HW1), Flat Washer (HW2) with Allen Key (HW3).

STEP 2: Firmly tighten all the Bolts with Allen Key (HW3). Put the Table upright & put the Glass (A) on Table.

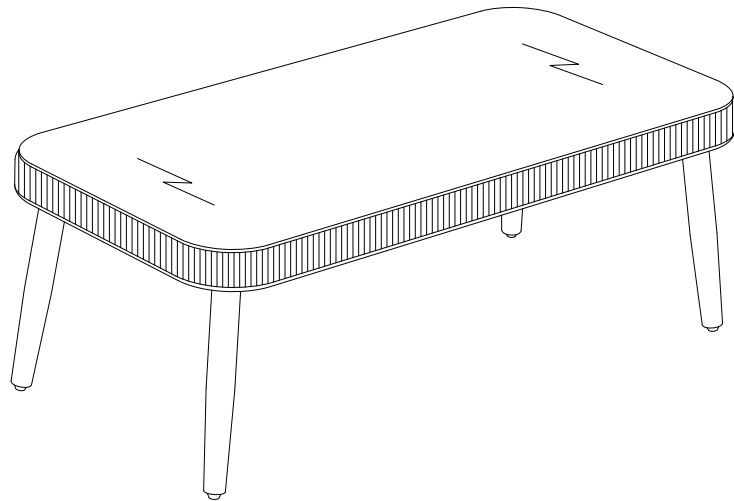

Finish Table

PREPARATION

- * Before beginning assembly of product, make sure all parts are present. Compare parts with part contents list and hardware contents list.
- * If any part is missing or damaged, do not attempt to assemble the product.
- * Estimated Assembly Time: **30 minutes.**
- * Tools Required for Assembly (included): **Allen Key**

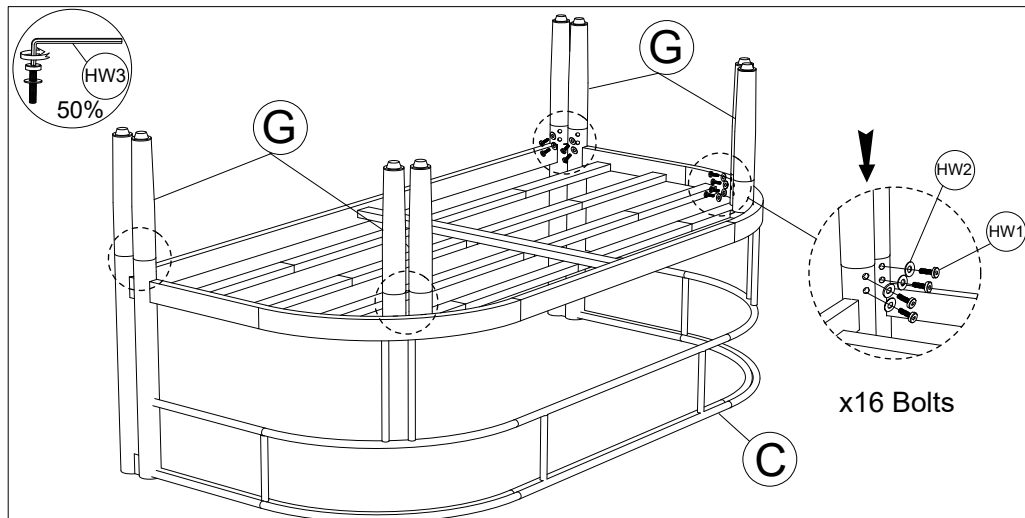

STEP 3: Connect Seat Bench Frame (C) & Bench Leg (G), tighten Bolt (HW1), Flat Washer (HW2) with Allen Key (HW3).

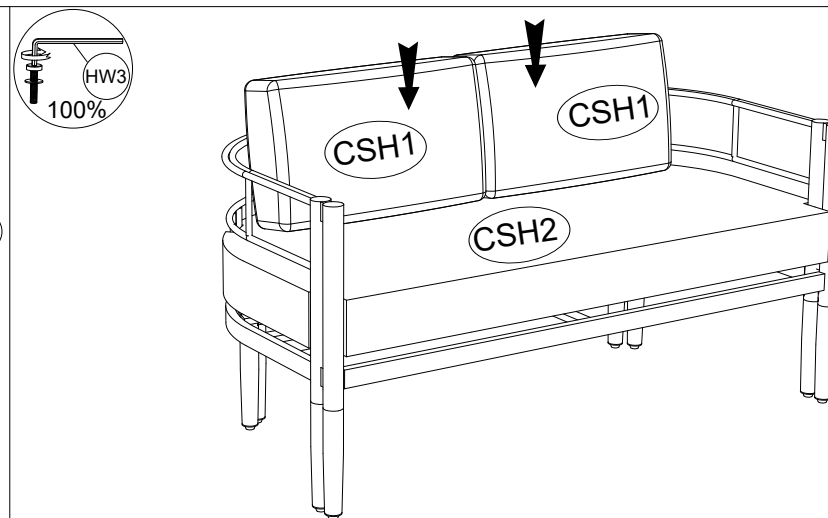

STEP 4: Firmly tighten all the Bolts with Allen Key (HW3). Put the Bench upright, put the Cushion (CSH1) & (CSH2) on Bench.

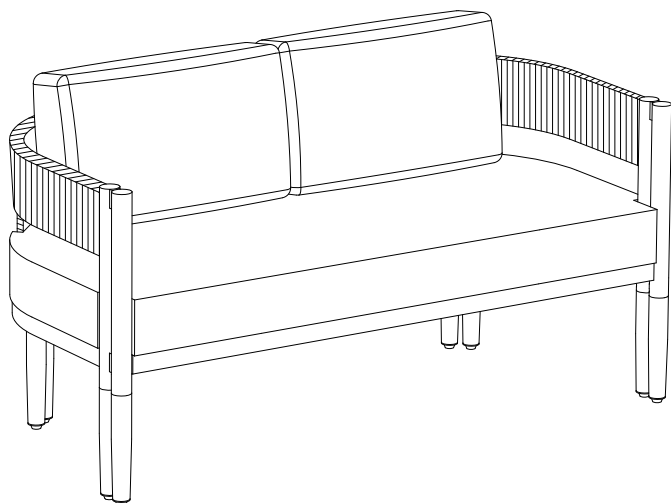

Finish Bench

