

Thank you for purchasing a Chair & Table Company product. This Product has been designed for easy assembly and is constructed for durability. Please take this time to read and follow the assembly Instructions carefully. If a part or hardware is missing or you have any difficulties in assembling this product, please contact us.









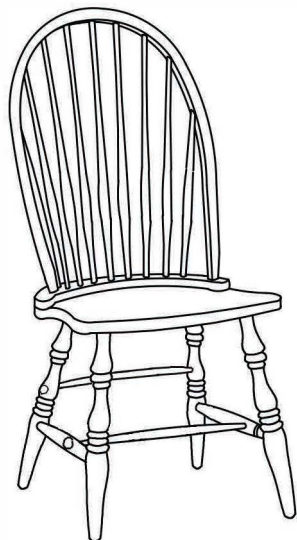

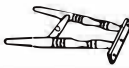

ASSEMBLY INSTRUCTION

NOTE: TOOLS REQUIRED-NOT SUPPLIED



WINDSOR CHAIR



PART LIST			HARDWARE LIST		
NO	DESCRIPTION	QTY	NO	DESCRIPTION	QTY
1	Chair Back Assembly 	1 PC	A	Jcbc Screw M6 X 60MM 	4 PCS
2	Chair Seat 	1 PC	B	Jcbc Screw M6 X 35MM 	10 PCS
3	Chair Leg (L) 	1 PC	C	Spring Washer M6 	14 PCS
4	Chair Leg (R) 	1 PC	D	Barrel Nut 	4 PCS
5	Center Stretcher (Long) 	1 PC	E	Wood Button 	4 PCS
6	Back Stretcher (Short) 	1 PC	F	Allen key M4 	1 PC
			G	Adjustable Leveller 	4 PCS

Step 1

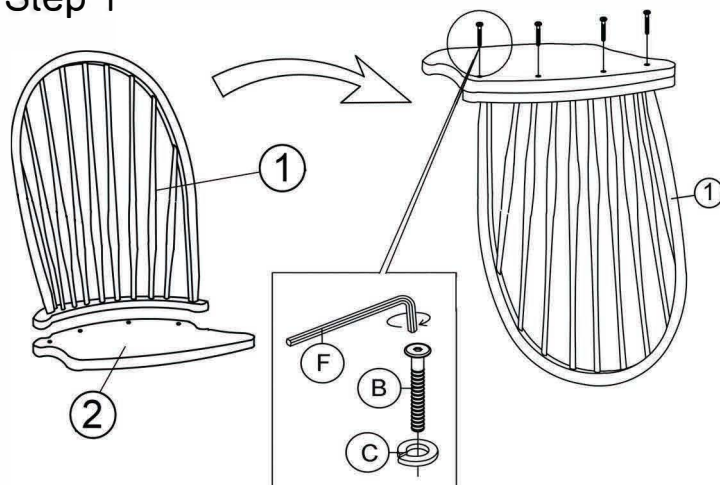

Step 2

Assemble front & back stretcher (5 & 6) to the Chair Legs (3 & 4), fix it by using Barrel Nut (D) and JCBC Screw (A) as shown.
Do not fully tighten the screw until final step.

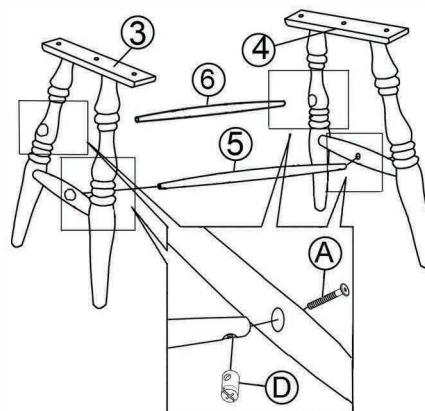

Step 3

Assemble chair leg frame to chair seat (2) with JCBC screw (B)
 Affix one Adjustable Levellers (G) to the bottom of each chair leg.

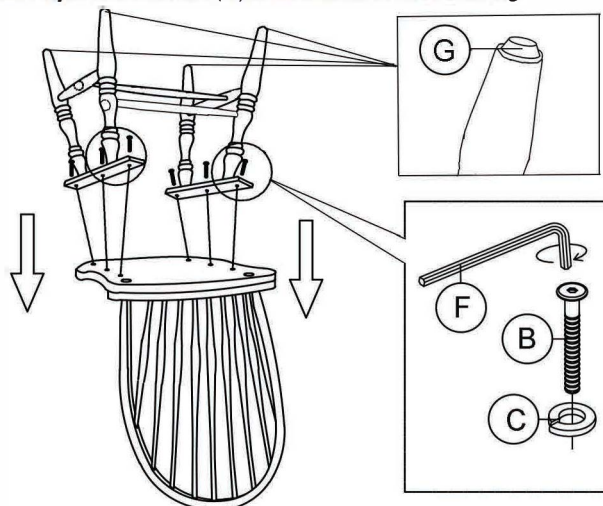

Step 4

Fully tighten all the screws, cover JCBC screw holes with Wood Buttons (E).

