

1		1/4"*17mm	6
2		1/4"*18mm	4
3		1/4"*35mm	8
4		1/4"*40mm	8
5		5/16"*25mm	4
6		3/16"*20mm	40
7		1/4"	8
8		1/4"	4
9		4mm Allen Key	1
10		Wrench	1

1 Components

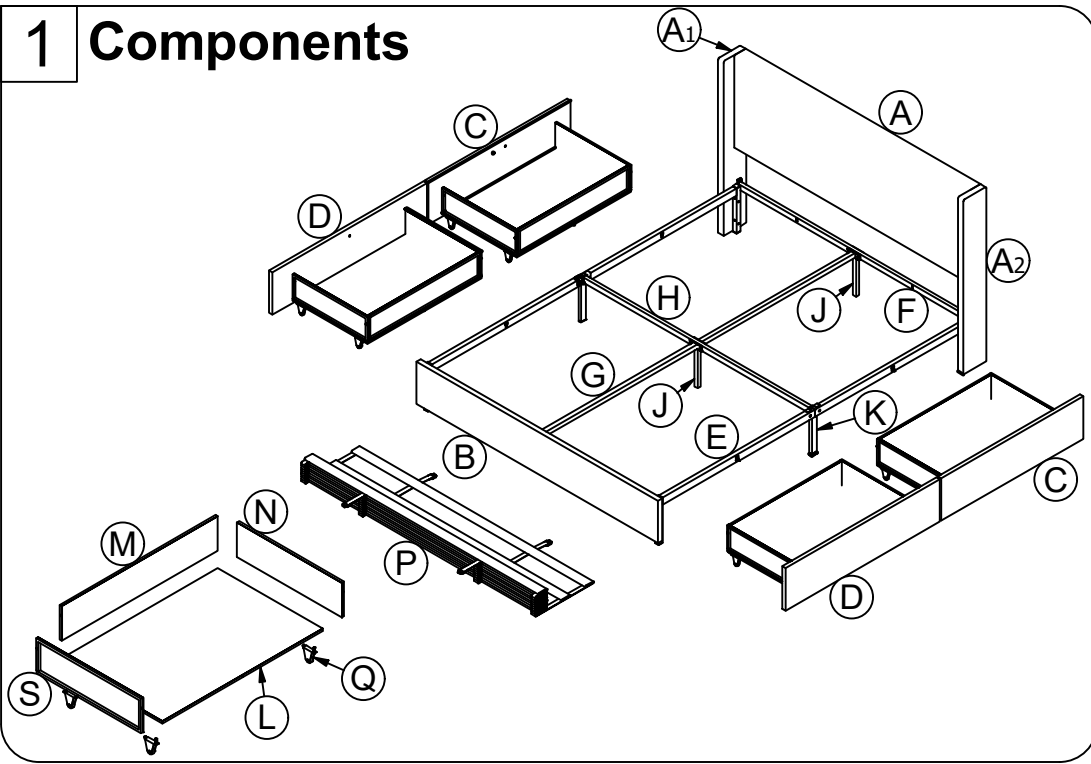

2 1. When replacement request, please tell us Component Alphabet and Model Number.
2. Fully tighten when **Step 7** finished.

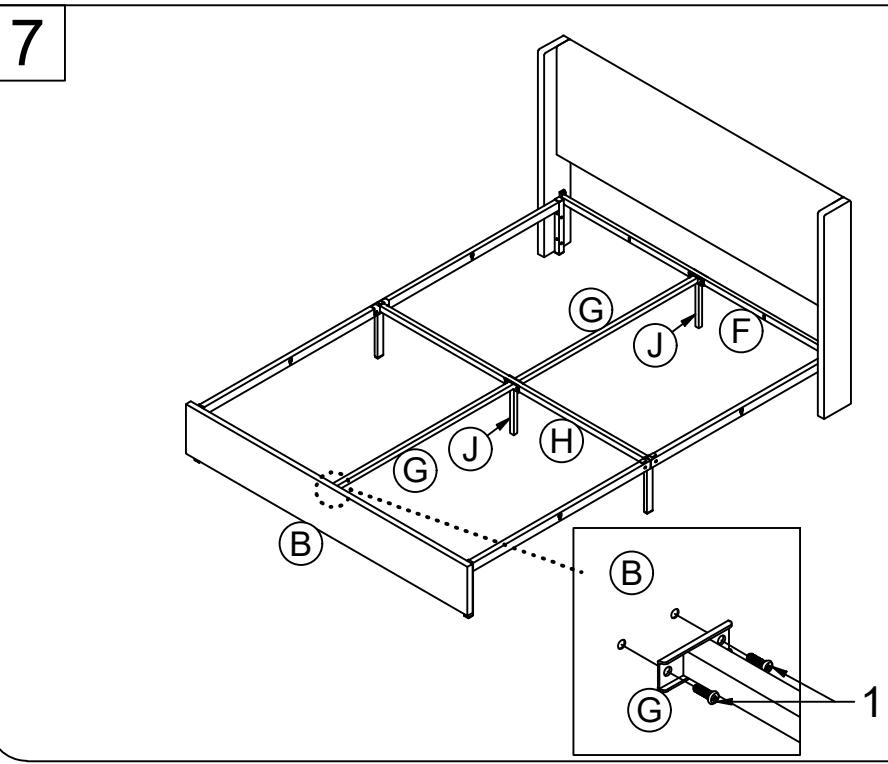
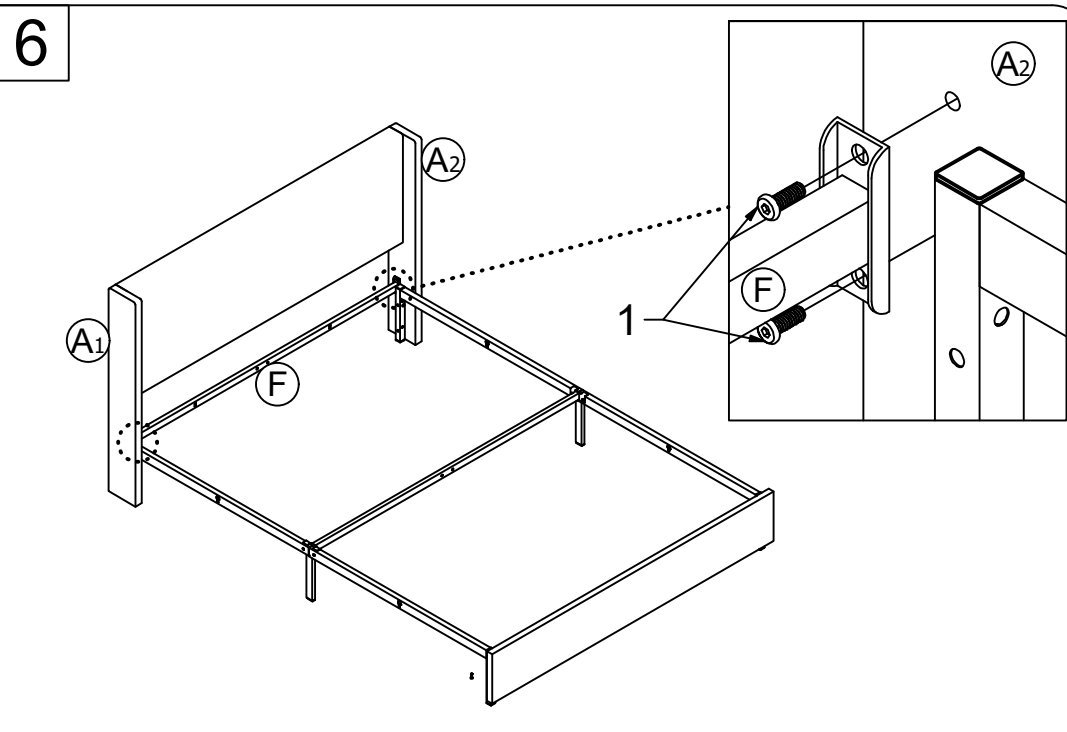
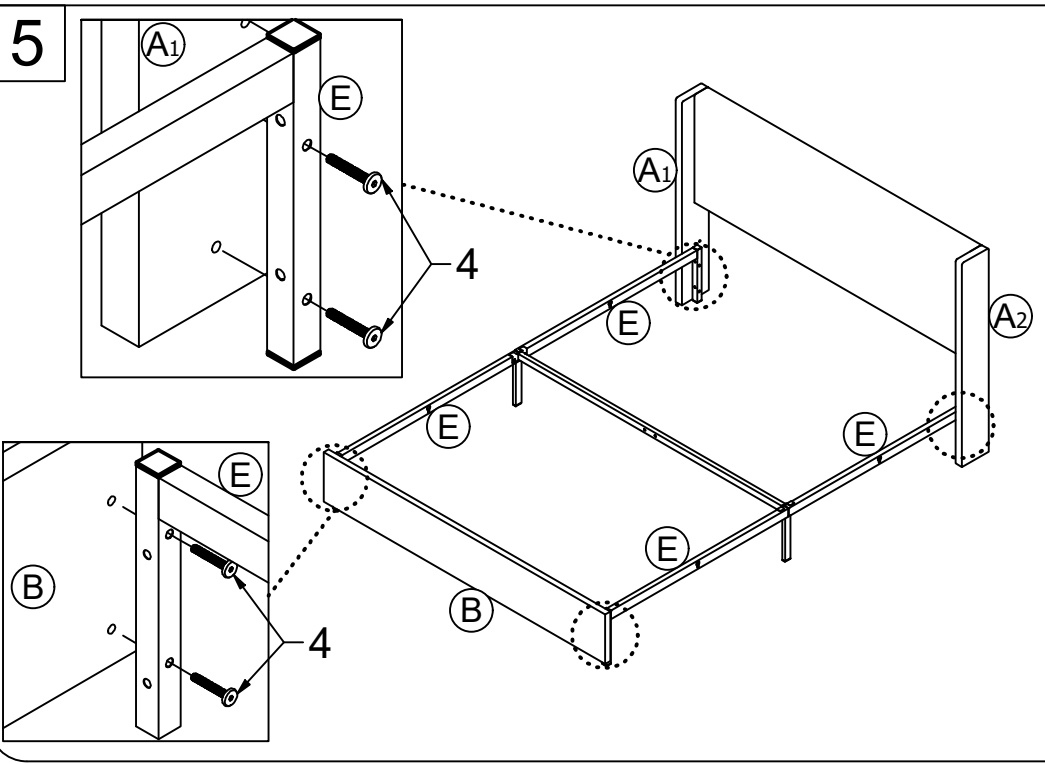
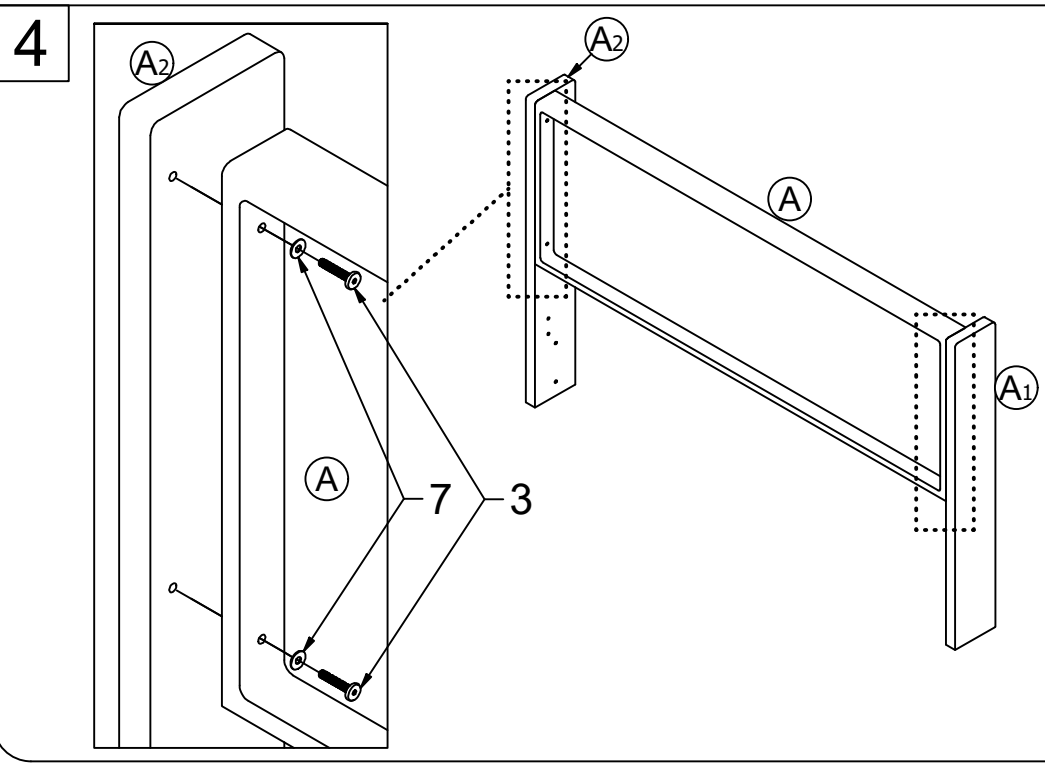
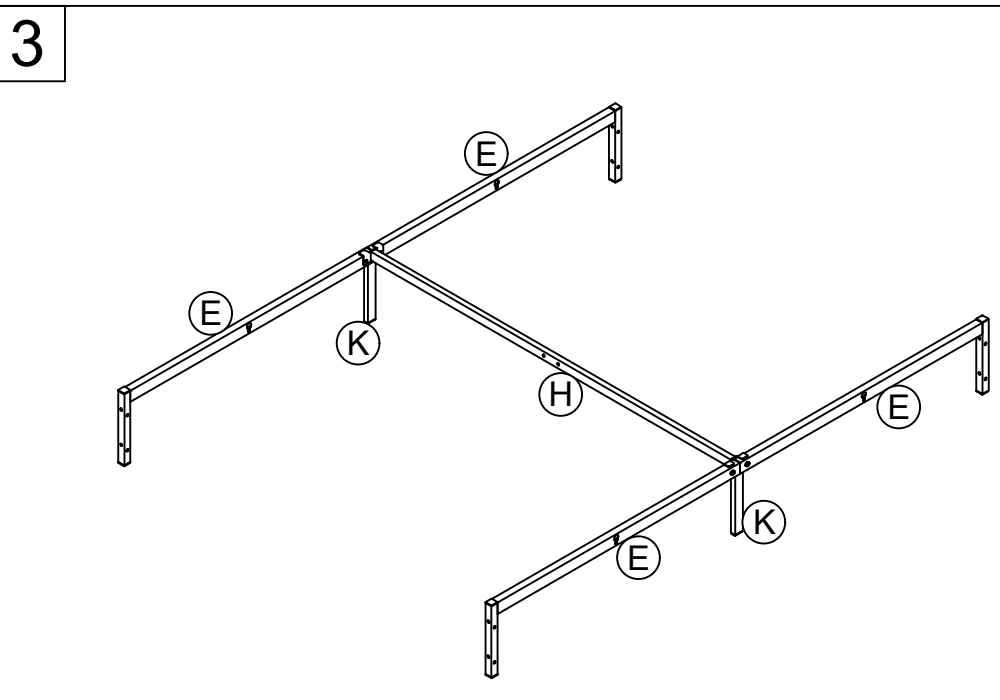
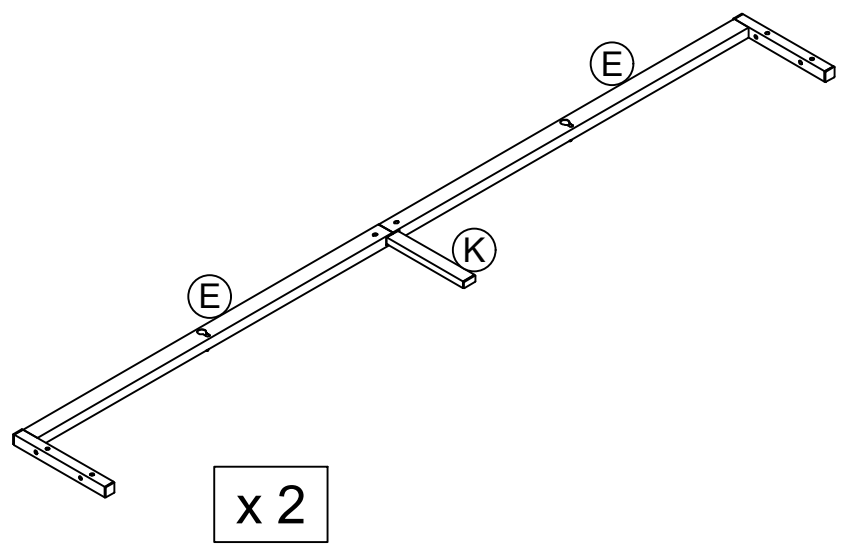

8

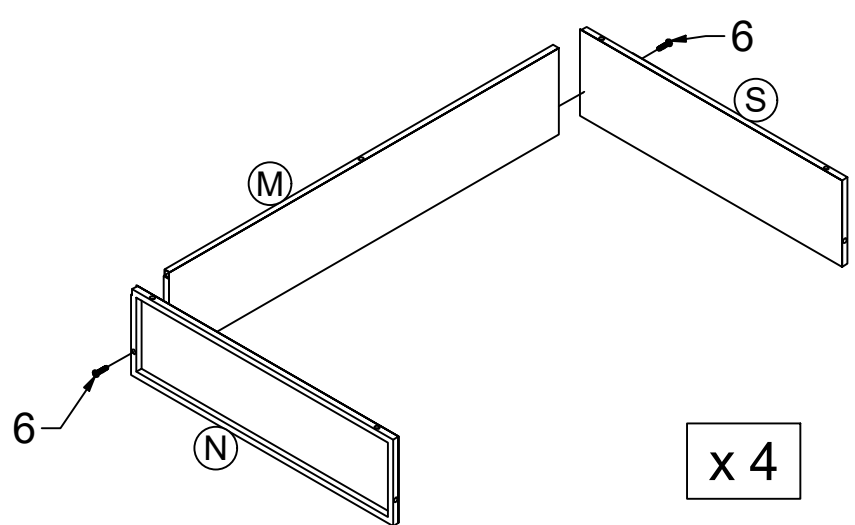

x 4

9

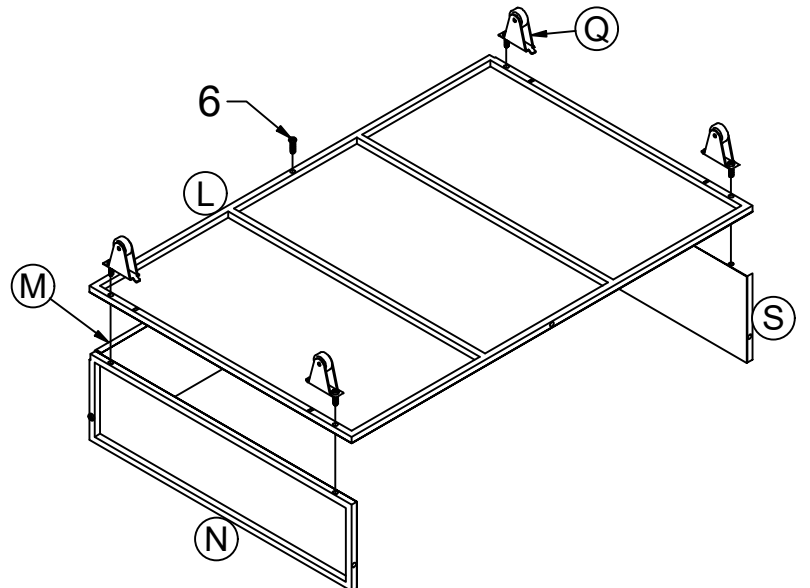

x 4

10

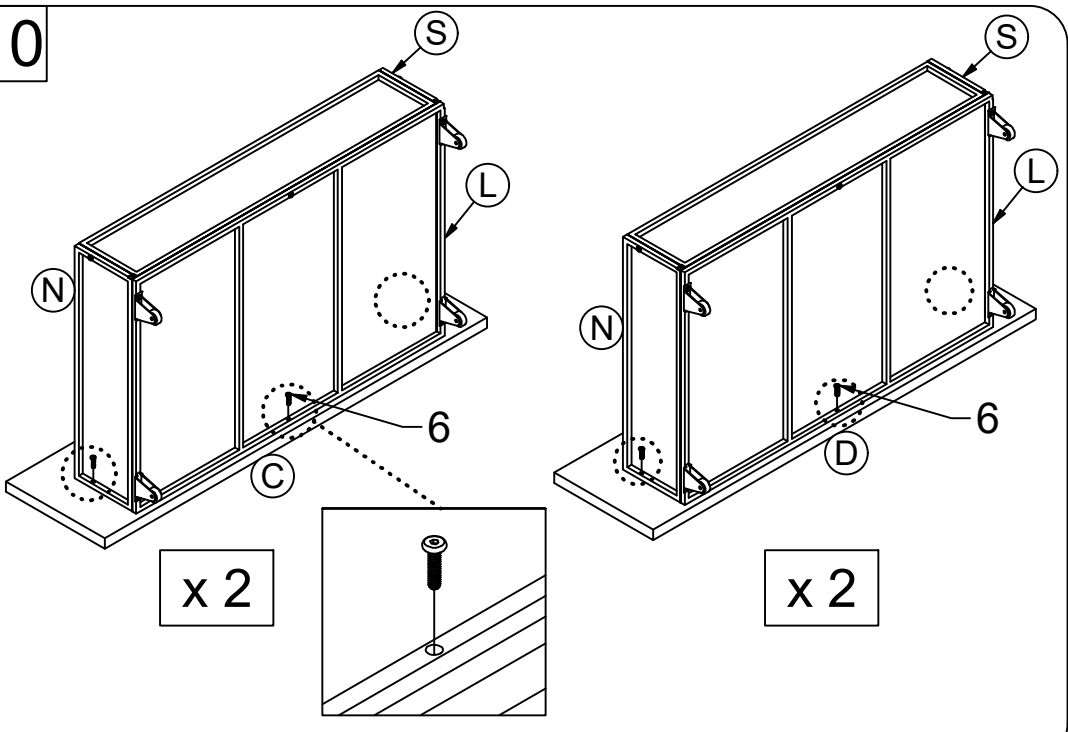

x 2

x 2

11

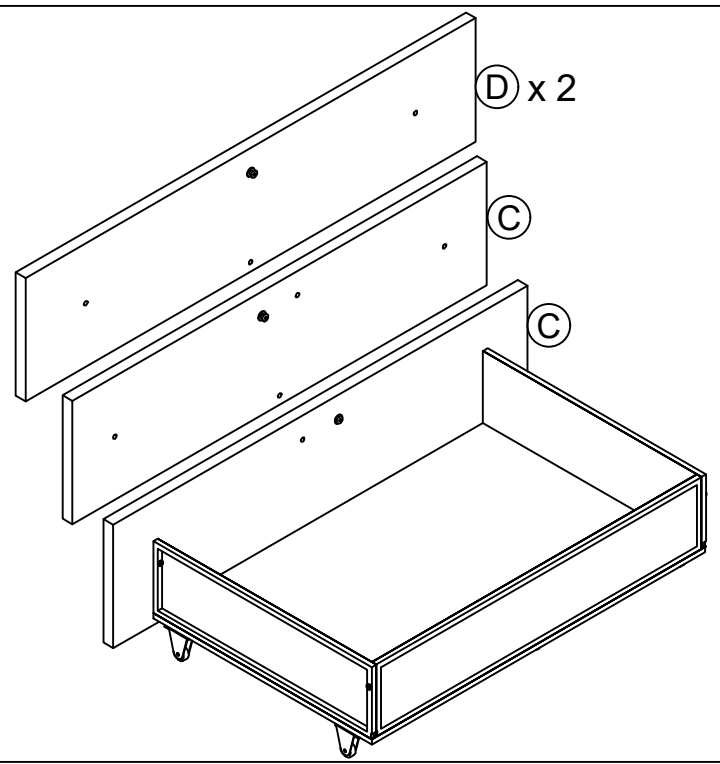

12

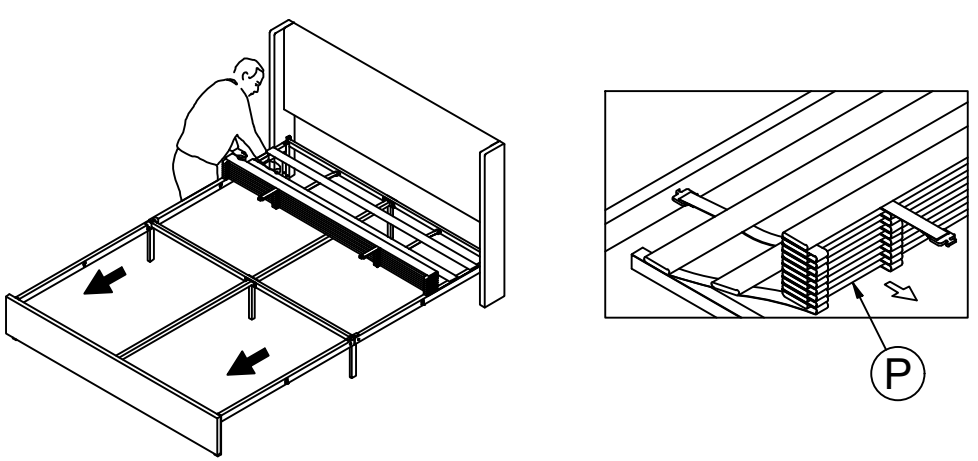

13

