

# ASSEMBLY INSTRUCTION

BLACK FINISH BROWN PVC 3PC PACK COUNTER HEIGHT SET WITH METAL LEG

**A** Table Top

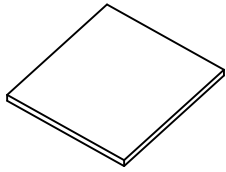

1PC

**B** Table Leg



4PCS

**C** Cross Tube

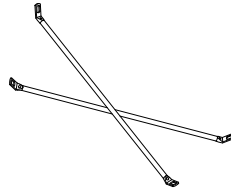

4PCS

**D** Bolt  
M6\*12mm



4PCS

**E** Bolt  
M6\*15mm



8PCS

**F** Flat Washer  
φ16mm



4PCS

**G** Allen Wrench  
4mm



1PC

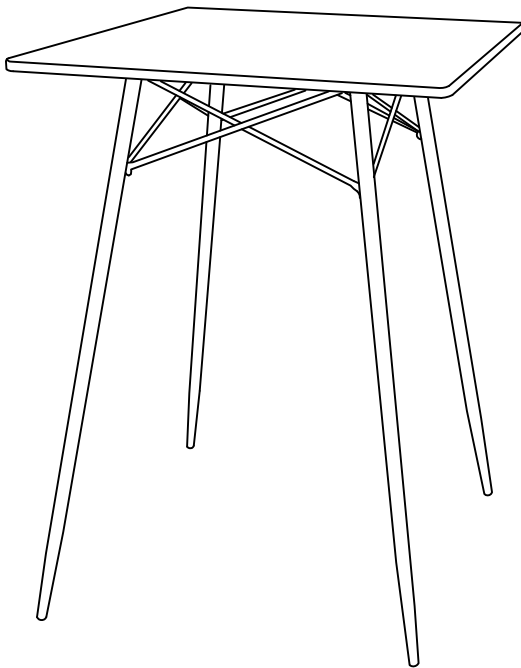

This page lists all the contents included in the box for table. Please take the time to identify the hardware as well as the individual components to this product. As you unpack and prepare for assembly, place the contents on a carpeted or padded area to protect them from damage.

**1** Take the Allen Wrench(G), assemble the table leg (B) into table top (A), with 4pcs bolt (D), 4pcs flat washer(F), and turn the bolts until the legs are secure.

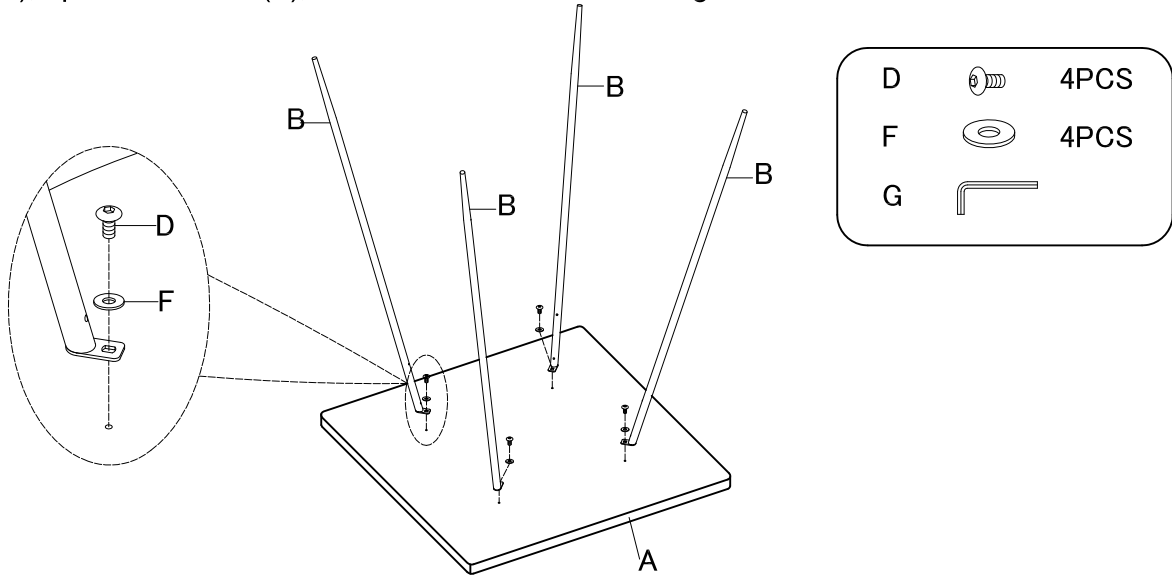

**2** Take the Allen Wrench(G), assemble the cross tube (C) on the bottom with 4pcs of bolt (E).

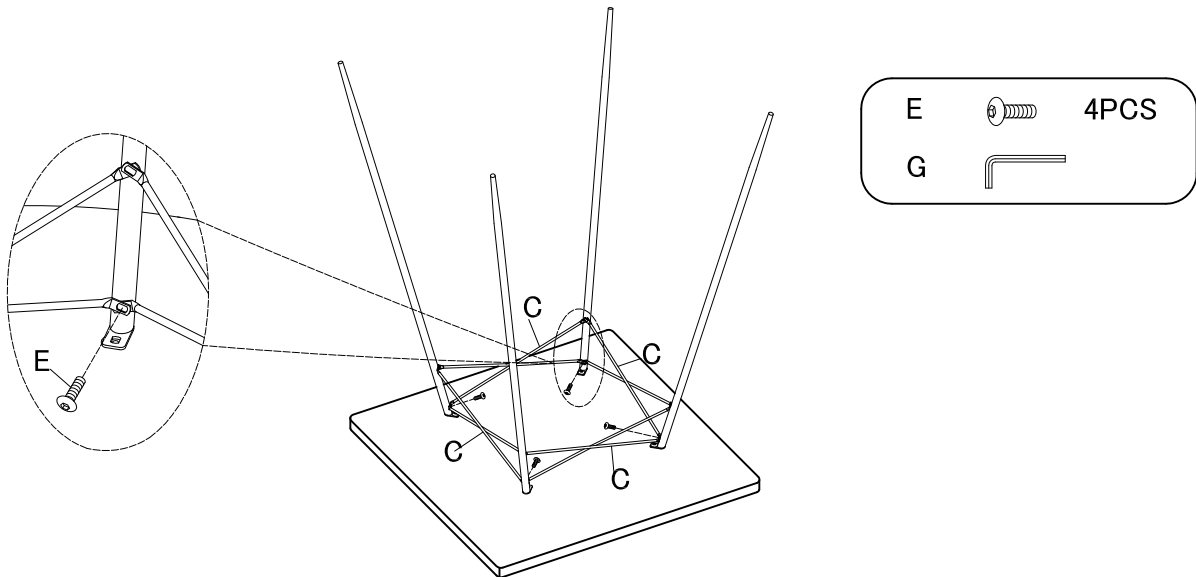

**3** Take the Allen Wrench(G), assemble the cross tube (C) on the top with 4pcs of bolt (E).

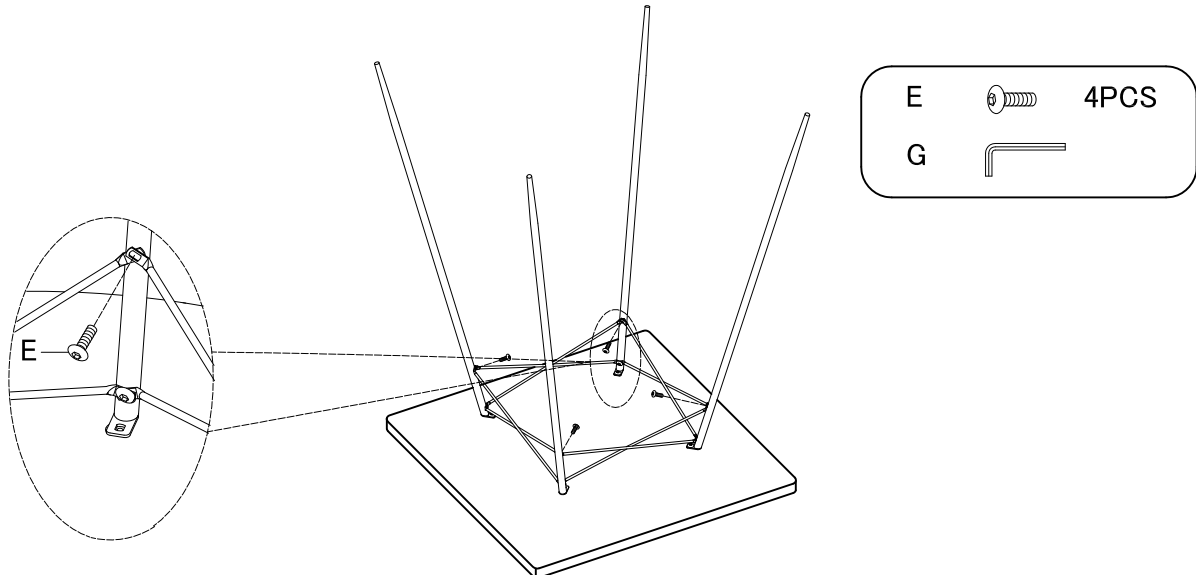

# ASSEMBLY INSTRUCTION

BLACK FINISH BROWN PVC 3PC PACK COUNTER HEIGHT SET WITH METAL LEG

**A** Seat

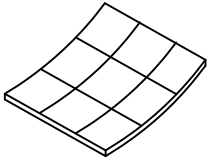

2PCS

**B** Chair Leg



8PCS

**C** Cross Tube

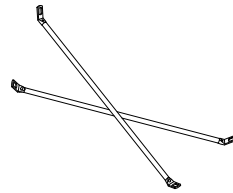

8PCS

**D** Seat Frame



2PCS

**E** Bolt  
M6\*15mm



24PCS

**F** Bolt  
M6\*25mm



8PCS

**G** Flat Washer  
φ16mm



8PCS

**H** Allen Wrench  
4mm



1PC

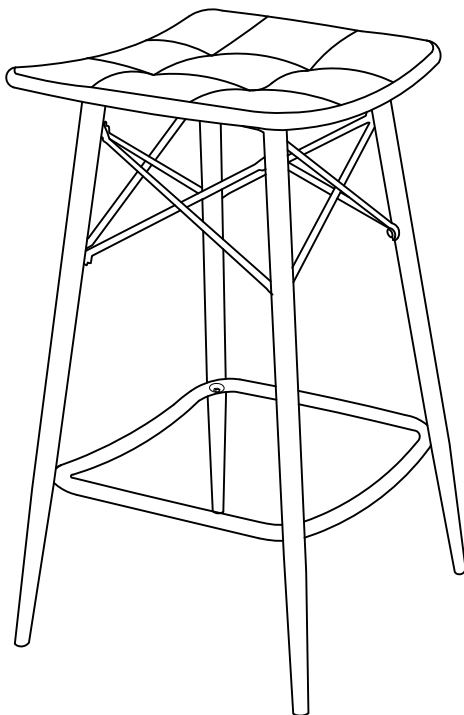

This page lists all the contents included in the box for chair.

Please take the time to identify the hardware as well as the individual components to this product. As you unpack and prepare for assembly, place the contents on a carpeted or padded area to protect them from damage.

- 1** Take the Allen Wrench(H), assemble the chair leg (B) into the seat (A), with 4pcs bolt (E), 4pcs flat washer(G) and turn the bolts until the legs are secure.

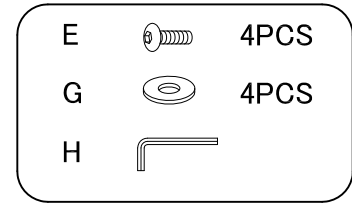
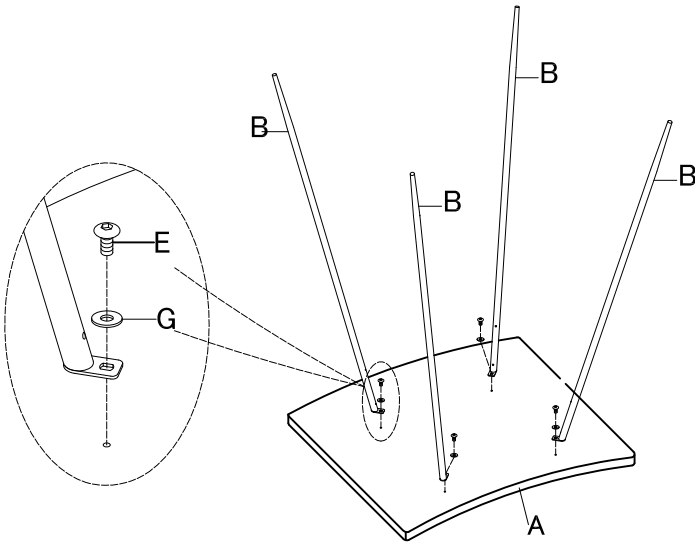

**DO NOT TIGHTEN COMPLETELY.**  
Stop when you feel you are adding force to tighten the bolt.

- 2** Take the Allen Wrench(H), assemble the cross tube (C) on the bottom with 4pcs of bolt (E), **DO NOT TIGHTEN COMPLETELY.** Stop when you feel you are adding force to tighten the bolt.

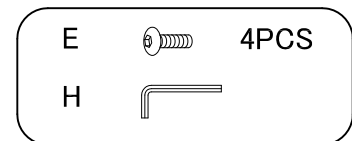
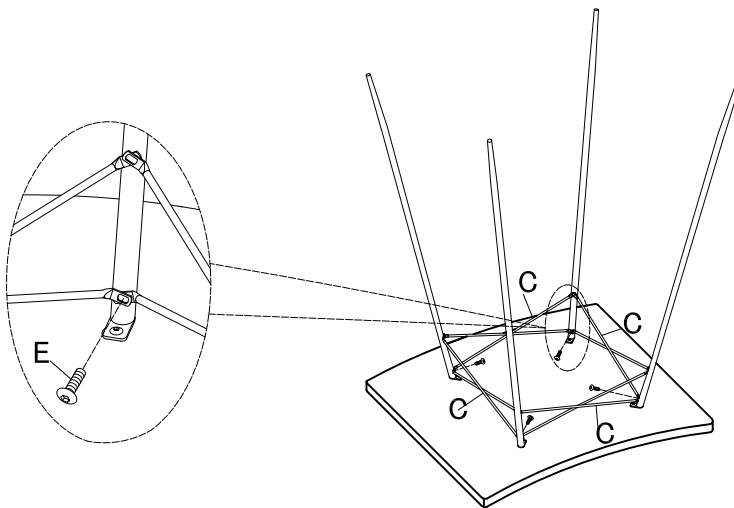

**3**

Take the Allen Wrench(H), assemble the cross tube(C) on the bottom with 4pcs of bolt (E). DO NOT TIGHTEN COMPLETELY. Stop when you feel you are adding force to tighten the bolt.

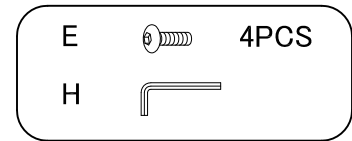
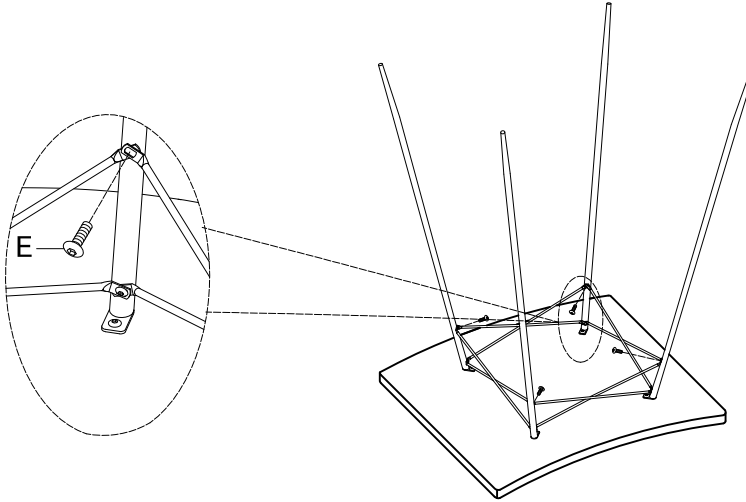
**4**

Take the Allen Wrench(H), assemble the seat frame (D) with 4pcs bolt (F). DO NOT TIGHTEN COMPLETELY. Stop when you feel you are adding force to tighten the bolt.

Stand chair up on an even surface and check that it is balanced. If there is a slight wobble, apply downward pressure in the corner where a leg is uneven. Keeping pressure in that corner, tighten all bolts. If balanced, apply downward pressure evenly in the center and tighten all bolts. Do not over-tighten beyond hole depth.

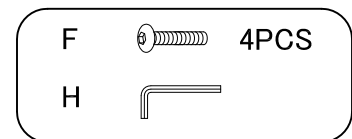
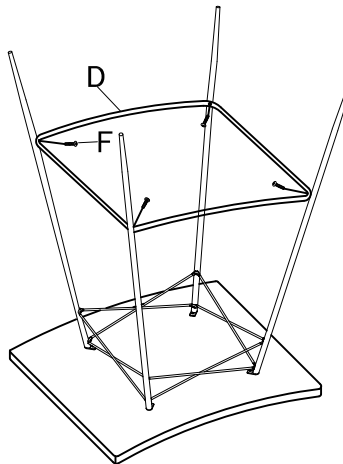

**Helpful Tip:**  
-Instead of applying downward pressure while reaching under to tighten bolts, have someone sit in the chair while you tighten the bolts.

#### Cleaning & Care

Treat surface with care. Surface is resistant to scratches but is not scratch resistant. Clean surfaces with a dry or damp soft cloth, Do not use abrasive cleaners. Hardware may loosen over time. Periodically check that all connections are tight.