









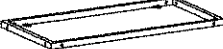
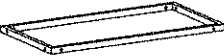
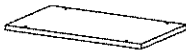
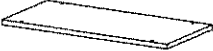

# ASSEMBLY INSTRUCTION

## CHARCOAL FINISH METAL AND WOOD KITCHEN

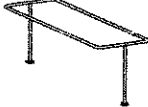
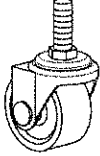
### CART

<b>A</b> Leg	<b>B</b> Wine Glass Holder Frame	<b>C</b> Bottom Frame	<b>D</b> Top Frame
			
4 pcs	1 pc	1 pc	1 pc
<b>E</b> Top Panel (Small)18T*757*350mm	<b>F</b> Bottom Panel (Big)18T*760*353mm	<b>G</b> Nut	<b>H</b> Bolt $\frac{11}{4} \times \frac{5}{8}$
			
1 pc	1 pc	16 pcs	16 pcs
<b>I</b> Bolt $\frac{11}{4} \times \frac{7}{8}$	<b>J</b> Bolt $\frac{11}{4} \times \frac{1}{2}$	<b>K</b> Wine Rack	<b>L</b> Wheel
			
2 pcs	12 pcs	1 pc	4 pcs
<b>M</b> Washer 14mm $\phi$	<b>N</b> Open End Wrench 13mm	<b>O</b> Allen Wrench 4mm	
			
4 pcs	1 pc	1 pc	

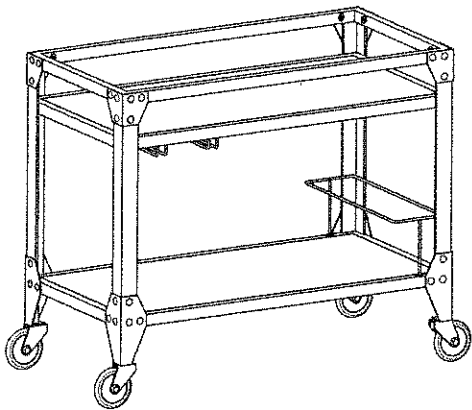

This page lists all the contents included in the box. Please take the time to identify the hardware as well as the individual components to this product. As you unpack and prepare for assembly, place the contents on a carpeted or padded area to protect them from damage.

**1**

Assemble leg (A) and top frame (D) as shown in drawing with bolt (H) and nut (G), fastening it up by use of allen wrench (O). Then install wine glass holder frame (B) and bottom frame (C) into place with bolt (J) on the ear tab in the corners.

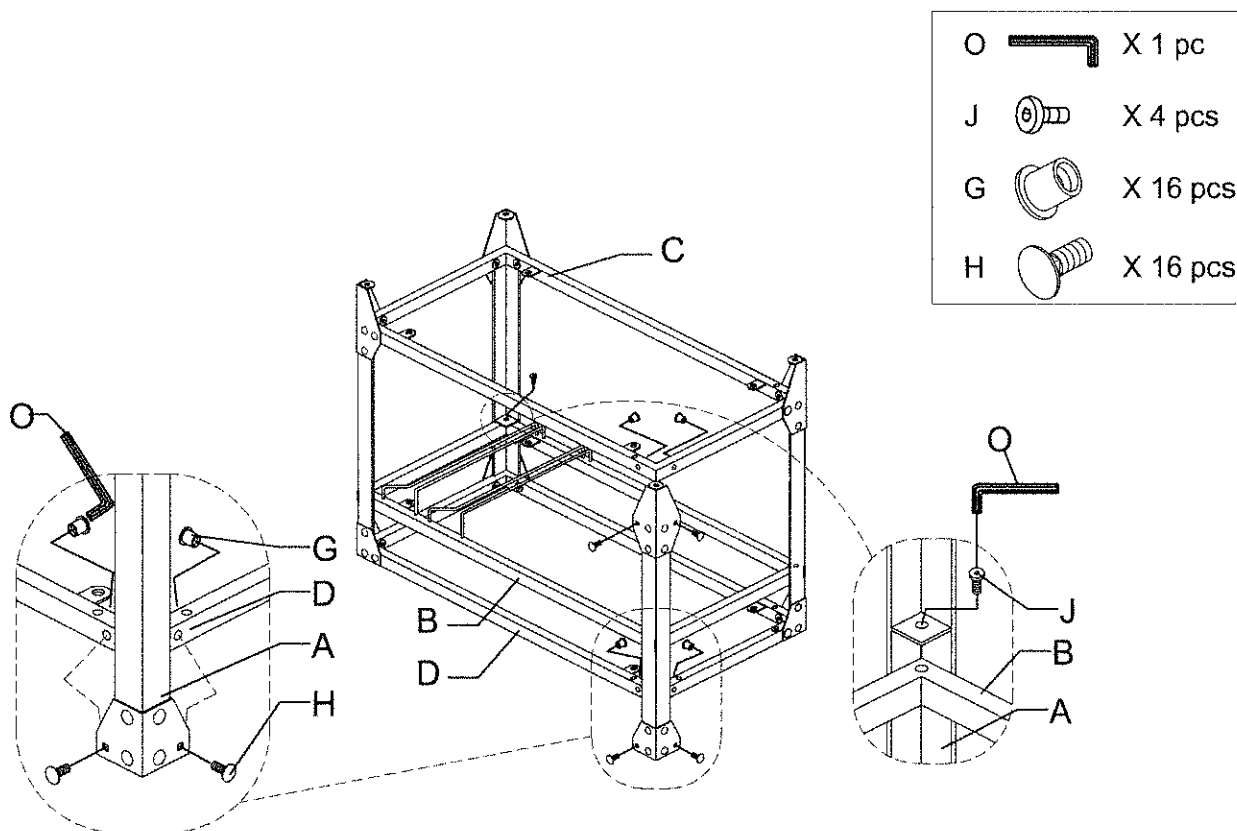
**2**

Install wheel (L) in the bottom of leg (A) as shown in drawing with washer (M) then tighten by open end wrench (N).

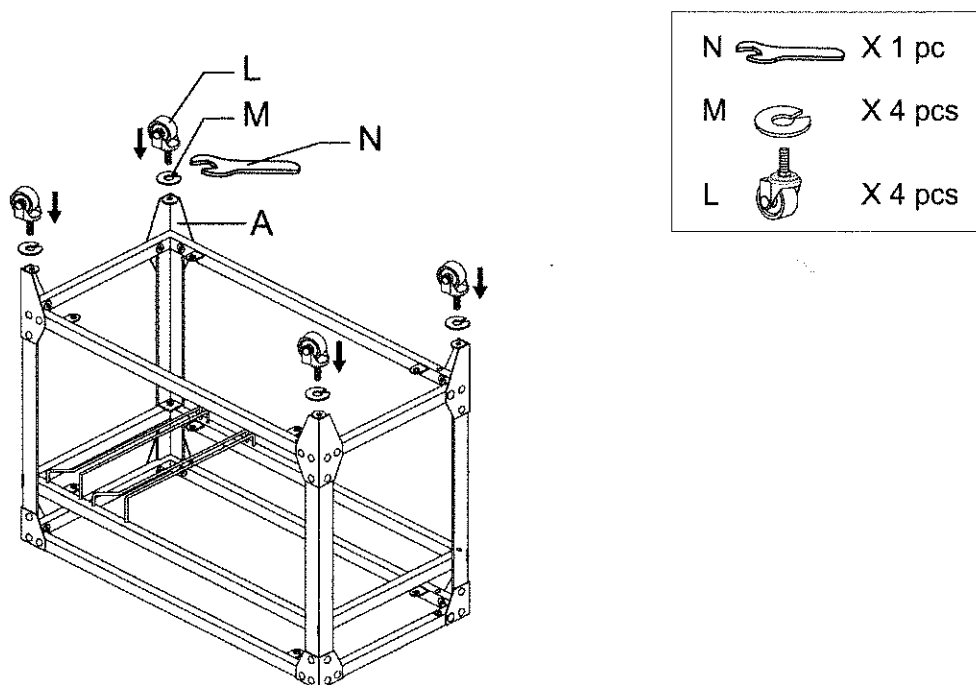

**3**

Assemble top panel (E) and bottom panel (F) to wine glass holder frame (B) and bottom frame (C) respectively with bolt (J) as shown in drawing. Then tighten up with allen wrench (O).

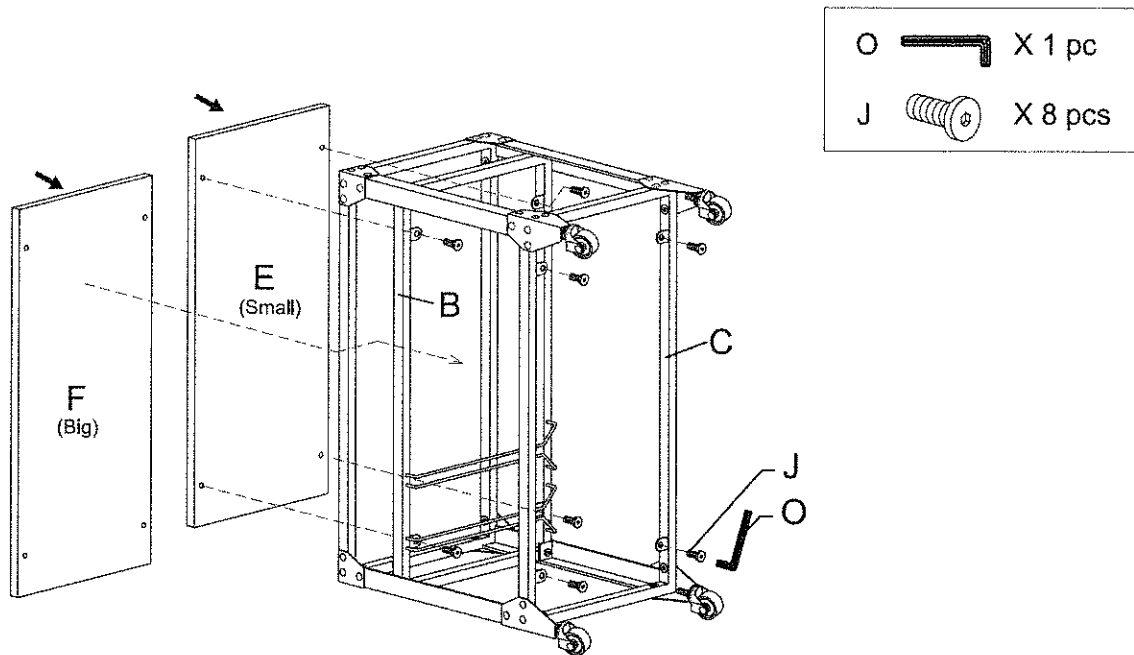
**4**

Upright the bar cart and install wine rack (K) on the bottom panel (F) with bolt (I) and fasten up with allen wrench (O).

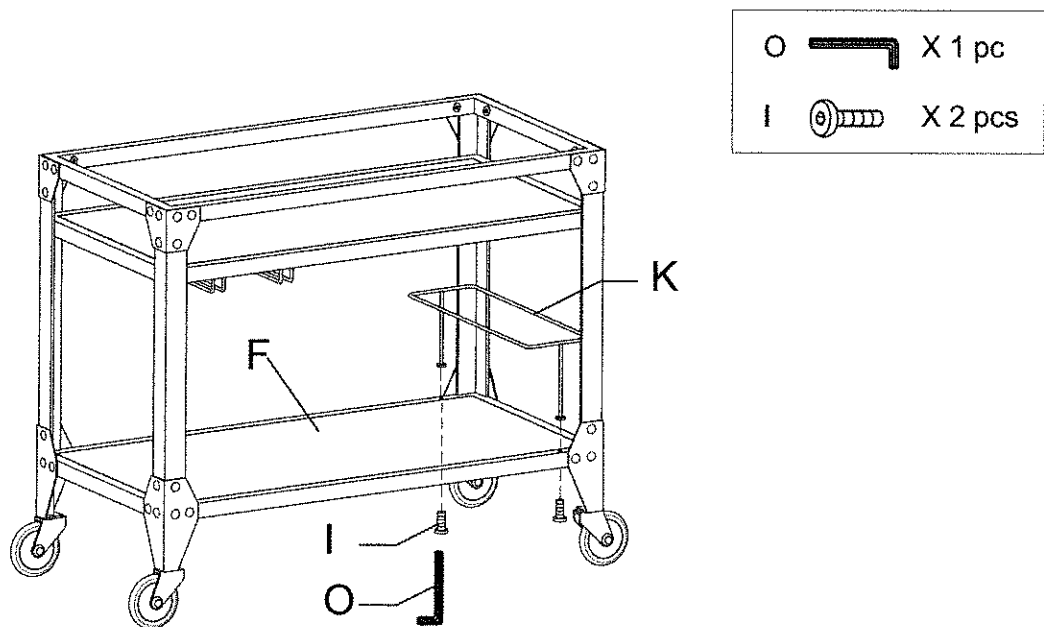

#### Cleaning & Care

Treat surface with care. Surface is resistant to scratches but is not scratch resistant. Clean surfaces with a dry or damp soft cloth. Do not use abrasive cleaners. Hardware may loosen over time. Periodically check that all connections are tight.