

ASSEMBLY INSTRUCTION

DESCRIPTION Panel Bed

Thank you for purchasing this quality product. Be sure to check all packing materials carefully for small parts which may have come loose inside the carton during shipment. Identify and count all parts and compare with the parts List Below.

Assembly steps:

Step 1. Assemble the Cross bar (G) to the Posts (L/R) (B) using Wood dowel (i), Bolt (e), spring washer (f), flat washer (g) and allen key (h).

Step 2. Assemble the Posts (B) to the Headboard (A) using Bolt (e), spring washer (f), flat washer (g) and allen key (h).

Step 3. Assemble the Side rails (D) to the Posts (B) and Footboard (C) using set-screw (a), washer (b), nut (c) and wrench (d).

Step 4. Attach the Slat support (F) to the Slat (E)

Step 5. Screw slats (E) in place using screws (j).

PARTS LIST

NO.	SKETCH	DESCRIPTION	Q'TY
A		Headboard	1pc
B		Post (L/R)	2pcs
C		Footboard	1pc
D		Side Rails	2pcs
E		Queen	4pcs
		King	5pcs
F		Queen	8pcs
		King	10pcs
G		Cross bar	1pc

HARDWARE LIST

NO.	SKETCH	HARDWARE	Q'TY
a		5/16"x18x2-3/4"	8pcs
b			8pcs
c		5/16"	8pcs
d		12 mm	1pc
e		5/16"x18x2"	6pcs
f		5/16"x12 mm	6pcs
g		5/16"x19 mm	6pcs
h		4 mm	1pc
i		Ø8x30 mm	4pcs
j		Queen	8pcs
		King	10pcs

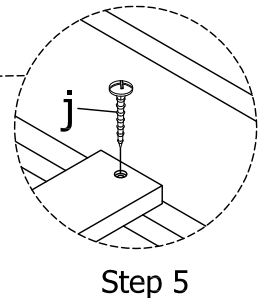
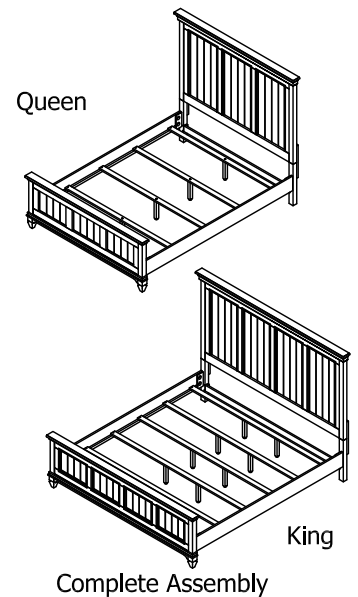
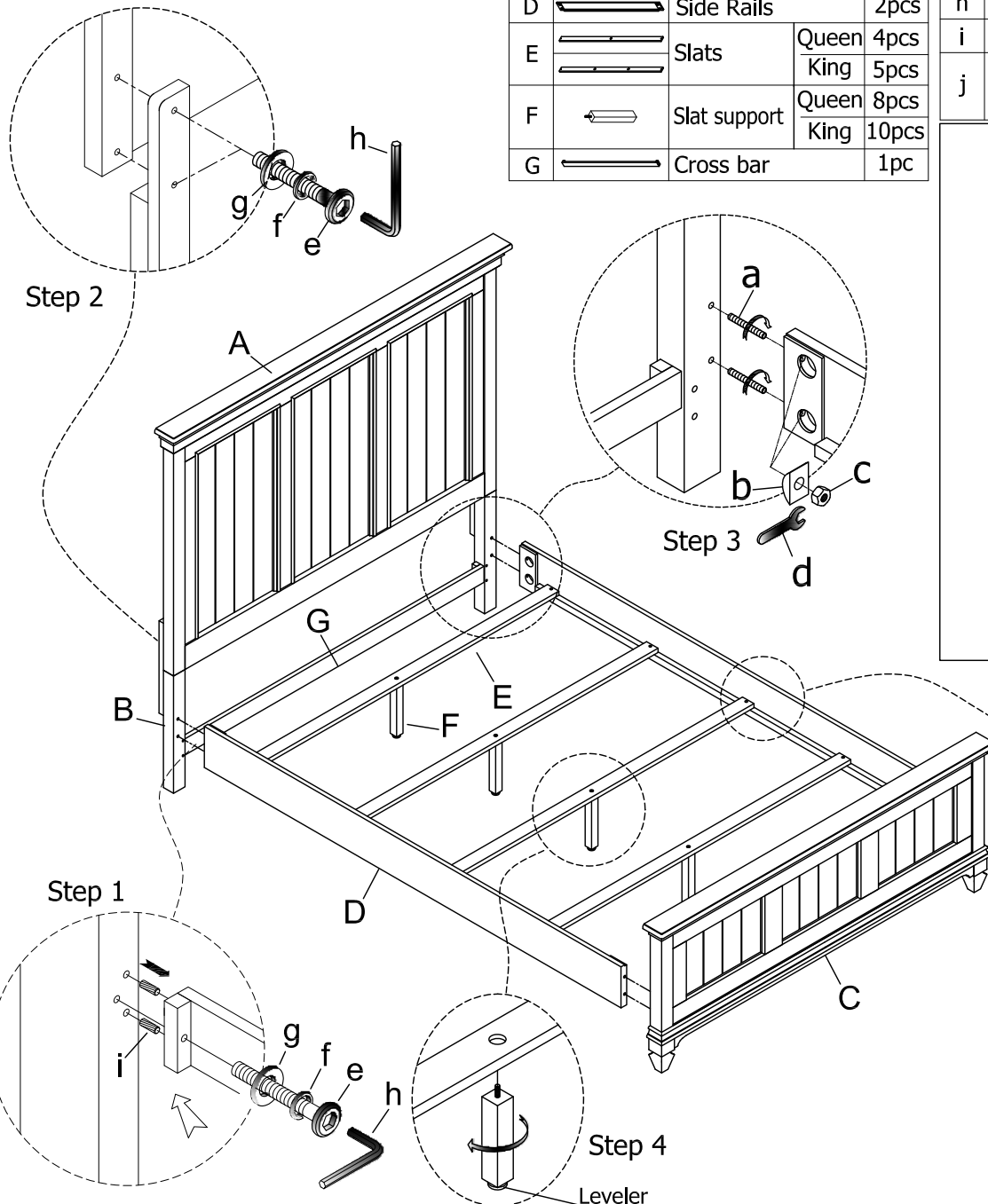

MADE IN VIETNAM