

Assembly Instructions

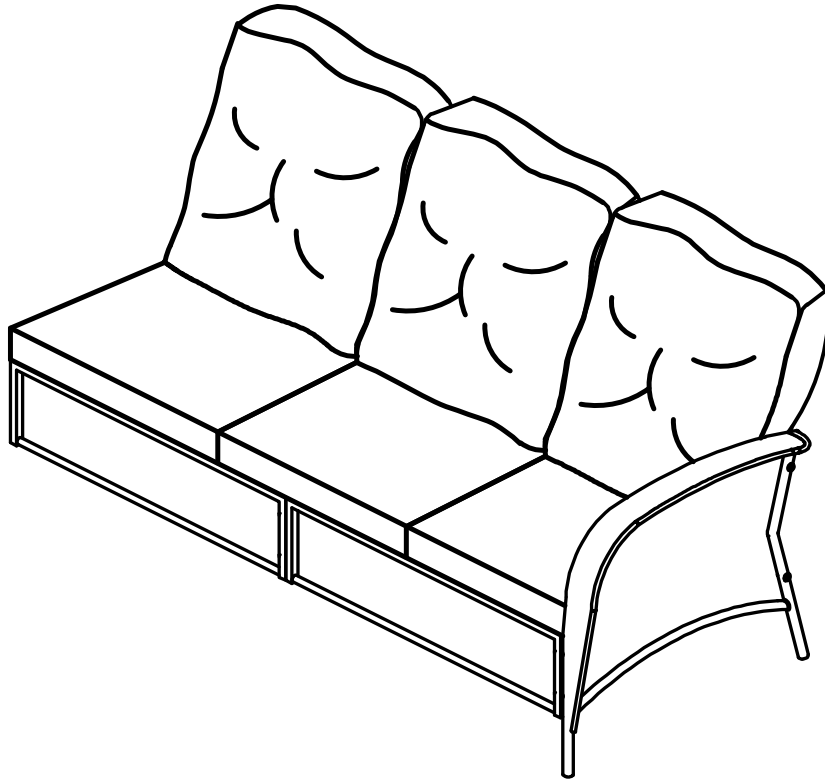

**Assembly
video**



For any missing hardware, damaged parts and other problems.
WELCOME to email us at: service@behousewell.com

Or call at 1-888-733-8169 Toll free
Between 9AM and 5PM Eastern time, Monday through Friday

***Don't fully tighten all the bolts till the very end!**

PRE-ASSEMBLY PREPARATION:

- A cordless drill is recommended for ease of assembly.
- Clear out the space for assembly and lay out all of the parts based on the Parts List, extra room will allow you to easily determine if all the pieces are present.
- Keep small parts and pieces away from children until fully assembled.



A1

Left
arm
1 pc

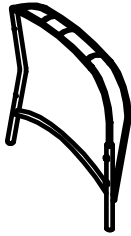

D

Left seat
1 pc

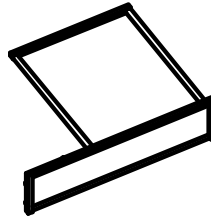

G

Middle
foot
1 pc

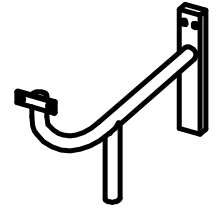

B

Right
back
1 pc

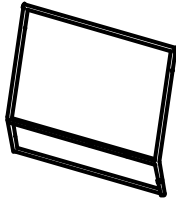

E

Middle
seat
1 pc

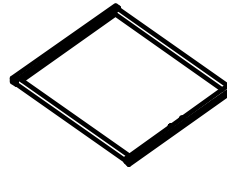

Q

3 pc seat
cushion

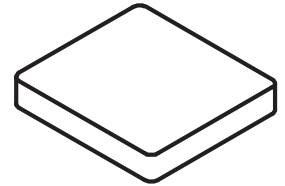

C

Left back
1 pc

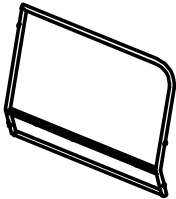

F



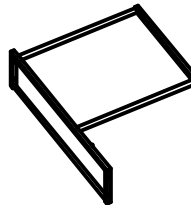

Right
seat
1 pc

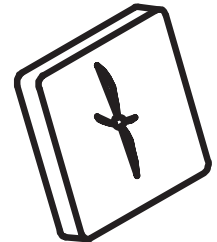

R

3pcs back
cushion

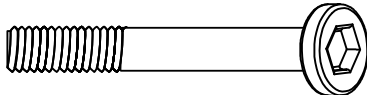
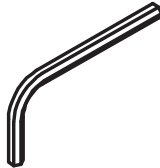
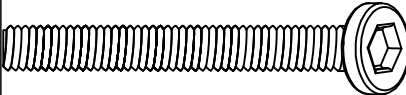
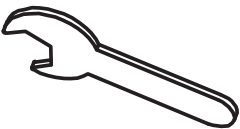
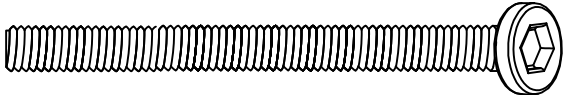

No.	Part/Size	QTY	Image	No.	Part/Size	QTY	Image	
H	Bolt (M6*20mm)	2	**Actural Scale 	M	Nut (M6)	4		
I	Bolt (M6*38mm)	16	**Actural Scale 	N	Wrench (M6)	1		
J	Bolt (M6*45mm)	2	**Actural Scale 	O	Cap	1		
K	Bolt (M6*65mm)	4	**Actural Scale 					
L	Washer (M6)	28		P	Cap	1		

Step 1: Attach back panels B&C with 2pcs bolts J and 2pcs washers L, using Allen wrench N. **Note: Please fully tighten the bolts.**

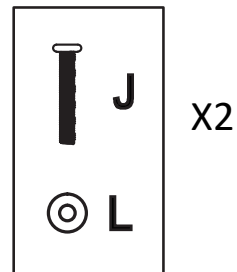
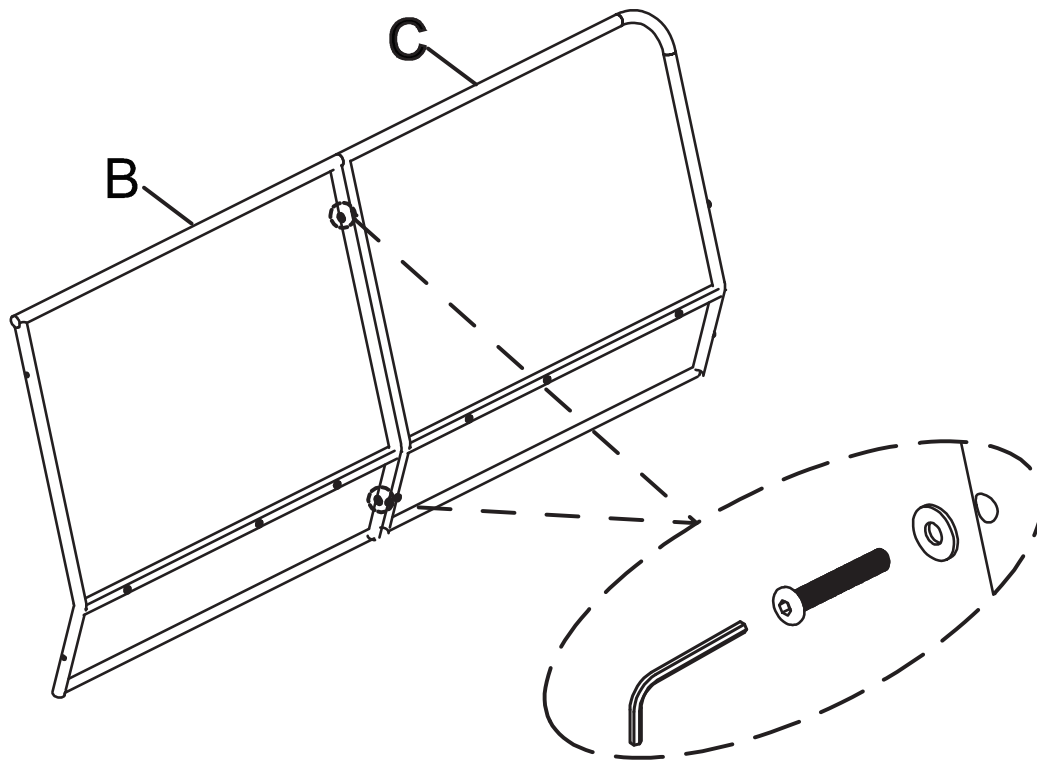

Step 2: Attach seat panels F&D with 2pcs bolts I and 2pcs washers L ,using Allen wrench N . Note:Don't fully tighten the bolts.

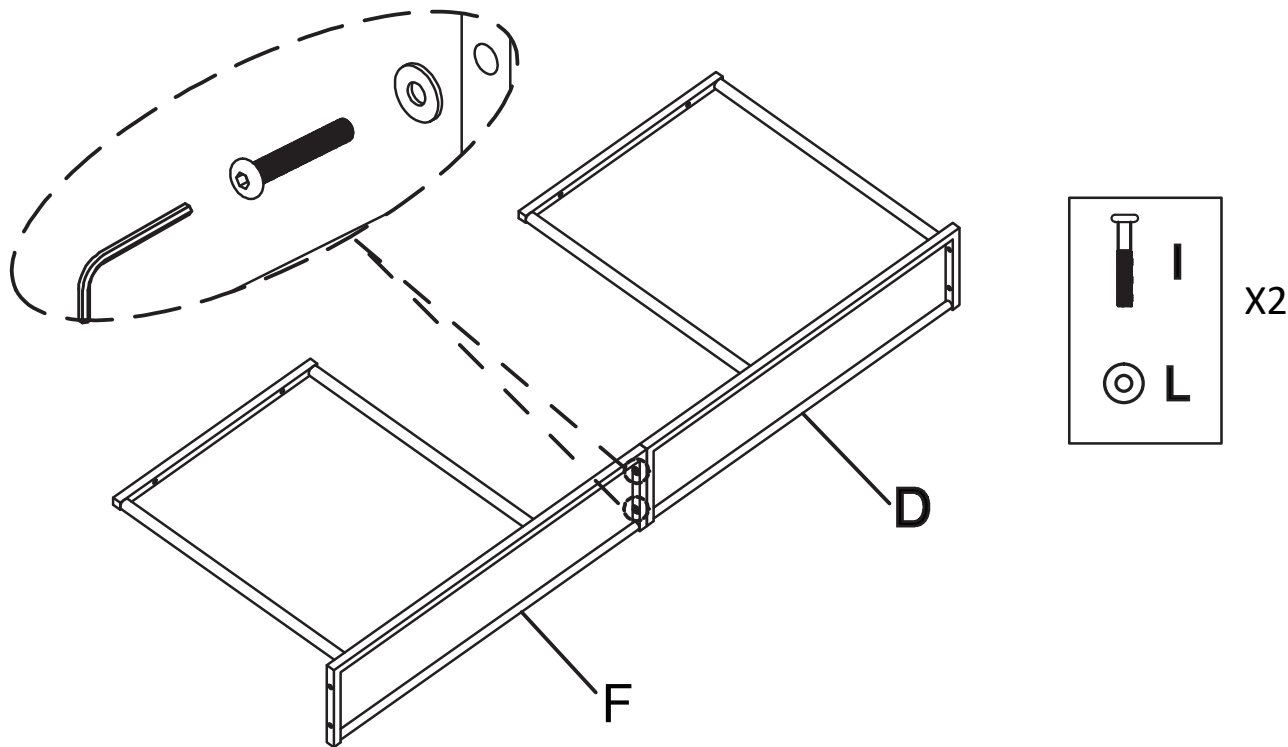

Step 3: Attach left arm A1 to back panel C with 2pcs bolts I and 2pcs washers L, using Allen wrench N. Note: Don't fully tighten the bolts.

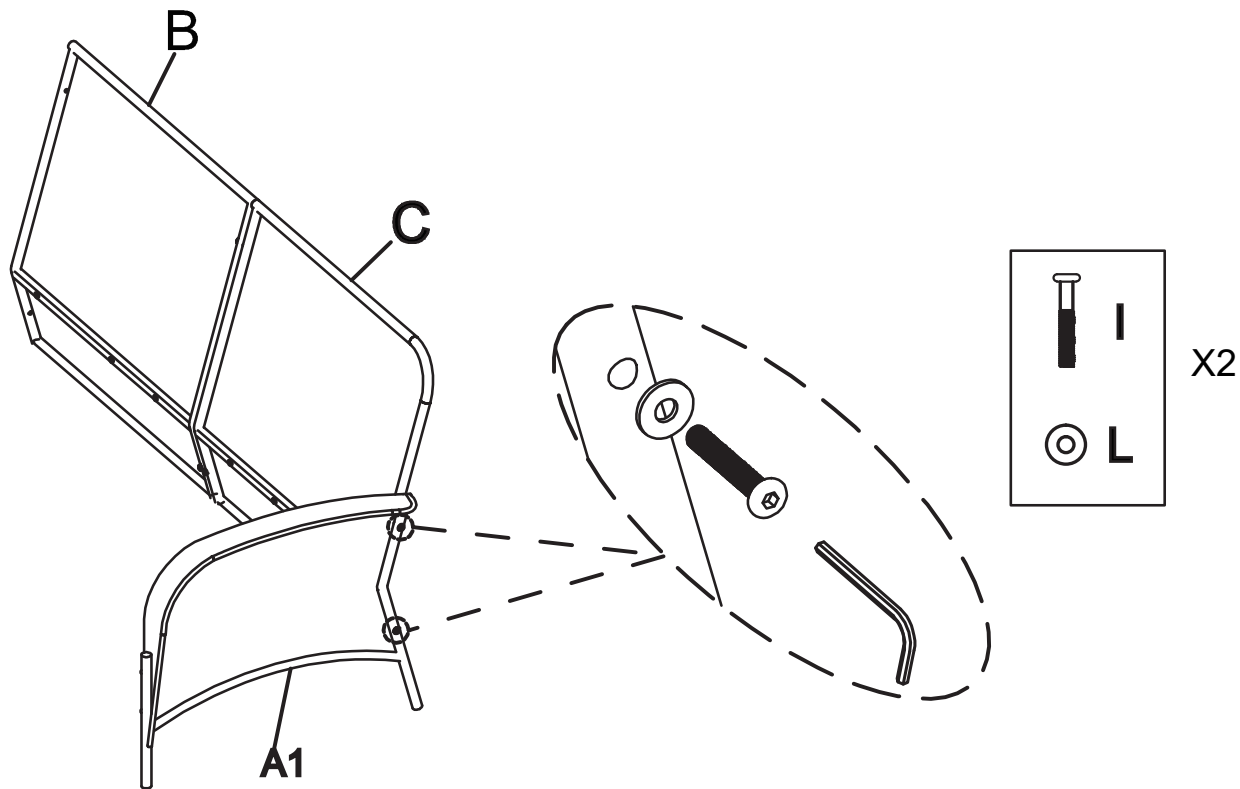

Step 4: Attach seat D to arm A1 with 2pcs bolts I and 2pcs washers L, using Allen wrench N. Note: Don't fully tighten the bolts.

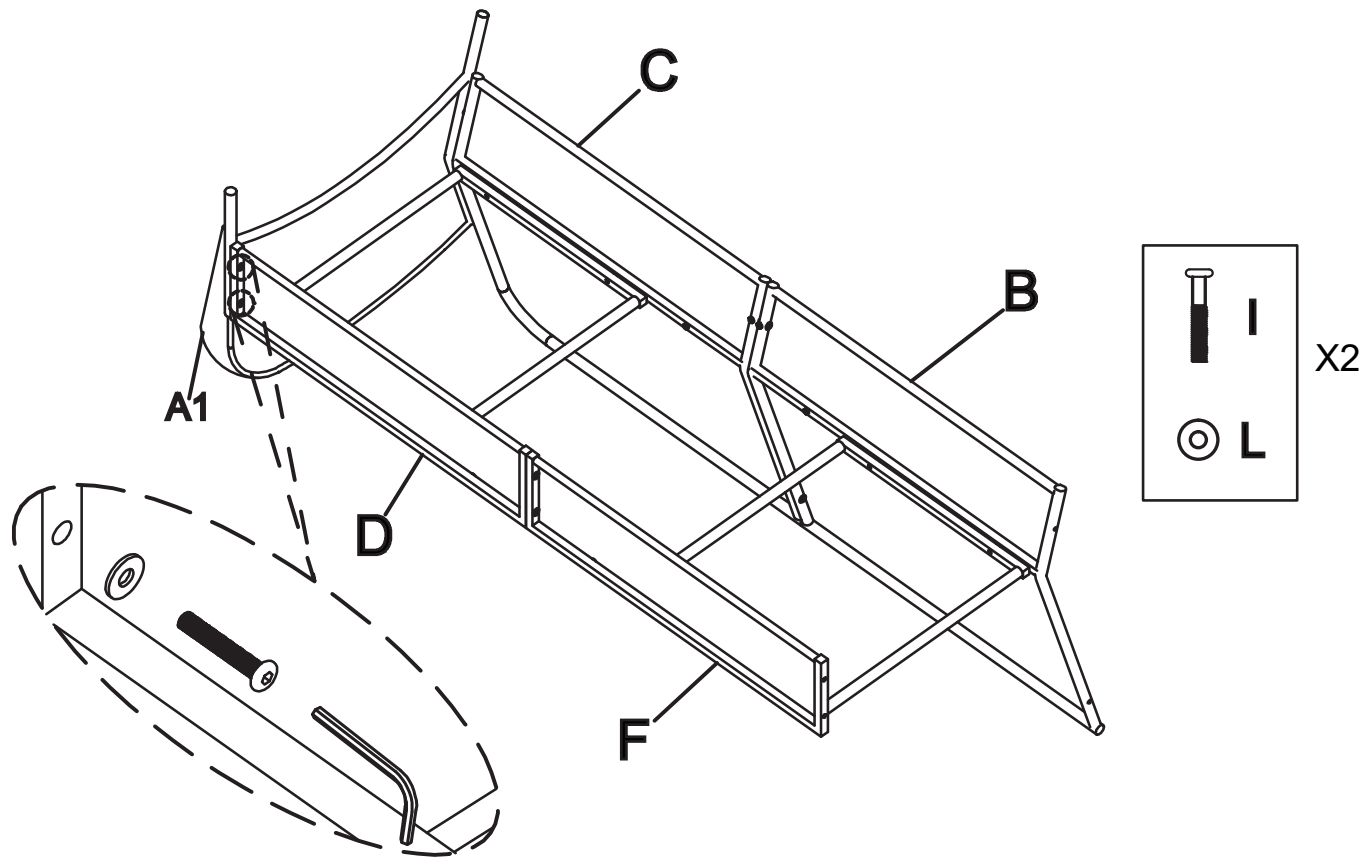

Step 5: Attach middle foot G to back panels with 2pcs bolts I ,2pcs washers L and 1pc washer P ,using Allen wrench N. Note:Don't fully tighten the bolts.

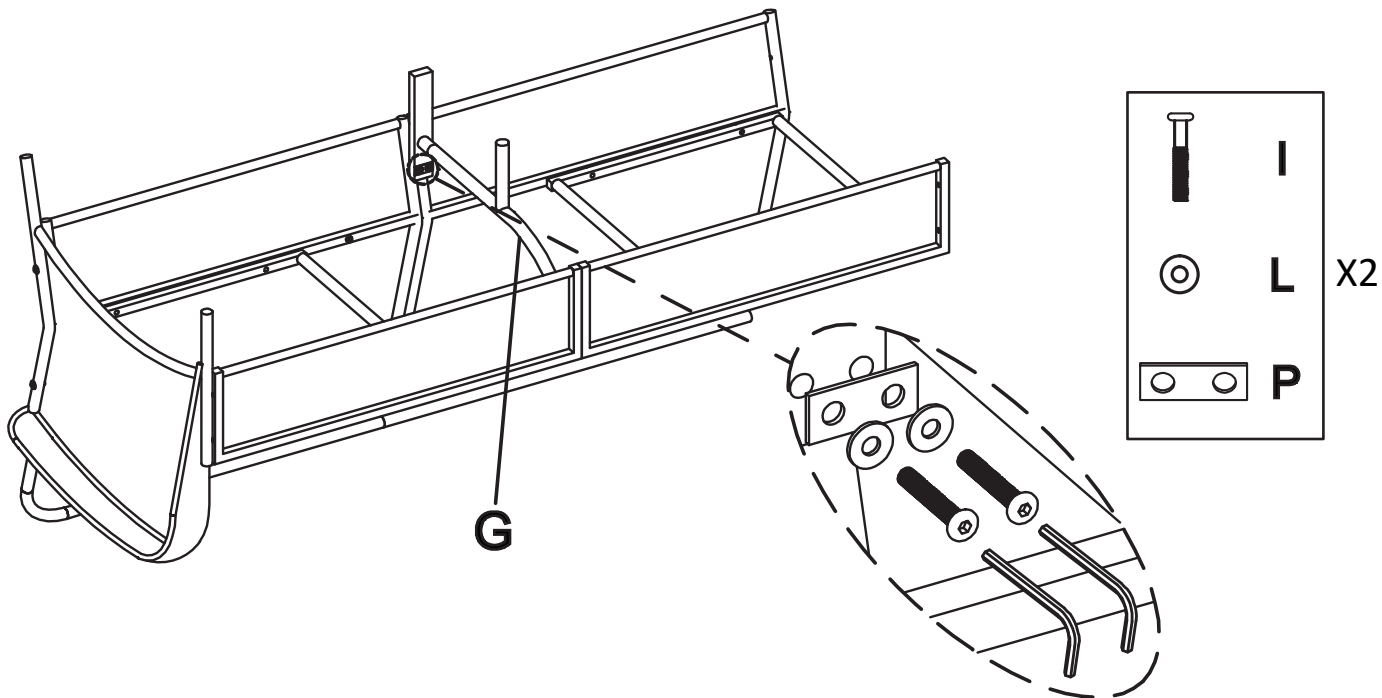

Step 6: Attach middle foot G to seat E with 2pcs bolts H and 2pcs washers L, using Allen wrench N. Note: Don't fully tighten the bolts.

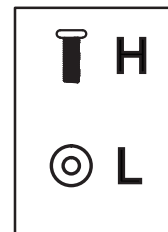
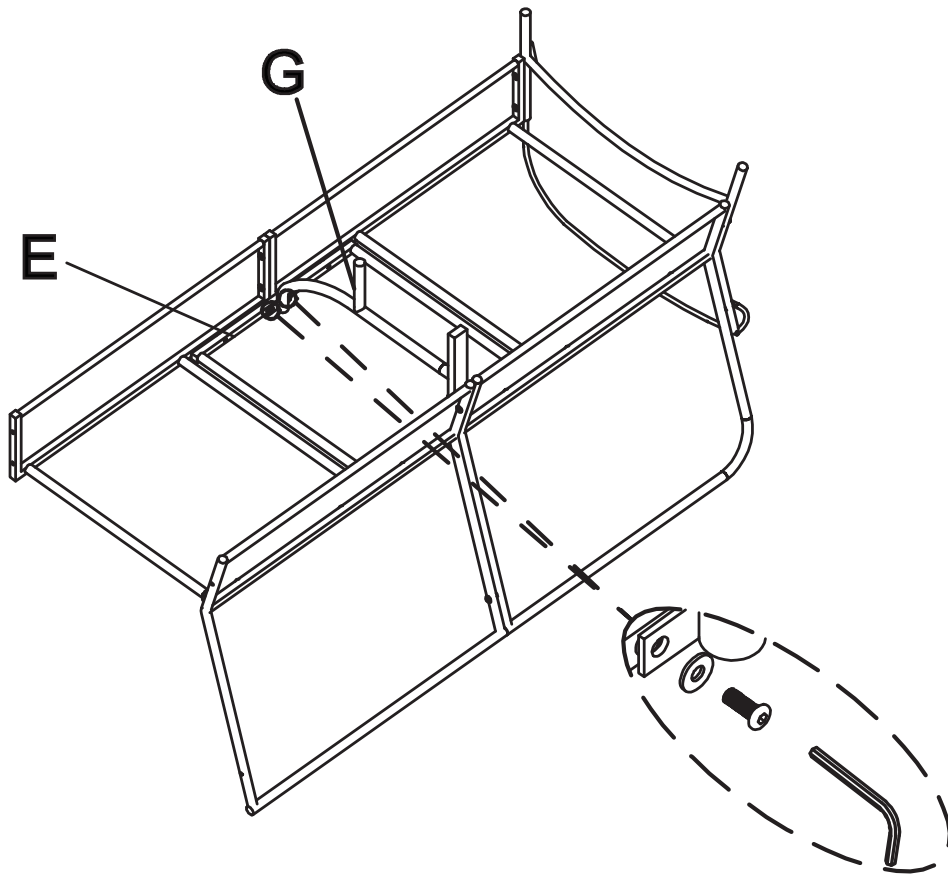

X2

Step 7: Attach Middle seat E to seat D&F with 2pcs bolts I and 2pcs washers L, using Allen wrench N .Note: Don't fully tighten the bolts.

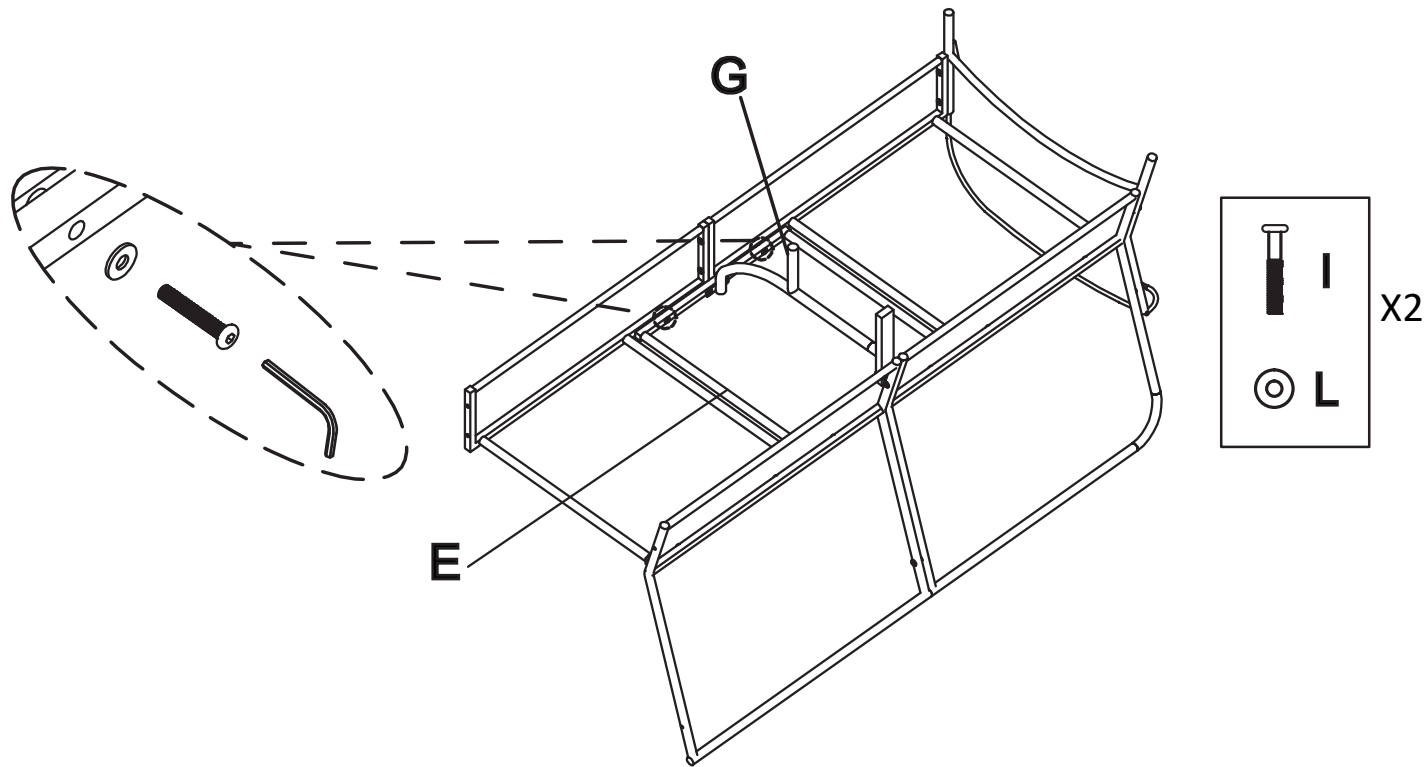

Step 8: Attach seat panels to back panels with 6pcs bolts I and 6pcs washers L, using Allen wrench N. Note: Don't fully tighten the bolts.

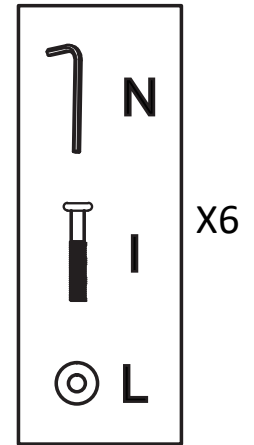
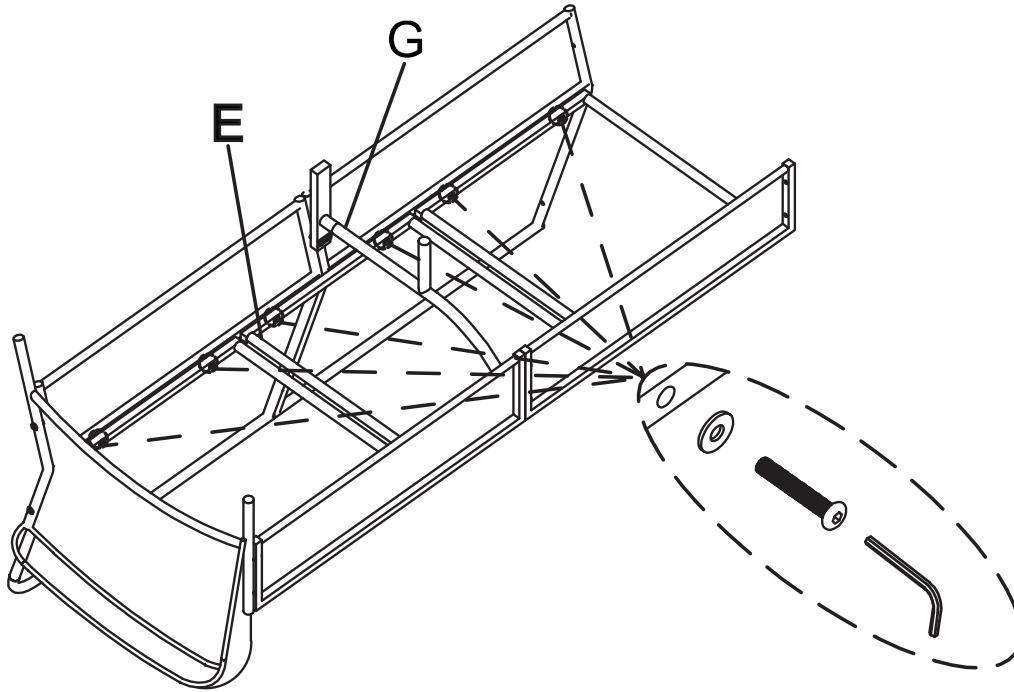

Step 9: Attach assembled right arm sofa back to left arm sofa back with 2pcs bolts K ,4pcs washer L and 2pcs nuts M by wrench O and Allen wrench N .Note: Don't fully tighten the bolts.

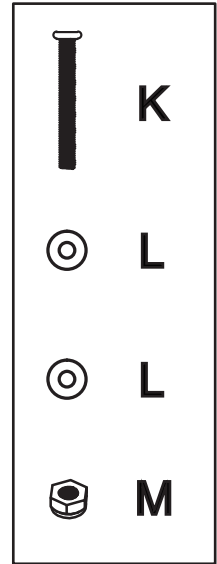
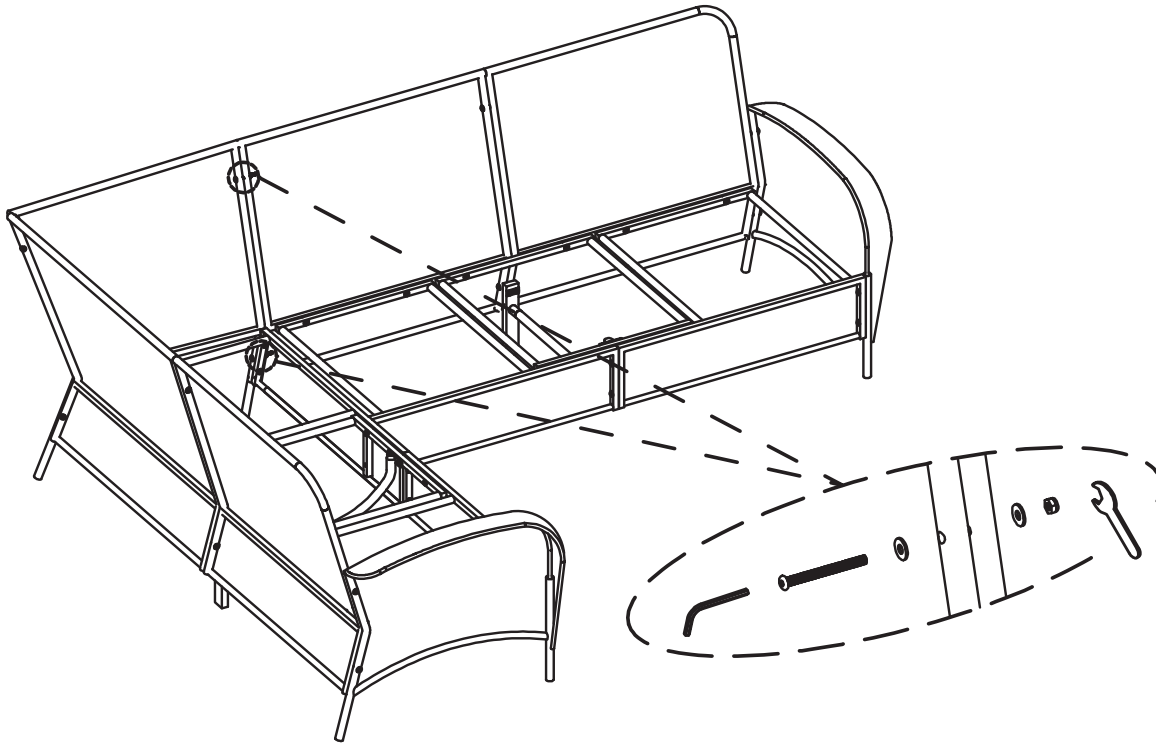

X2

Step 10: Attach assembled right arm sofa seat to left arm sofa seat with 2pcs bolts K ,4pcs washer L and 2pcs nuts M by wrench O and Allen wrench N .
Note:Please fully tighten the bolts.

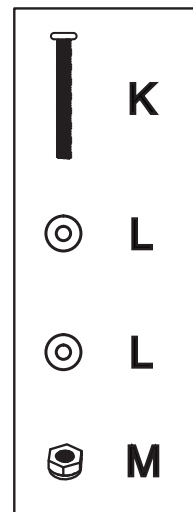
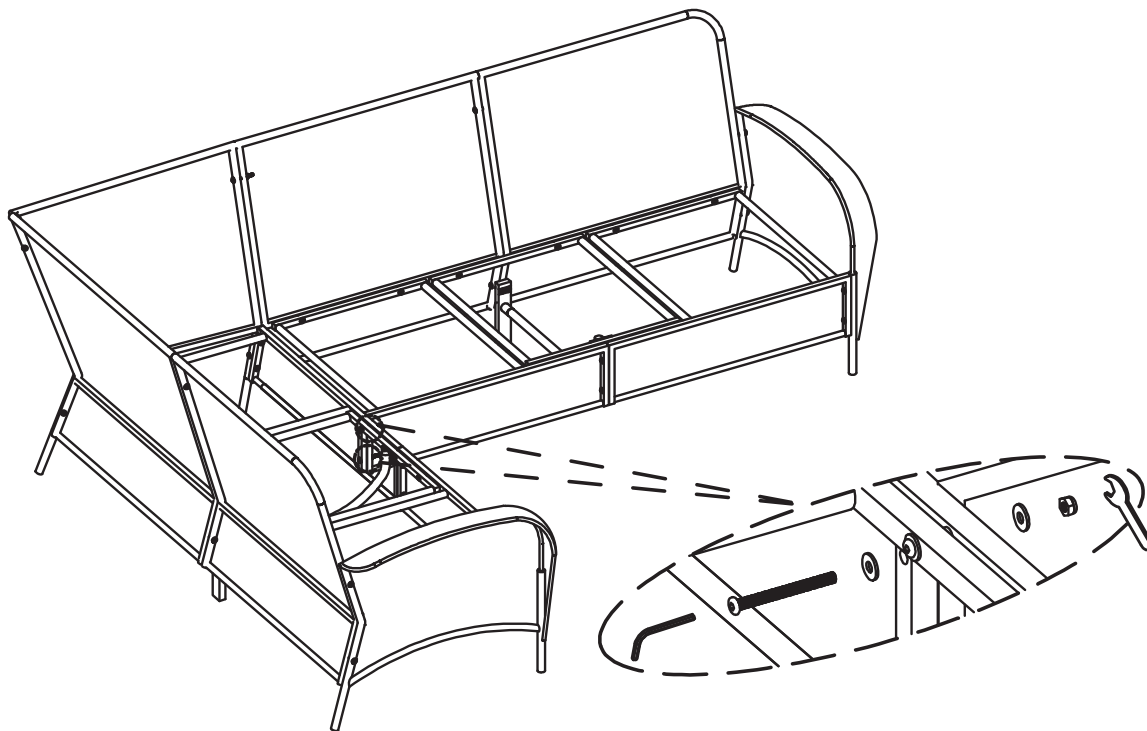

X2

Step 11: Put seat cushion Q and back cushion R onto the seat. Assembly is now complete and the product is ready for use.

