

Assembly Instructions

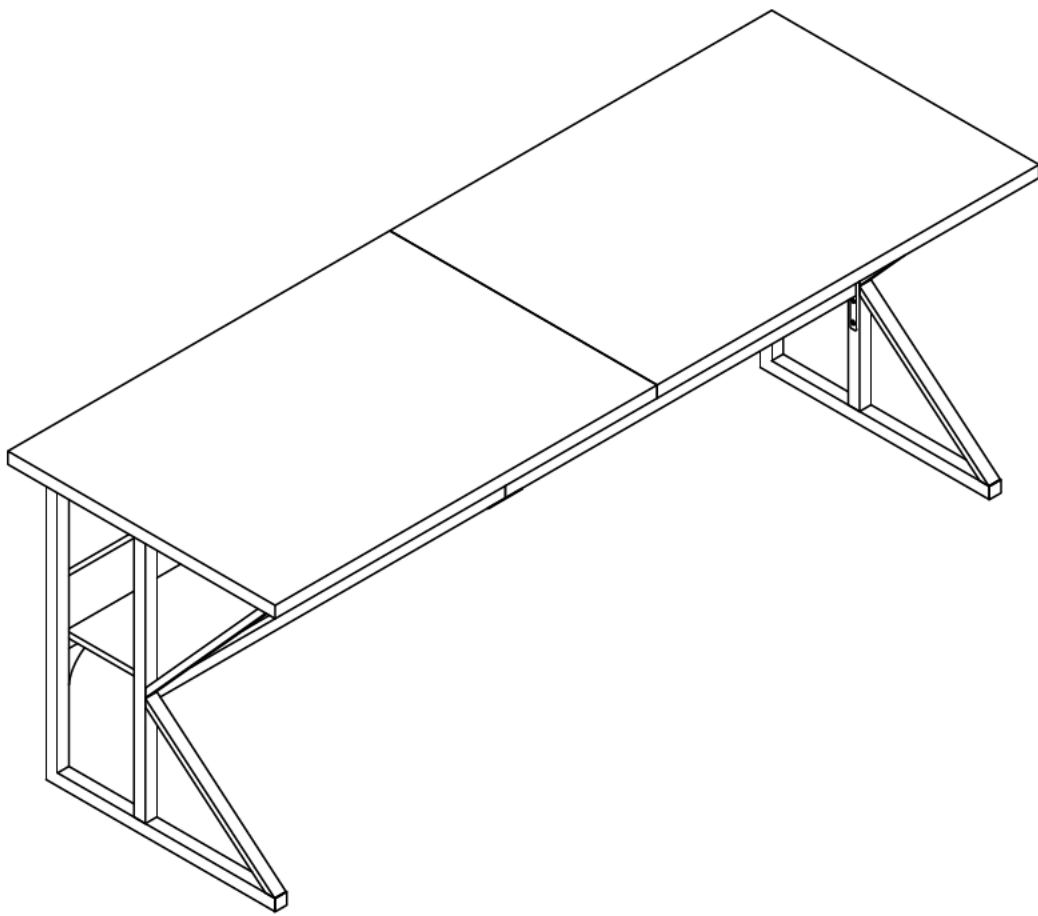

Multifunctional Computer Desk

Assembly Instructions:

1. Carefully read these instructions and keep them for future reference.
2. Refer to the parts list for guidance and ensure that you have all the pieces before starting the assembly process, if anything is missing, damaged, incorrect, contact us **FIRSTLY BEFORE** assembling.
3. When assembling, place all parts on a soft, clean, and flat surface, such as a carpet, to prevent any scratches.
4. To avoid misalignment of the holes, Please don't full tighten the screws until you ensure all parts in place.

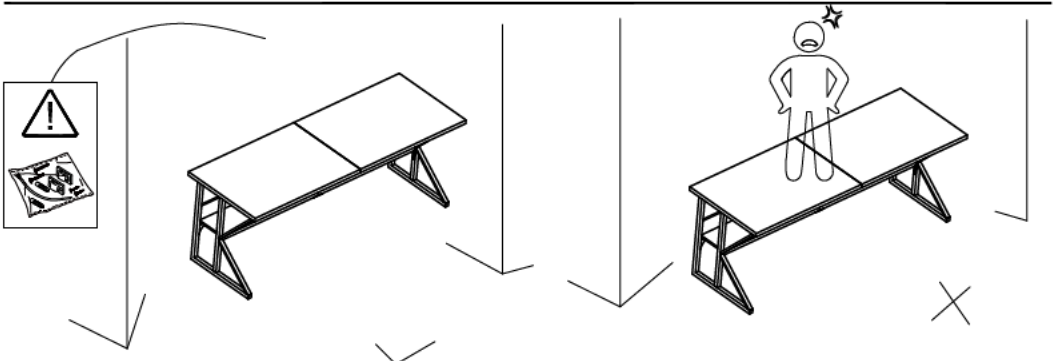
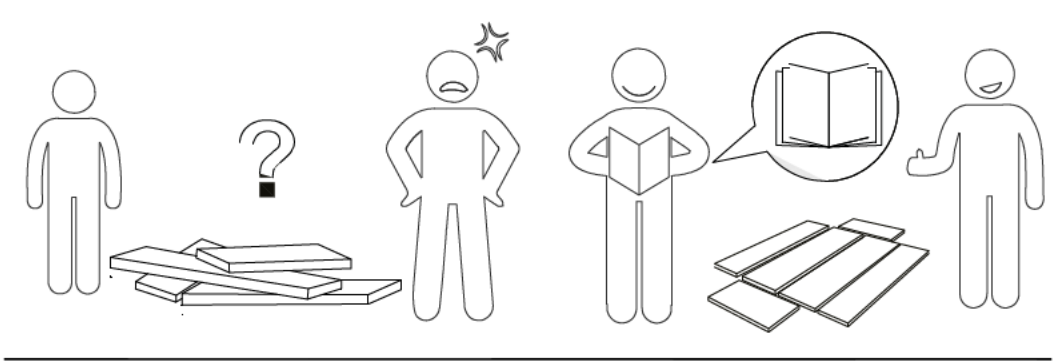
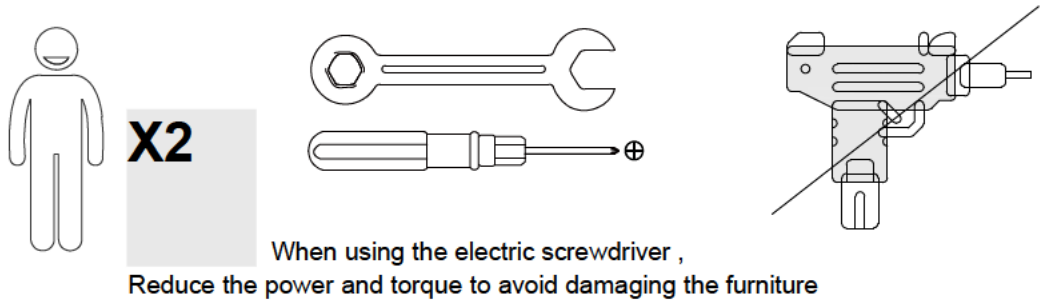

the risk of tip-over.

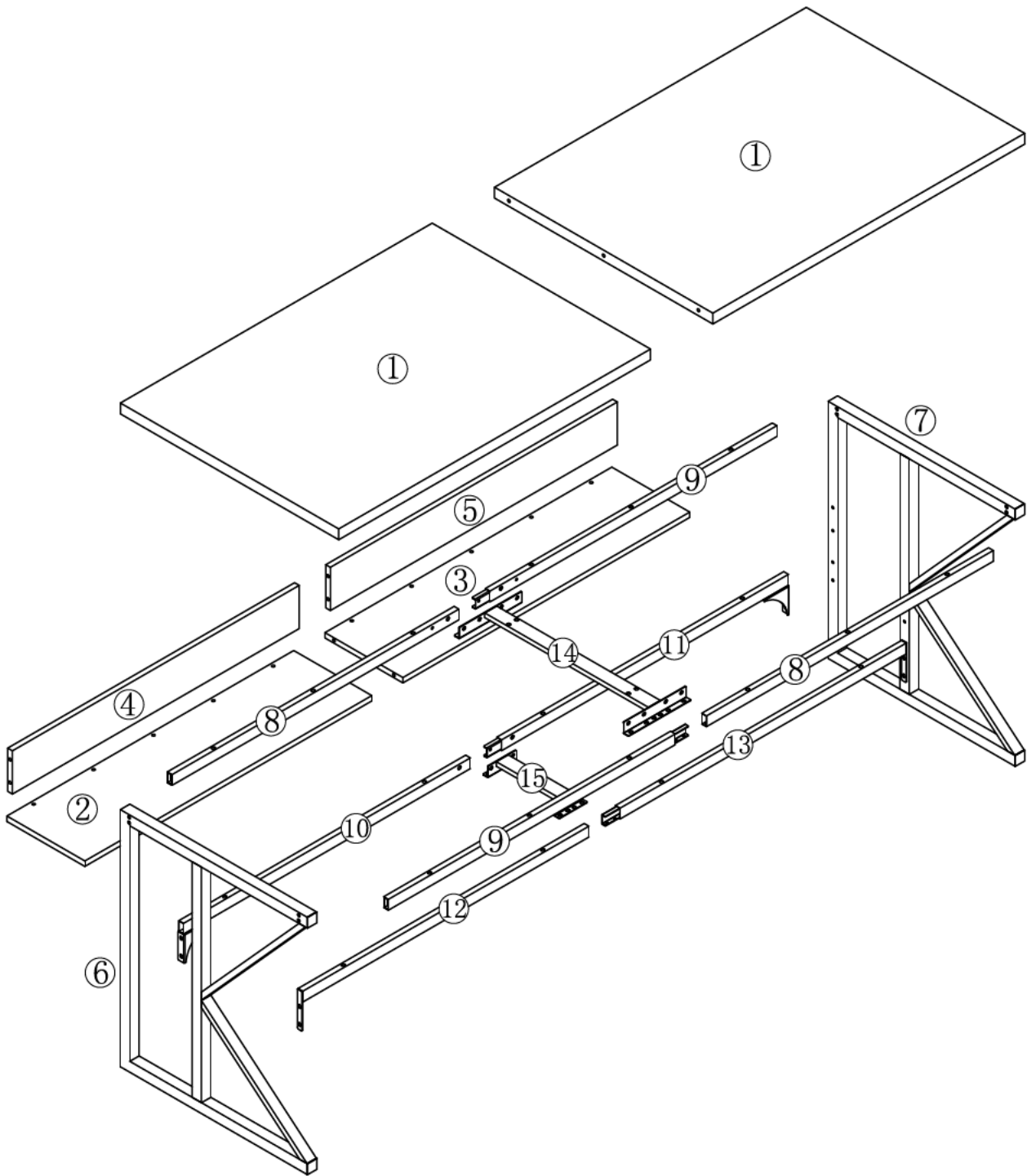

▲Caution

Make sure all parts are included. Most board parts are labeled or stamped on the raw edge.

Contact us for free replacement if having damaged or missing parts.

Parts & Hardware List

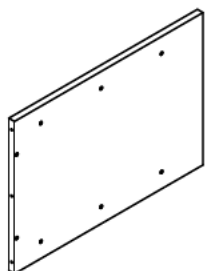

① 2PCS

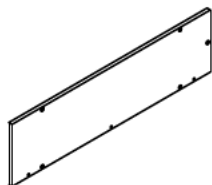

② 1PC

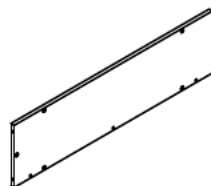

③ 1PC

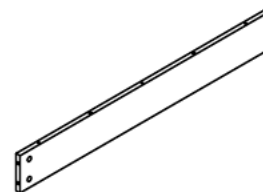

④ 1PC

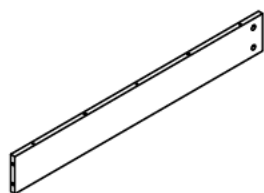

⑤ 1PC



⑥ 1PC

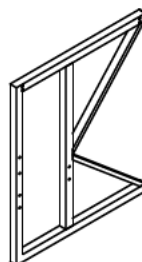

⑦ 1PC

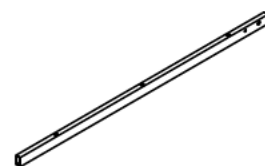

⑧ 2PCS

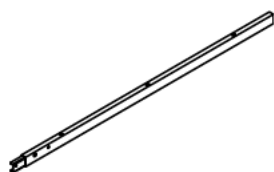

⑨ 2PCS

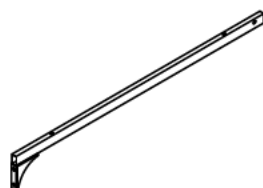

⑩ 1PC

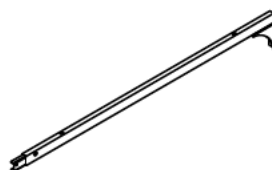

⑪ 1PC

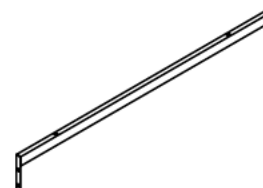

⑫ 1PC

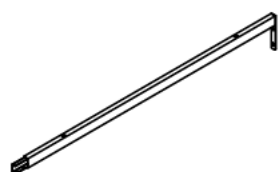



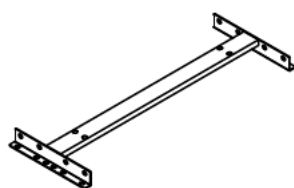



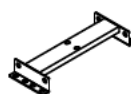



⑬ 1PC



⑭ 1PC



⑮ 1PC

<p>A</p>  <p>M6×12mm 40PCS</p>	<p>B</p>  <p>M6×22mm 6PCS</p>	<p>C</p>  <p>M6×40mm 20PCS</p>	<p>D</p>  <p>M6×50mm 8PCS</p>	<p>E</p>  <p>M7×50mm 6PCS</p>	<p>F</p>  <p>4PCS</p>
<p>G</p>  <p>4PCS</p>	<p>H</p>  <p>∅8×30mm 11PCS</p>	<p>I</p>  <p>4PCS</p>	<p>J</p>  <p>4mm 1PC</p>		

①

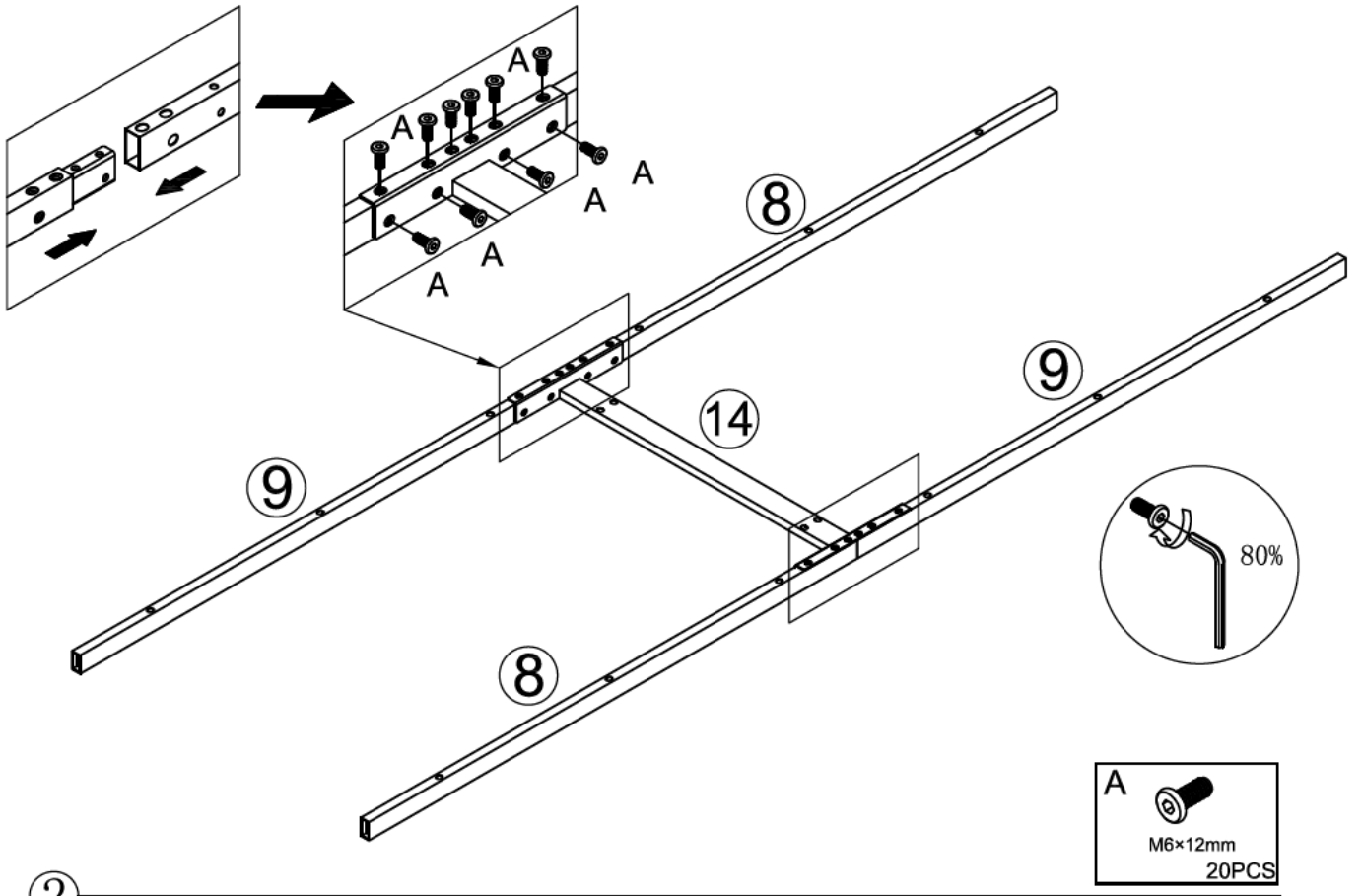

②

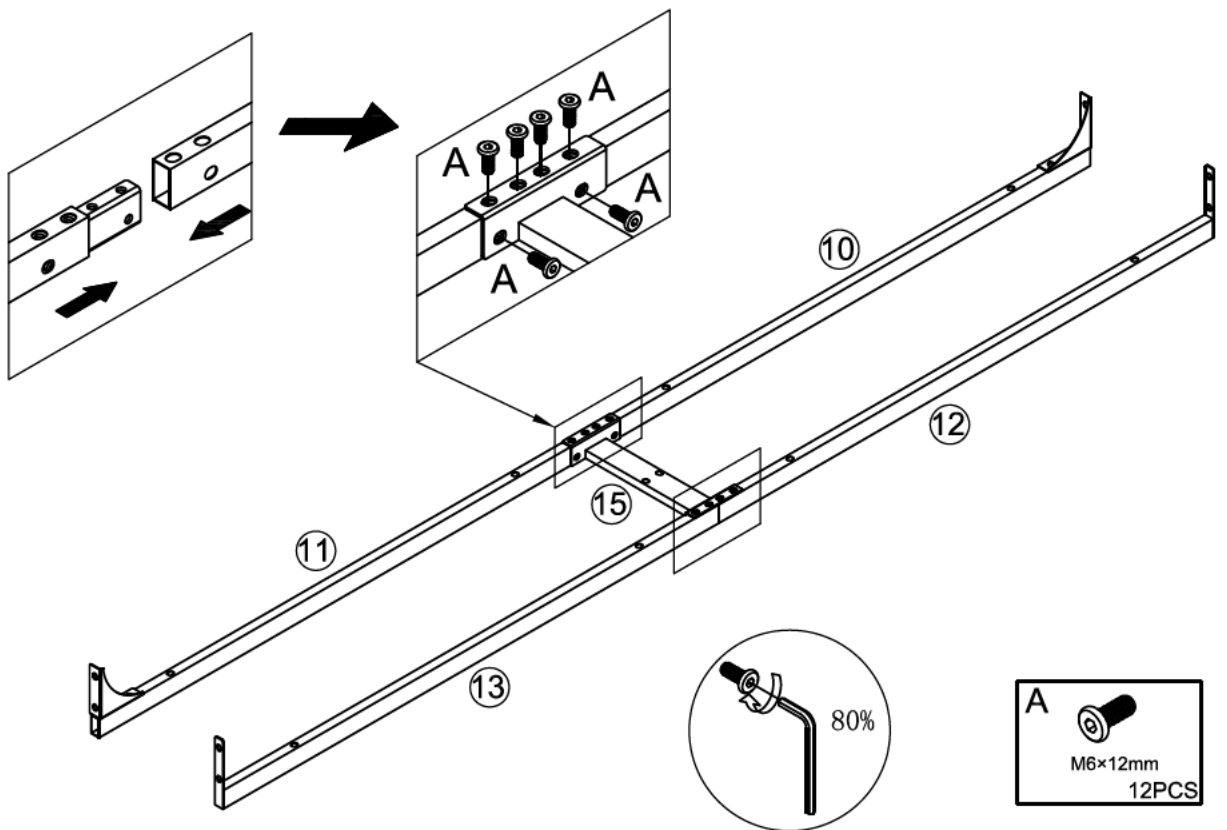

P-05

③

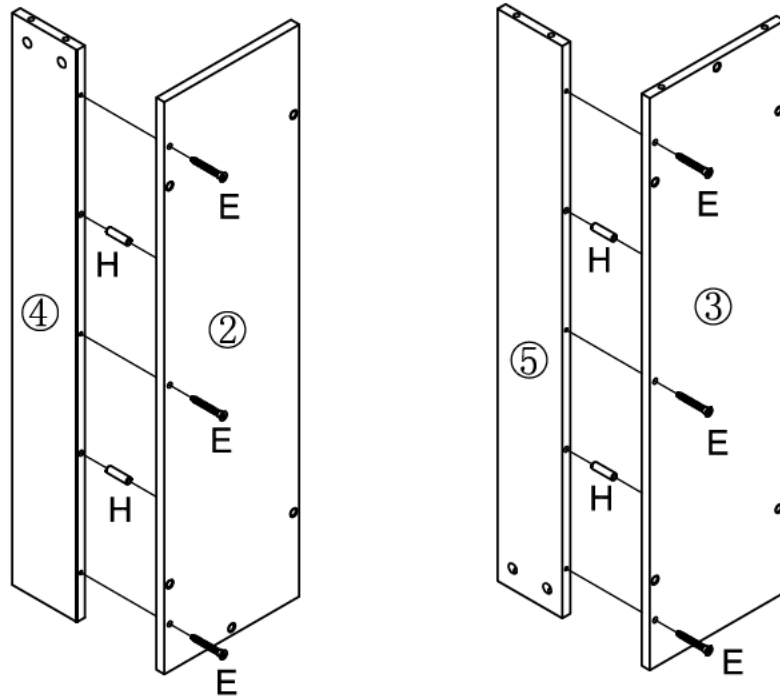

④

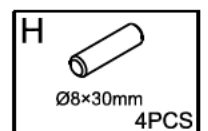
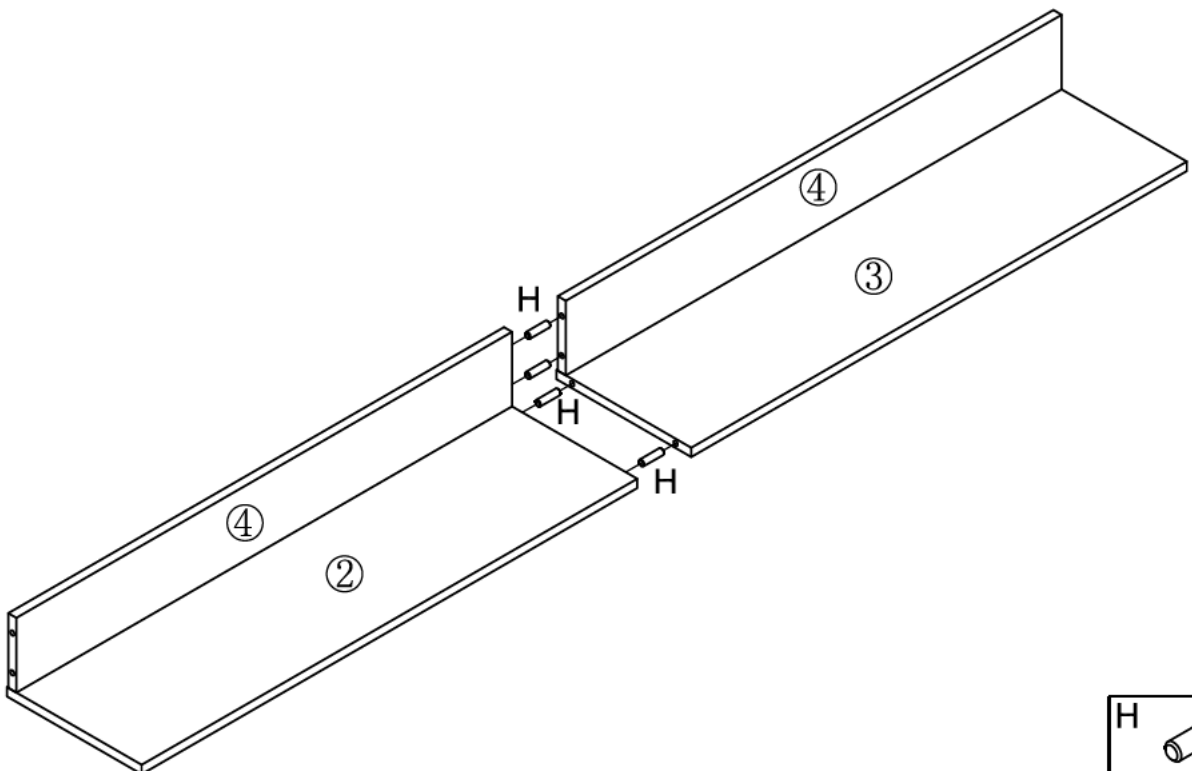

P-06

5

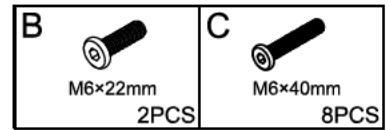
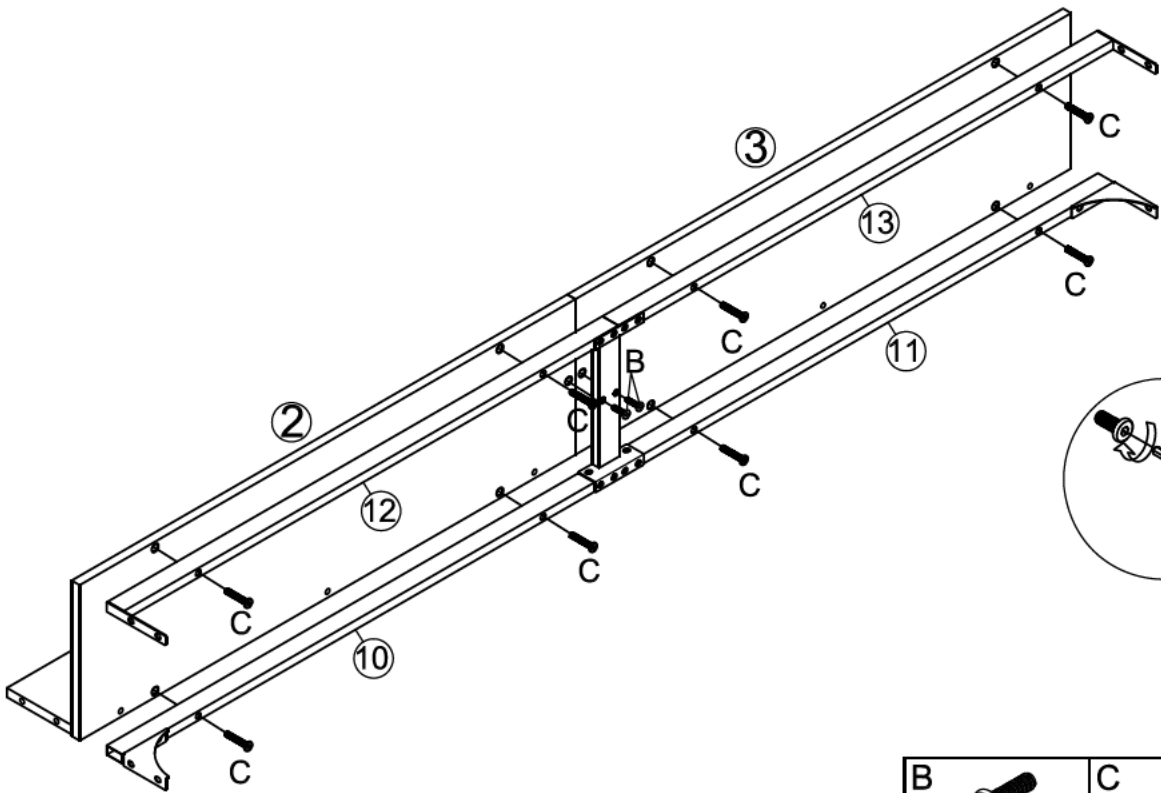

6

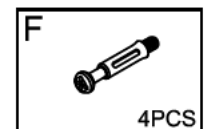
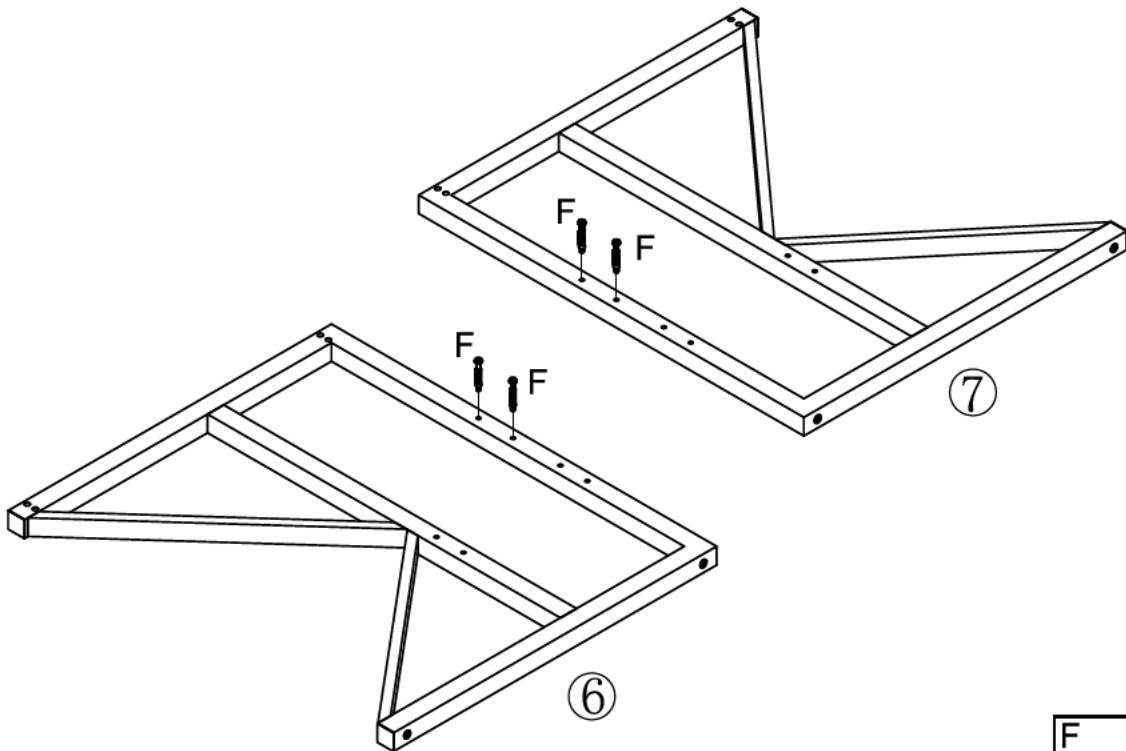

7

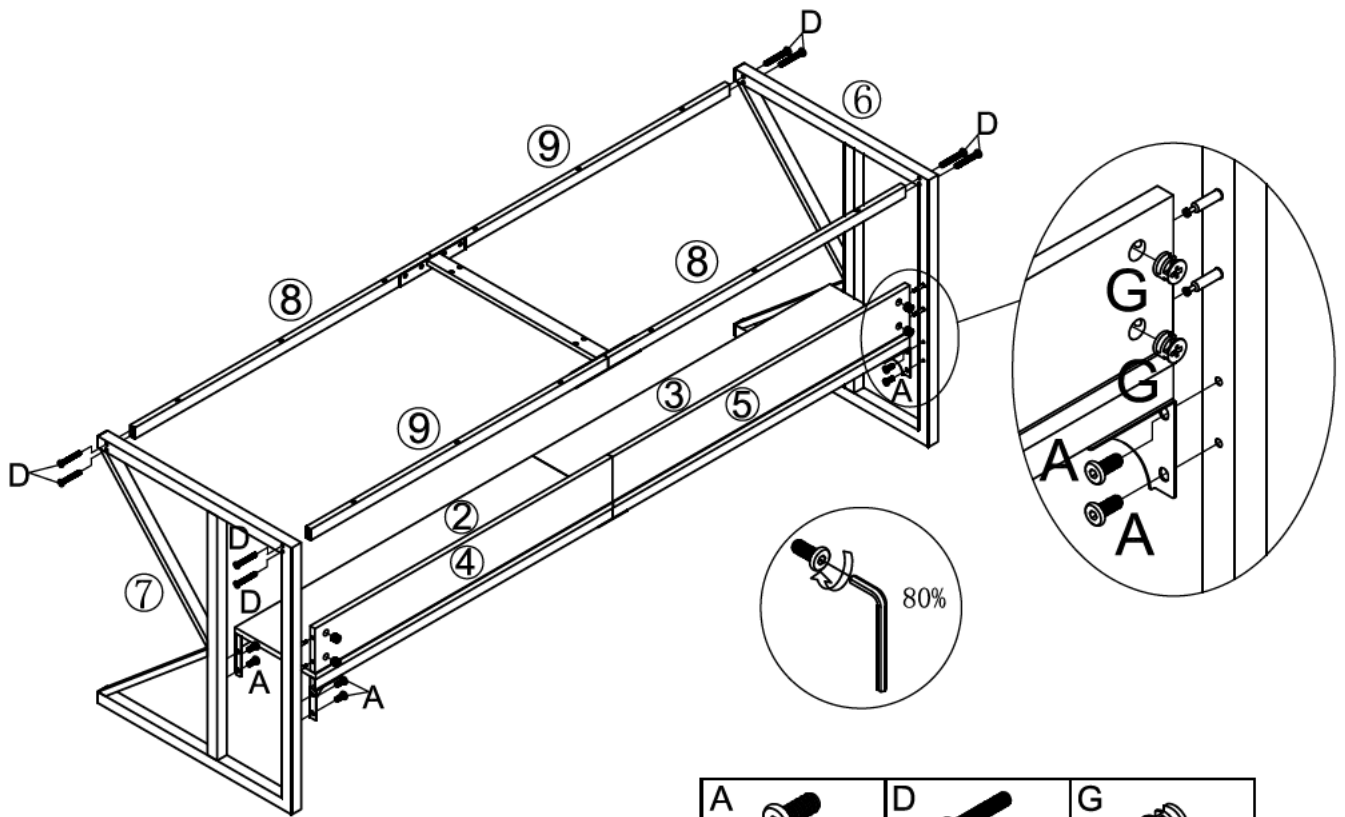

A M6×12mm 8PCS	D M6×50mm 8PCS	G 4PCS
----------------------	----------------------	-----------

8

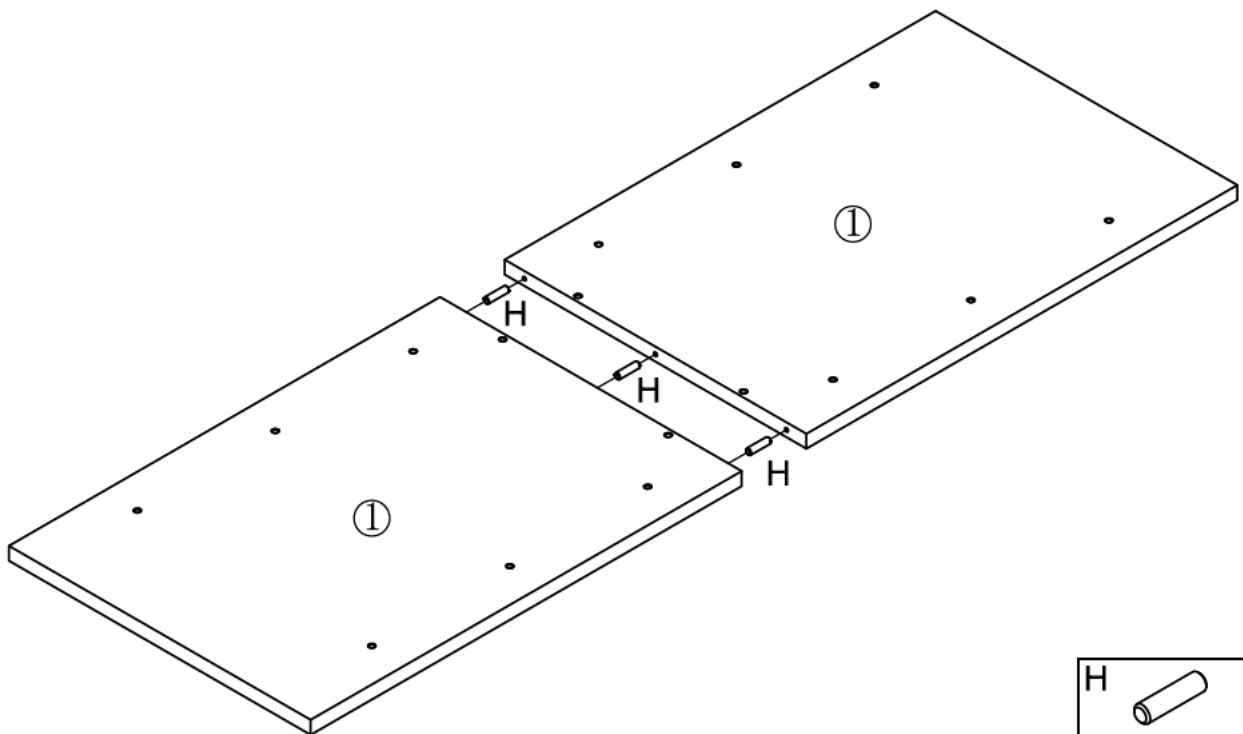

H Ø8×30mm 3PCS

9

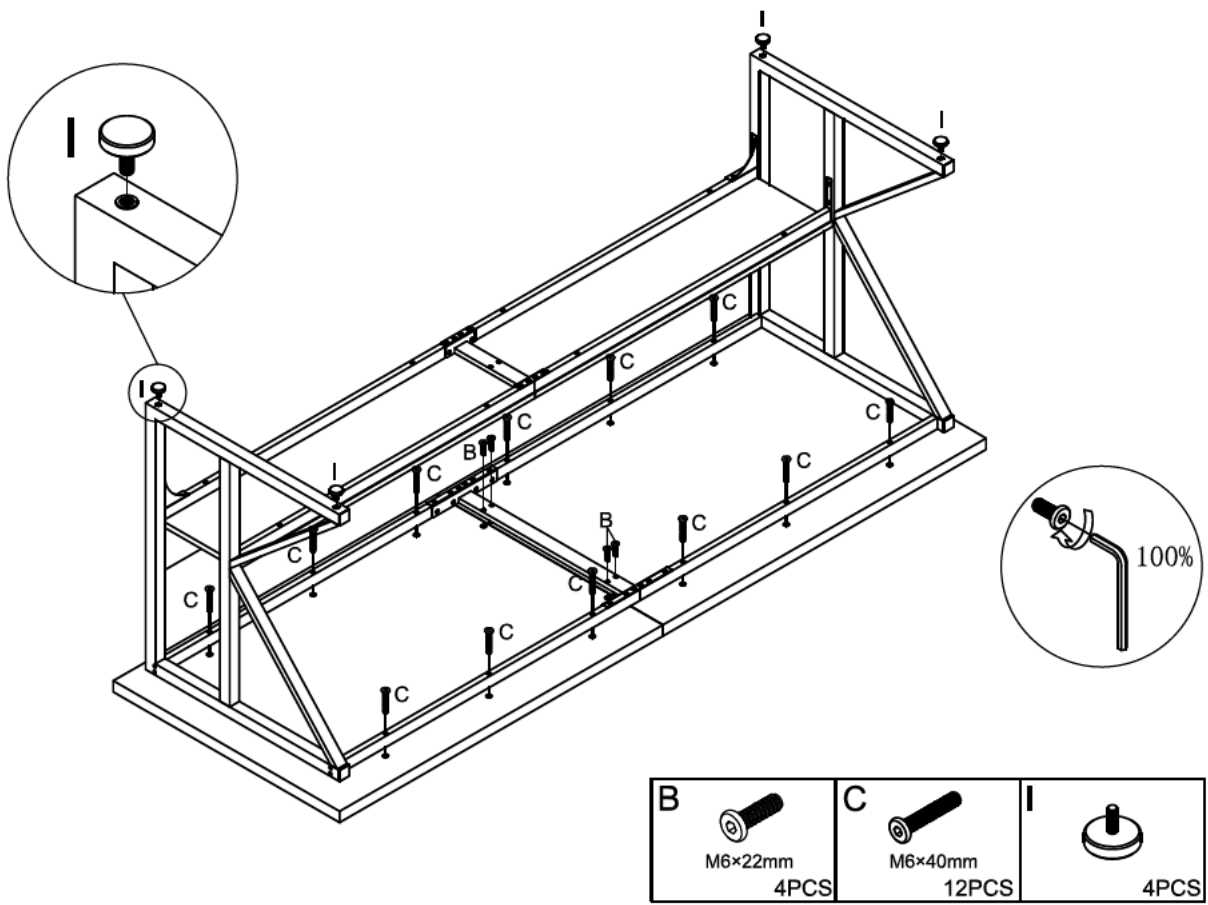

10

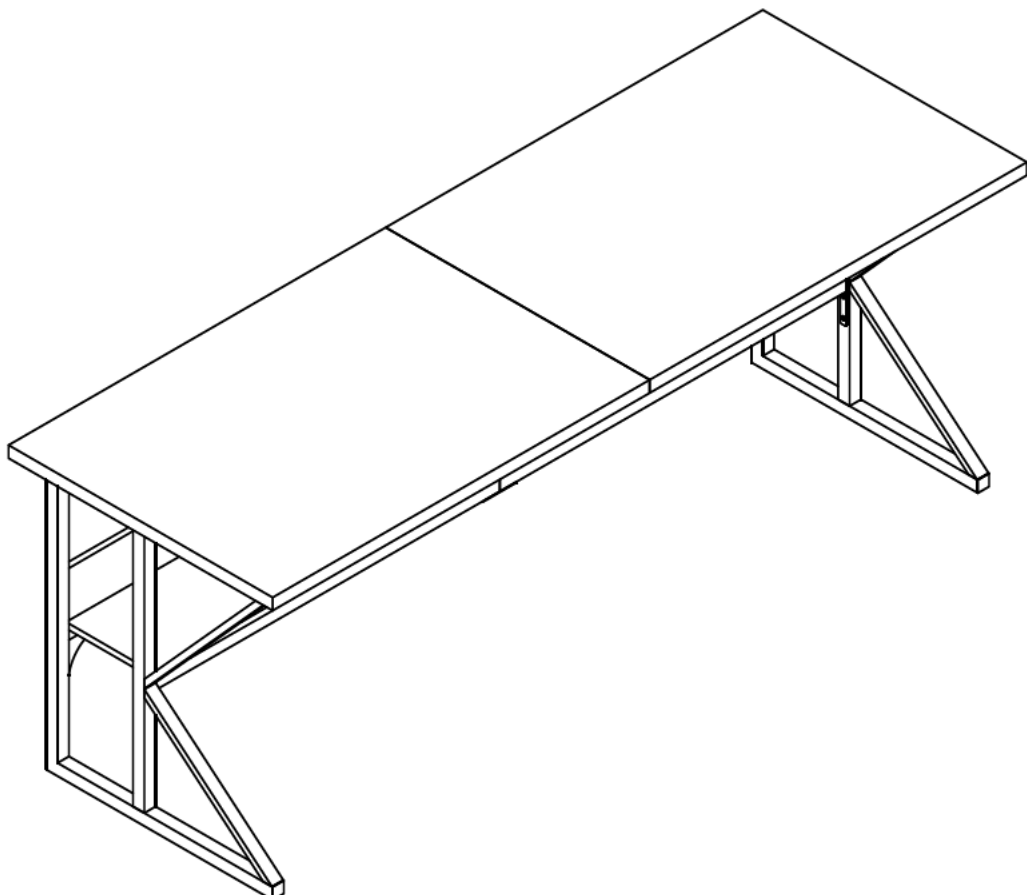

9

