

## ASSEMBLY INSTRUCTIONS

Minimum No.  
Of People  
Recommended  
To Assemble  
This Product :

**2**

Approximate  
Assembly  
Time :





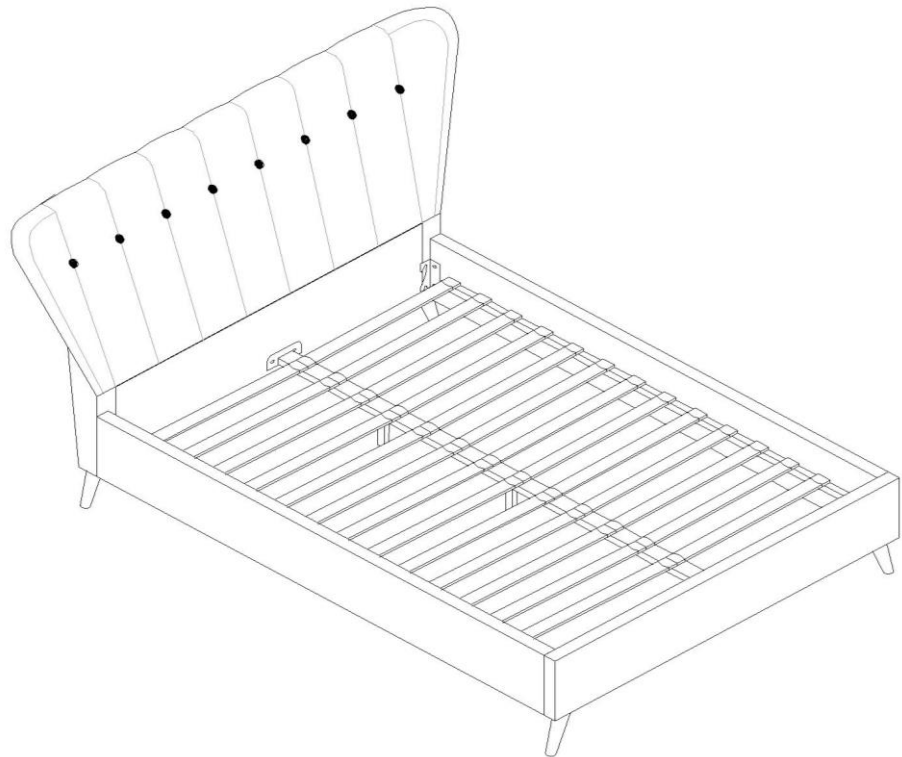

**30**



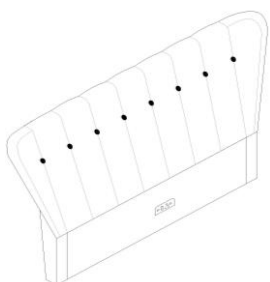
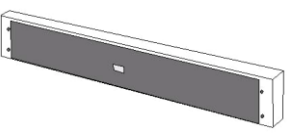

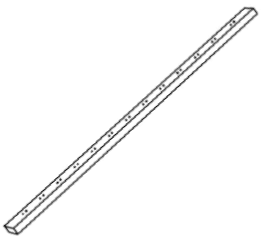

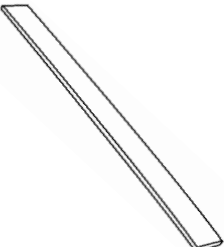

MINUTES

**BEFORE YOU  
START, HERE  
IS SOME  
HELPFUL  
ADVICE :**

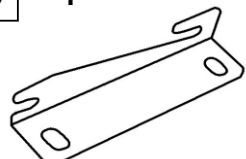
1. We suggest you spend a short time reading through this leaflet and then follow the simple step by step instructions.
2. If you follow the instructions carefully, the end result should be worth the effort.
3. Do not discard any of the packaging until you have checked that you have all the parts and the pack of fittings.
4. This product is more stable when assembled and placed on carpet.
5. To ensure an easier assembly, we strongly advise that all fittings are only finger-tightened during initial assembly phase. Only upon completion of the assembly should all fixing points be fully tightened.
6. We recommend a periodic check on all fixing points to make sure they remain fully tightened.
7. Keep any fittings out of children's reach.

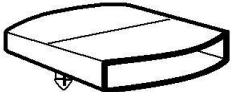
PARTS AND HARDWARE LISTS

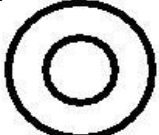
<p><b>1</b> x1pc Headboard</p> 	<p><b>2</b> x1pc Footboard</p> 	<p><b>3</b> x2pcs Siderail</p> 	<p><b>4</b> x2pcs Support Leg</p> 
<p><b>5</b> x1pc Central Rail</p> 	<p><b>6</b> x4pcs Wooden Leg</p> 	<p><b>7</b> x30pcs Flat Slat</p> 	<p><b>8</b> x1pc Across Bar</p> 

<p><b>A</b> x1pc</p> 	<p><b>B</b> x24pcs</p>  <p>M8x25mm</p>	<p><b>C</b> x2pcs</p>  <p>M8x40mm</p>
<p><b>D</b> x4pcs</p> 	<p><b>E</b> x2pcs</p>  <p>M6x20mm</p>	<p><b>F</b> x2pcs</p> 
<p><b>G</b> x15pcs</p> 	<p><b>H</b> x30pcs</p> 	<p><b>I</b> x2pcs</p>  <p>M6x60mm</p>
<p><b>J</b> x2pcs</p> 	<p><b>K</b> x2pcs</p> 	<p><b>M</b> x1pc</p> <p>smaller</p> 

**STEP 1** Fix the *Wooden Legs (6)* to the bottom of the *Headboard (1)* and *Footboard (2)*

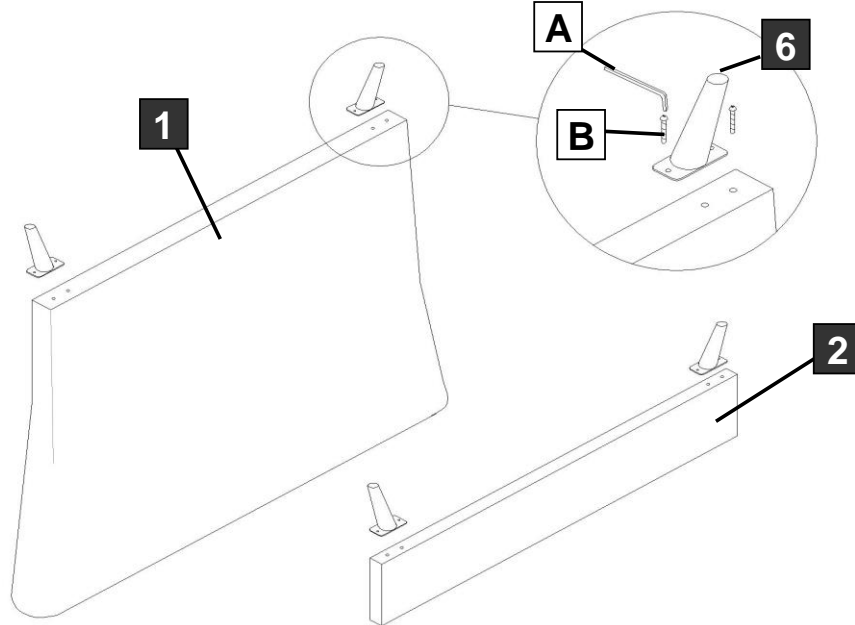

**STEP 2** Attach the *Bracket (D)* with *Screw (B)* and slightly tighten with *Allen Key (A)*. Mount both *Siderails (3)* to *Headboard (1)* and *Footboard (2)* by pushing the *Bracket (D)* down to fit. Do not fully tighten the screws at this moment.

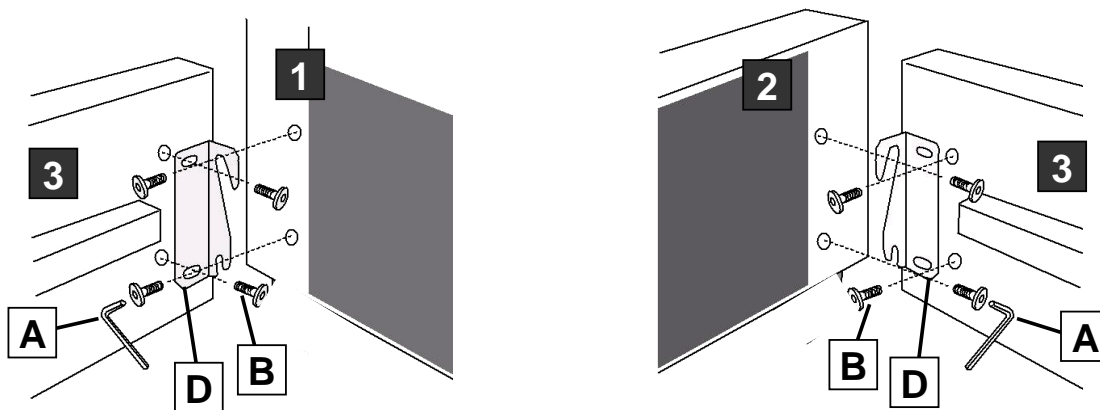

**STEP 3** Attach the *Support Legs (4)* to the *Central Rail (5)* with *Screw (C)* and tighten with the *Allen Key (A)*.

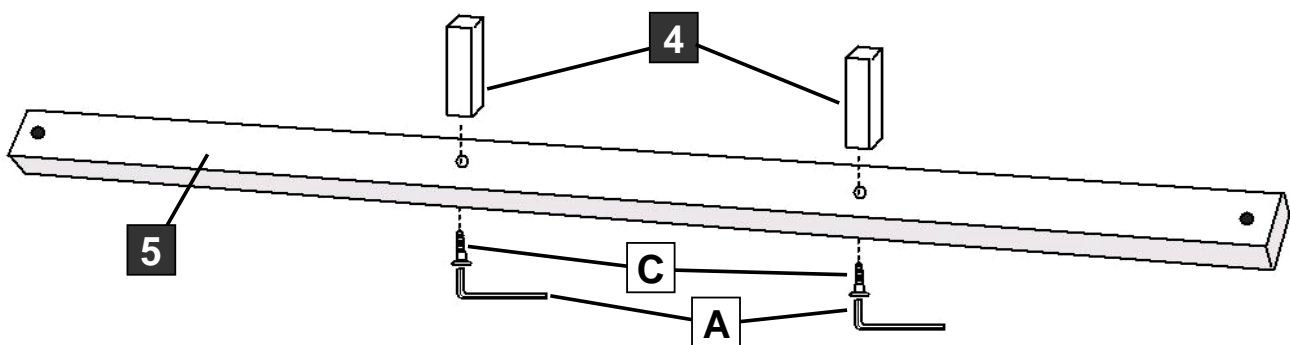

**STEP 4**

Attach the *Central Rail (5)* to the *Headboard (1)* and *Footboard (2)* with *Screw (E)* and *Bracket (F)*

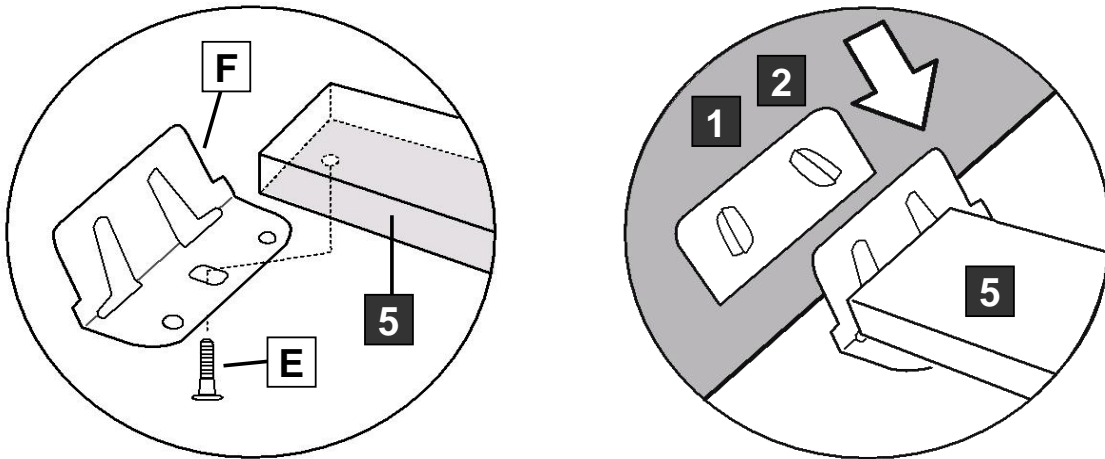
**STEP 5**

Attach *Across Bar (8)* to the bottom of the *Sideral shelf (3)* using *Screw (I)*, *Washer (J)* and *Hex Nut (K)* with the *smaller Allen Key (M)*.

Insert the *Flat Slats (7)* to both ends of slat *Middle Holder (G)* before attaching slat *End Holder (H)* to the other end of *Flat Slats*. Having done this, press down the *Middle Holder (G)* and the *End Holder (H)* to the siderail shelf and *Central Rail*. Repeat the above all the way down the bed.

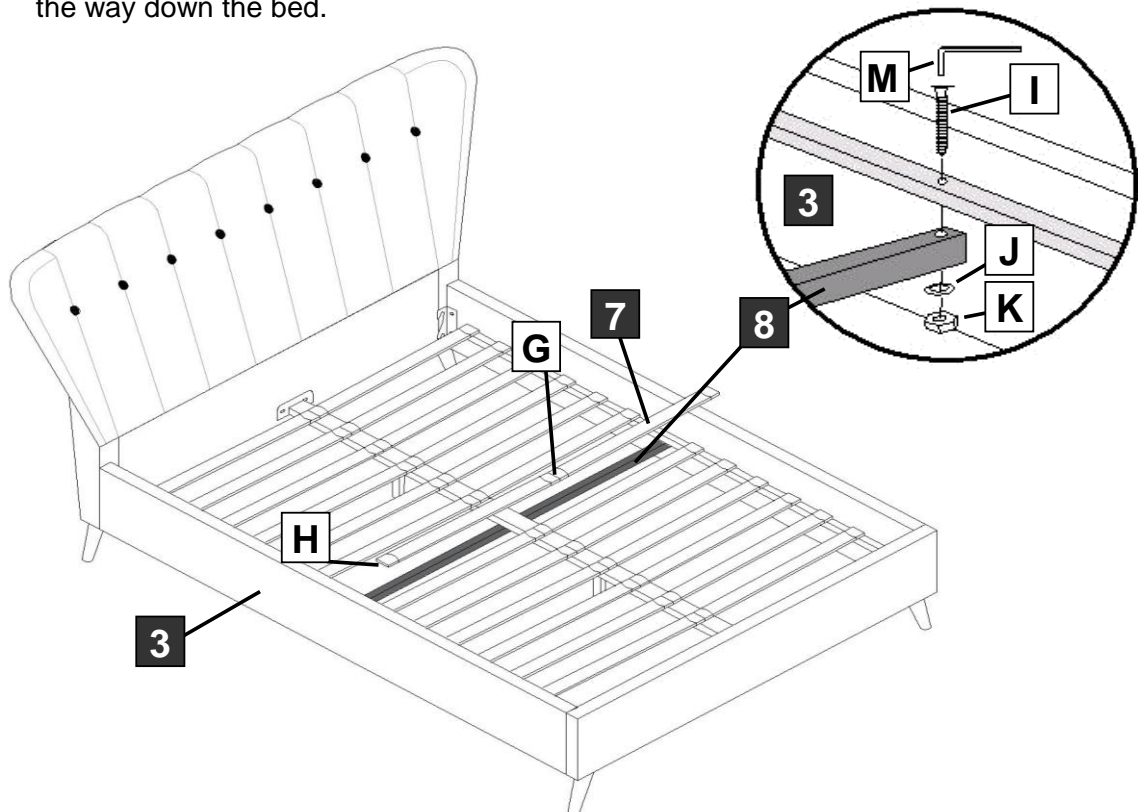

## **PROBLEMS?**

SHOULD YOU ENCOUNTER ANY DIFFICULTY WITH THE  
ASSEMBLY OF YOUR BED, PLEASE DO NOT TROUBLE  
YOUR RETAILER BUT  
CALL, FAX, E-MAIL or WRITE to our  
**CUSTOMER SERVICES DEPARTMENT**  
BETWEEN THE HOURS OF  
9.00am to 5.00pm MONDAY to THURSDAY  
and  
9.00am to 4.00pm FRIDAY

Tel : 01455 850 150

Fax: 01455 848 169

Email: [info@limelightbeds.co.uk](mailto:info@limelightbeds.co.uk)

Limelight Beds Ltd  
Orbital House  
Arthur Street  
Barwell  
Leicestershire  
LE9 8GZ

Please have the following information ready for our staff

- Product Name
- Part Number

see our range on website:  
[www.limelightbeds.co.uk](http://www.limelightbeds.co.uk)

## CARING FOR YOUR NEW LIMELIGHT PRODUCT

- **PLEASE NOTE:** GOODS THAT NEED TO BE RETURNED SHOULD BE SENT BACK IN ITS ORIGINAL PACKAGING.
- When assembling your bed, please ensure that you have checked the contents for all relevant parts.
- When tightening bolts, do make sure that they are fully tightened but not forced.
- When moving your fully assembled bed, you must first remove the mattress and lift the frame into position; taking care when lifting and always have two people handling the bed. **PLEASE DO NOT DRAG THE BED** as this will cause damage to the central support legs and rail. Central legs **MUST** be in a vertical position at all times.
- Due to the nature of laminate flooring, we recommend that you place non-slip material under the central support legs. This will stop the legs from sliding on laminate/wooden floors and will prevent the bed from collapsing.
- It is advisable to use approved cleaning products when cleaning the furniture and bed frame as certain chemical-based cleaners could have an adverse effect on the bed's finish.
- All Limelight beds are produced to the highest standards and are packed to avoid damage in transit. Should you find that your new bed does not meet your satisfaction, please contact Limelight's Customer Services Department at 01455 850 150.