

INSTRUCTION
ANWEISUNG

取扱説明書

60cm

INSTRUCTION
사용설명서



*Two people for assembly

*Installieren zwei
Personen zusammen

*2人作業が必要です

*Two more accessories for B and C will be provided.

*B und C Ersatzteile geben extra zwei Stück

*部品Bも部品Cも2つのスペアが同梱されています

*부품B,C는 비품이 2개씩 더 준비해두겠습니다

*Vous aurez 2 en plus de pièce B, C comme rechange.

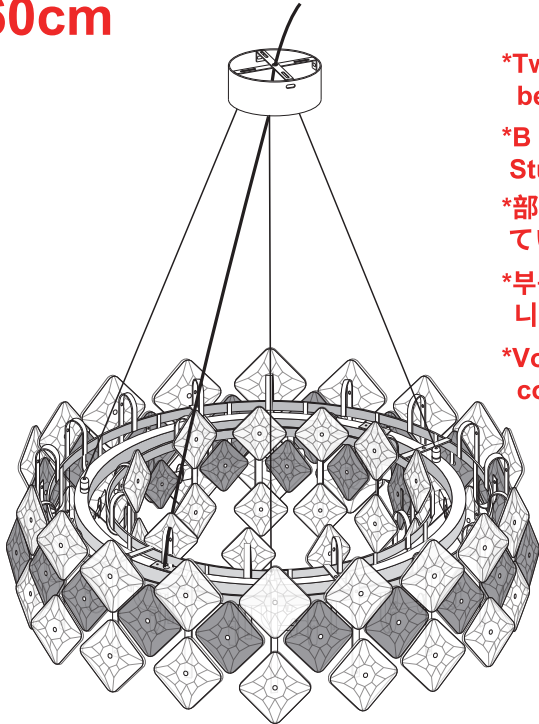

A *1

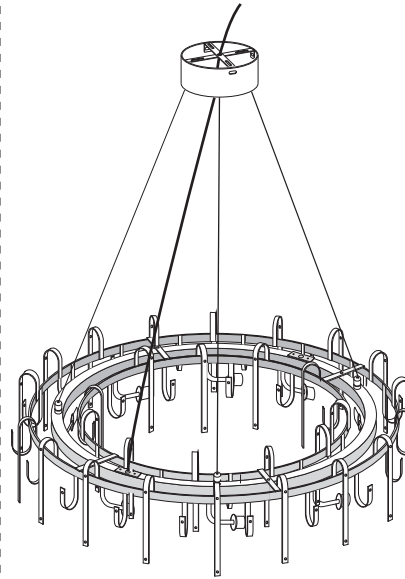

B *29

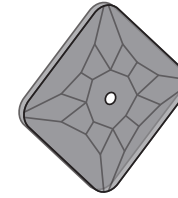

C *58

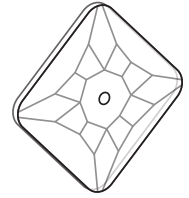

D *6

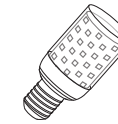

E *4

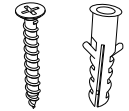

F *87



G *87



H *87

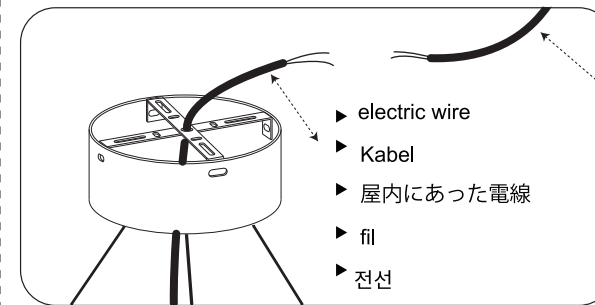

- ▶ electric wire
- ▶ Kabel
- ▶ 屋内にあった電線
- ▶ fil
- ▶ 전선

- ▶ reserved wire in the house
- ▶ Haushalt reservierter Kabel
- ▶ 屋内にあった電線
- ▶ fil réservé
- ▶ 가정용 예비 전선

1. Please check the lamps lighting and accessories after unboxing, contact us if there is any issue.
- 1.Bitte überprüfen Sie vor der Installation, ob die richtige Anzahl von Zubehörteilen vorhanden ist. Testen Sie die Lampe nach der Installation und wenden Sie sich an den Verkäufer, wenn die Lampe nicht aufleuchtet.
- 1、開梱した後、まずすべての部品の数量を確認してください。次、ライトを取り付けて、点灯できるかどうかテストしてください。万が一、不良がありましたら、販売者にご連絡ください。
- 1.Après le déballage, veuillez vérifier si le nombre d'accessoires est correct. Installez les ampoules et les allumez, si une ampoule ne s'allume pas, n'hésitez pas à nous contacter.
- 1, 포장을 풀고 먼저 모든 부품의 수량을 확인하시기 바랍니다. 다음 표시등을 설치하고 켜질 수 있는지 테스트하십시오. 만일, 불량 이 있으면, 판매자에게 연락해 주세요.

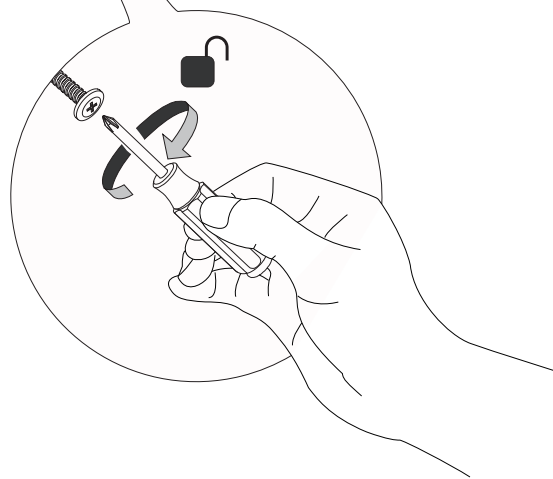
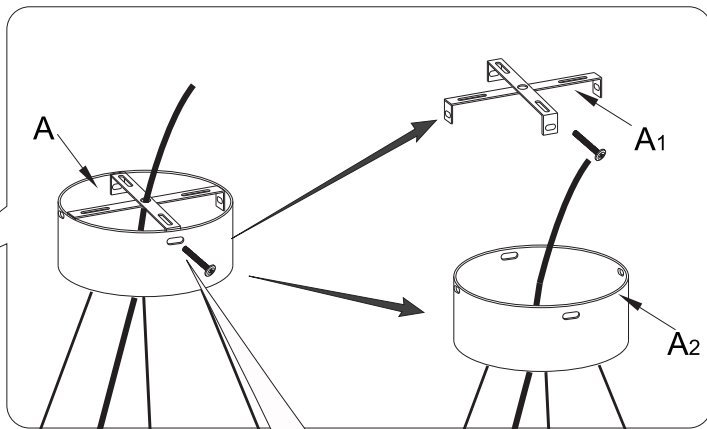

1

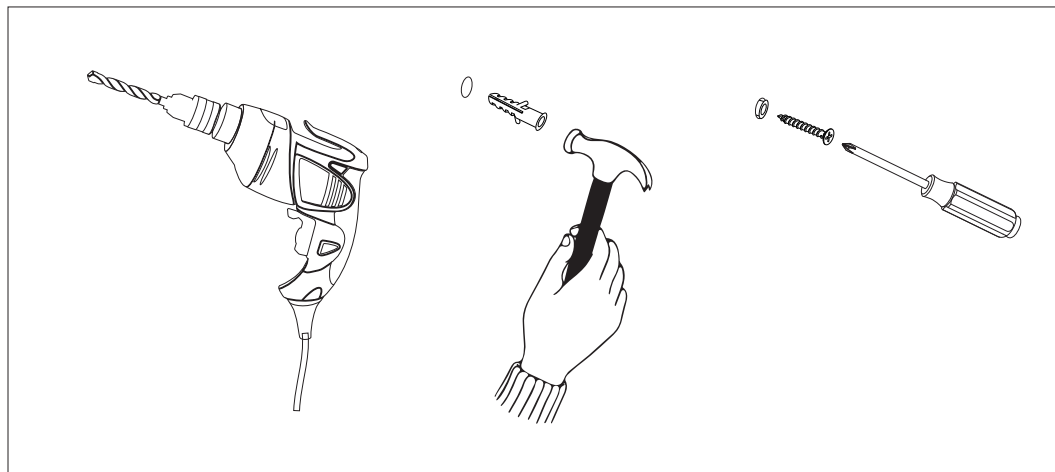
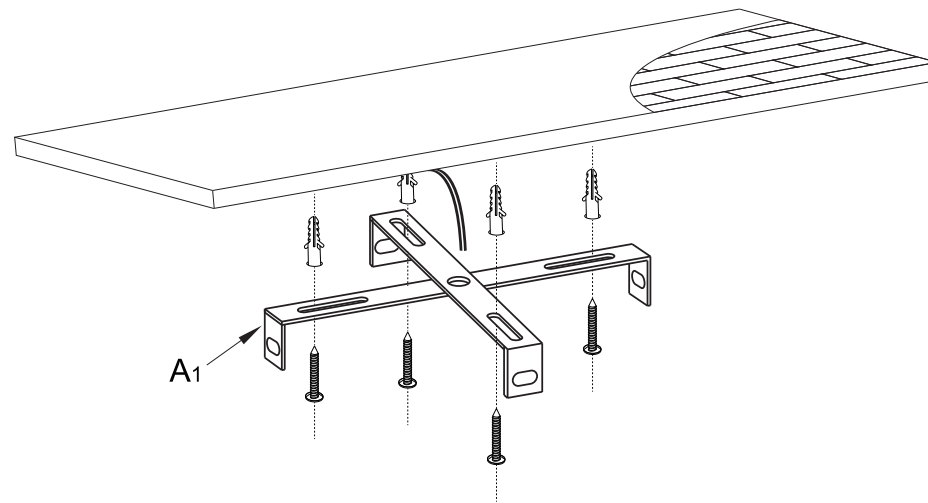

- ▶ Detach the ' Part A' as shown first
Drill the hole in the wall, hammer the A1 screw into the hole
- ▶ Teilen Sie bitte zuerst das „Zubehör A“ wie abgebildet, stanzen Sie ein Loch in die Wand und hämmern Sie die „Schraube A1“ in das Loch
- ▶ 上図のように、部品Aを分解してください。
天井に穴を開けてから、A1を穴に差し入れてください。
- ▶ Tout d'abord, séparez la "Partie A" comme indiqué.
Percez un trou dans le mur et enfoncez la "vis A1" dans le trou.
- ▶ 먼저 "부품 A"를 그림과 같이 분리하십시오.
벽에 구멍을 뚫어 "나사 A1"을 구멍에 박아 주십시오.

2

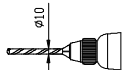
 E *4

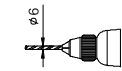
- | | | | | | |
|---|--|--------------------------|--------------|------------------|--------|
| 
70mm | 
φ10 | ▶ Brick wall | ▶ Ziegelwand | ▶ Mur de briques | ▶ 시멘트벽 |
| | | ▶ 콘크리트벽: 10mm径のドリルビットを使う | | | |
| 
60mm | 
φ6 | ▶ Wood wall | ▶ Holzwandl | ▶ Mur de bois | ▶ 나무벽 |
| | | ▶ 木柱壁: 6mm径のドリルビットを使う | | | |

3

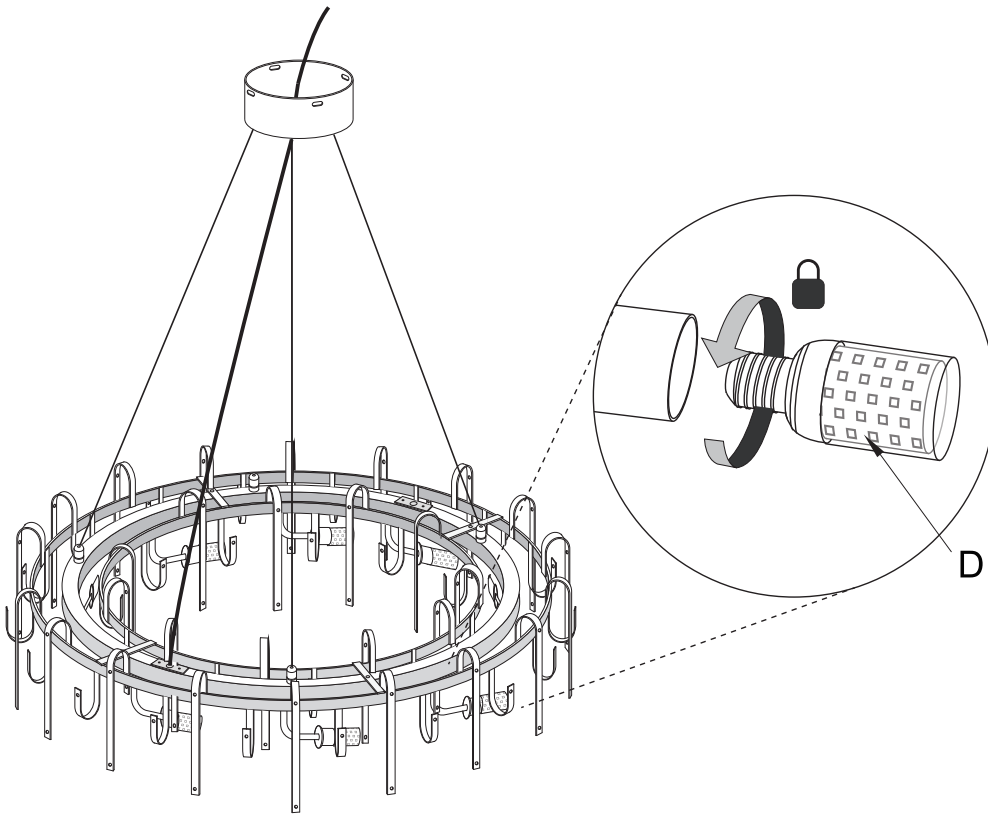

4

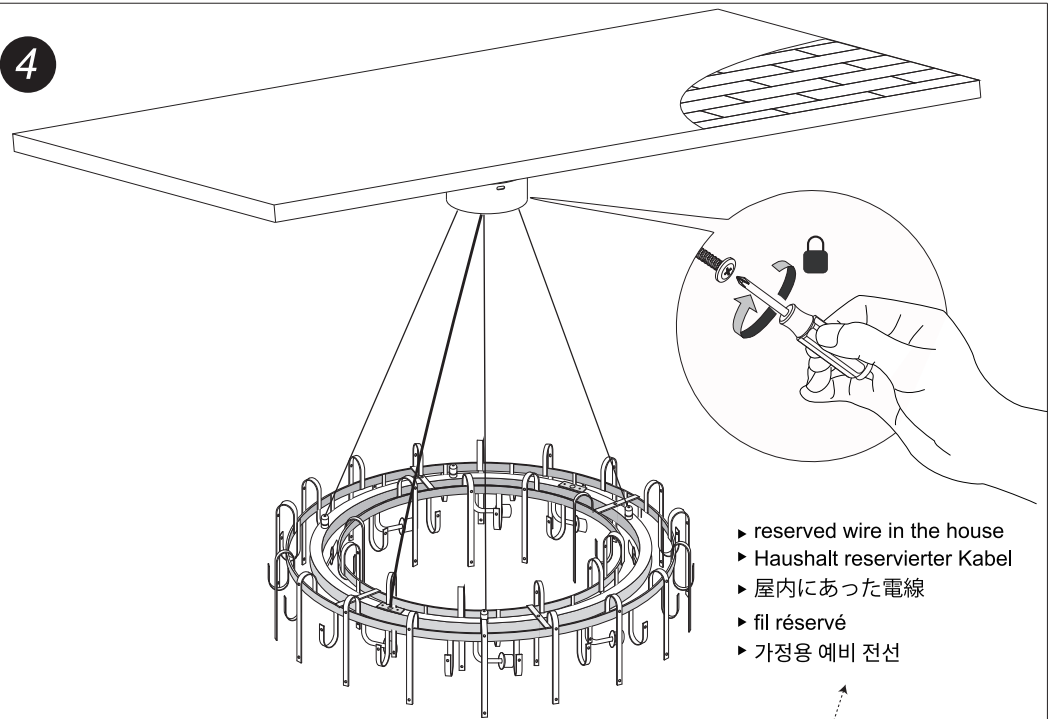

- ▶ reserved wire in the house
- ▶ Haushalt reservierter Kabel
- ▶ 屋内にあった電線
- ▶ fil réservé
- ▶ 가정용 예비 전선

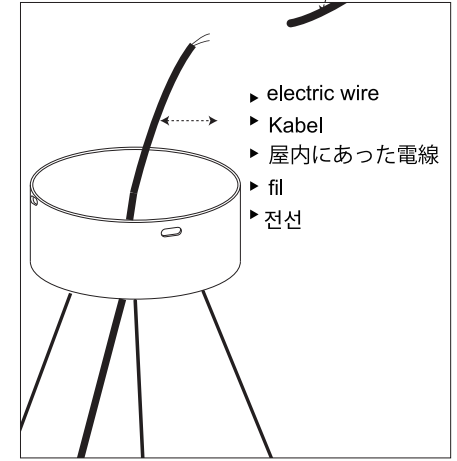
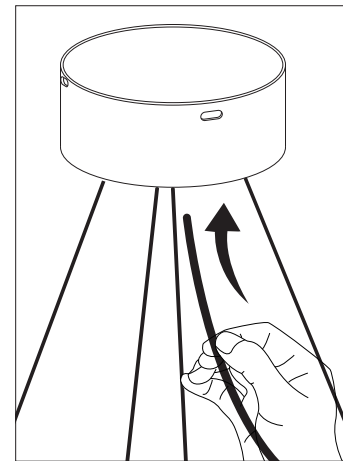

- ▶ electric wire
- ▶ Kabel
- ▶ 屋内にあった電線
- ▶ fil
- ▶ 전선

- ▶ Electric wire run through the Part A, connected with the wire in the house
- ▶ Das Kabel wird durch das E-Loch des Zubehörs geführt und mit dem für den Haushalt reservierten Kabel verbunden
- ▶ 照明の電源コードを配件Aに通してから、屋内にあった電線に繋がります
- ▶ Passez le fil par le trou de la pièce A et le connectez au fil réservé.
- ▶ 전선은 부속품 A의 구멍으로 통과하여 집에 남겨둔 전선과 연결됩니다.

5

F *87	G *87	H *87
