



New Orleans Style Awning (5'-20')

OWNER'S MANUAL & INSTALLATION INSTRUCTIONS

⚠ Warning: Adult Assembly Required; Kit Contains Parts with Sharp Points and Edges, and Components are Packed in Plastic Bags That Can Present a Choking Hazard to Children. ⚠

NOTE: Please inspect the parts for damage from shipping and/or any missing parts. If you suspect there may be damage or a shortage, contact us within **5-days** of delivery to report shipping damage or within **30-days** of delivery to report missing or incorrect parts for a warranty replacement at no cost and we will send replacement parts if needed. At this time, visualize how the components fit together and determine if you have identified all necessary parts.

Models with Valance: NO21, NO32, NO43

Awning Size	Width in Inches	Awning Size	Width in Inches
3	40.5	12	148.5
4	52.5	13	160.5
5	64.5	14	172.5
6	76.5	15	184.5
7	88.5	16	196.5
8	100.5	17	208.5
9	112.5	18	220.5
10	124.5	19	232.5
11	136.5	20	244.5

Due to the variety of construction materials, building surfaces, and mounting applications, Awntech **does not supply the hardware to install your awning.** You will need to consult a contractor or purchase installation hardware from your local hardware store. We advise you on different surface applications as follows:

CONCRETE/STUCCO: 1/4" x 3" Masonry anchor bolts or Tapcon screws with washers.

WOOD/SIDING: 1/4" x 3" Lag screws/bolts plus nuts and washers.

OTHER MATERIALS: CONSULT A PROFESSIONAL

Before you begin, take inventory of all parts included by comparing the contents of your package to the parts list corresponding to the size of awning you received. Each piece should be identifiable by a label.

Awning Size in Feet	3-4	5	6-7	8-10	11-12	13-18	Custom
(TB) Top Bar	1	1	2	2	3	3	
(FB) Front Bar	1	1	2	2	3	3	
(BB) Back Bar	2	2	2	2	2	2	
(CS) Cover Support	2	3	3	5	4	7	
(SA) Spear Arm	2	2	2	2	2	2	
(WS) Wall Support	0	1	1	3	2	5	

*(CS) count includes Center Cover Supports (CCS)

Parts:

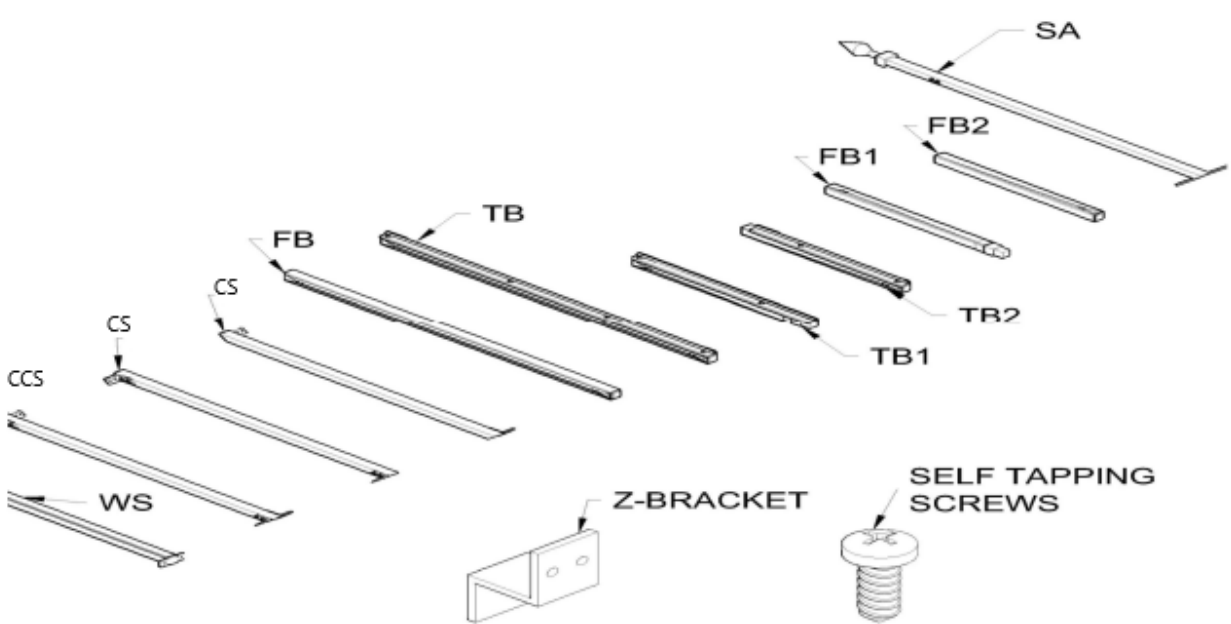

All awning sizes 6' wide and larger will consist of multiple Top Bar (TB) and Front Bar (FB) pieces that combine to make one whole Top Bar or Front Bar. These parts will be labeled (TB1), (TB2), (FB1), (FB2), etc. Awnings 5' wide and larger will also have additional Cover Supports (CCS) and Wall Supports (WS).

Hardware package includes: Z-brackets and self-tapping screws.

NOTE: You will find that fittings have been pre-installed in the frame parts as we have pre-assembled and inspected the awning for you in the factory.

Tools required: Electric Impact Drill, Rubber Hammer, Installation Anchors (as per your surface material), Tape Measure, Safety Glasses, Level, Ladder, and #2 Pencil. You may also wish to have an assistant depending on the size and weight of the awning.

ASSEMBLY

NOTE: New Orleans frame must be assembled on the wall as there is no connecting part between Spear Arm (SA) and Top Bar (TB).

Step 1) The Top Bar (TB) must be installed first. Mount Provided Z-Brackets to wall surface, and insert TB into brackets. Secure Z-brackets to TB with self-tapping screws. Please keep in mind there will be no pre-drilled holes on the TB for the Z-Brackets so you can have the flexibility to place them where they are needed. (Please see the chart below for the height measurements)

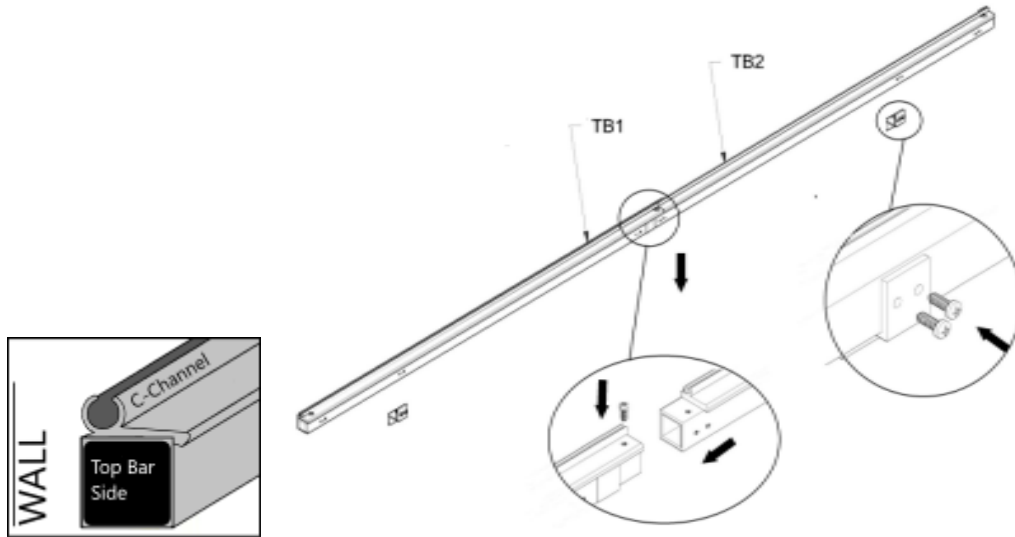

Step 2) Install the Spear Arms (SA) into the mounting surface. The space between the top of the TB and the bottom of the SA is indicated below.

Model	Space Between TB and SA	Height w/ Valance	Projection
NO21	24	19	16
NO32	36	25	24
NO43	48	31	32

* Measured in inches

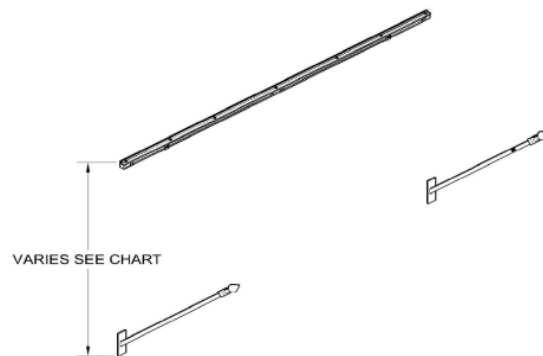

Step 3) Install the Front Bar (FB) to the Spear arms (SA). Secure with self-tapping screws. Velcro will face out.

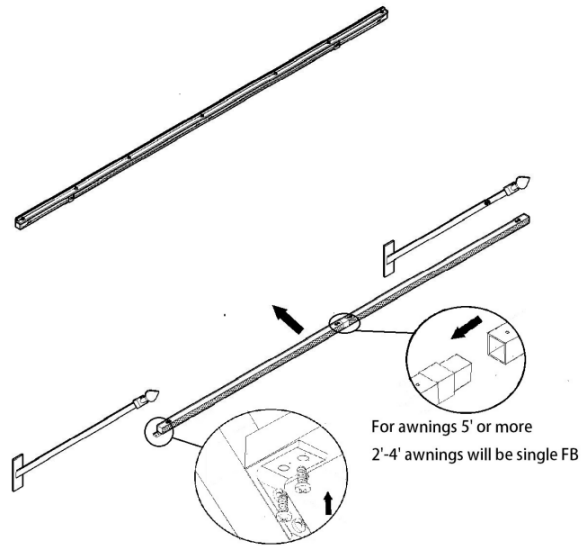

Step 4) Install the Cover Supports (CS) (left and right) with arrow facing upwards. Secure them with self-tapping screws, the holes on the FB and TB are pre-drilled. Velcro on CS faces inward.

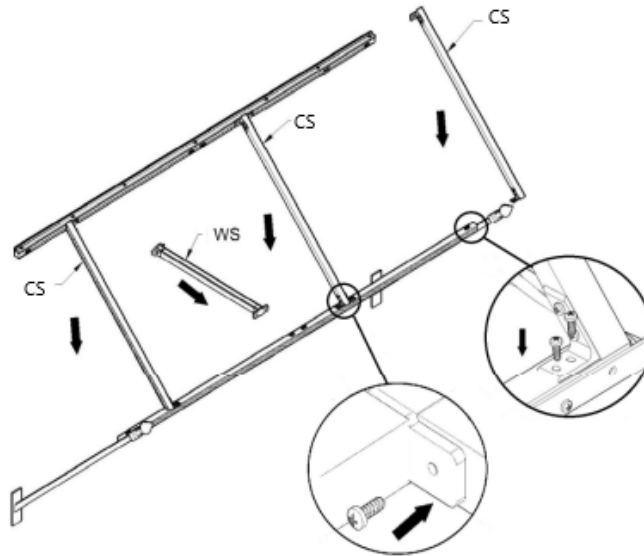

The New Orleans frame is complete.

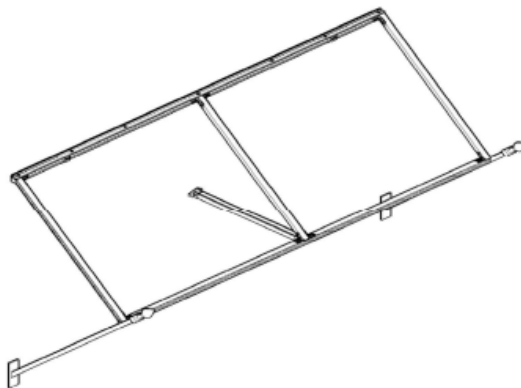

INSTALLING THE COVER

Step 5) Slide the tubing at the top of the fabric cover into the C-Channel on the top of **TB**. Pull the fabric over the frame with the valance hanging down below the **CS** and **FB** bars. Once you are satisfied with the position of the cover, pull the tabs firmly and attach them to the pre-installed Velcro tape on the bars.

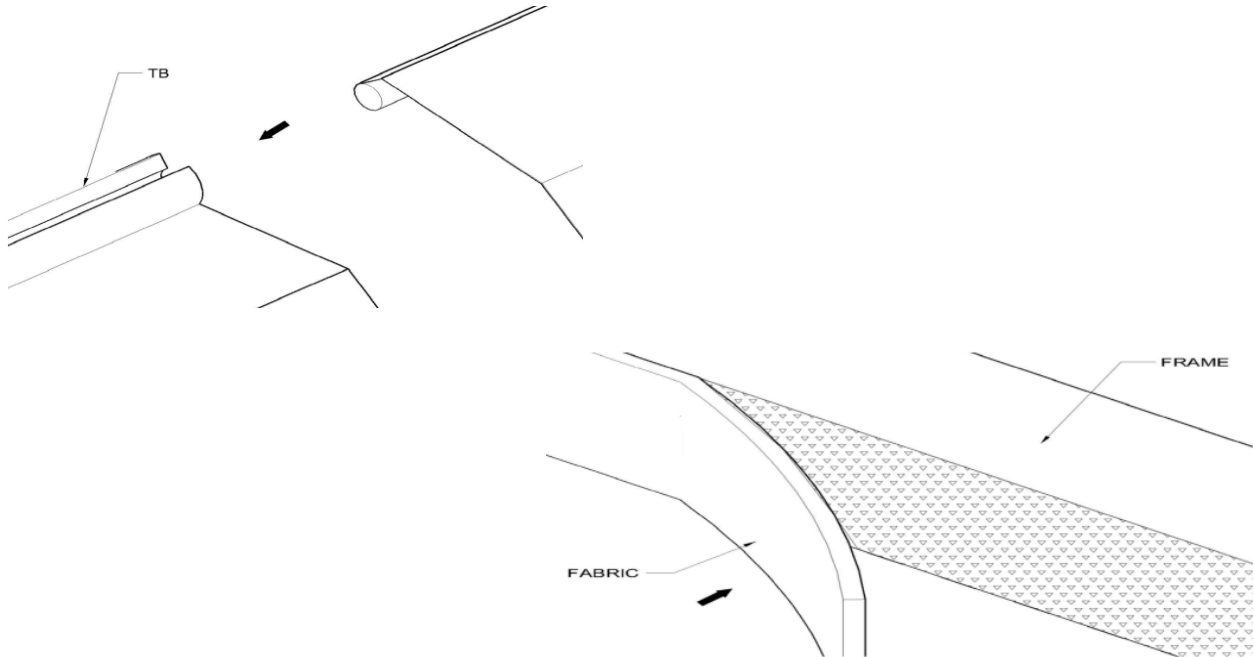

The New Orleans awning is complete.

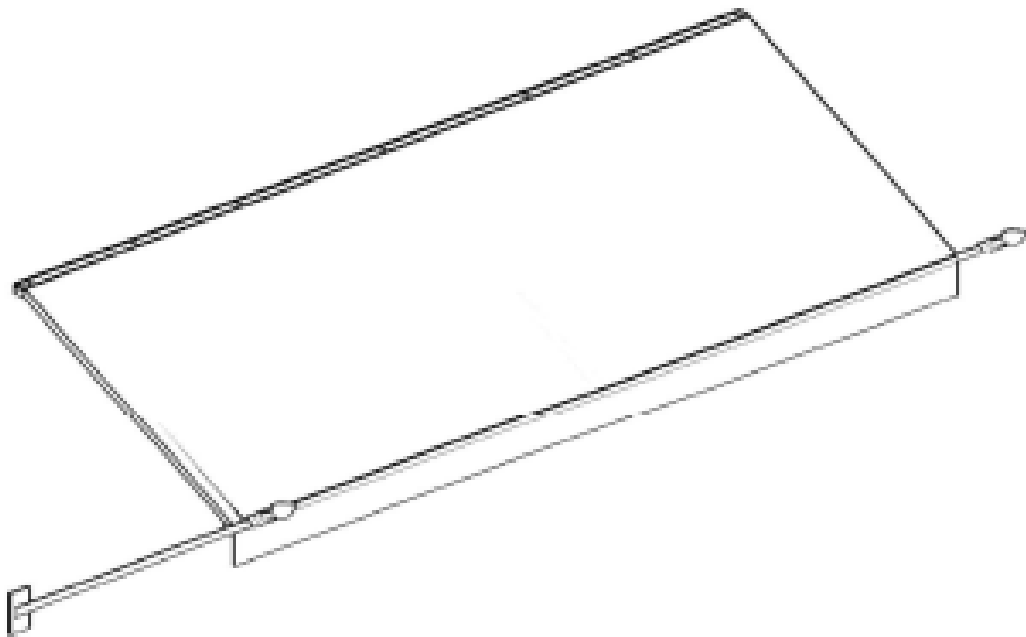

WARRANTY

<https://awntech.com/contact/product-warranty/>

5-Year Manufacturer's Limited Warranty

Obtaining necessary permits is the sole responsibility of the purchaser. Purchaser/customer agrees he/she/company will NOT hold Awntech liable for improper installation, maintenance and repairs.

A. WARRANTY: 5 Year Limited Manufacturer's Warranty (Prorated by the month)

B. WHO GIVES THIS WARRANTY? Awntech Corporation, 10950 S. Pipeline Road, Euless, TX 76040

C. WHO IS ENTITLED TO THIS WARRANTY? This Warranty applies only to the original purchaser who paid for the product and may not be assigned or transferred to subsequent owners. This Warranty applies only to products purchased and installed in the United States.

D. WHAT ARE THE RESPONSIBILITIES OF AWNTECH UNDER THIS WARRANTY? Subject to the terms and conditions set forth herein, Awntech Corporation will furnish replacements for parts found by Awntech Corporation to be defective in design, manufacture or assembly, under each specific component or product warranty as set forth below.

E. WHAT ARE THE RESPONSIBILITIES OF THE ORIGINAL PURCHASER UNDER THE WARRANTY?

- Before any claims may be made under this Warranty, the original purchaser must have paid in full for the product covered under the Warranty, according to the terms and conditions of the pay-plan defined in the original order. IF THE PURCHASER HAS FAILED TO MAKE FULL PAYMENT, THIS WARRANTY SHALL BE NULLIFIED AND AWNTECH CORPORATION SHALL BE RELIEVED FROM ANY RESPONSIBILITY OR LIABILITY UNDER THIS WARRANTY. The purchaser agrees and acknowledges that this Warranty agreement constitutes an executor contract.

- The purchaser must use care in installation, maintenance, operation, use, and storage of the product in accordance with the instructions contained in the owner's manual. ANY FAILURE TO INSTALL, MAINTAIN, OPERATE, USE AND STORE THE PRODUCT IN ACCORDANCE WITH THE INSTRUCTIONS CONTAINED IN THE OWNER'S MANUAL WILL NULLIFY THIS WARRANTY AND RELIEVE AWNTECH CORPORATION FROM ANY RESPONSIBILITY OR LIABILITY UNDER THIS WARRANTY.

- Promptly notify Awntech Corporation of any claims.

- At Awntech's request the purchaser may be required to provide a photographs or videos (if necessary) of any defective parts. The purchaser may also be required to pay a deposit until the defective parts are returned to Awntech Corporation for inspection. The purchaser must obtain a return authorization form from Awntech Corporation's customer service department prior to the return of any merchandise and after having received such authorization, return the part or product, freight prepaid, to Awntech Corporation.

F. WHAT IS COVERED UNDER THIS WARRANTY? The following components of Awntech Beauty-Mark® models and their accessories (defined as accessories attached to the awning) are covered under this Warranty, subject to the limitations set forth below. These components have a five (5) year limited (prorated) warranty, against manufacturer's defects as outlined below: (a) Should the purchaser promptly notify Awntech Corporation of such defects within one year (12 months) from the date of the original purchase, the defective component will be replaced at no charge to the purchaser. Awntech reserves the right to ask for the defective part to be returned and/or photos/videos of the defective part. (b) After one year but within five years (60 months) from the date of the original purchase, a defective component will be replaced upon the purchaser's payment of 1/60th of the full retail cost of the component for each month of use prior to the claim.

FIXED AWNINGS – COVERED COMPONENTS

Structural supports - all supporting components are warranted not to fail for five (5) years prorated. Acrylic fabric - warranted for five (5) years prorated against:

a) Excessive fading under normal conditions if maintained, operated, used, and stored in accordance with the instructions contained in the owner's manual.

b) Mildew on acrylic fabric. Mildew will not form on the fabric itself, but may form on dirt and dust that have not been removed from it. Please see maintenance instructions for proper cleaning—outlined in owner's manual.

G. WHAT IS NOT COVERED UNDER THIS WARRANTY?

•Any failure or damage of the components that results from any intentional or negligent actions by the purchaser or by any other person is not covered by this Warranty.

•It is the responsibility of the purchaser to securely fasten the awning to studs, joists, headers or other structural members. Any failure or damage that results from the awning falling from its installed position is not covered by this Warranty.

•Labor charges connected with installation of replacement parts are not covered by this Warranty. •Freight expenses to and from Awntech Corporation are not covered by this Warranty and must be paid by the purchaser.

•Stretching of fabric or damage to any structural component caused by wind or water pooling on the fabric or any other weather is not covered by this Warranty, except for the limited warranty of the acrylic fabric as specifically set forth herein.

H. GENERAL PROVISIONS AND LIMITATIONS

•The warranty granted herein is the exclusive remedy for the purchaser. Awntech Corporation makes no other warranties to the purchaser, express, statutory, implied or otherwise and all implied warranties, including without limitations, implied warranties of merchantability and fitness for a particular purpose, are hereby disclaimed.

•To the extent permitted by law, Awntech Corporation shall have no liability to the purchaser or any other person for incidental, special, consequential, indirect or similar damages of any kind or nature whatsoever, whether arising out of breach of warranty or other breach of contract, negligence or other tort, or otherwise, even if Awntech Corporation shall have been advised of the possibility or likelihood of such potential loss or damage. In no event shall Awntech Corporation be liable for loss of profits and/or wages.

•Some states do not allow limitations on how long an implied warranty lasts, or do not allow the exclusion or limitation of incidental or consequential damages, so the above limitations may not apply to you.

•This warranty gives you specific rights, and you may have other rights, which vary from state to state. Awntech Corporation, 10950 S. Pipeline Rd., Bldg. 1, Euless, TX 76040 / Ph 817-354-9600; Fax 817-354-9612 / Warranty@awntech.com

G. RETURNS & DAMAGES

RETURN QUALIFICATION: You can only return a product if it is defective upon arrival. If you simply do not like the product or if you did not measure correctly, you will only be qualified for a merchandise credit and you will be required to pay for shipping the product back to Awntech in re-stockable condition. There will be a 25% restock fee applicable.

SIZES 10' and LARGER or CUSTOM AWNINGS: Any awnings 10' or larger or customized at Purchaser's request are considered non-returnable for either refund or exchange.

DAMAGED MATERIAL: Damage occasionally occurs during shipping. Scrapes dents and rips in the outer packaging that could indicate possible damage should be described to the carrier at the time of delivery. If damage to the product seems apparent, the shipment should be refused.

FABRIC DYE-LOT AND LIGHTING VARIATION: Fabric dyes may carry slightly from run to run. This is a normal and unavoidable. Different lighting types and lighting direction may cause the fabric you choose on the website to appear slightly different than the actual fabric does in full sunlight.

RETURNS/ORDER EXCEPTIONS: Phone :817-354-9600, Fax 817-354-9612, E-mail customers@awntech.com

TO ACQUIRE A RETURN OR REPAIR AUTHORIZATION NUMBER YOU MUST GO THROUGH THE WARRANTY PROCESS: Email Photos of damaged parts to: warranty@awntech.com or mail to:

**Awntech Corporation,
10950 S. Pipeline Rd., Bldg 1,
Euless, TX 76040**

Authorized returns should be shipped to:

**Returns Department:
Awntech Corporation,
10950 S. Pipeline Rd., Bldg 1,
Euless, TX 76040**

CLEANING CHART FOR TYPICAL AWNING STAINS:

STAIN	RECOMMENDED CLEANING SOLUTIONS
CHARCOAL	Vacuum, then liquid detergent
CHEWING GUM	Acetone
SODA	Liquid detergent
CAR GREASE	Acetone
IRON RUST	Oxalic or citrus acids, water
MILDEW	1 cup of bleach and ¼ mild soap per gallon of water
OIL	Acetone
PAINT (LATEX) WET	Liquid detergent, water
PAINT (LATEX) DRIED	Paint, oil or grease remover
PAINT (OIL OR LACQUER)	Paint, oil or grease remover
SUNTAN LOTION	Pine Power® or pine oil detergent
TREE SAP	Turpentine, liquid detergent

CLEANING & CARE: Awnings should be cleaned at least once a year in low maintenance areas or twice a year in high maintenance areas (see high maintenance areas above). Cleaning consists of brushing off debris with broom, brushing on a non-detergent cleaning compound (such as a solution of 1-part vinegar to 1-part water), allowing the awnings to sit for 20 minutes, and then rinsing. Remember that your awning is an exterior product; You’ll need to clean your awning to preserve and extend its beauty and life. Please refer to the cleaning and care chart below if you acquire a stain from one of the ingredients on the list.

NORMAL WEAR & TEAR: The weather in certain regions of the country contributes to wear and tear of the awnings. If you live in these areas (High maintenance areas: FL, TX, NM, AZ, NV or high-altitude areas) weather conditions (including sun) can take a toll. Normal wear and tear is not covered in our warranty and should be expected. Damages caused by improper anchoring, strong winds, snow or ice are not considered defects. We offer replacement fabric at affordable prices