

135992 - 01



Demeyere  
GROUP

FR

NOTICE DE MONTAGE

EN

ASSEMBLY INSTRUCTIONS

DE

MONTAGEANLEITUNG

ES

INSTRUCCIONES DE MONTAJE

NL

MONTAGEVOORSCHRIFT

IT

ISTRUZIONI DI MONTAGGIO

PT

INSTRUÇÕES DE MONTAGEM

CR

NAPUTCI ZA MONTAŽU

HU

ÖSSZESZERELÉSI UTASÍTÁSOK

تعليمات التركيب (ع)

Max  
17Kg / 37.5Lbs

Max  
8Kg / 17.6Lbs

Max  
6Kg / 13.2Lbs

Max  
10Kg / 22Lbs



2h00.

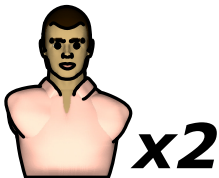
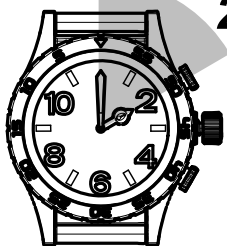

190323



Fabriqu  en France  
Made in France

S.A. Meubles DEMEYERE - 178-184 rue de la Pr v t   
59840 P renchies - FRANCE

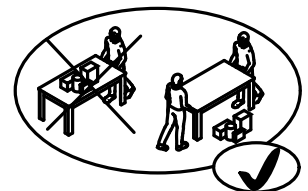
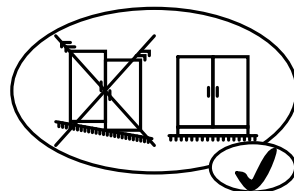
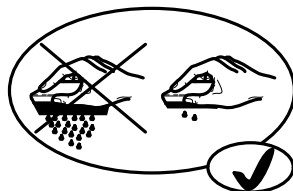
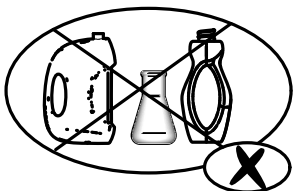
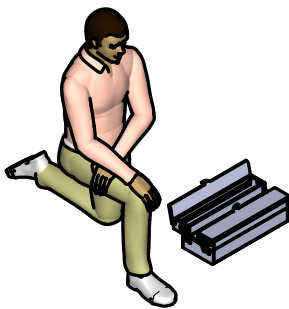
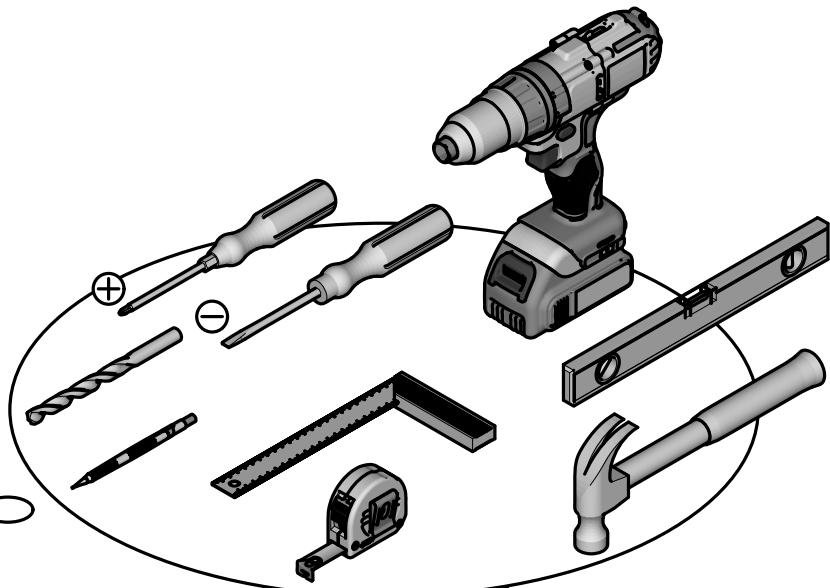
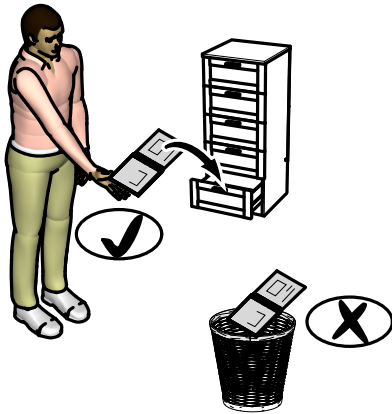
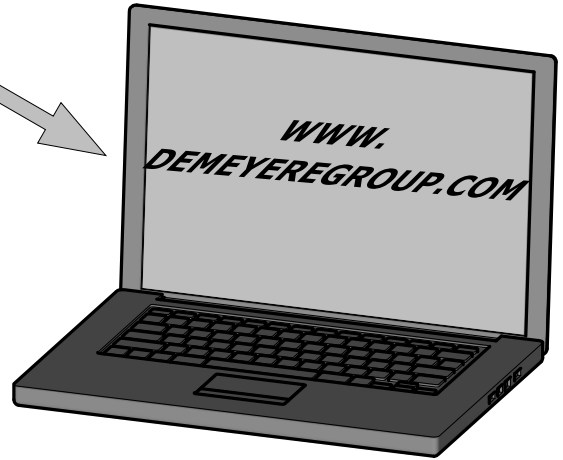
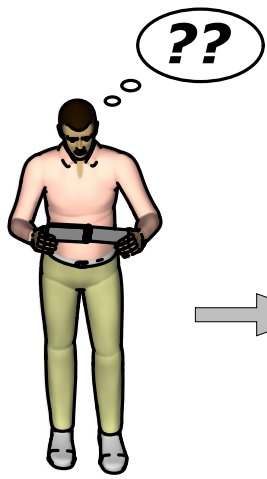

Donnez ou recyclez vos meubles.



Association

ou











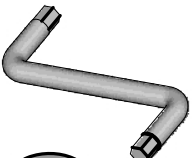

Magasin



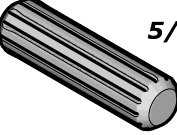

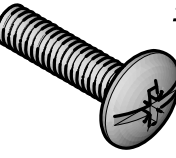
ou

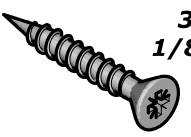

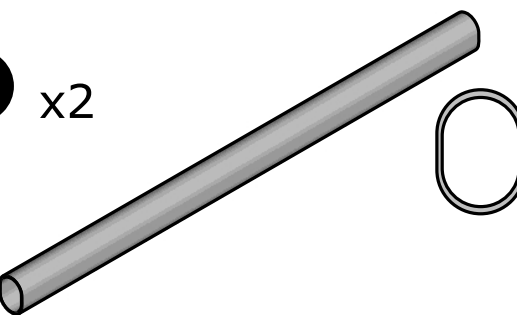
Déchèterie

<https://quefairemesdechets.fr>

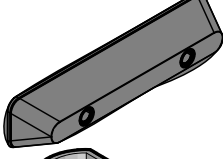
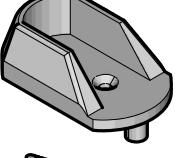
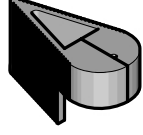
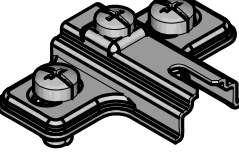
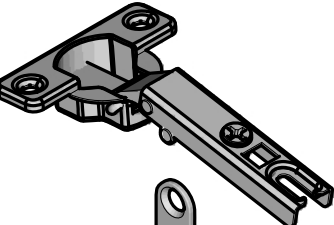
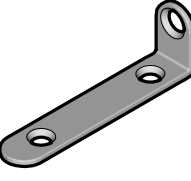
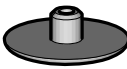
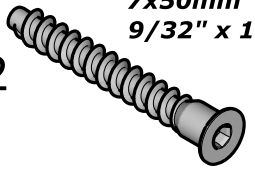
- A** x1 
- B** x4 
- C** x8 
- D** x8 
- E** x20  **8x30mm**  
**5/16" x 1 3/16"**
- F** x6  **4x25mm**  
**5/32" x 1"**
- G** x4  **6x25mm**  
**1/4" x 1"**
- H** x4  **3x12mm**  
**1/8" x 15/32"**
- I** x2  **3,5x30mm**  
**1/8" x 1 3/16"**
- J** x18  **3,5x15mm**  
**1/8" x 19/32"**
- K** x2 

- L** x22 
- M** x22  **Ø15mm**  
**Ø19/32"**
- N** x3 
- O** x4 
- P** x1 
- Q** x8  **H=2mm**  
**H=1/16"**
- R** x8 
- S** x2 
- T** x8 
- U** x22  **7x50mm**  
**9/32" x 1 31/32"**
- V** x2  **x25**

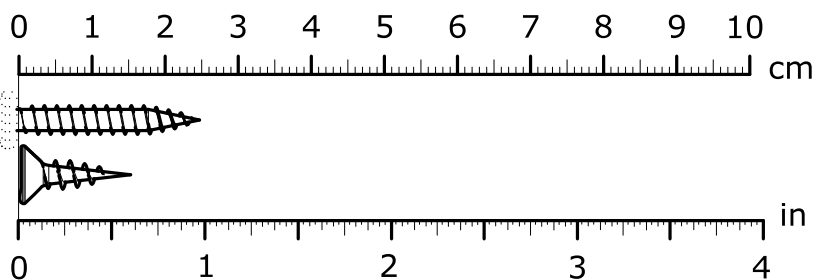

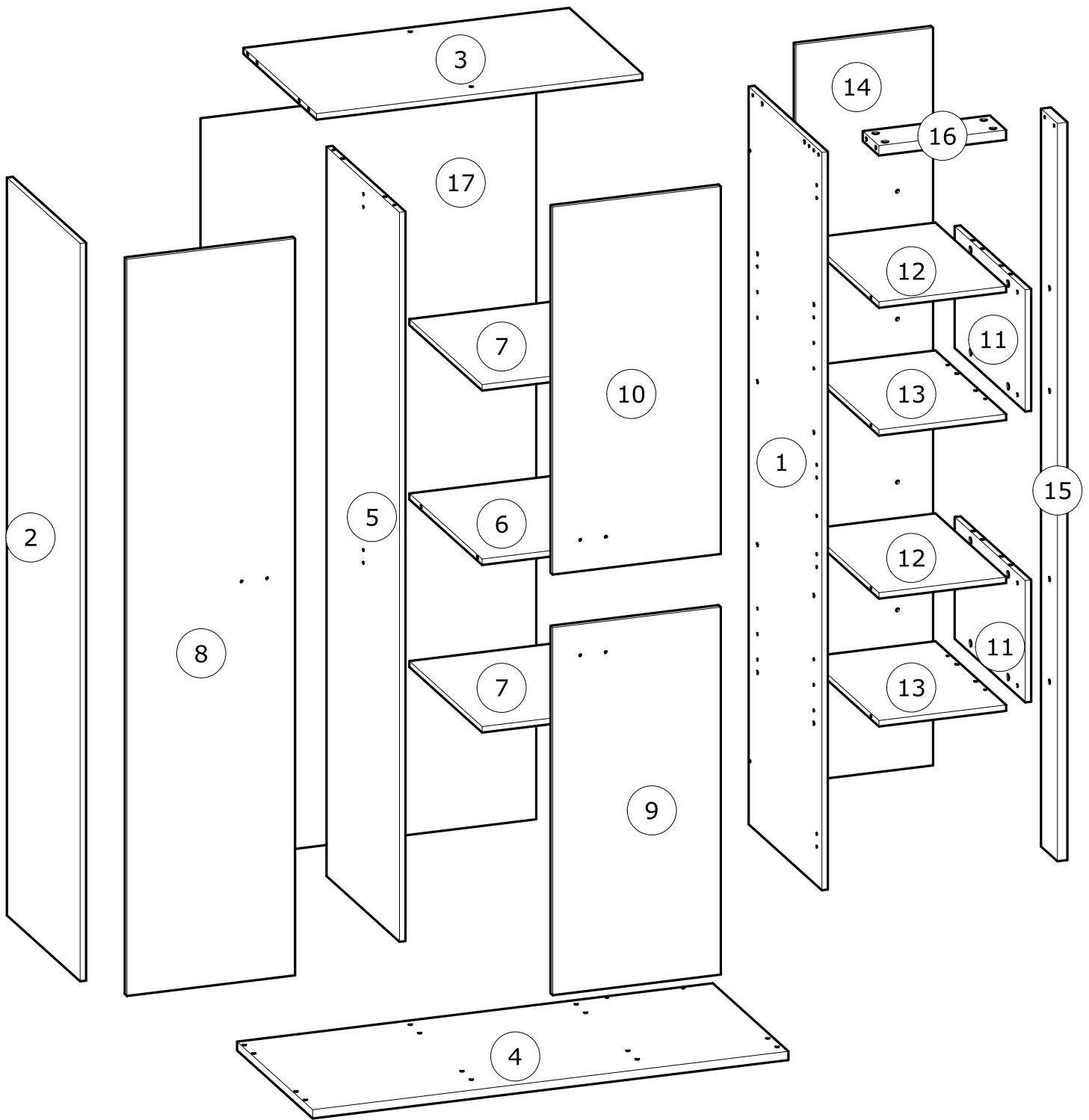

N°	MM		INCH		QTY
1	1847	x 499	72 11/16	x 19 10/16	1
2	1847	x 499	72 11/16	x 19 10/16	1
3	820	x 498	32 5/16	x 19 10/16	1
4	1197	x 515	47 2/16	x 20 4/16	1
5	1826	x 497	71 14/16	x 19 9/16	1
6	402	x 496	15 13/16	x 19 8/16	1
7	402	x 496	15 13/16	x 19 8/16	2
8	1844	x 423	72 10/16	x 16 10/16	1
9	920	x 423	36 4/16	x 16 10/16	1

N°	MM		INCH		QTY
10	920	x 423	36 4/16	x 16 10/16	1
11	305	x 481	12	x 18 15/16	2
12	320	x 482	12 10/16	x 19	2
13	320	x 482	12 10/16	x 19	2
14	1846	x 345	72 11/16	x 13 9/16	1
15	1847	x 112	72 11/16	x 4 7/16	1
16	320	x 110	12 10/16	x 4 5/16	1
17	1857	x 844	73 2/16	x 33 4/16	1

FR

**AVERTISSEMENT : MEUBLE A FIXER IMPERATIVEMENT AU MUR AFIN D'EVITER SON BASCULEMENT**

- Pour installer correctement ce produit et éliminer les risques pour votre sécurité, merci de suivre exactement ce manuel d'instruction.
- Fixer le meuble au mur avec les attaches prévues à cet effet
- Les vis et les chevilles ne sont pas fournies. Utiliser des vis et des chevilles adaptées au support.

EN

**WARNING: FURNITURE TO BE ATTACHED TO THE WALL TO PREVENT OVERTURNING**

- Installation shall be carried out exactly according to those instructions-otherwise a safety risk can occur if incorrectly installed;
- Attach the furniture to the wall with the fastening provided for this purpose
- Screw and Pegs are not supplied. Use Screws and pegs adapted to the support.

DE

**WARNUNG: DAS MÖBEL MUSS AN DER WAND BEFESTIGT WERDEN, UM ZU VERHINDEN DASS ES KIPPT**

- Um das Produkt korrekt zu installieren und um Risiken für Ihre Sicherheit zu verhindern, die Gebrauchsanleitung genauestens befolgen.
- Das Möbel mit den vorgesehenen Befestigungen an einer Wand befestigen.
- Schrauben und Dübel sind nicht im Lieferumfang enthalten. Passende Schrauben und Dübel verwenden.

ES

**ADVERTENCIA: ESTE MUEBLE DEBE ESTAR SIEMPRE FIJO EN LA PARED PARA EVITAR QUE VUELQUE**

- Para instalar correctamente este producto y eliminar los riesgos para la seguridad, seguir exactamente las instrucciones del manual.
- Fijar el mueble a la pared con las sujeciones previstas a este efecto.
- Los tornillos y los tacos no están incluidos. Utilizar tornillos y tacos adaptados al soporte.

NL

**WAARSCHUWING: MEUBEL MOET VERPLICHT AAN DE MUUR BEVESTIGD WORDEN ZODAT HET NIET KAN OMVALLEN**

- Om dit product correct te installeren en alle risico's voor uw veiligheid te elimineren, gelieve de instructies in deze handleiding nauwgezet op te volgen.
- Zet het meubel vast aan de muur met de hiertoe voorziene bevestigingen.
- De schroeven en pluggen zijn niet meegeleverd. Gebruik schroeven en pluggen die geschikt zijn voor het materiaal van de muur.

IT

**AVVERTENZA: MOBILE DA FISSARE IMPERATIVAMENTE AL MURO PER EVITARE CHE SI RIBALTI**

- Per installare correttamente questo prodotto ed eliminare i rischi per la vostra sicurezza, si prega di seguire esattamente il manuale d'istruzioni.
- Fissare il mobile al muro con gli appositi ganci.
- Le viti e i tasselli non sono forniti. Utilizzare viti e tasselli adatti al supporto.

PT

**ADVERTÊNCIA: MÓVEL A FIXAR OBRIGATORIAMENTE À PAREDE PARA EVITAR A SUA QUEDA**

- Para instalar corretamente este produto e eliminar os riscos para a sua segurança, é favor seguir exatamente este manual de instruções.
- Fixe o móvel à parede com as fixações previstas para o efeito
- Os parafusos e as cavilhas não são fornecidos. Utilize parafusos e cavilhas adaptados ao suporte.

CR

**UPOZORENJE : UČVRSTITE ORMARIĆ NA ZID KAKO BISTE SPRIJEČILI NJEGOVO LJULJANJE**

- Kako biste pravilno postavili ovaj proizvod i uklonili sigurnosne rizike kojima se izlažete, pridržavajte se strogo ovog priručnika s uputama.
- Postavite ormarić na zid pripadajućim sponama.Vijci i svornjci ne isporučuju se. Upotrijebite nosne vijke i svornjke.

Hu

**FIGYELEM: A BÚTORT FELTÉTENÜL RÖGZÍTENI KELL A FALHOZ, HOGY ELKERÜLJE A FELBILLENÉSÉT**

- A termék megfelelő elhelyezéséhez és a biztonságot érintő kockázatok kiküszöböléséhez pontosan kövesse ezt a használati útmutatót.
- Rögzítse a bútort a falhoz az erre a célra szolgáló rögzítőelemekkel.
- A csavarok és a tiplik nincsenek mellékelve. Használjon a tartóhoz illő csavarokat és tipliket.

العربية:

**تحذير: قطعة أثاث يلزم تثبيتها على الحائط لتجنب تارجحها**

- لتركيب هذا المنتج بشكل صحيح وتجنب المخاطر من أجل سلامتك، يرجى اتباع كتيب التعليمات هذا بالضبط.
- تثبت قطعة الأثاث على الحائط بواسطة العلاقات المخصصة لهذا الغرض
- إن البراغي والخوابير غير متوفرة مع المنتج. تستخدم براغي وخوابير ملائمة للحائط الذي يتم التثبيت عليه.

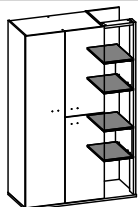

1

L x8

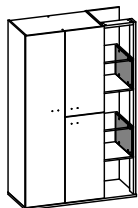
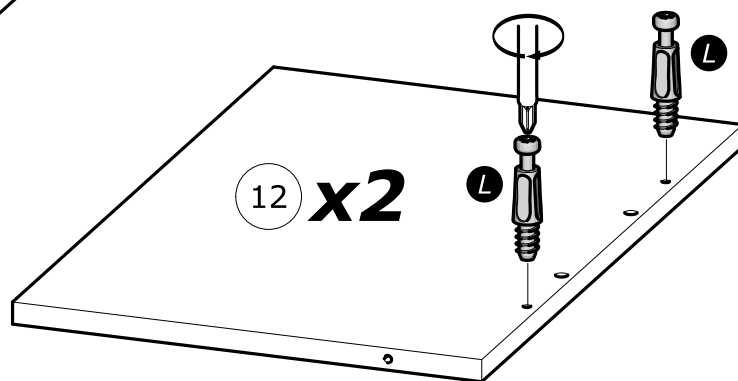
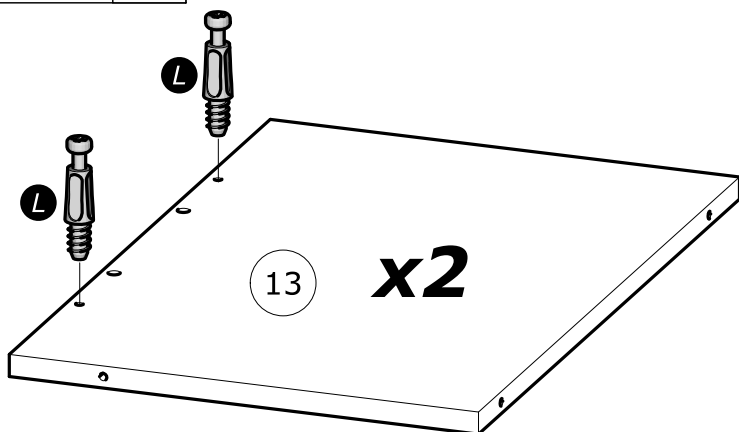

2

E x8

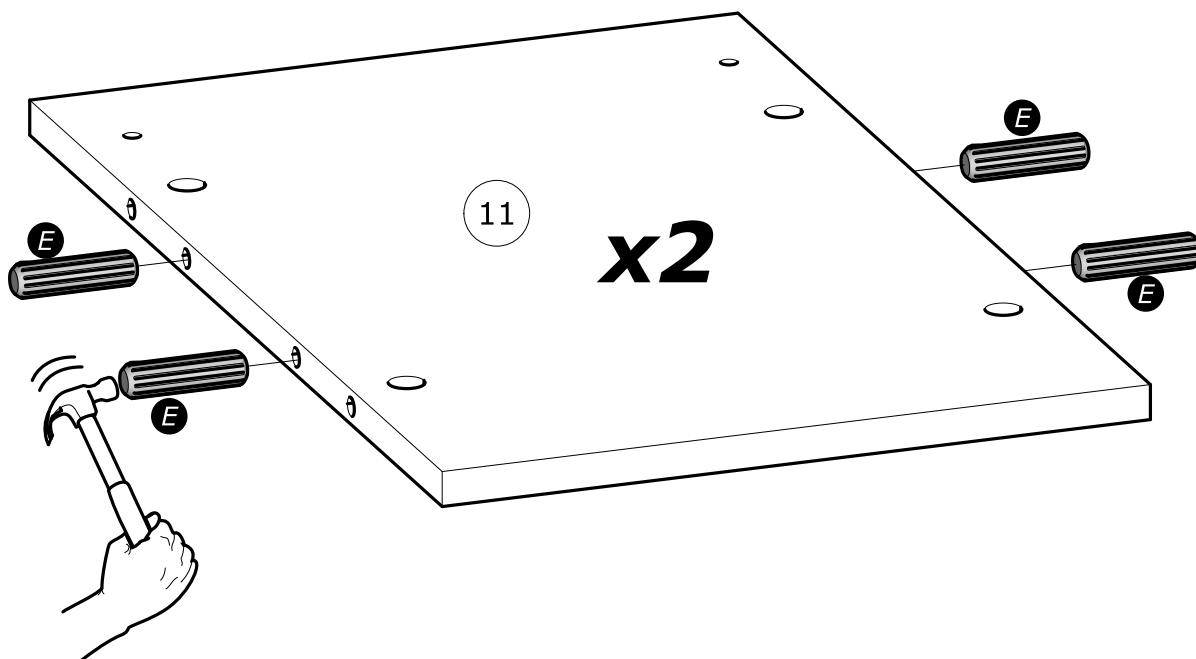

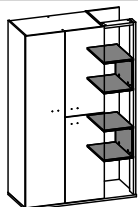

3

M x8



Ø15mm  
Ø19/32"

x2

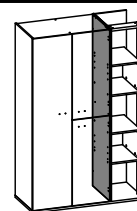
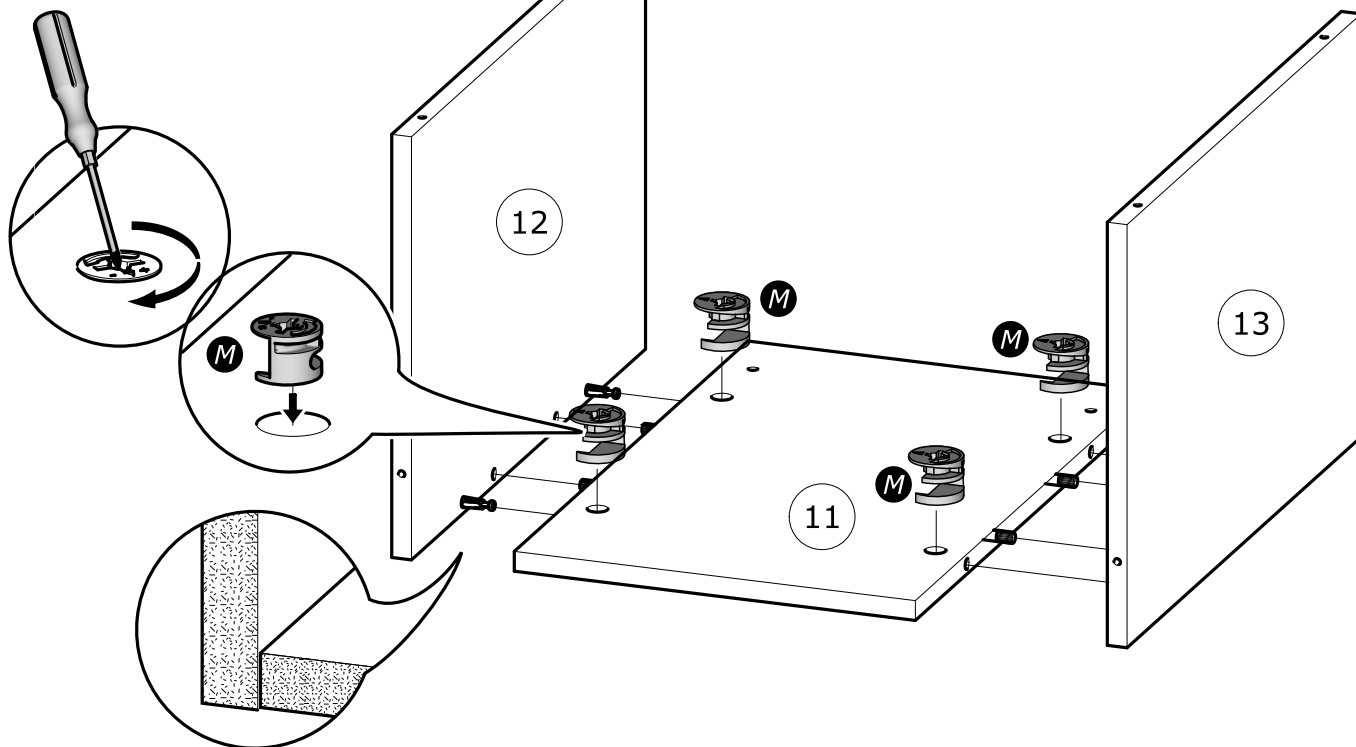

4

E x2



8x30mm  
5/16" x 1 3/16"

L x6

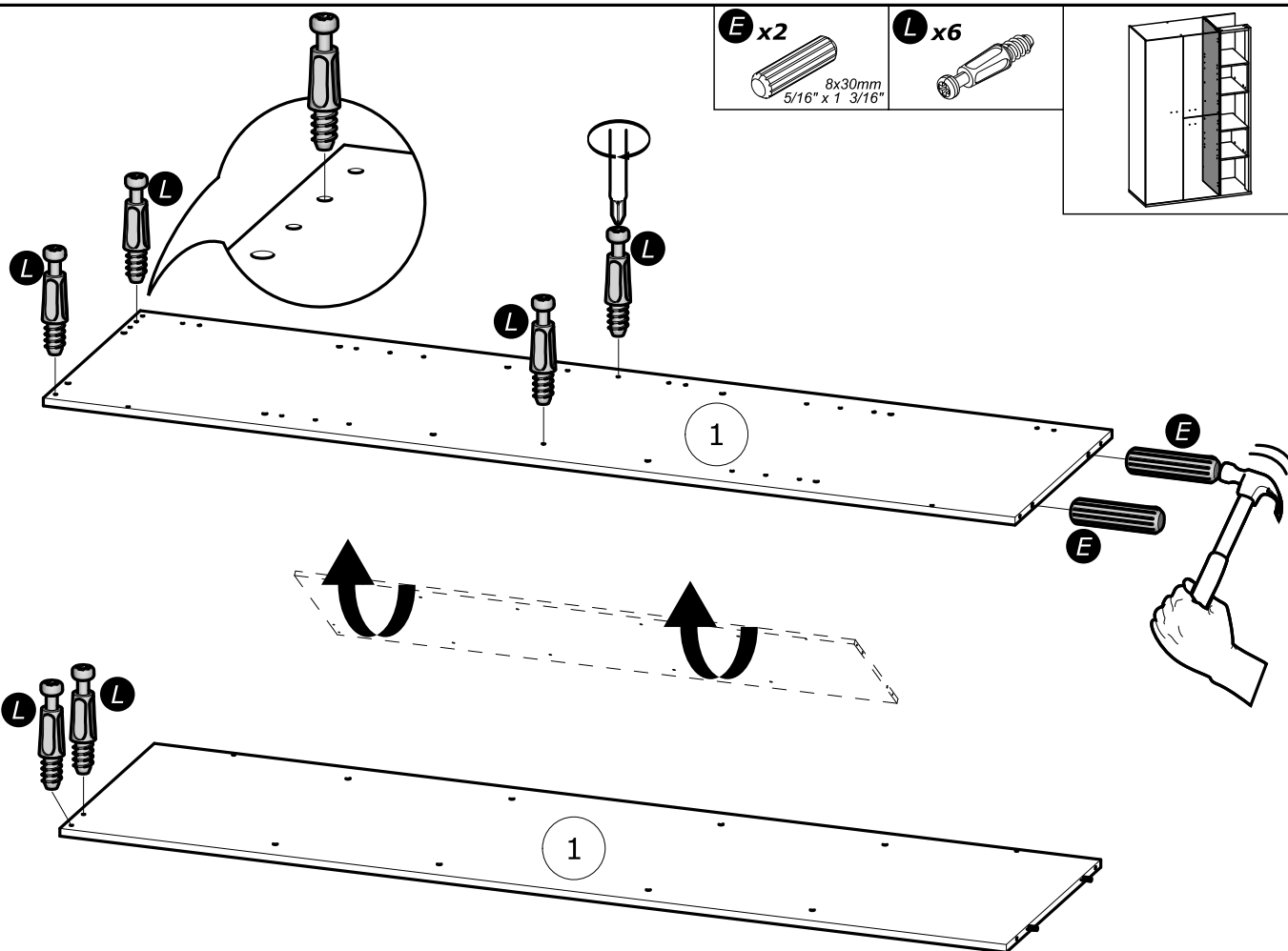

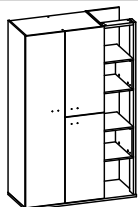

5

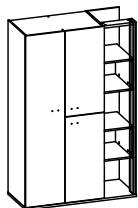
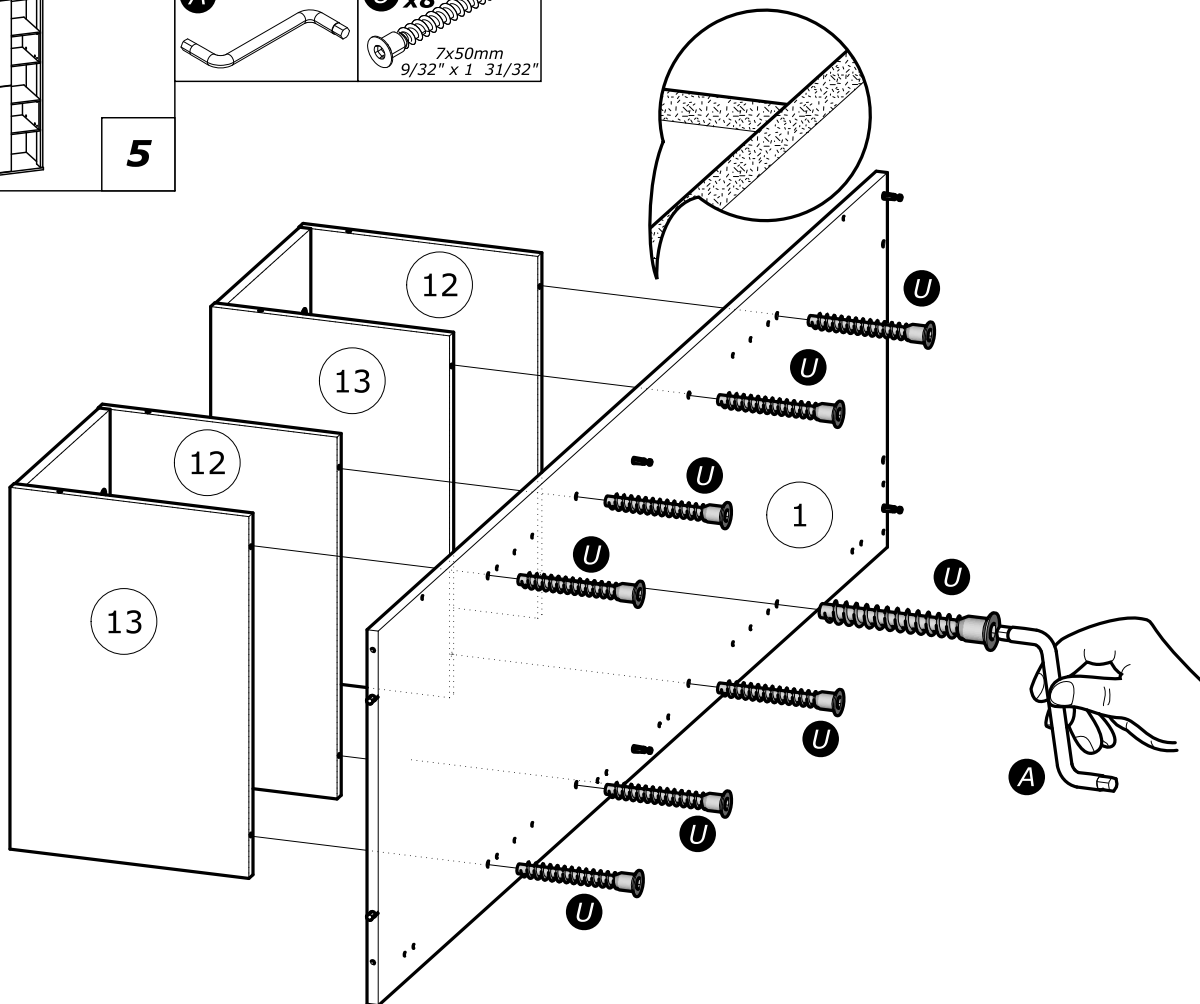
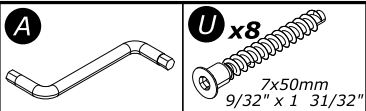

6

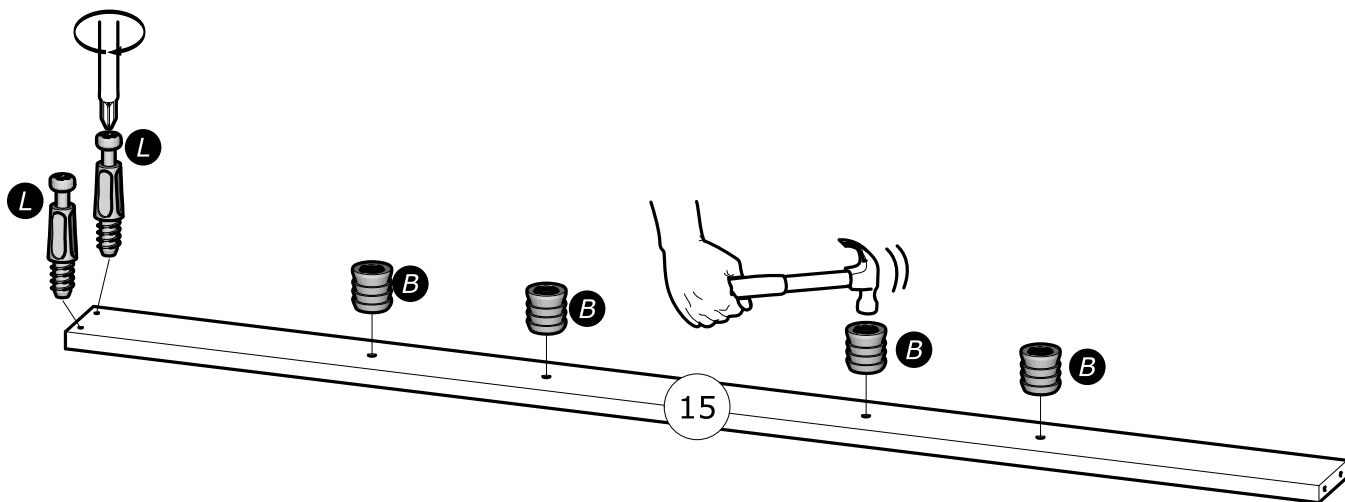
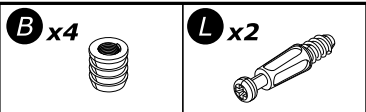

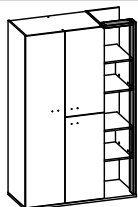

7

**M** x4



Ø15mm  
Ø19/32"

**G** x4



6x25mm  
1/4" x 1"

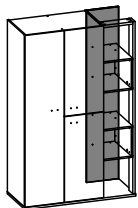
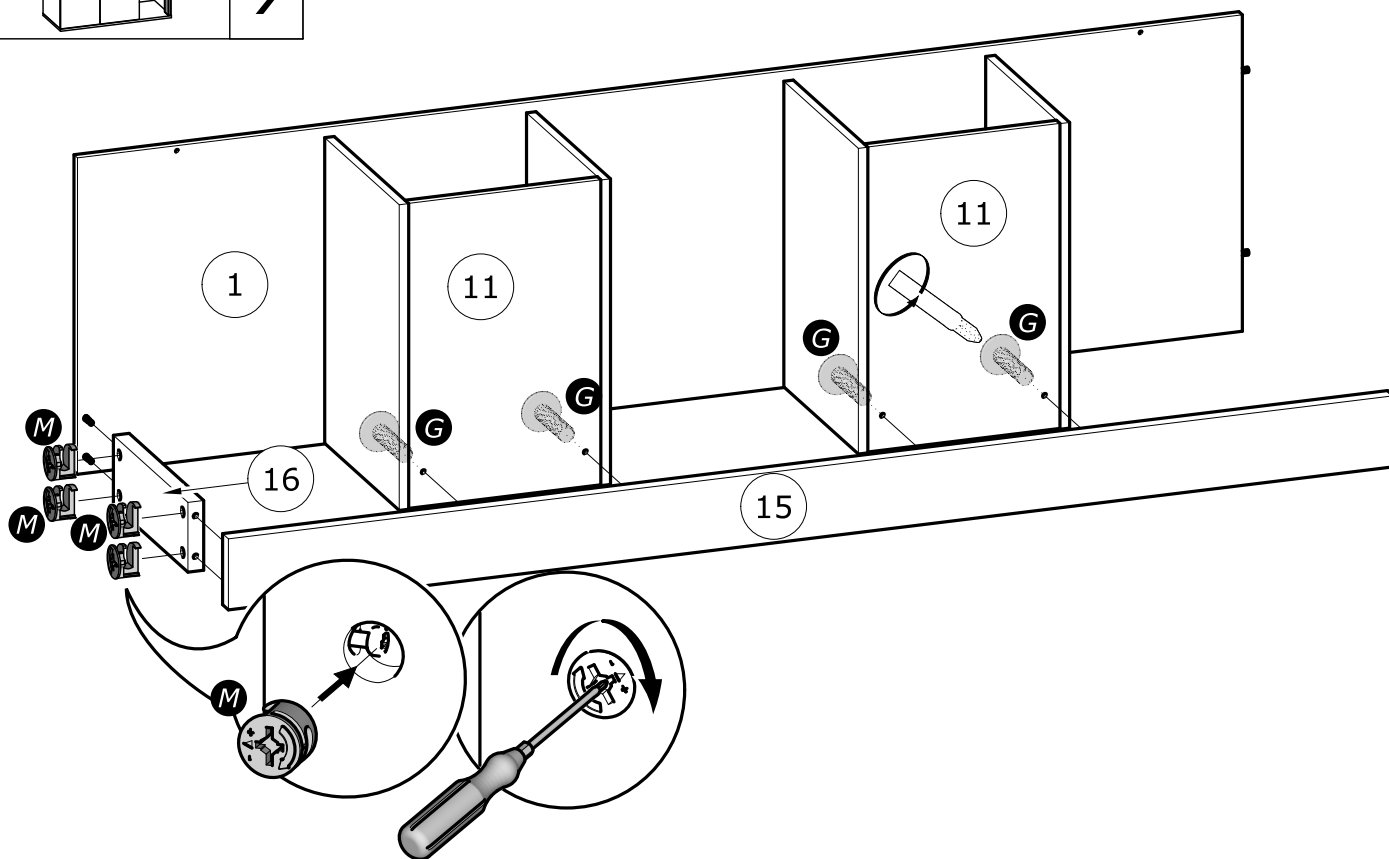

8

**A**



**U** x4



7x50mm  
9/32" x 1 31/32"

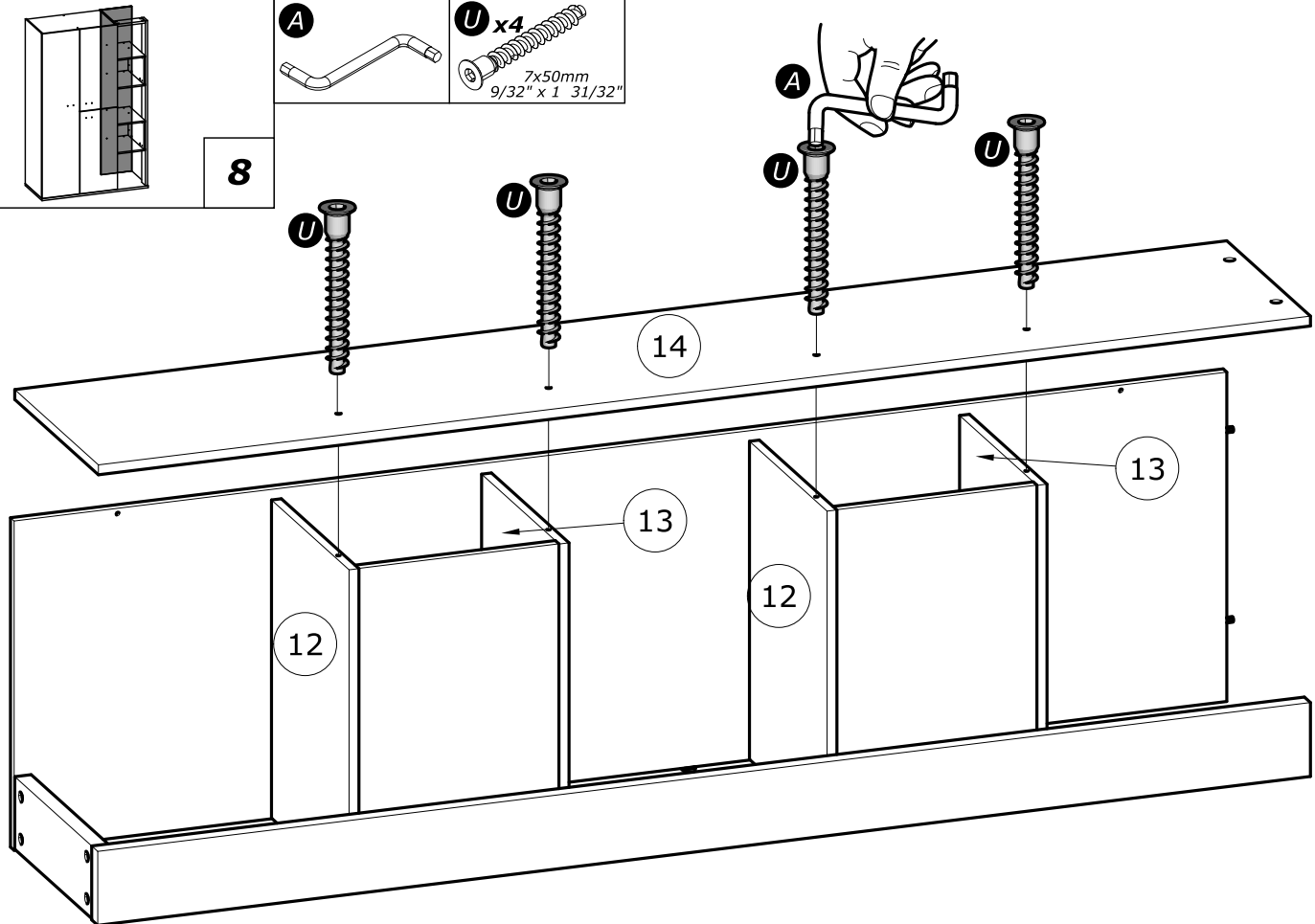

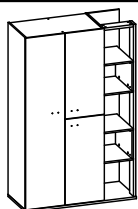

9

**I** x2

3.5x30mm  
1/8" x 1 3/16"

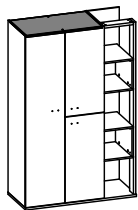
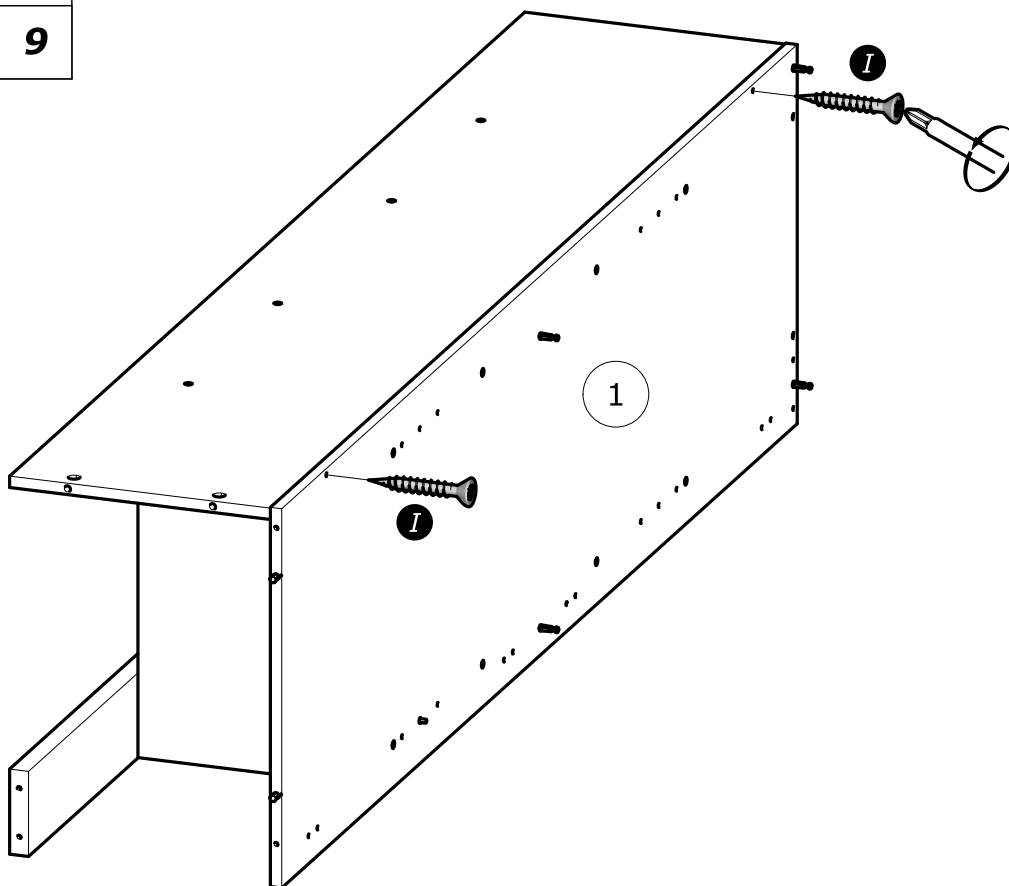

10

**E** x4

8x30mm  
5/16" x 1 3/16"

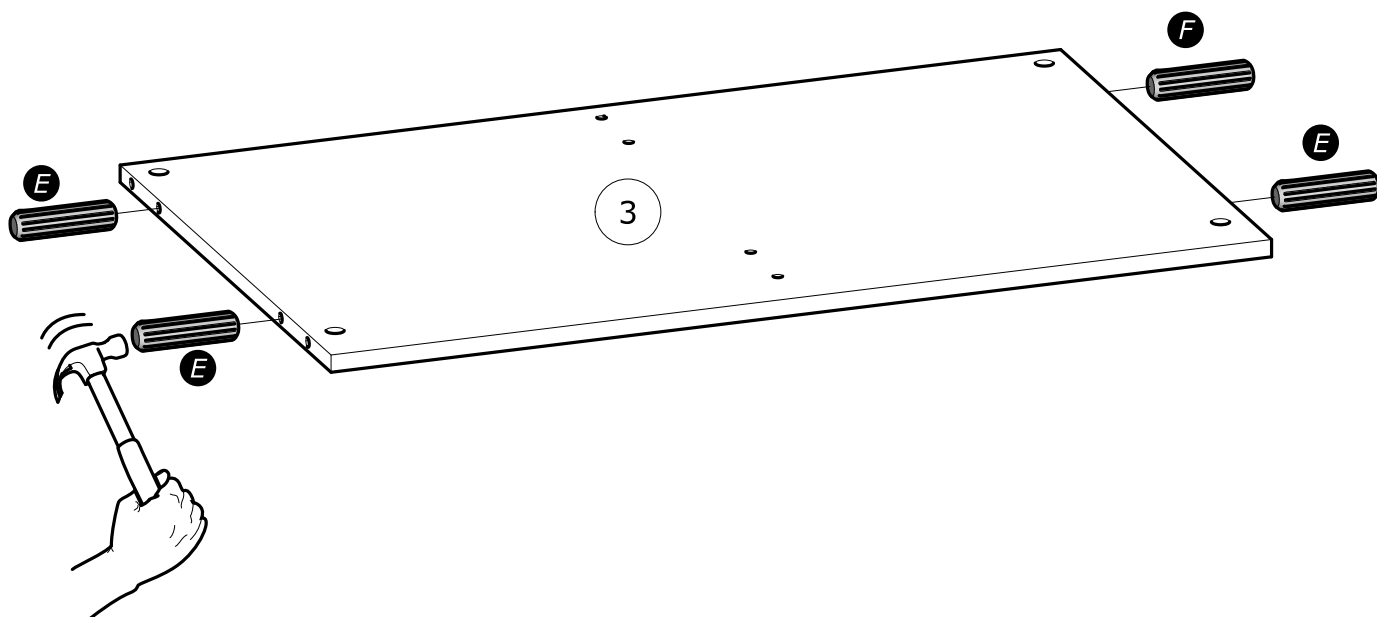

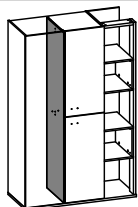

11

**E** x4  
8x30mm  
5/16" x 1 3/16"

**H** x2  
3x12mm  
1/8" x 15/32"

**O** x2

**L** x2

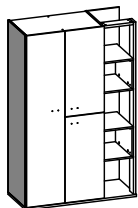
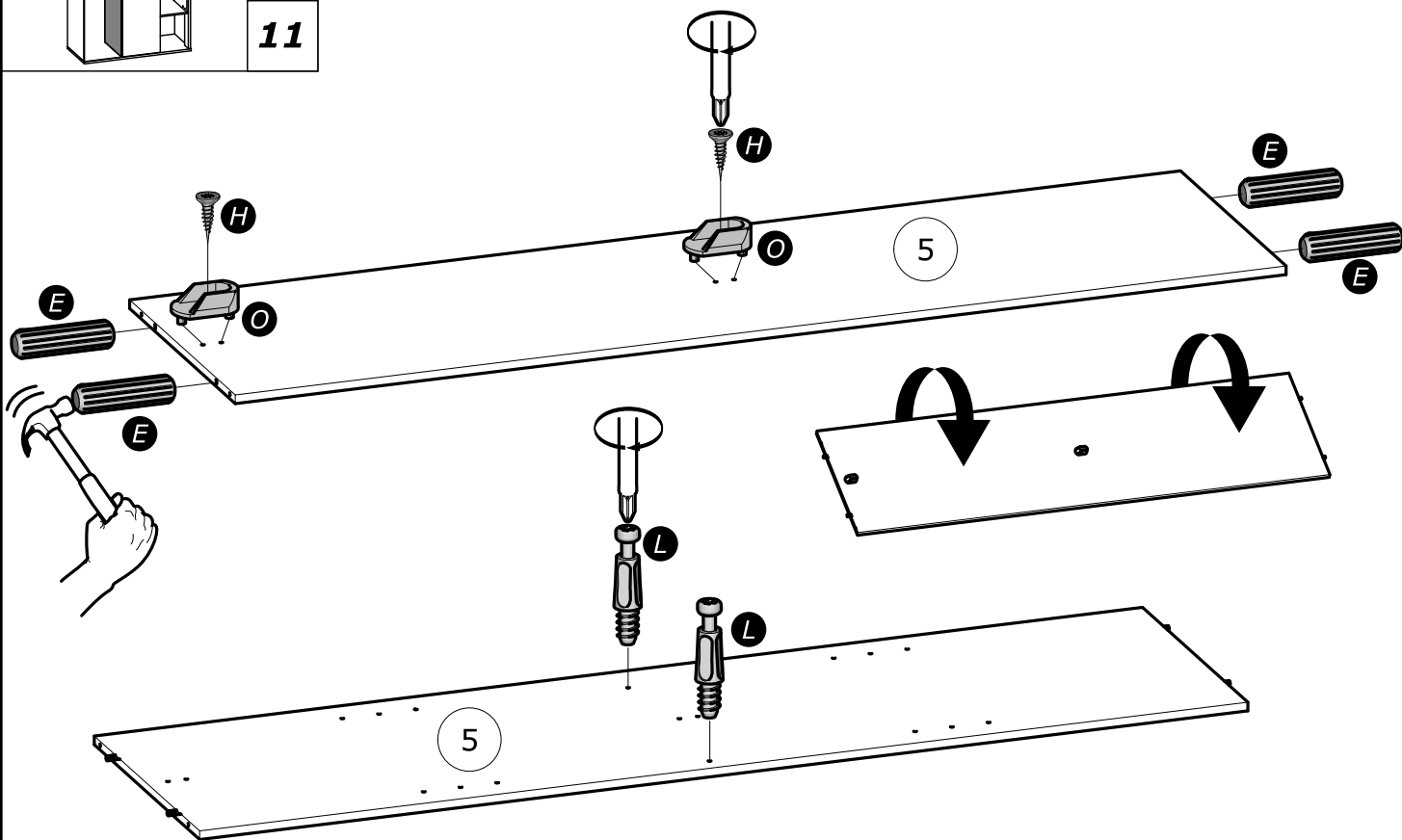

12

**E** x2  
8x30mm  
5/16" x 1 3/16"

**H** x2  
3x12mm  
1/8" x 15/32"

**O** x2

**L** x2

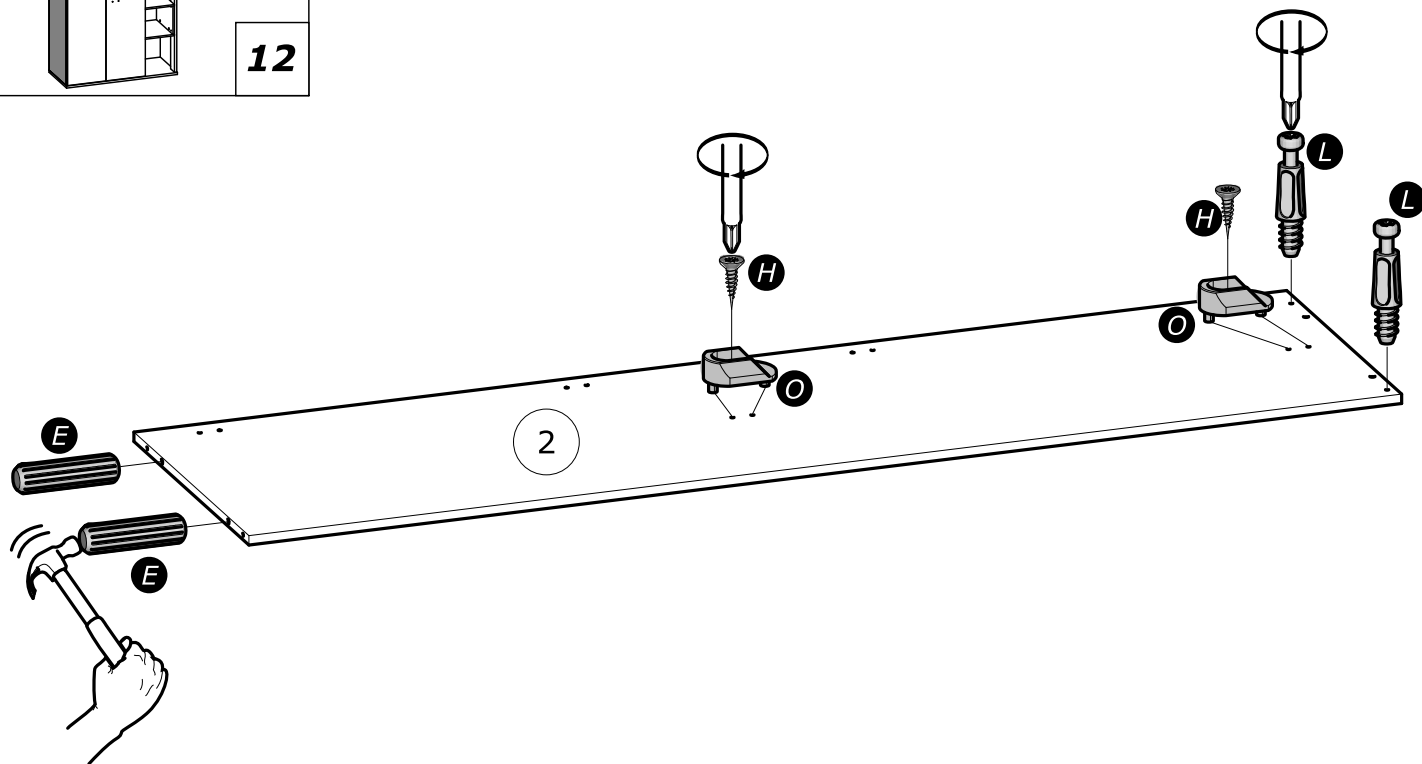

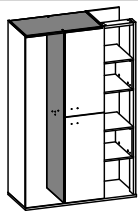

13

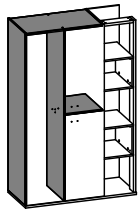
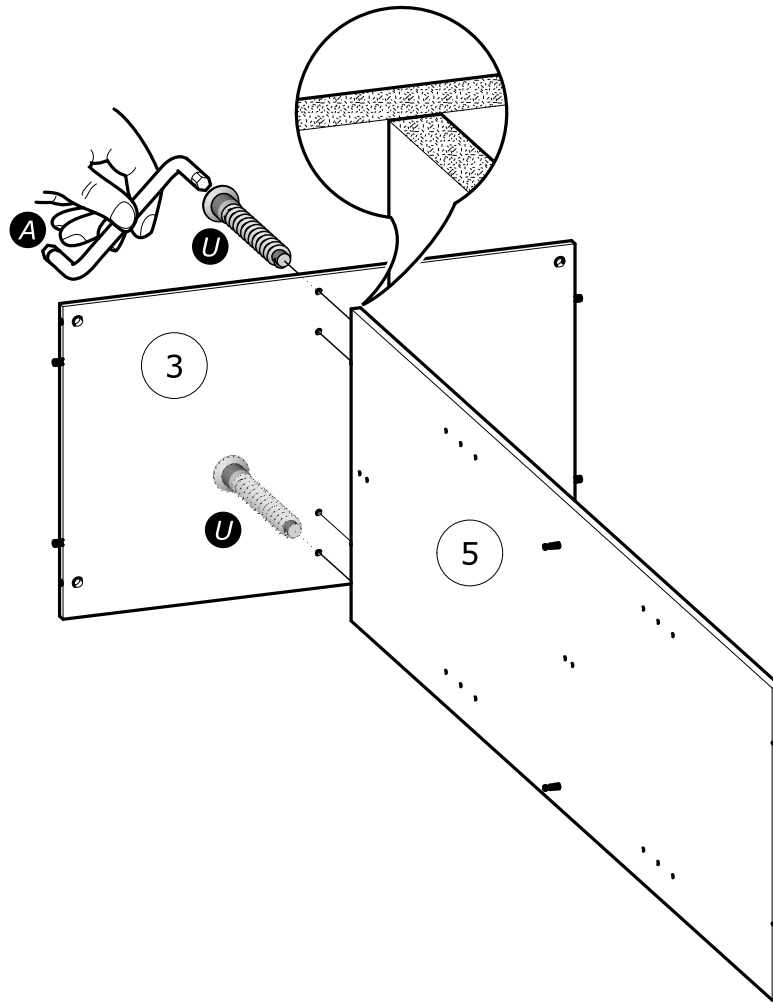
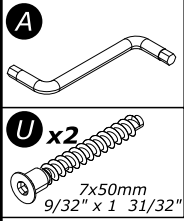

14

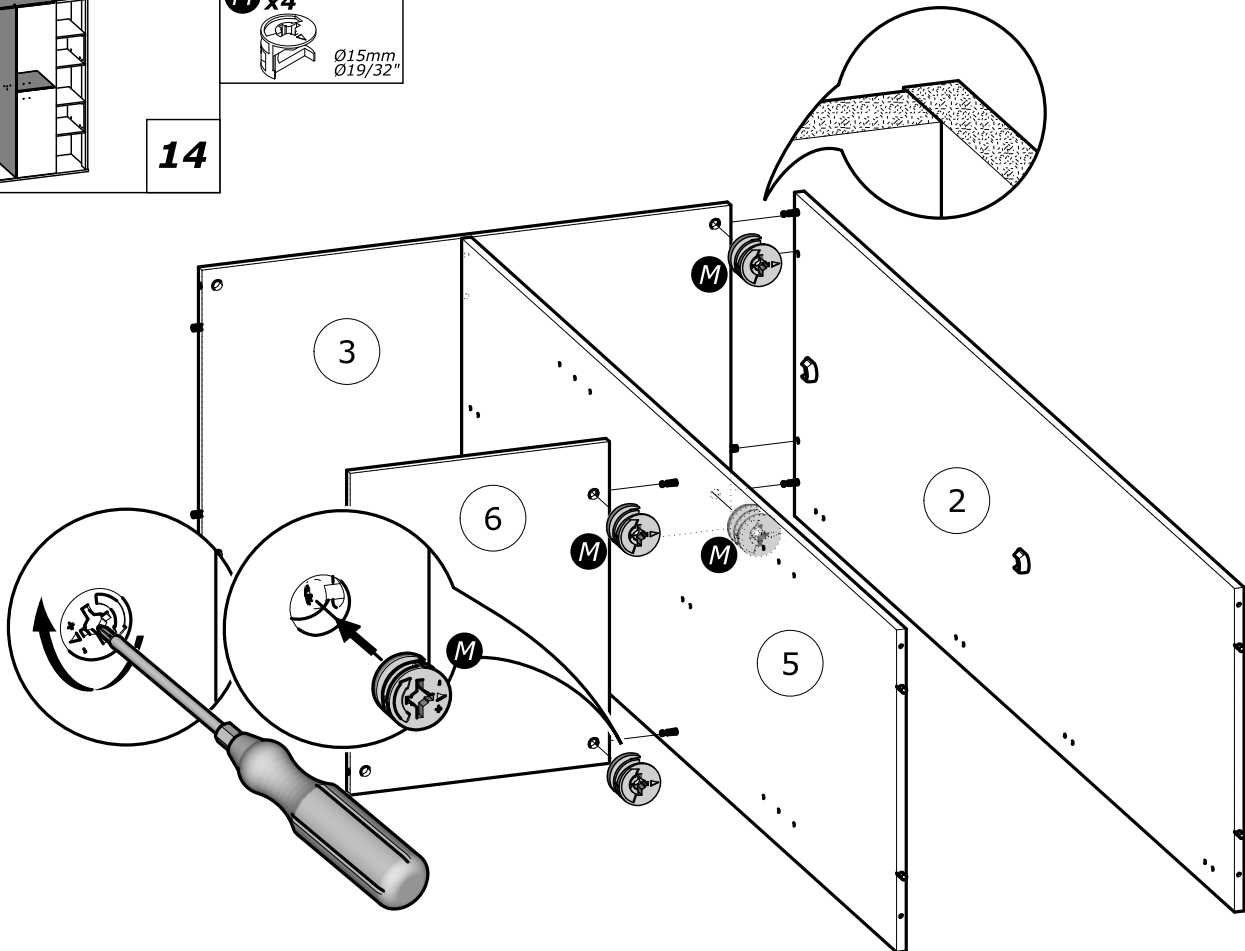
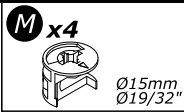

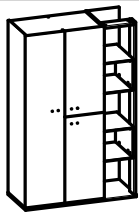

15

**M** x4  
Ø15mm  
Ø19/32"

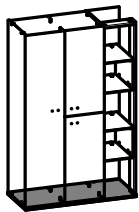
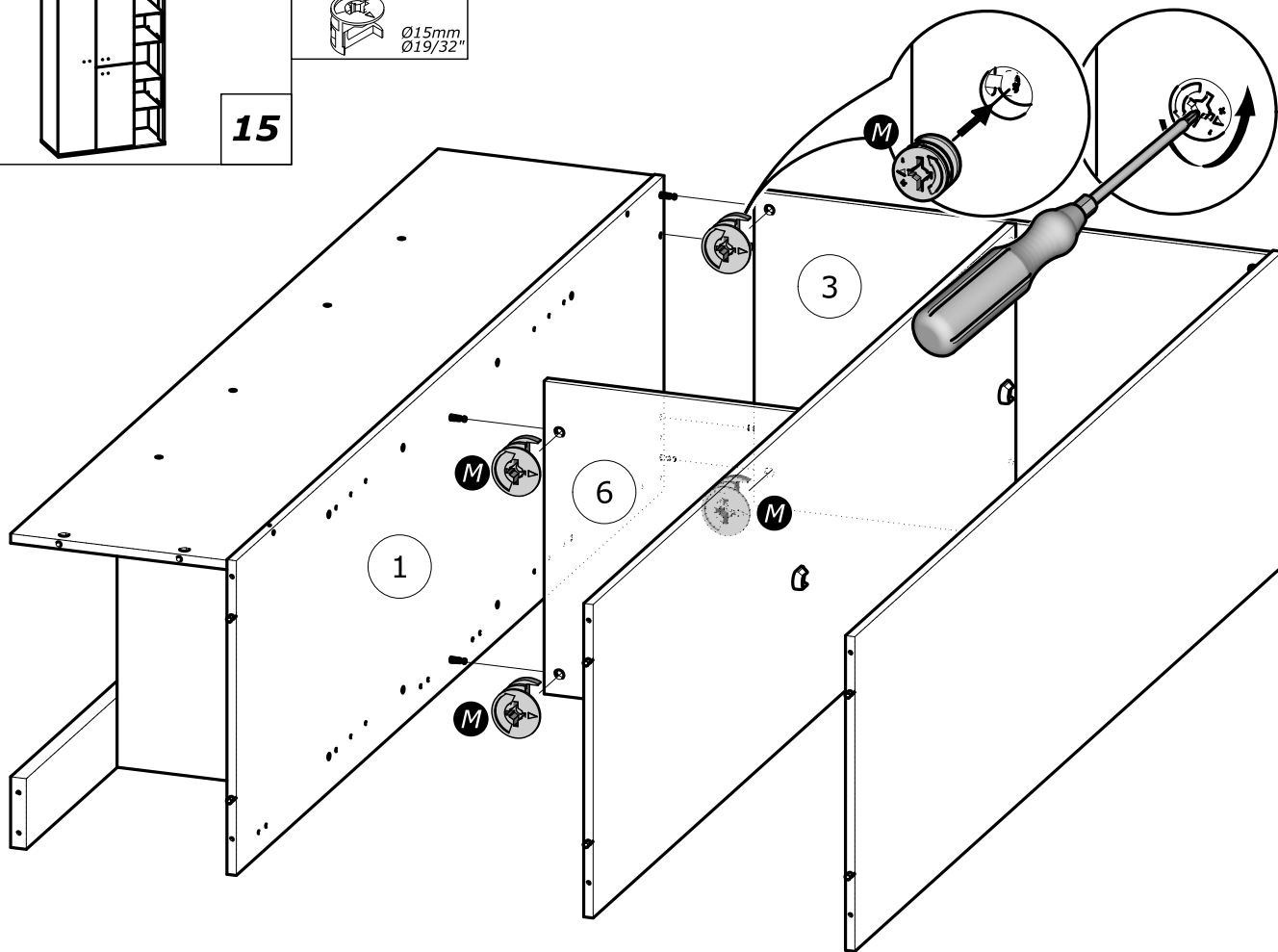

16

**L** x2

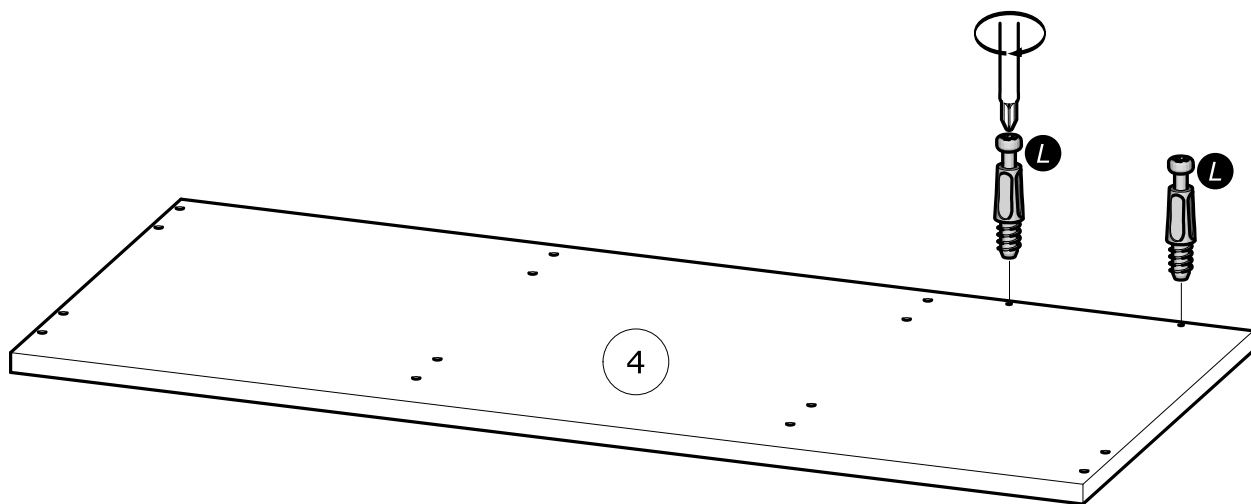

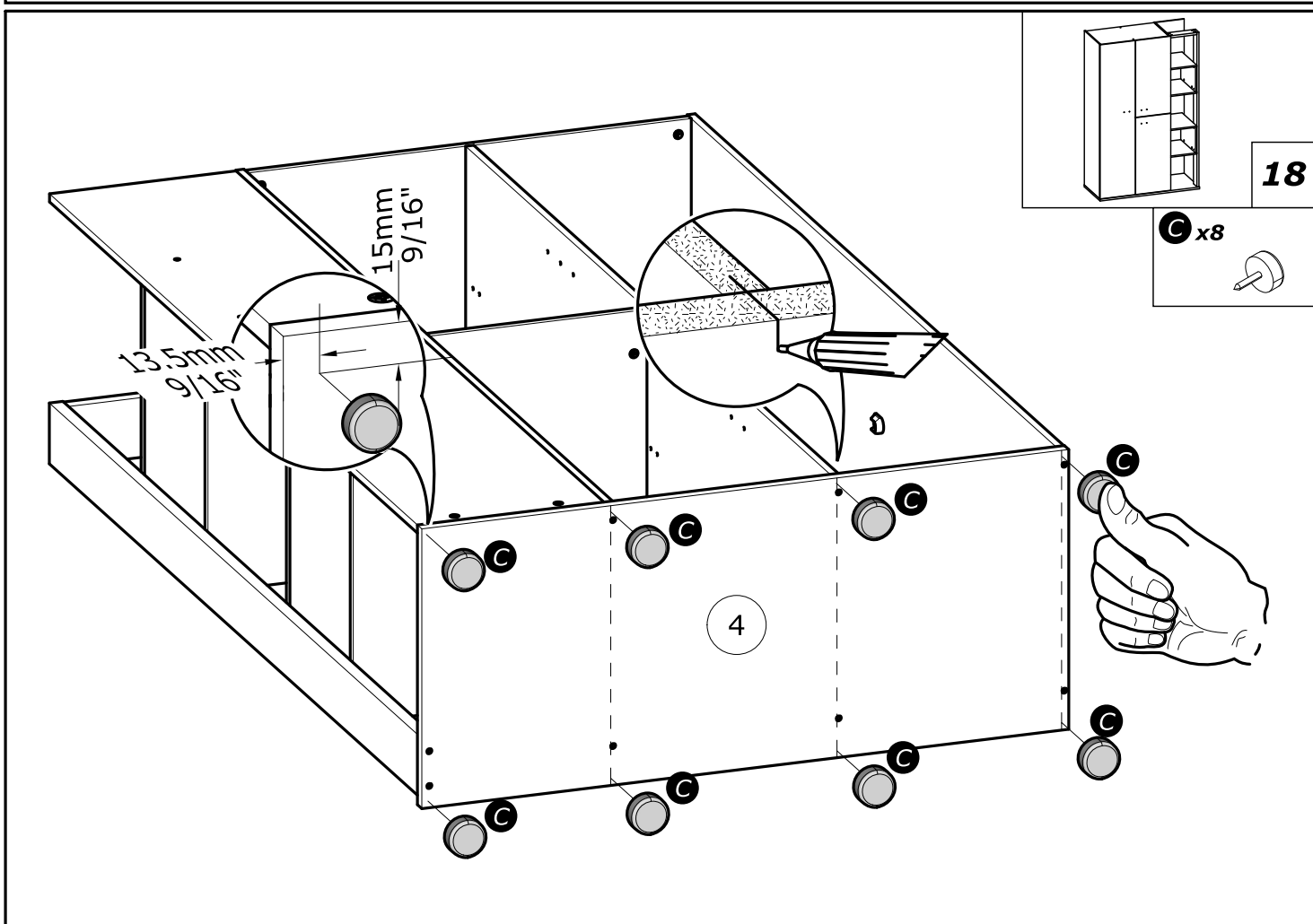
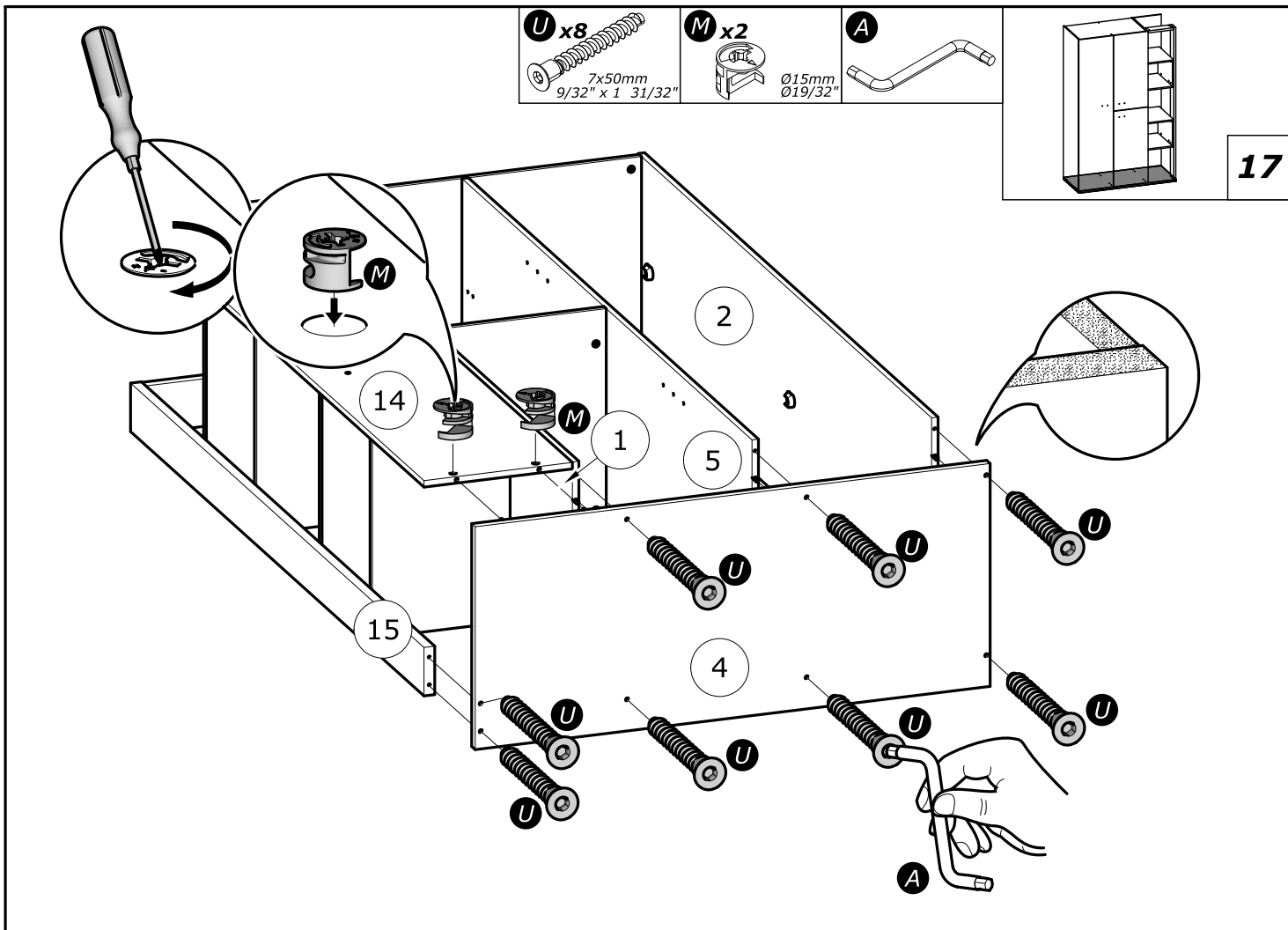

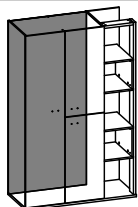

19

P

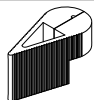

V x41

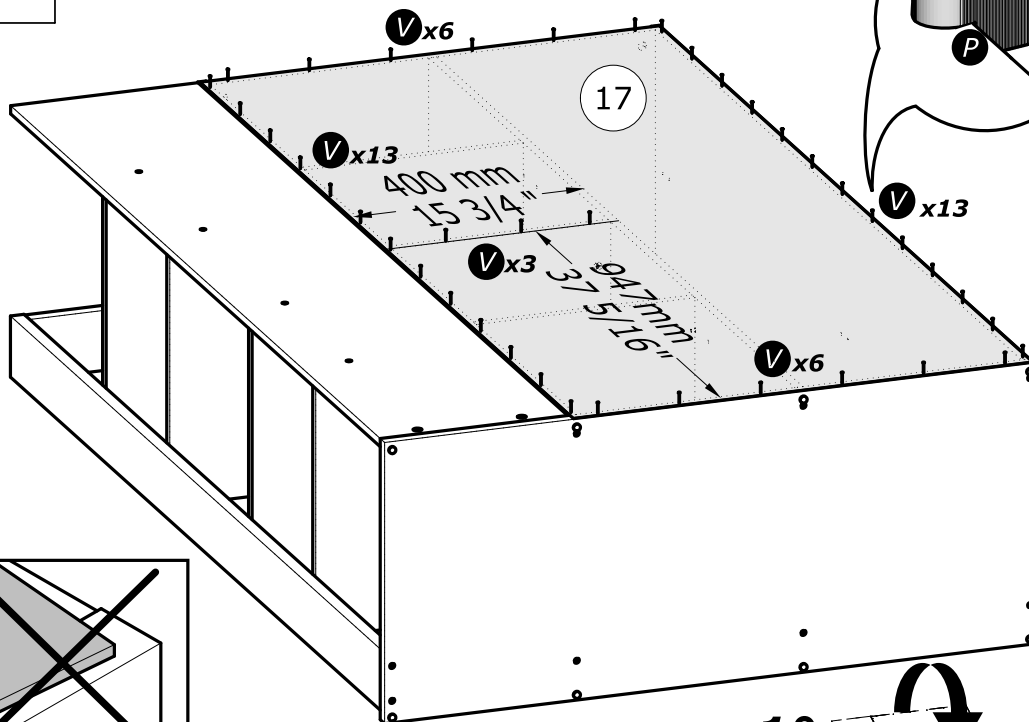
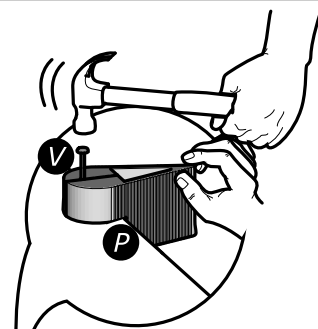

www.Demeyere.fr

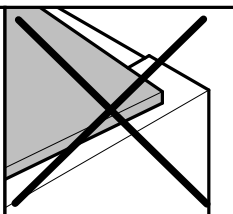
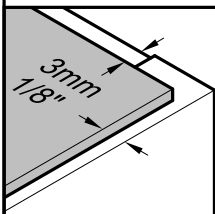

1°

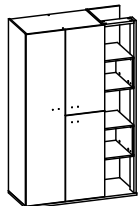
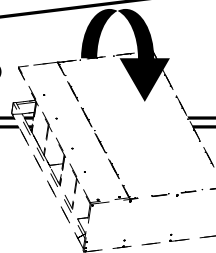

20

J x2

3.5x15mm  
1/8" x 19/32"

S x2

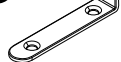

1°

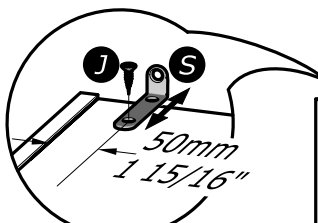

2°

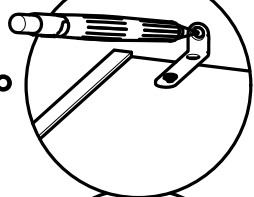

3°

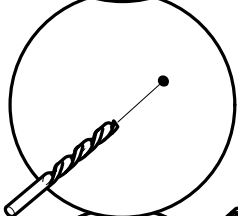

4°

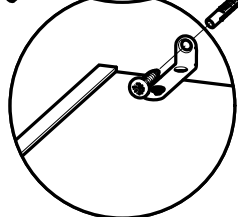

2°

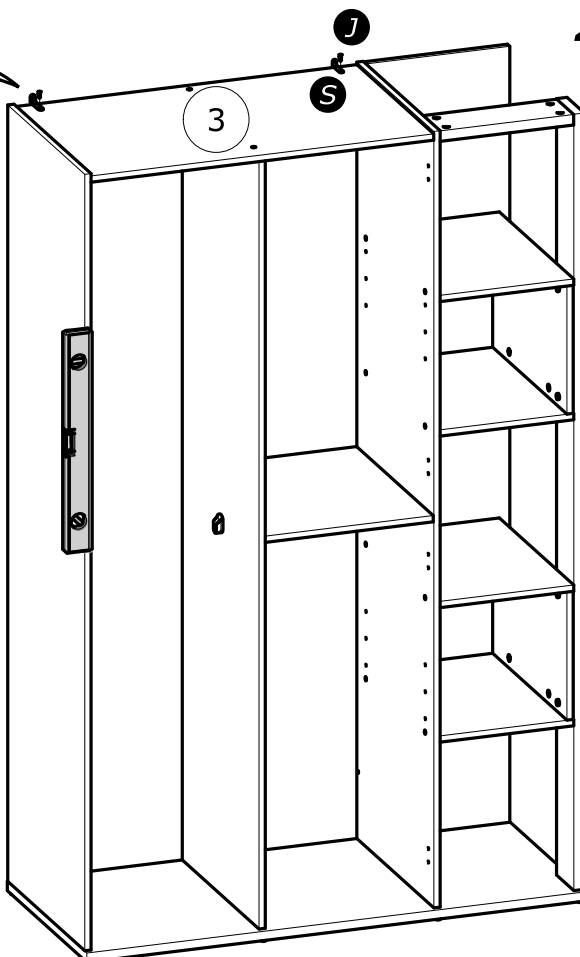
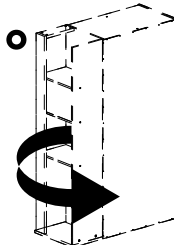

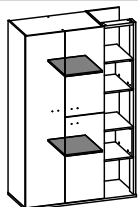

21

**D** x8



**T** x8

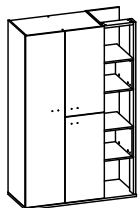
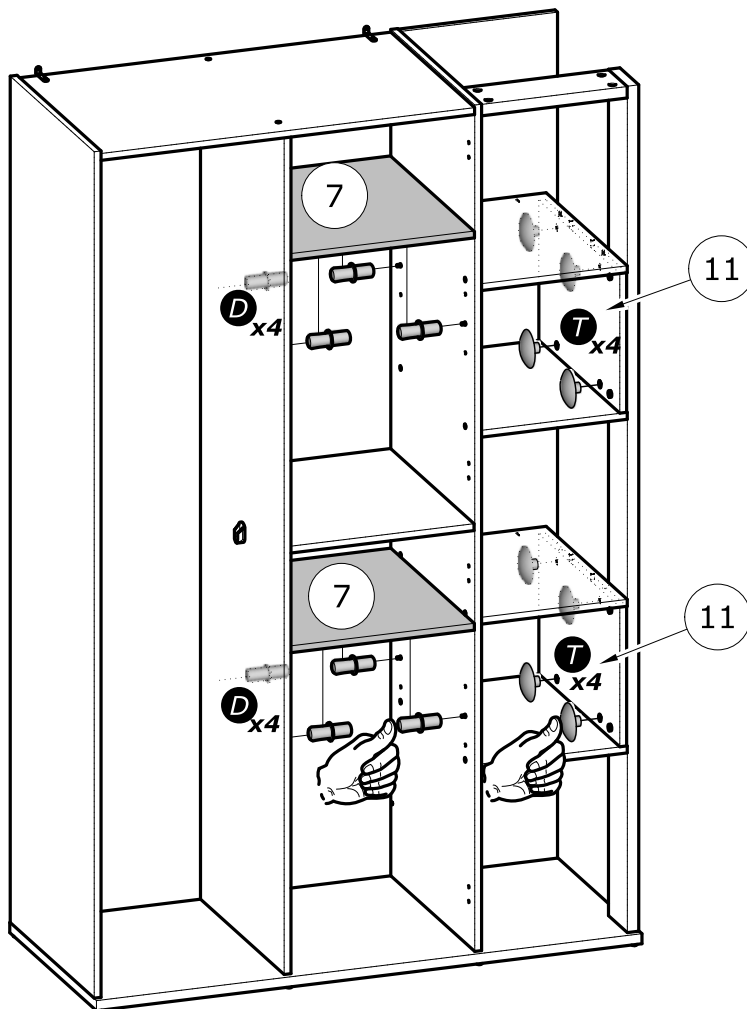
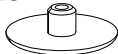

22

**K** x2

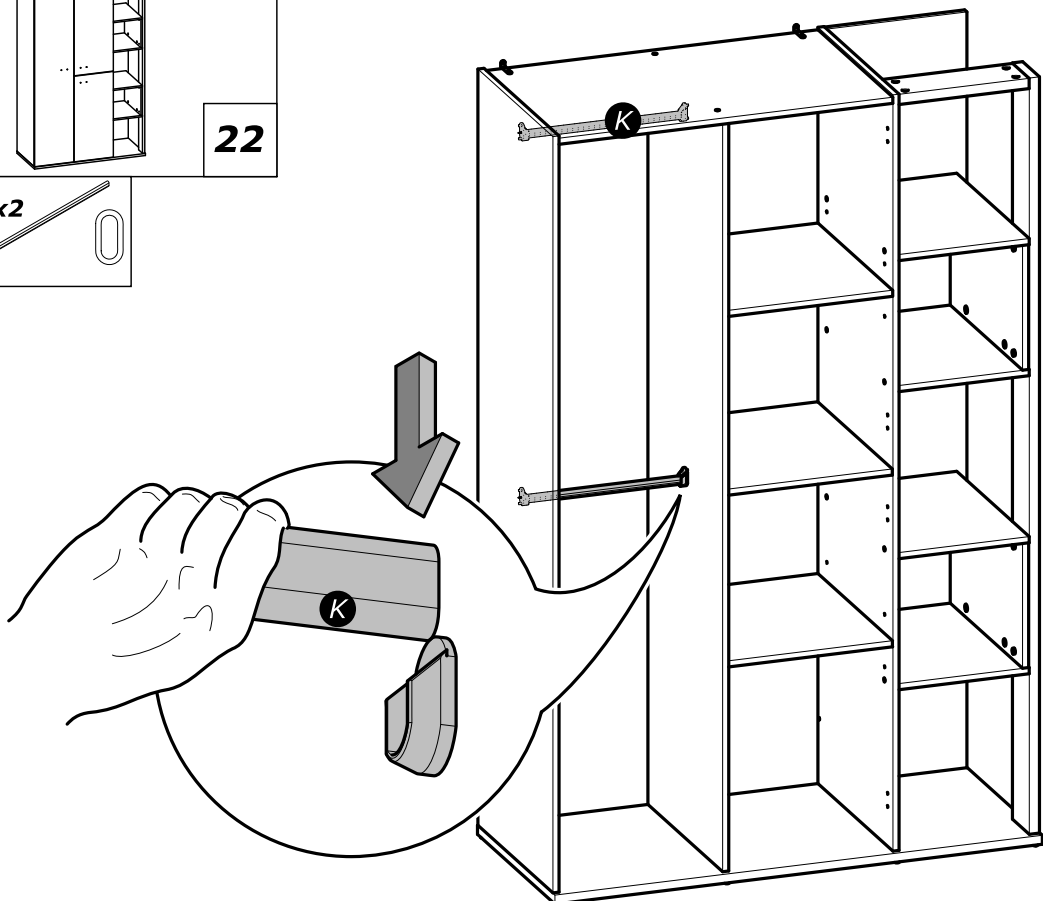

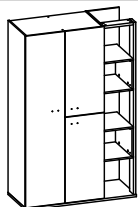

23

**Q** x8

H=2mm  
H=1/16"

**R** x8

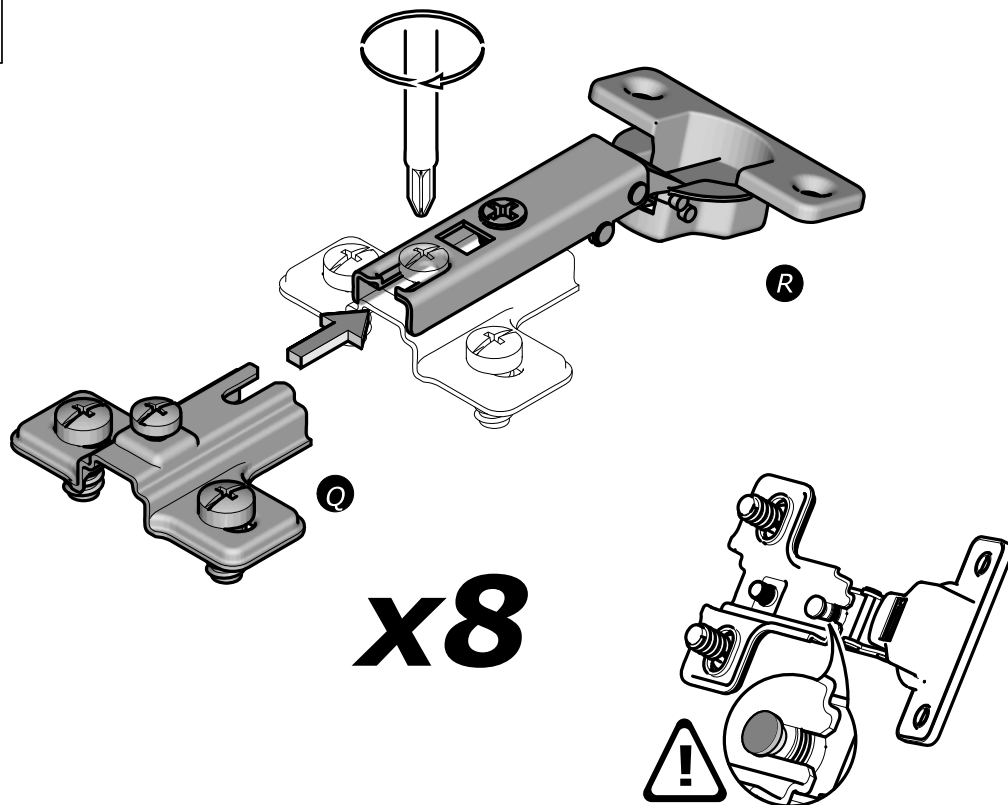

**x8**



[www.Demeyere.fr](http://www.Demeyere.fr)

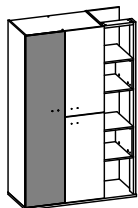

24

**J** x8

3.5x15mm  
1/8" x 19/32"

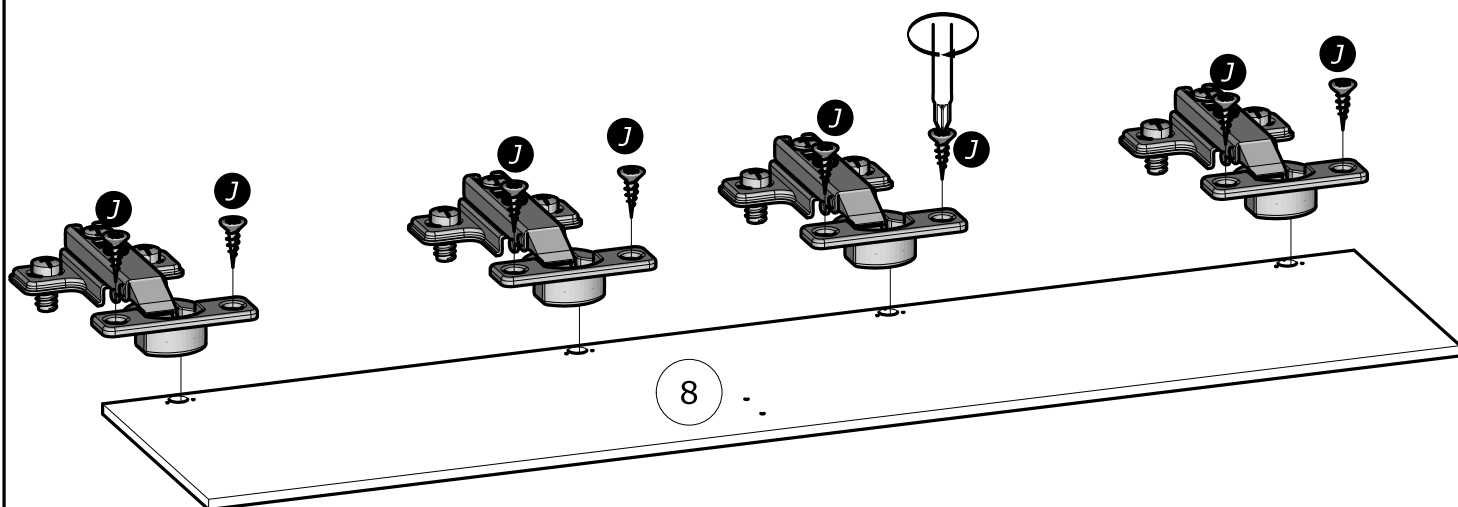

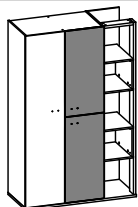

25

**J** x8

3.5x15mm  
1/8" x 19/32"

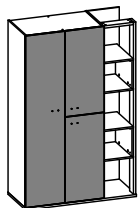
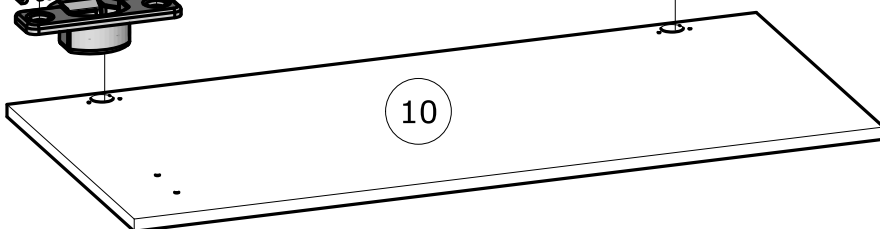
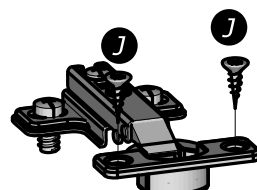
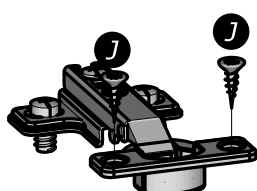
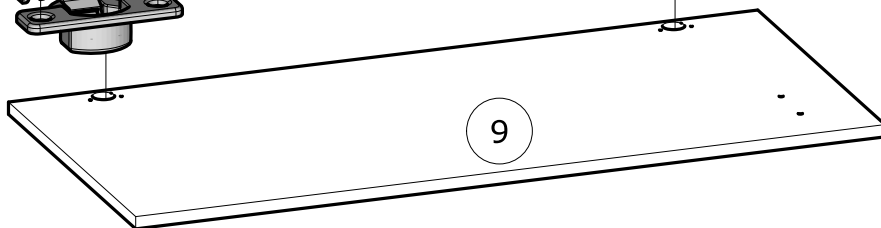
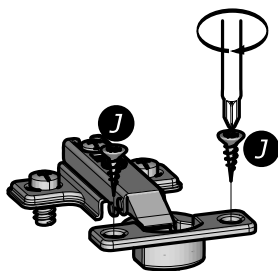
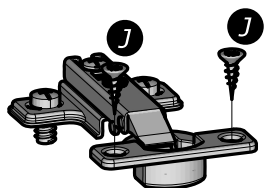

26

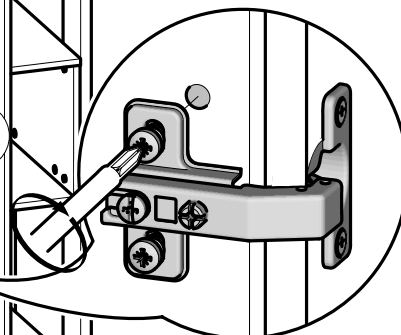
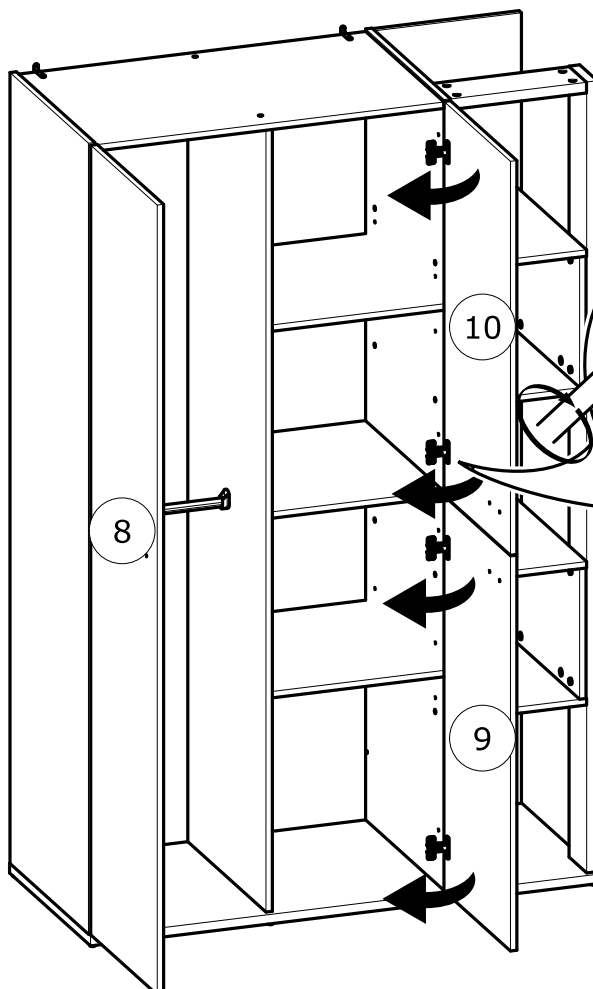

**x8**

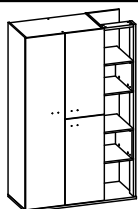

27

**F** x6  
4x25mm  
5/32" x 1"

**N** x3

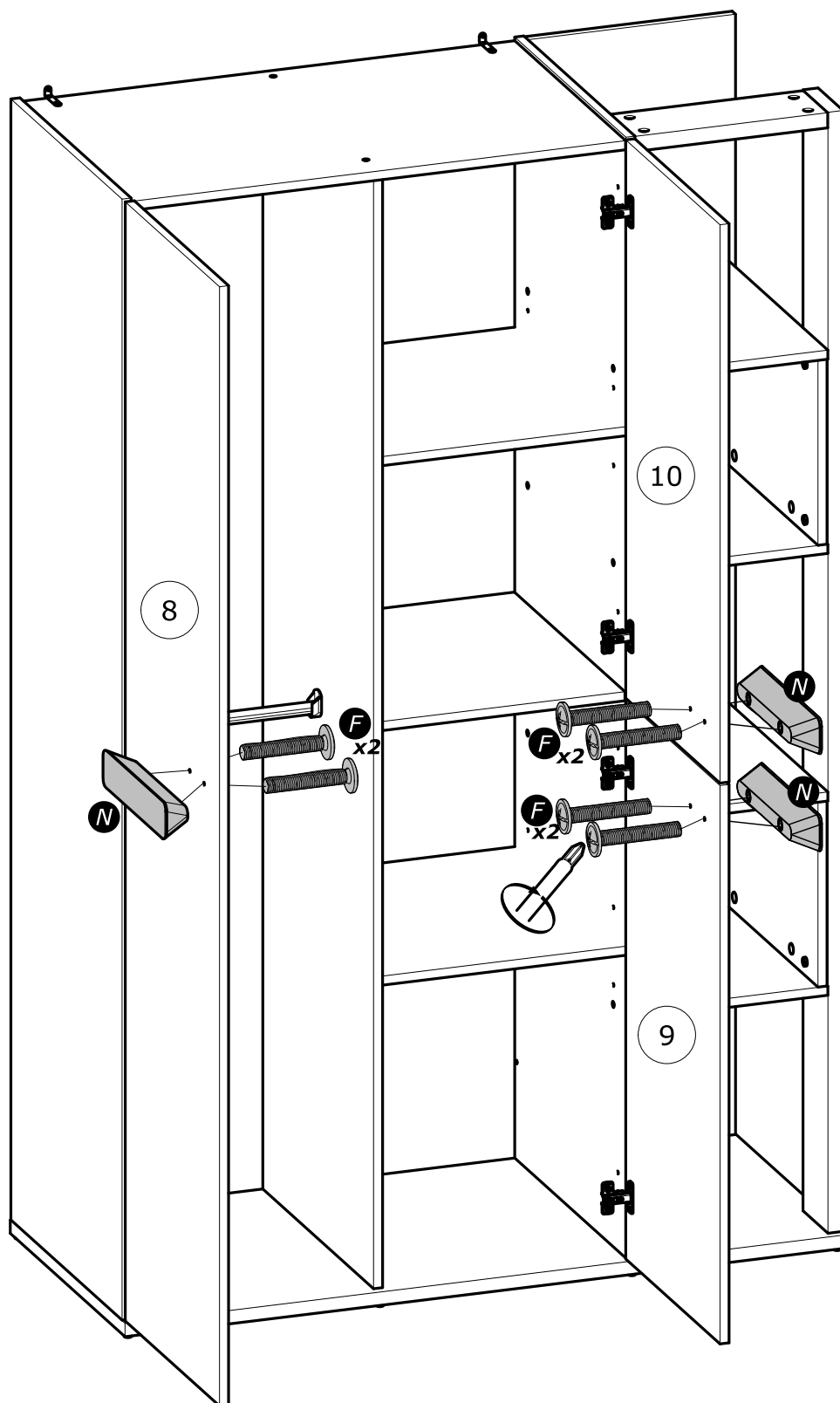

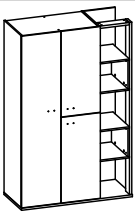

28



[www.Demeyere.fr](http://www.Demeyere.fr)

