

Assembly Instructions

CHAIR

CAUTION: You must read this before you proceed

Please look in the Seat frame for hardware packs

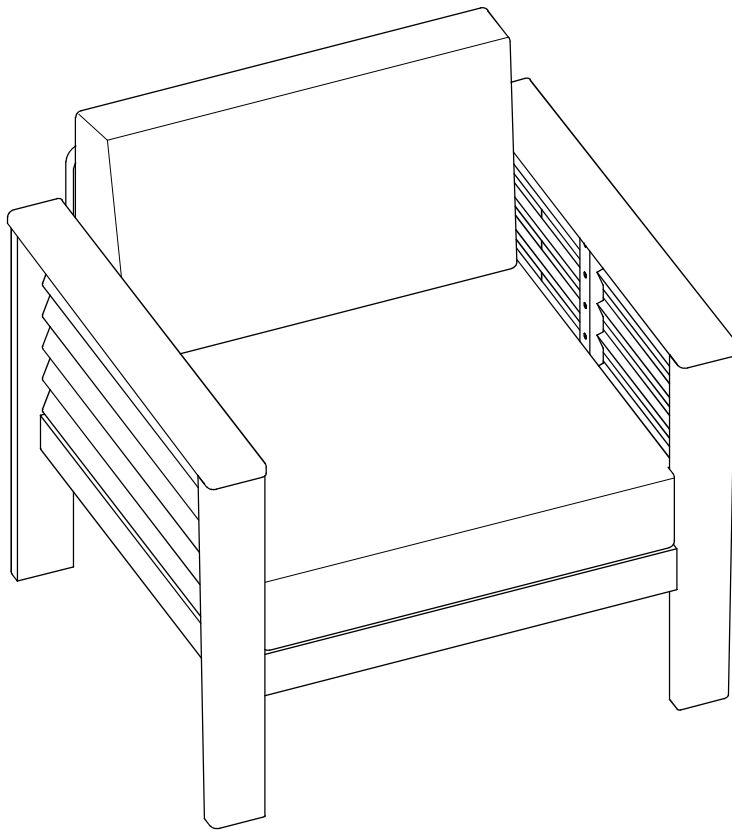

CAUTION: This Chair is NOT a TOY.

Keep your child/children at bay during the assembly process.

Whenever lifting the Chair and to prevent any possible damage to it, two adults are needed to execute this action.

Parts List

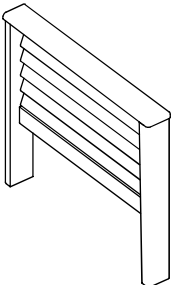
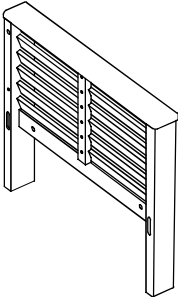
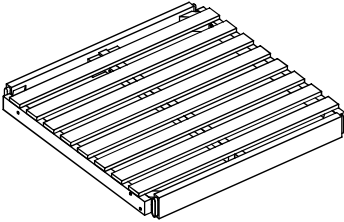
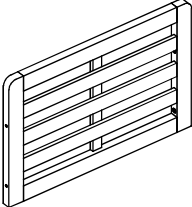
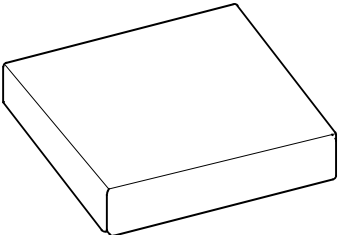
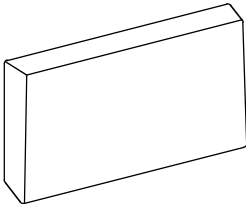
No.	Picture	Description	Qty
A	 A line drawing of a rectangular panel with four horizontal slats, attached to a vertical leg on the right side.	Left Leg Panel	1
B	 A line drawing of a rectangular panel with four horizontal slats, attached to a vertical leg on the left side.	Right Leg Panel	1
C	 A line drawing of a rectangular panel with seven horizontal slats.	Seat Panel	1
D	 A line drawing of a rectangular panel with five horizontal slats, featuring a curved top edge.	Backrest	1
E	 A line drawing of a rectangular cushion with a slightly raised edge.	Seat Cushion	1
F	 A line drawing of a rectangular cushion.	Back Cushion	1

Hardware

Table Hardware

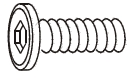
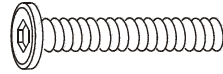
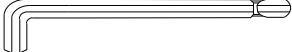
No.	Picture	Description	Qty
①		Bolt (M6 x 35mm)	7
②		Bolt (M6 x 65mm)	5
③		Allen Wrench	1

Assembly Preparation

Before Beginning Assembly:

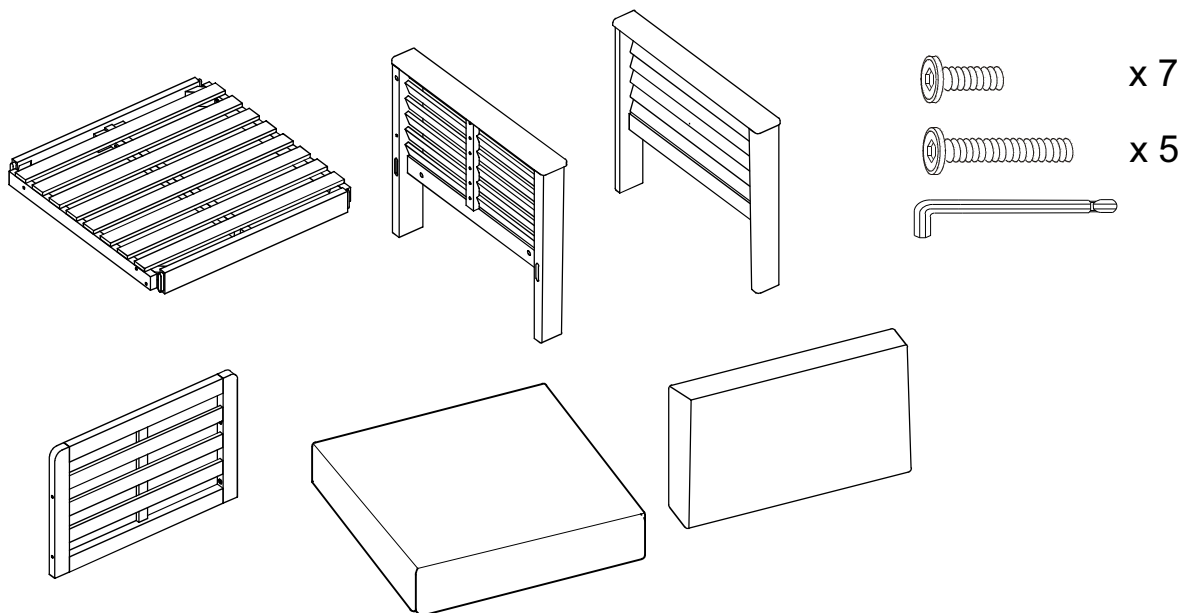

Read instructions, cover to cover.



Have 2 adults on hand for assembly.



Do not assemble on flooring or carpet.



Assemble on a clean non-marring surface (packing foam).



Save all packaging until finished.

Assembly Steps

OVERVIEW

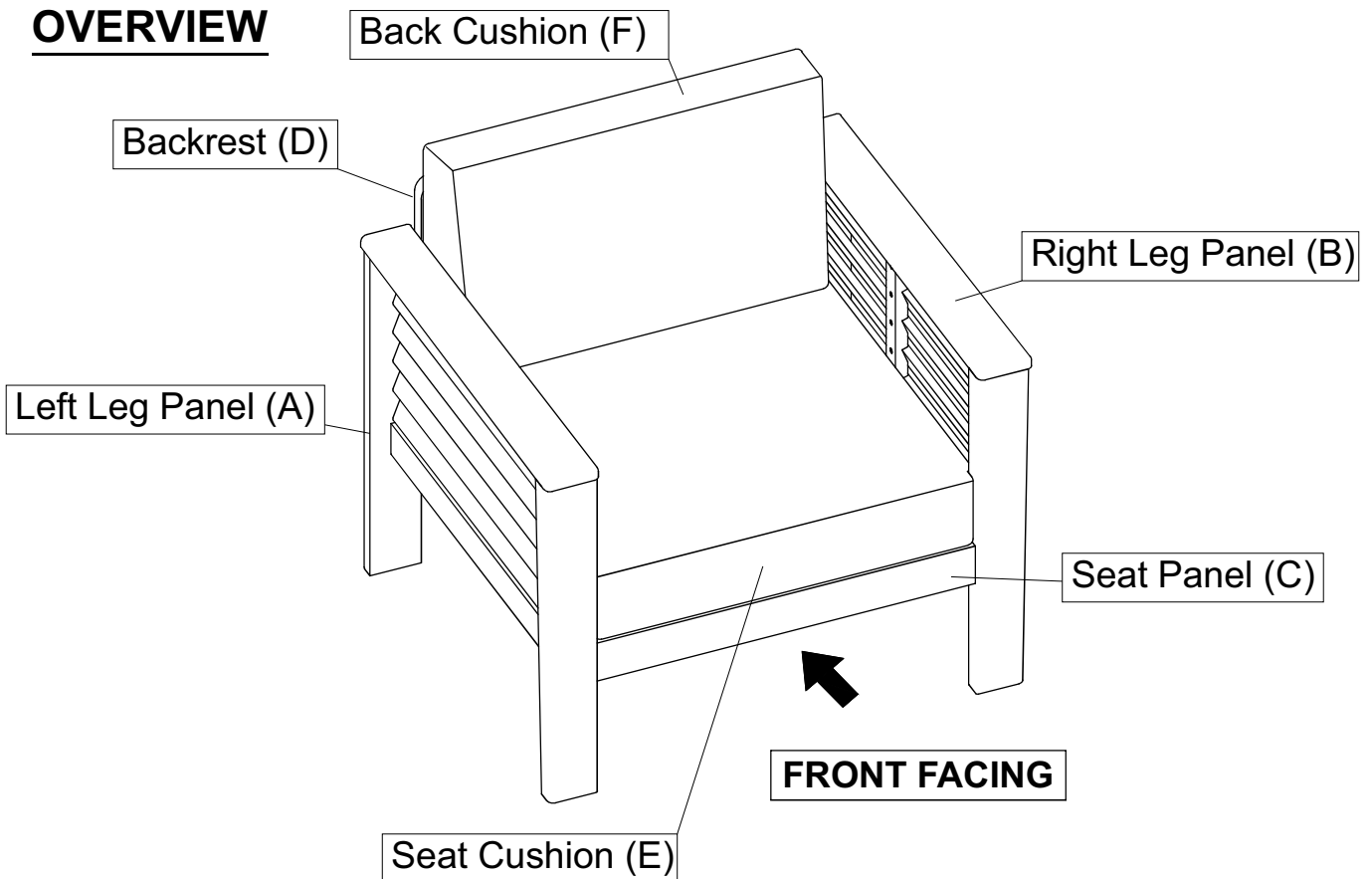

This Chair has multiple parts and may require up to 30 minutes to assemble. To give you an overview of the Chair parts, the above picture is to help you put the various parts into perspective. Please read through the instructions below to familiarise yourself with the parts and steps before assembly.

Step 1

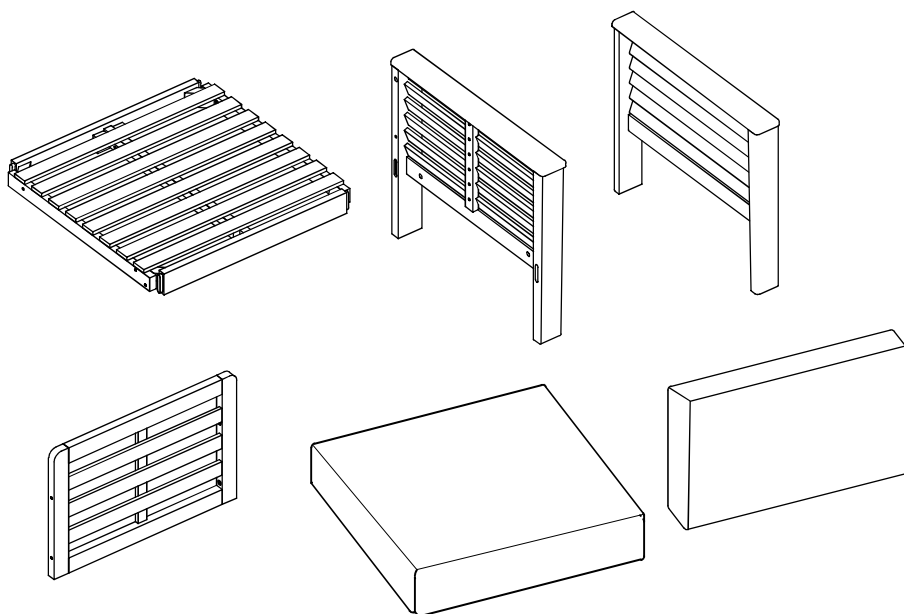

Unpack and place all parts on a clean, non-marring surface.

Assembly Steps

Step 2

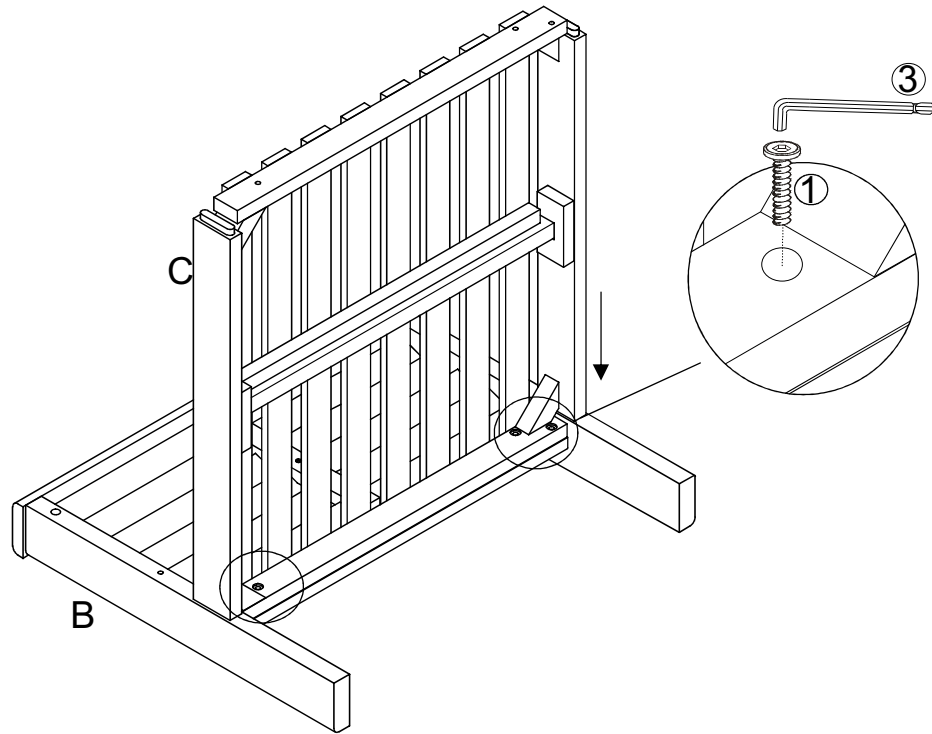

Place the Right Leg Panel (B) on a clean, non-marring surface, Then attach the Seat Panel (C) to the Right Leg Panel (B) using Bolts (①) and Allen Wrench (③).
Do not fully tighten the Bolts.

Step 3

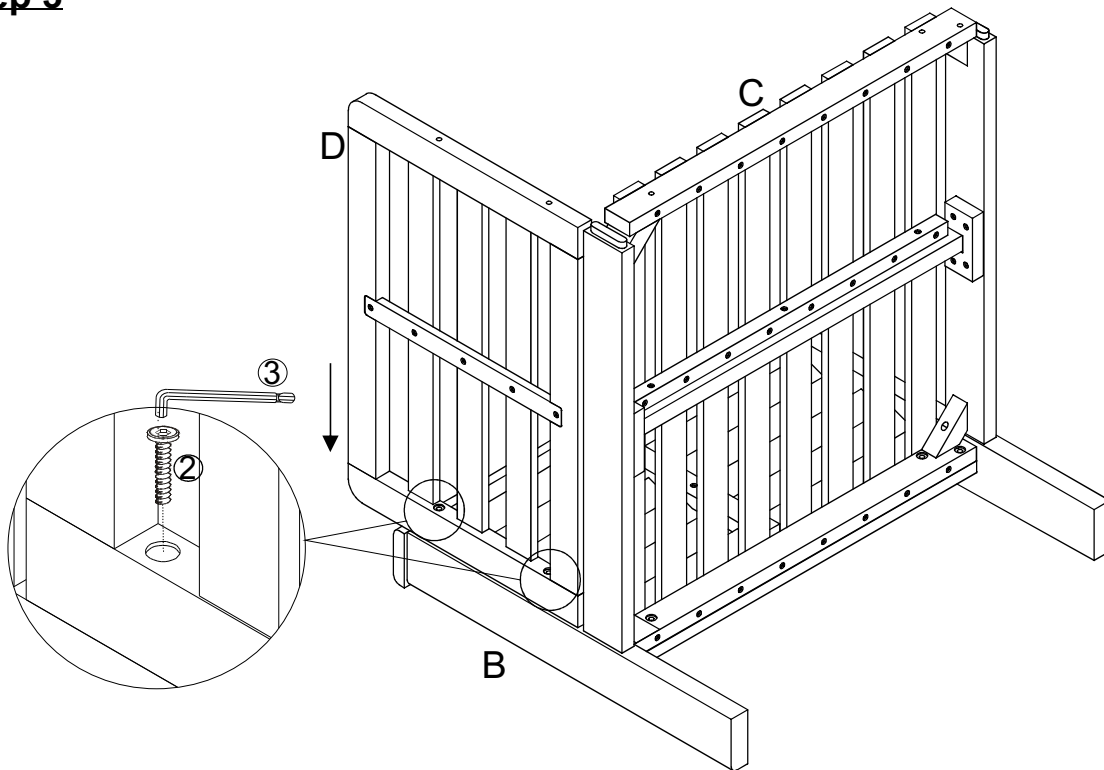

Attach the Backrest Panel (D) to the Right Leg Panel (B) of assemble in step 2 using Bolts (②) and Allen Wrench (③) as shown above.
Do not fully tighten the Bolts.

Assembly Steps

Step 4

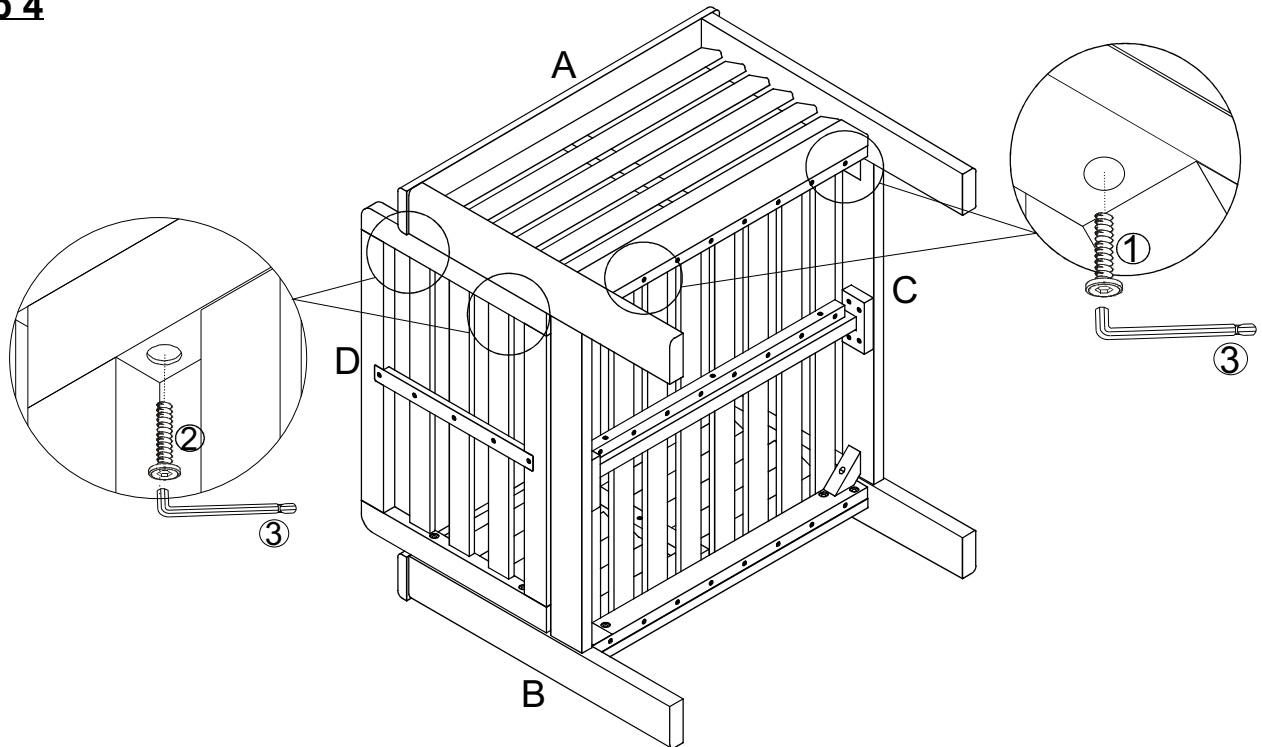

Attach the Left Leg Panel (A) to the Seat Panel (C) and Backrest Panel (D) of assemble in step 3 using Bolts (①), Bolt (②) and Allen Wrench (③) as show in above picture.

Do not fully tighten the Bolts.

Step 5

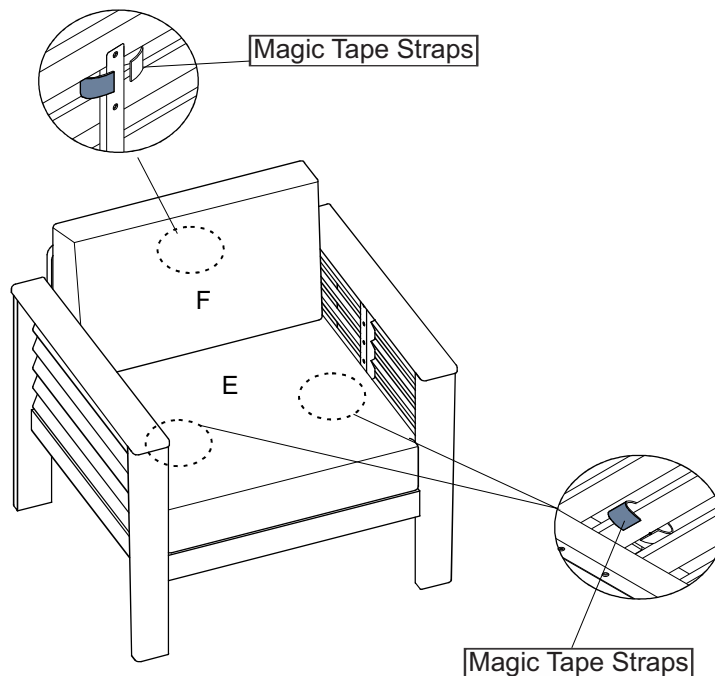

With the assistance of your adult partner, stand the Chair up.

Place Seat Cushion (E) on to Seat Panel (D). Stick the magic tape straps of Seat Cushion (E) to Seat Panel (D).

Place Back Cushion (F) on to Backrest Panel (F). Stick the magic tape straps of Back Cushion (F) to the Backrest Panel (C). As show in above picture.

Assembly Steps

Step 6

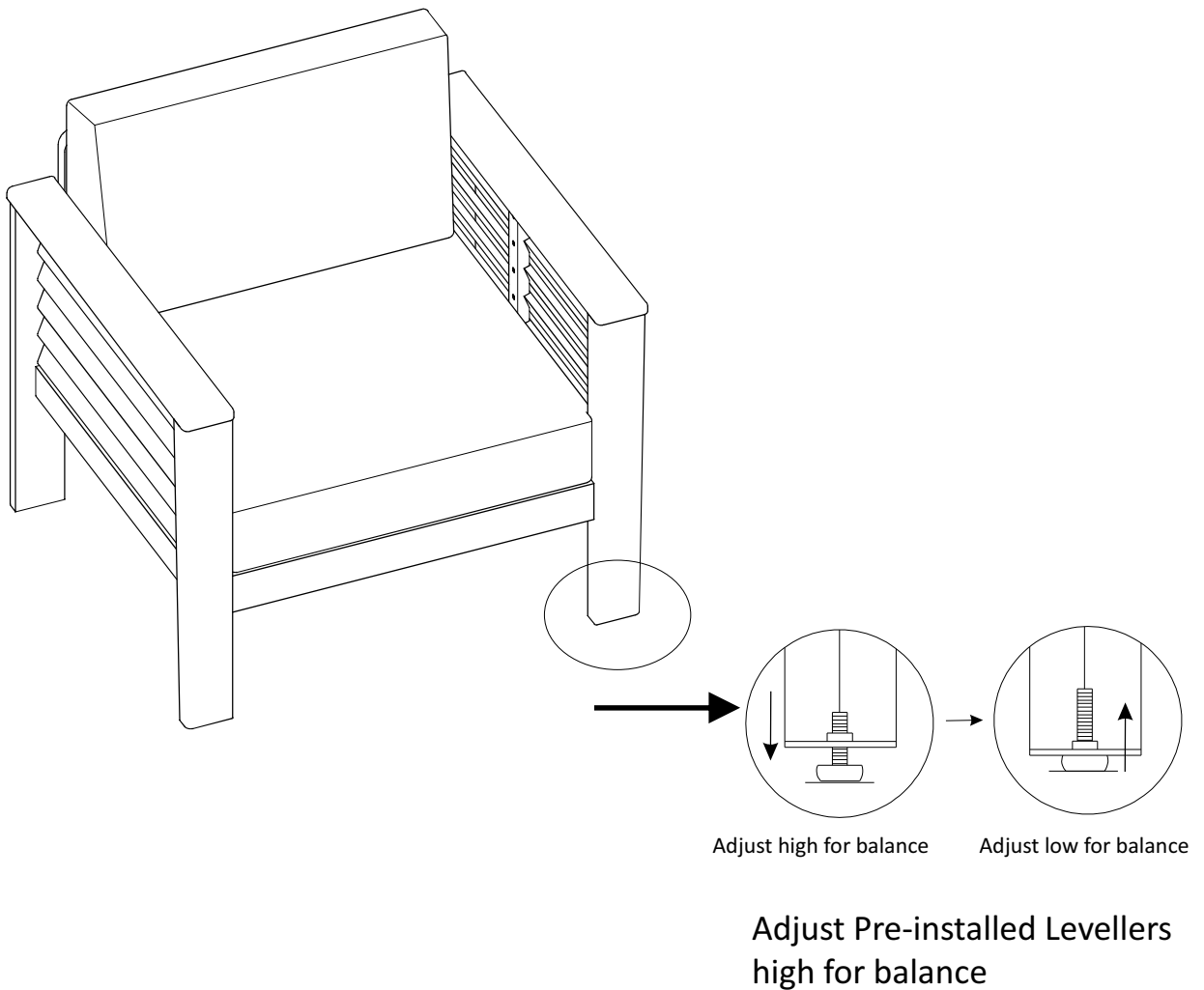

Place the Chair onto a flat, level surface.

Then EXERT pressure, floorwards onto the Chair with both hands.

This pressure will help the Chair reach full alignment at all joints.

In a sequential manner, gradually tighten all Bolts at all joints until evenly secured.

Inspect the Chair and make sure all parts are adequately connected.









Adjust the Levellers until the Chair is level with the ground.

To adjust the Levellers, get assistance from an adult partner to lift/lean and hold the Chair while you are working.

Your Chair is ready for use.

This Chair can only be used on a flat, level surface.

Care & Maintenance

-  Do not put hot items directly on furniture surface.
-  Do not clean furniture with harsh cleansers or polish.
-  To obtain the longest lifespan of your outdoor products, minimizing exposure to direct sunlight is recommended.
-  Children should not climb or jump on the furniture.
-  Do not write on furniture without a padded barrier to protect the surface.
-  To obtain the longest lifespan of your outdoor products, avoid extended and lengthy exposure to rain, snow, and direct sunshine. Whenever possible cover the product and /or place under patio or awnings.
-  Not for commercial use. For residential use only
-  Stains may be removed with mild soap solution and damp cloth.
-  Dust and pick-up spills using a clean, non-colored, lint-free cloth.