













ASSEMBLY INSTRUCTION

PARTS			
1		CHAIR BACK	1PC
2		SEAT	1PC
3		FRONT LEG	2PCS
4		SIDE STRETCHER	2PCS
5		FRONT STRETCHER	1PCS

HARDWARE LIST			
A		Ø5/16" * 22mm	9PCS
B		Ø5/16"	9PCS
C		Ø5/16" * 3-1/2"	4PCS
D		Ø5/16" * 2-1/4"	5PCS
E		4mm	1PC
F		Ø10 * 30mm	2PCS
G		Ø8 * 1-3/4"	6PCS

STEP 1

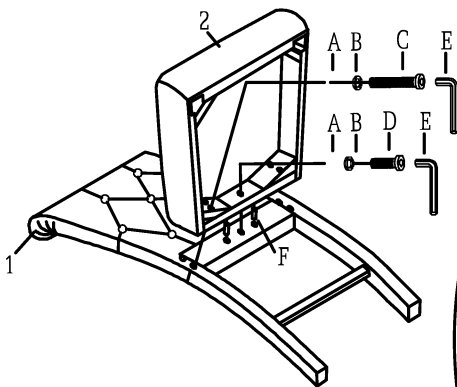

STEP 2

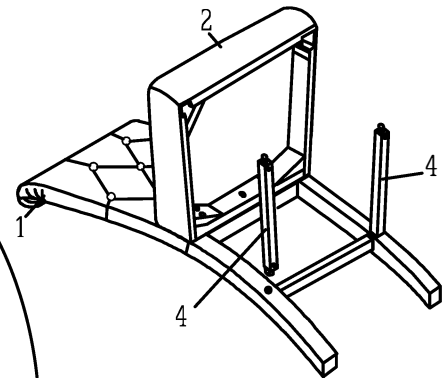
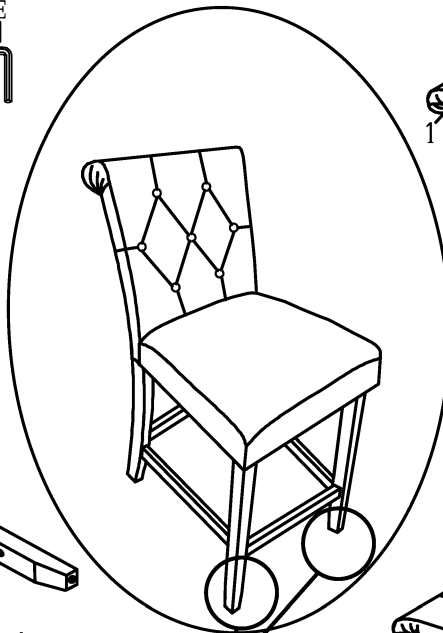

STEP 3

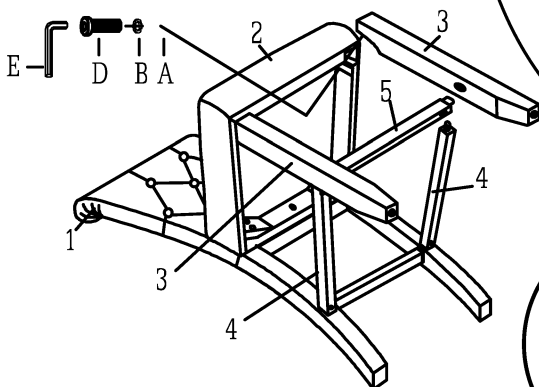

STEP 4

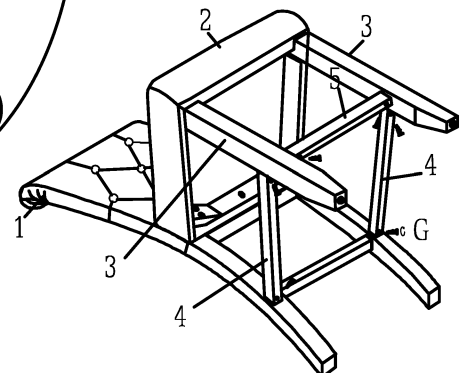

If the chair is not flat after assemble, Please adjust the bottom leveler to keep at the same level.

Do not Tighten ANY Bolts Until All Bolts Have Been Started, Stand the chair Upright on Flat Surface. Put Pressure on the chair and Rock it back and forth to adjust to level, Tighten All Bolts With Allen Wrench.