

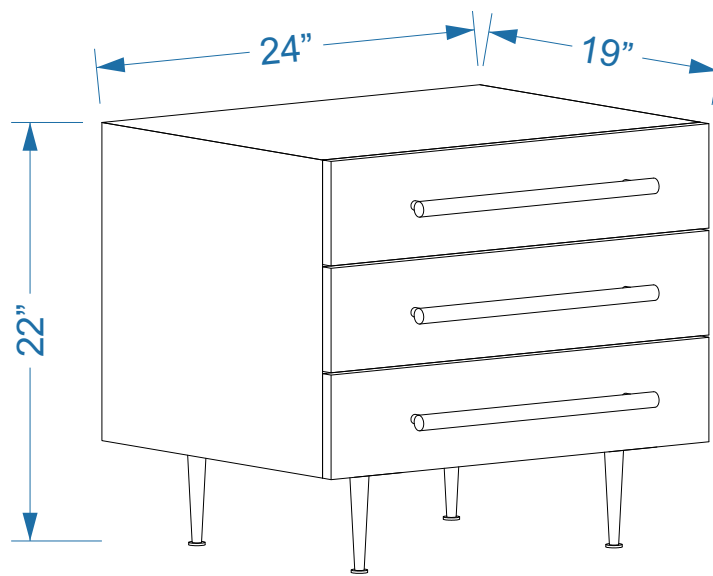

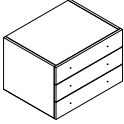

ASSEMBLY INSTRUCTIONS



PARTS LIST

LABEL	PICTURE	DESCRIPTION	QTY
A		BODY	1
B		LEG	4

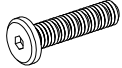
HARDWARE

LABEL	PICTURE	DESCRIPTION	QTY
C		WASHER Ø6/16xH1.5mm	16
D		SCREW M6x20	16
E		WRENCH M4x60	1

BEFORE BEGINNING ASSEMBLY:



Read instructions cover to cover



Have two adults on hand for assembly



Do NOT assemble on flooring or carpet. Assemble on a clean non-marring surface (ex: packing foam)



Save all packaging until assembly is completed

ASSEMBLY STEPS

STEP 1

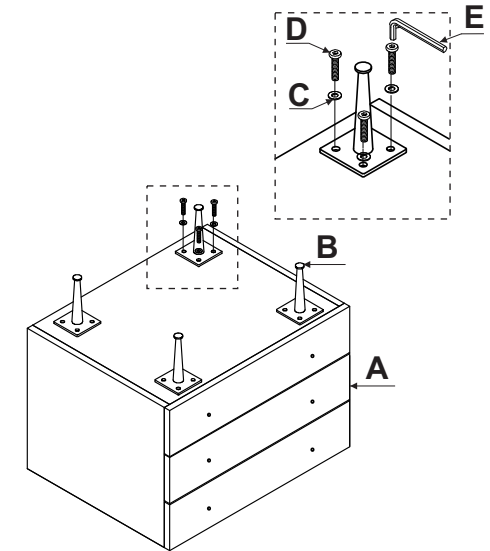
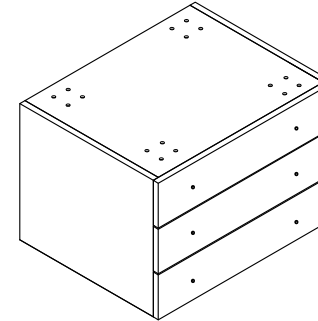

Position the product on its bottom as shown

STEP 2

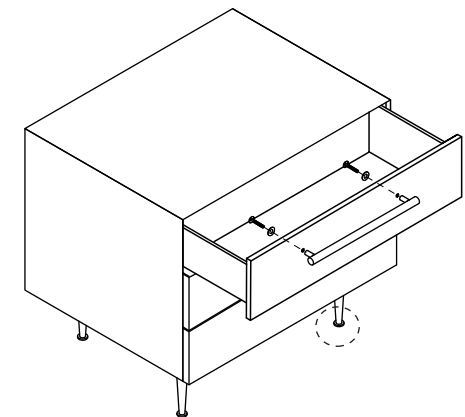
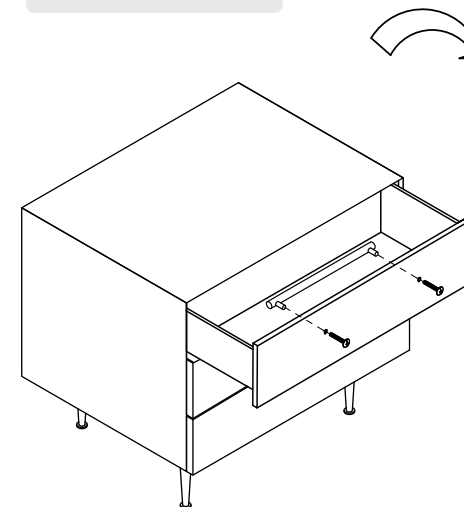

Adjust leveler as needed

