

ASSEMBLY INSTRUCTIONS

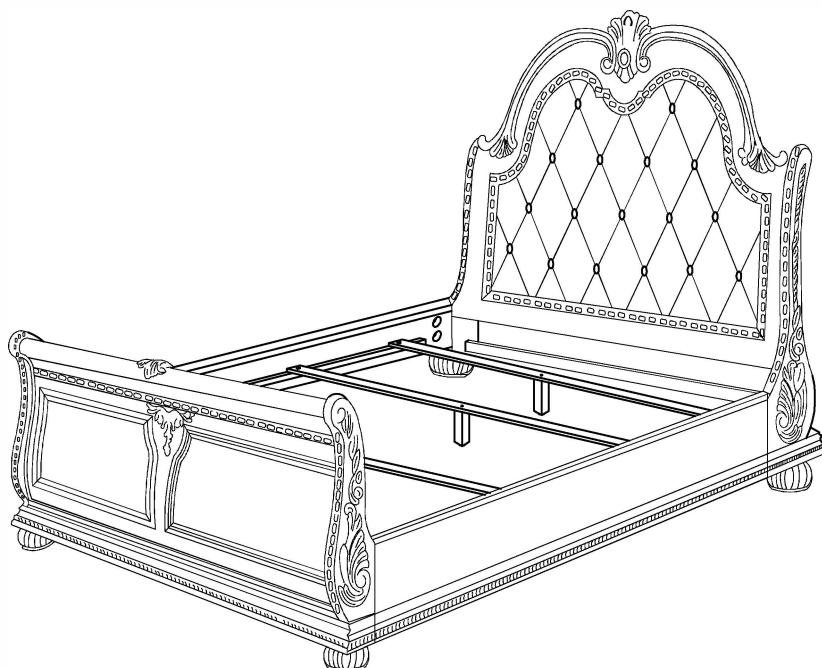

TOOLS REQUIRED



Allen Wrench

(Included)



Phillips
Screwdriver

(Not Included)



Wrench
(Included)



**3 - People
Recommended**

ASSEMBLY RATING



EASY —————> DIFFICULT

The Assembly Rating is a 5-point system showing the level of effort needed to assemble a specific product.

PRE ASSEMBLY INTRODUCTION

We understand building ready-to-assemble furniture can be a challenging experience for some. To help avoid confusion, we have provided some helpful tips that may speed up the process.

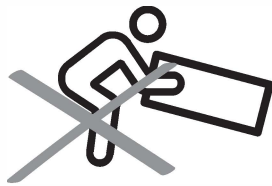

Teamwork

ALWAYS have at least two people to help with transporting and assembling the product to avoid potential injury and/or damage.

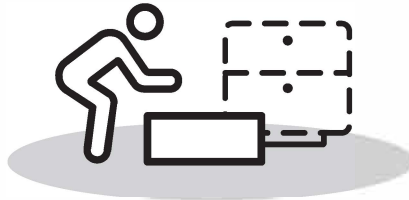
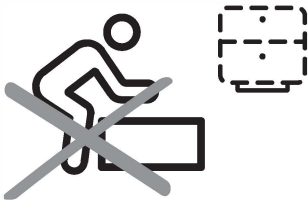

Suitable Location

Assembling near the area of the intended location is highly recommended.



Sufficient Space

Make sure you have enough space to move around during the assembly.



Avoid Scratches

Use cardboard, blankets or a carpeted area while assembling furniture to prevent scratches.

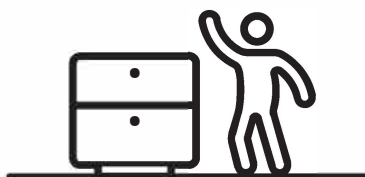

Flat Surface

Make sure the furniture rests on a flat and level surface with each leg evenly touching the floor.

ASSEMBLY AND CARE ADVICE



FAILURE TO FOLLOW THE GUIDELINES BELOW MAY RESULT IN INJURY AND/OR PROPERTY DAMAGE.



Position each part correctly and insert screws or bolts into their respective holes.

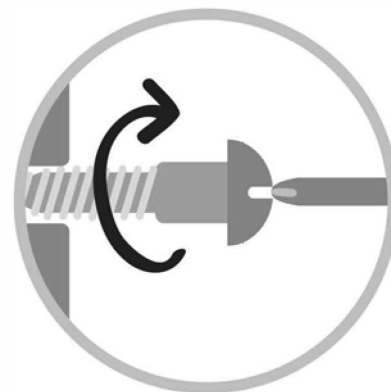

Turn clockwise to tighten and only tighten when step is completed or when instructed to do so.



Use the appropriate hand tools or power tools for assembly. Select steps, such as tightening screws and/or bolts, may require hand tools to avoid causing damage during assembly.



Save the instructions and store any supplied tools for later maintenance.

After two weeks, check and tighten any loose hardware and repeat again every six months thereafter.

IT IS THE USER'S RESPONSIBILITY TO MAINTAIN THE FURNITURE. THE HARDWARE MAY LOOSEN OVER TIME AND MAY CAUSE THE FURNITURE TO BE WOBBLY AND UNABLE TO SUPPORT ITS INTENDED WEIGHT CAPACITY. THIS MAY LEAD TO COLLAPSE AND MAY CAUSE SERIOUS INJURY.

BED

CM7670Q



- Please keep instructions for future reference.
- Check the quantity and irregularity of parts and hardware before you start.

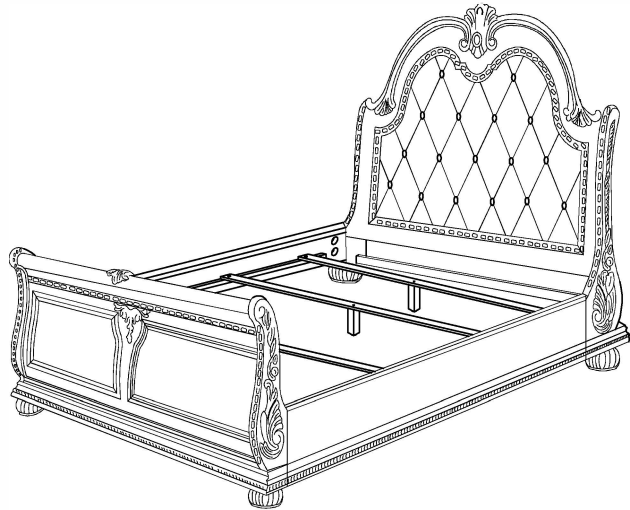

PARTS

#1 1pc

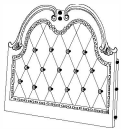

Headboard Panel

#2 2pcs



Headboard Leg
(L&R)

#3 1pc



Footboard

#4 2pcs

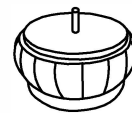

Leg (FB)

#5 2pcs



Side Rail

#6 1pc



Headboard Support

#7 3pcs



Bed Slat

#8 3pcs

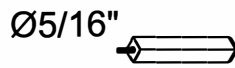

Leg Support
218x30x30mm

#9 x 1pc



Top Flower Of
Headboard

#10 2pcs

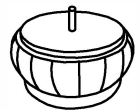

Leg (HB)

HARDWARE

#A 12pcs



Bolt Ø5/16" x 1-3/4"

#B

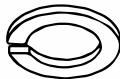

Lock Washer
Ø5/16"

#C 12pcs



Flat Washer
Ø5/16"

#D 1pc



Allen Wrench M4

#E 6pcs



Screw #8 x 32mm

#F 8pcs



Threaded Pins
Ø5/16" x 3-1/2"

#G 8pcs

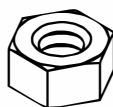

Hex Nut Ø5/16"

#H 8pcs

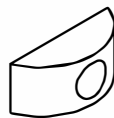















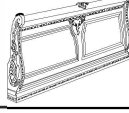

Nut Ø5/16"

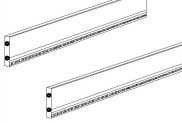
#I 1pc

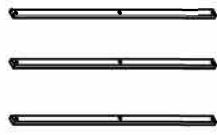
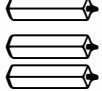

Wrench 14mm

CM7670 Q is packed in 4 cases

Carton	Disignation	Part		Hardware
CM7670 Q-1	Headboard Panel	#1		 #A12pcs  #B12pcs  #C12pcs  #D 1pc
	Headboard Support	#6		
	Top Flower Of Headboard	#9		
CM7670 Q-2	Footboard	#3		
	Leg	#4		
CM7670 Q-3	Side Rail	#5		 #F 8pcs  #G 8pcs  #H 8pcs  #I 1pc  #E 6 pcs
	Bed Slat	#7		
	Leg Support	#8		
CM7670 Q-4	Headboard Leg(L&R)	#2		
	Leg	#10		

ASSEMBLY INSTRUCTIONS

3

- Part #1 x1pc
- Part #2 x2pcs
- Part #6 x1pc
- Part #9 x1pc
- Hardware #A x12pcs
- Hardware #B x12pcs
- Hardware #C x12pcs

1) Prepare 12 bolt assemblies. Insert lock washer (#B) then flat washer (#C) to bolts (#A). Secure top flower (#9) to headboard (#1) with bolts (#A) by using an Allen wrench (#D).

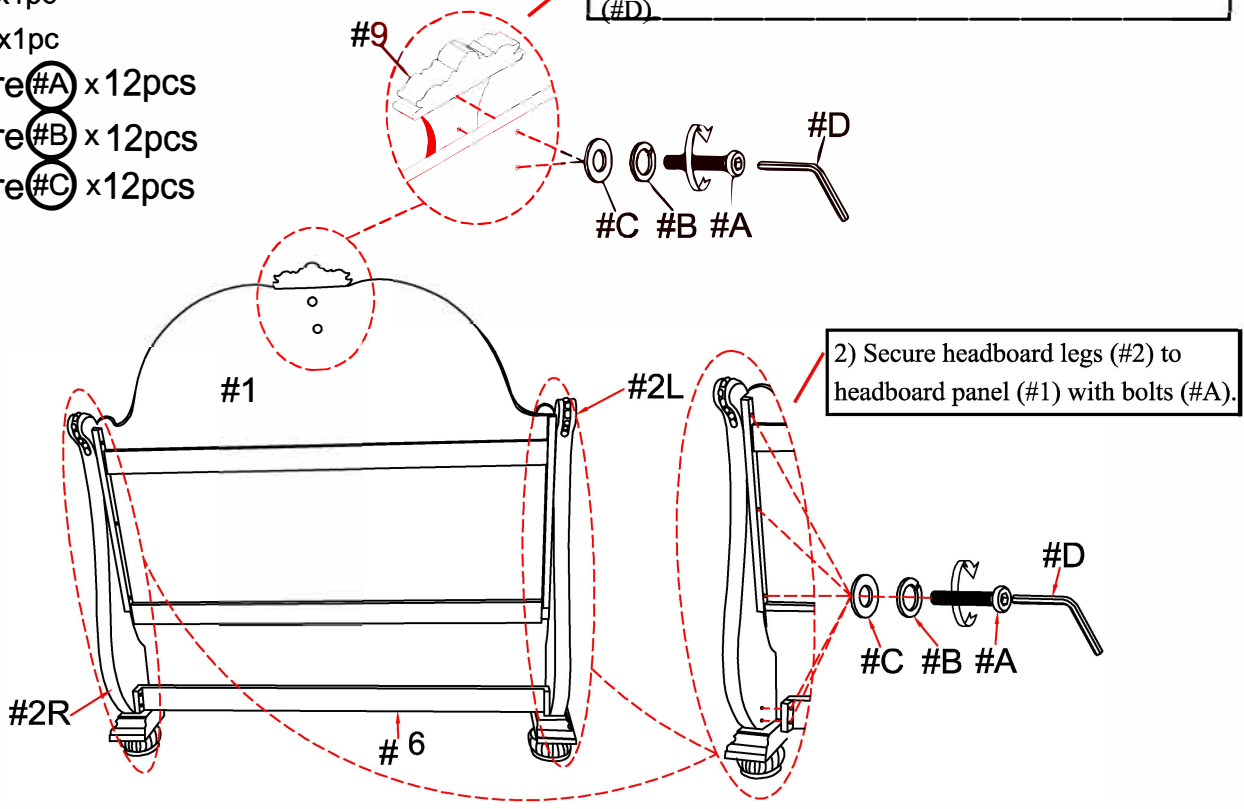

4

- Part #3 x1pc
- Part #4 x2pcs

Attach legs(FB) (#4) to the bottom of the footboard (#3).

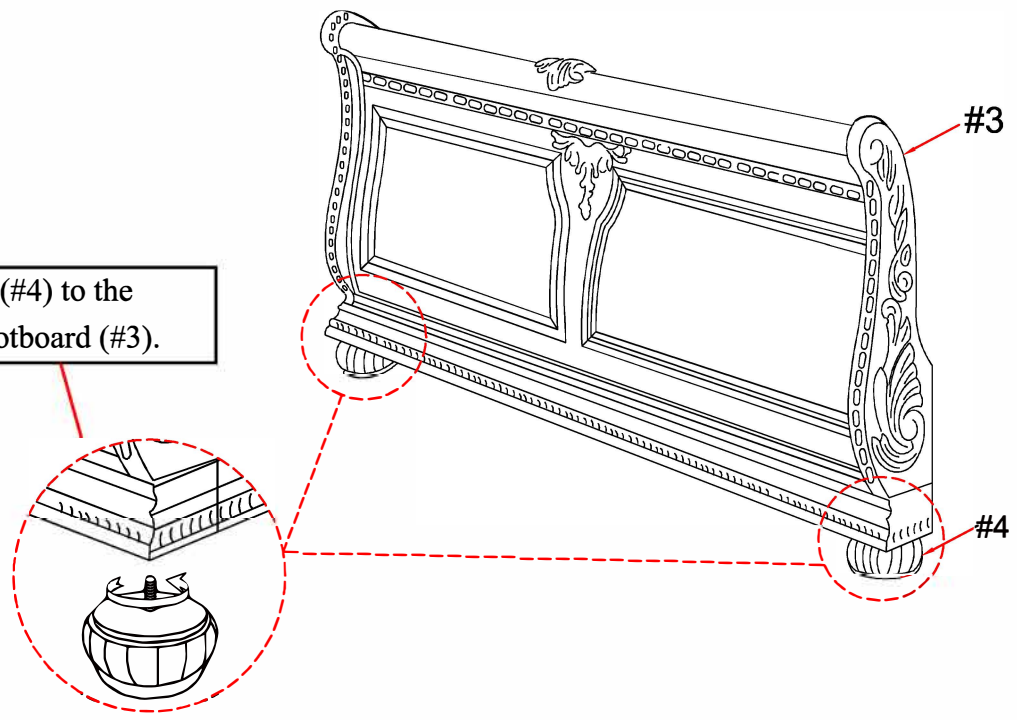

ASSEMBLY INSTRUCTIONS

5

Part #3 x1pc
Part #5 x2pcs

Hardware #F x8pcs
Hardware #G x8pcs
Hardware #H x8pcs

1) Align the side rails (#5) to the holes of the headboard panel (#1) and footboard (#3).

2) Insert Nut (#H) into rails, then use threaded pin (#F) to secure by using hex nut (#G) on the threaded pin (#F).

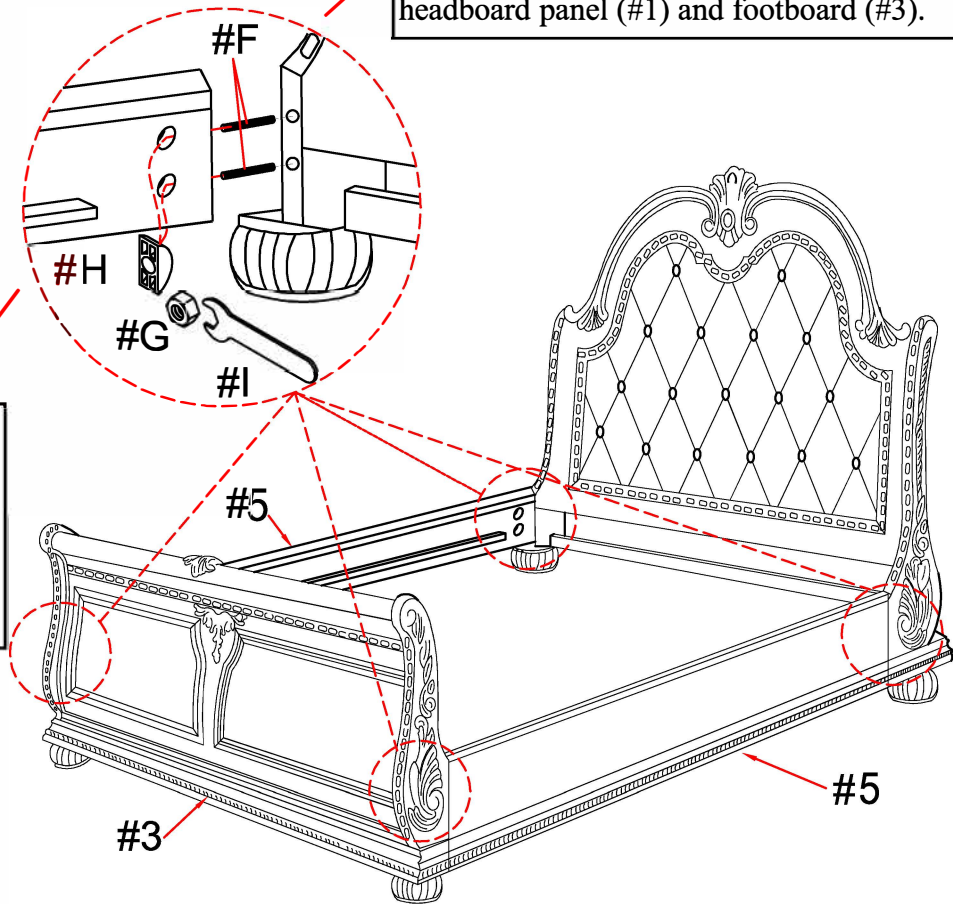

6

Part #7 x3pcs
Part #8 x3pcs

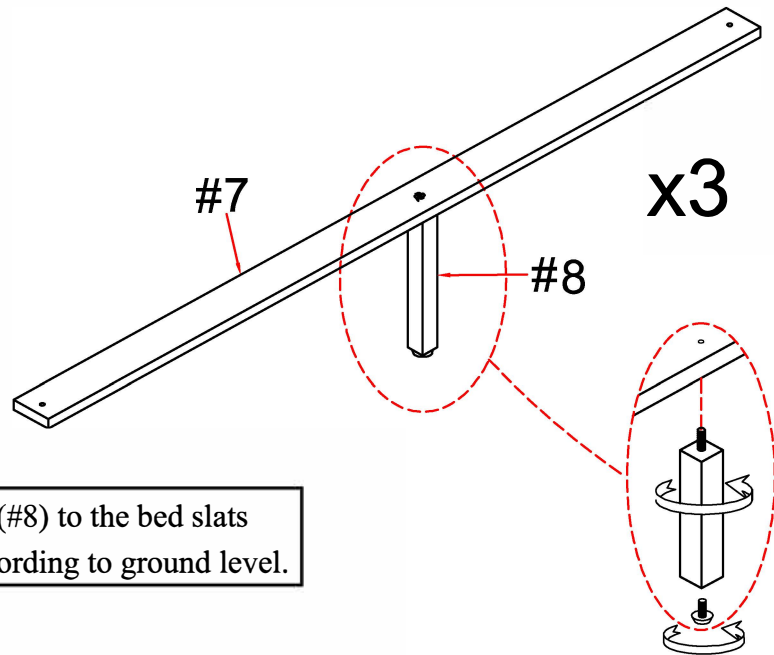

Attach legs support (#8) to the bed slats (#7). Adjust legs according to ground level.

ASSEMBLY INSTRUCTIONS

7

Part #E x8pcs

Align bed slats (#7) to the holes of the side rails (#5), then secure with screws (#E) by using a screwdriver.

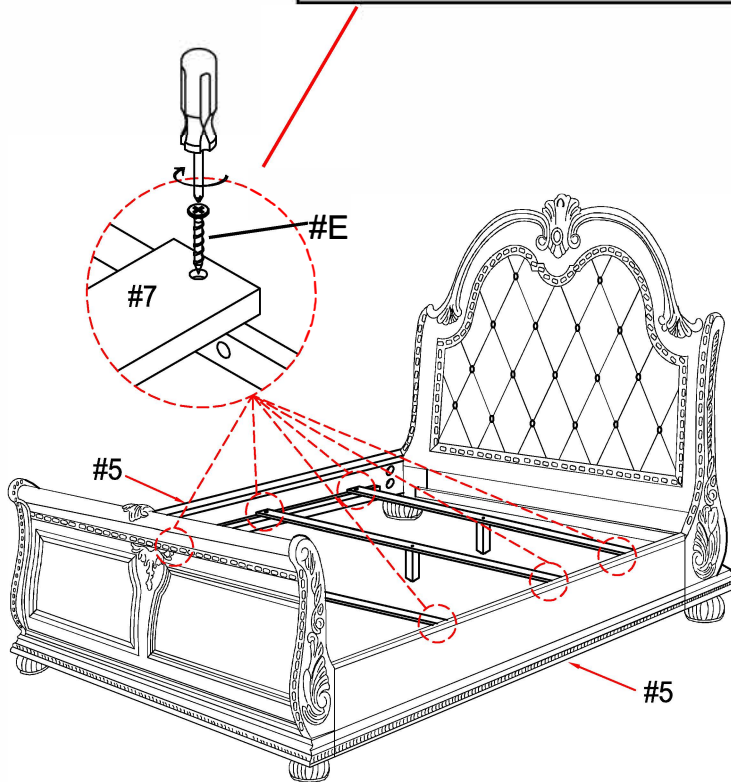

ASSEMBLY COMPLETED



Please ensure the furniture rests on an even and flat surface. If the product wobbles or feels loose, double-check all bolts and/or screws are properly tightened and secured.



Keep this handy!

Please retain this instruction manual and any order-related information for future reference.



Lift, don't drag!

To avoid damage to product please always LIFT the product when transporting or adjusting the placement.