

# Assembly Instructions

**ITEM NO.**

B1424-110 TALCOTT - KING HEADBOARD

B1424-128 TALCOTT - KING FOOTBOARD / S. FRAME / SLATS & LEG











B1424-230 TALCOTT - C.KING SIDE RAILS













B1424-128D TALCOTT - KING STORAGE DRAWER

Thank you for purchasing this quality product. Be sure to check all packing materials carefully for small parts, which may have come loose inside the carton during shipment. Identify and count all items and compare with the parts list and/or hardware list shown below.

Caution : please read the instruction thoroughly before assembly.

1. We recommended that you assemble this product with the assistance of another person, this will make the assembly easier, and will help eliminate damage to the product or injury to persons during assembly.
2. Please do not tighten screws or bolt until the assembly is completed.
3. Please put all parts on a non-abrasive floor before assembly and follow the assembly steps to assemble your newly purchased product correctly and efficiently.

PARTS LIST			
NO.	DESCRIPTION	SKETCH	QTY
A	HEADBOARD		1 pc
B	FOOTBOARD		1 pc
C	SIDE RAIL		2 pcs
D	ROLL-OUT SLAT		1 set
E	CENTER SLAT		1 pc
F	DRAWER TRACK		1 pc
G	DRAWER		2 pcs
H	LONG SLAT SUPPORT LEG		4 pcs
I	SHORT SLAT SUPPORT LEG		2 pcs
J	DRAWER TRACK SUPPORT LEG		2 pcs
K	RAIL CAP		2 pcs

HARDWARE LIST			
NO.	DESCRIPTION	SKETCH	QTY
1	JCBB - M8 x 25/32"		8 pcs
2	FLAT WASHER - M8 x 23/32"		8 pcs
3	ALLEN KEY - M5		1 pc
4	JCBC - M6 x 1-3/16"		2 pcs
5	SPRING WASHER - M6		14 pcs
6	FLAT WASHER - M6 x 23/32"		2 pcs
7	ALLEN KEY - M4		1 pc
8	PANHEAD - M4 x 1-3/16"		26 pcs
9	AC/DC ADAPTER		1 pc
10	JCBC - M6 x 2"		12 pcs
11	FLAT WASHER - M6 x 1/2"		12 pcs
12	PANHEAD - M4 x 5/8"		5 pcs

**WEIGHT CAPACITY** 800 lbs

**STEP 1** : Assembly the Drawer Track Support Leg (J) to the Drawer Track (F).

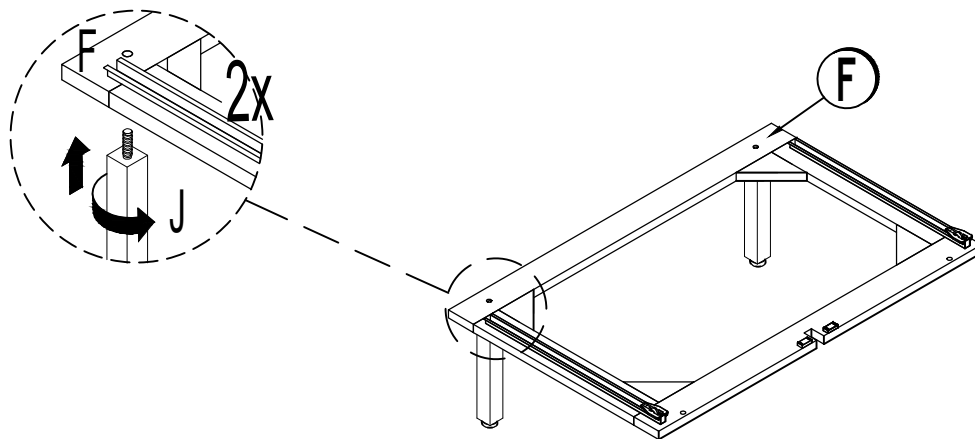

ITEM NO.
B1424-110 TALCOTT - KING HEADBOARD
B1424-128 TALCOTT - KING FOOTBOARD / S. FRAME / SLATS & LEG
B1424-230 TALCOTT - C.KING SIDE RAILS
B1424-128D TALCOTT - KING STORAGE DRAWER

## STEP 2 :

Assemble the drawer track frame to the Footboard (B) using Allen Key M4 (7) with hardware 4, 5, and 6.

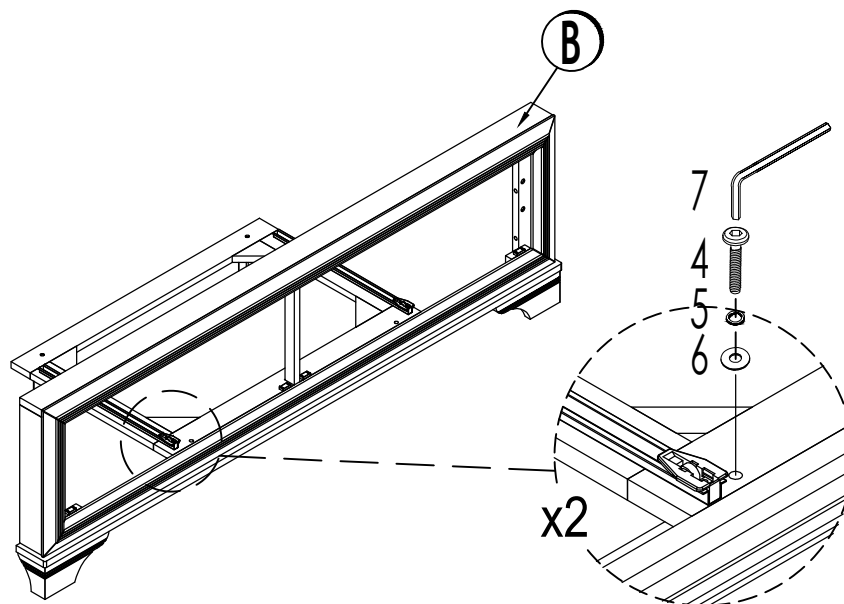

## STEP 3 :

Assemble the Side Rail (C) To the Headboard (A) and Footboard (B) by using Allen key M5 (3) with hardware 1 and 2.

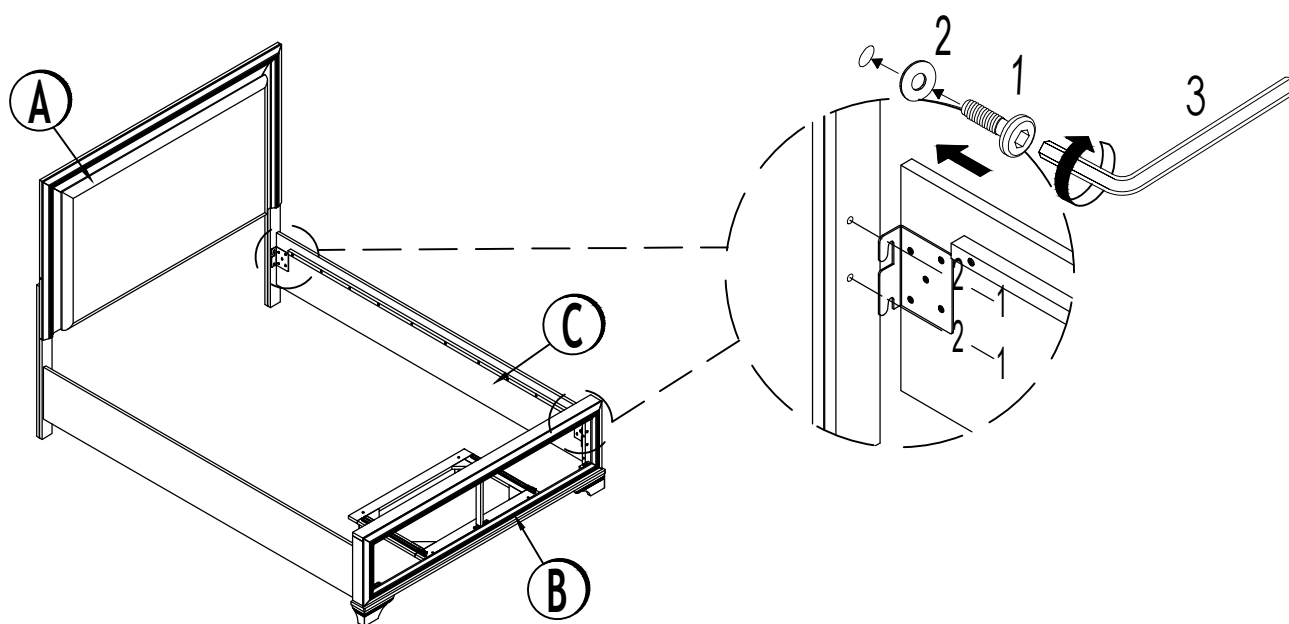

# Assembly Instructions

ITEM NO.  
 B1424-110 TALCOTT - KING HEADBOARD  
 B1424-128 TALCOTT - KING FOOTBOARD / S. FRAME / SLATS & LEG  
 B1424-230 TALCOTT - C.KING SIDE RAILS  
 B1424-128D TALCOTT - KING STORAGE DRAWER

## STEP 4 :

Lay out the Roll-out Slat (D) on a flat surface and place the Center Slat (E) in the center.  
 Assemble the Long Slat Support Leg (H) through the Center Slat (E) to the Roll-out Slat (D).

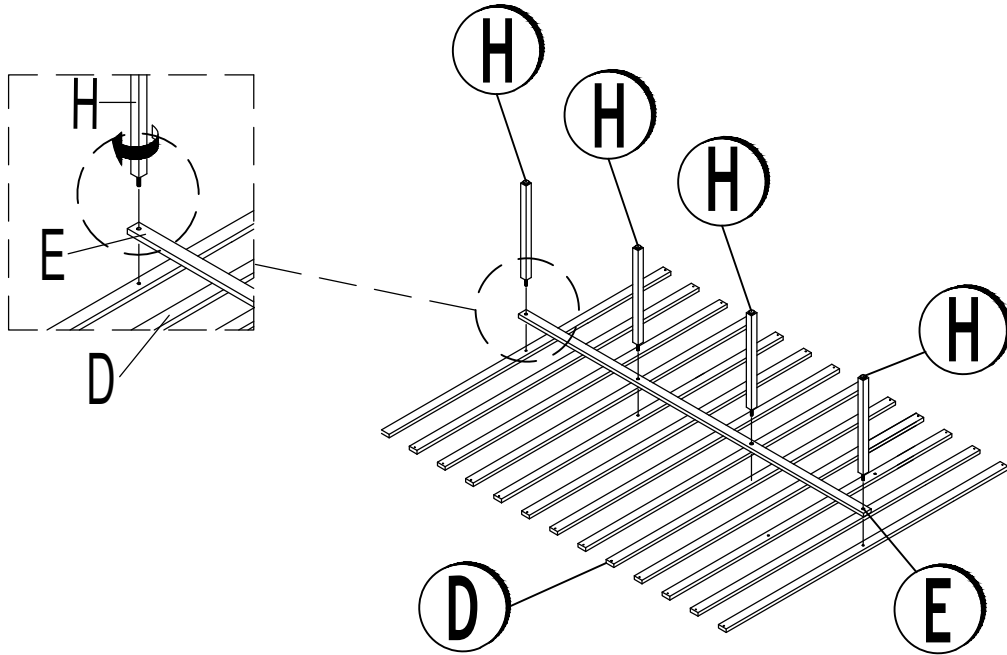

## STEP 5 :

Locate the 3rd slat of the Roll-out Slat (D) that has two extra slat support holes.  
 Assemble the Short Slat Support Leg (I) to 3rd slat of the Roll-out Slat (D)

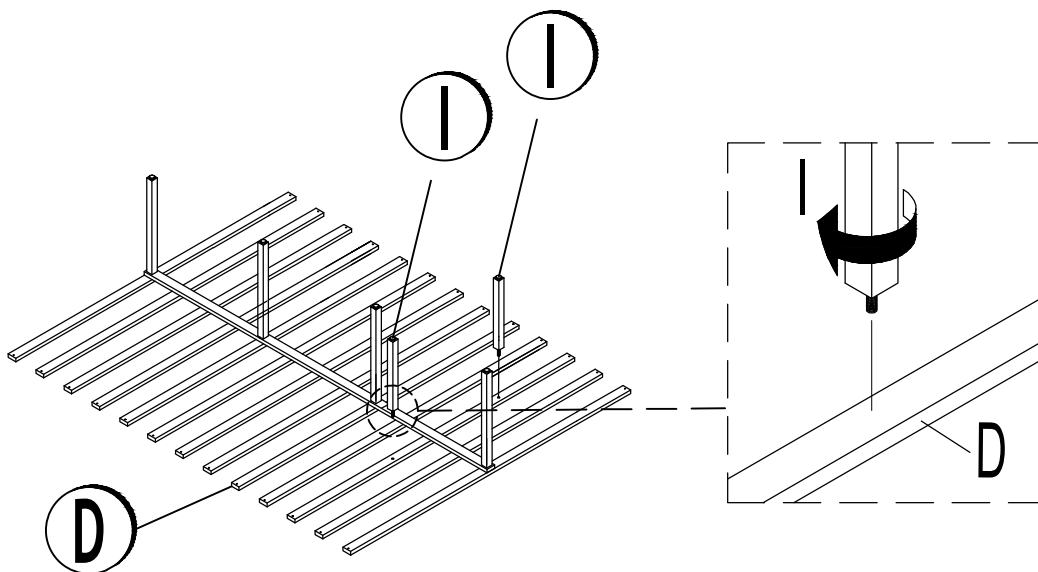

# Assembly Instructions

ITEM NO.  
 B1424-110 TALCOTT - KING HEADBOARD  
 B1424-128 TALCOTT - KING FOOTBOARD / S. FRAME / SLATS & LEG  
 B1424-230 TALCOTT - C.KING SIDE RAILS  
 B1424-128D TALCOTT - KING STORAGE DRAWER

**STEP 6 :**

Place the Roll-out Slat (D) in the position indicated by the stoppers on the Side Rail (C). Make sure the first slat near the headboard and the last slat near the footboard are properly aligned to allow correct installation of the Short Slat Support Legs (I).

\*Check and ensure the Short Slat Support Legs (I) are standing on top of the drawer track (F).

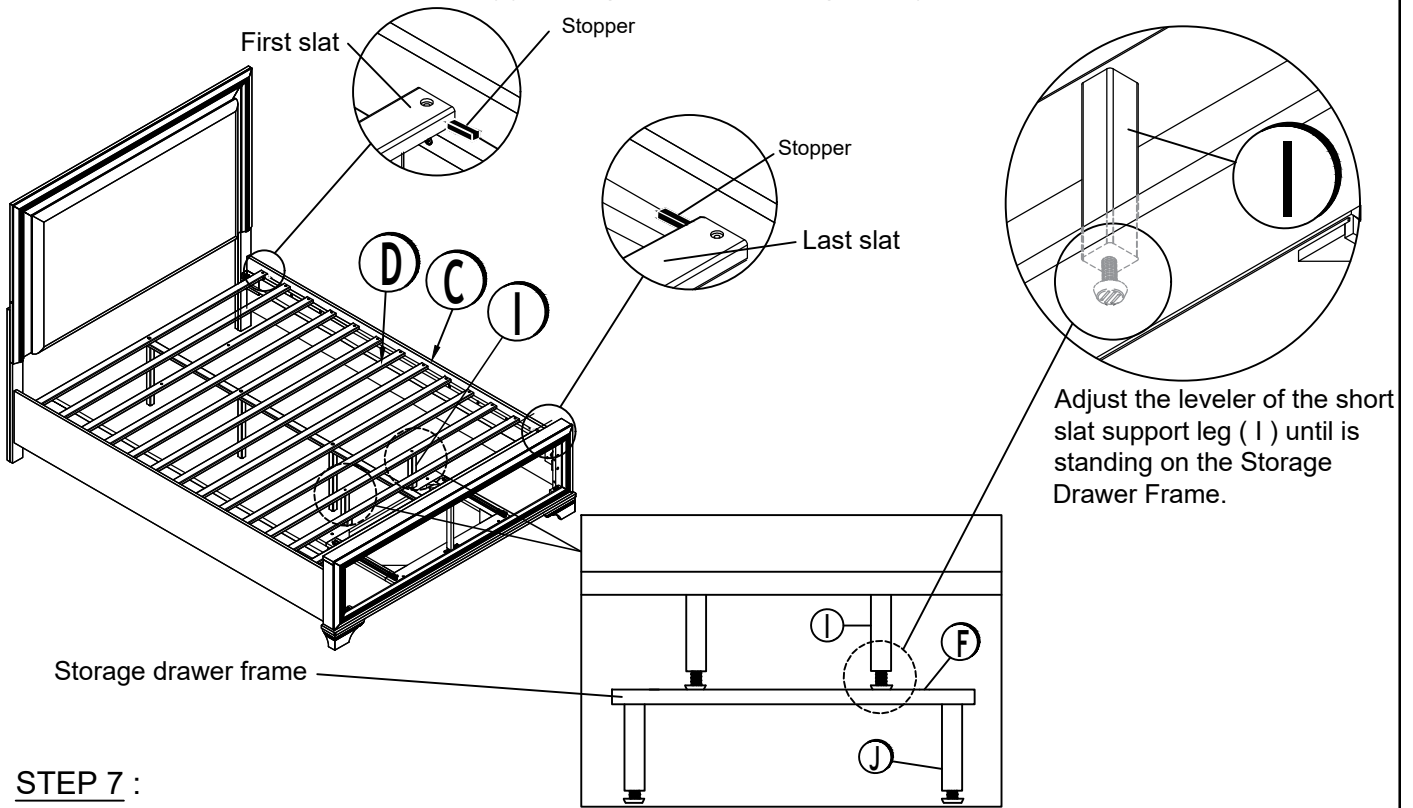

**STEP 7 :**

Assemble the Roll-out Slat (D) to the Side Rail (C) by using a screwdriver with hardware 8.

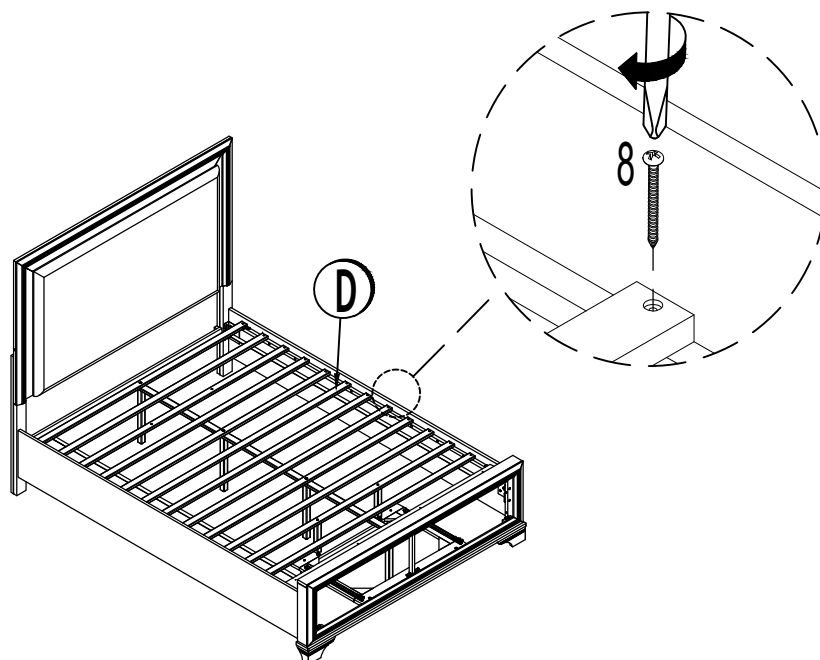

# Assembly Instructions

ITEM NO.

B1424-110 TALCOTT - KING HEADBOARD

B1424-128 TALCOTT - KING FOOTBOARD / S. FRAME / SLATS & LEG

B1424-230 TALCOTT - C.KING SIDE RAILS

B1424-128D TALCOTT - KING STORAGE DRAWER

**STEP 8 :**

Remove the handle from the inside of the Drawer (G) to the front of the Drawer (G) by using a screwdriver.

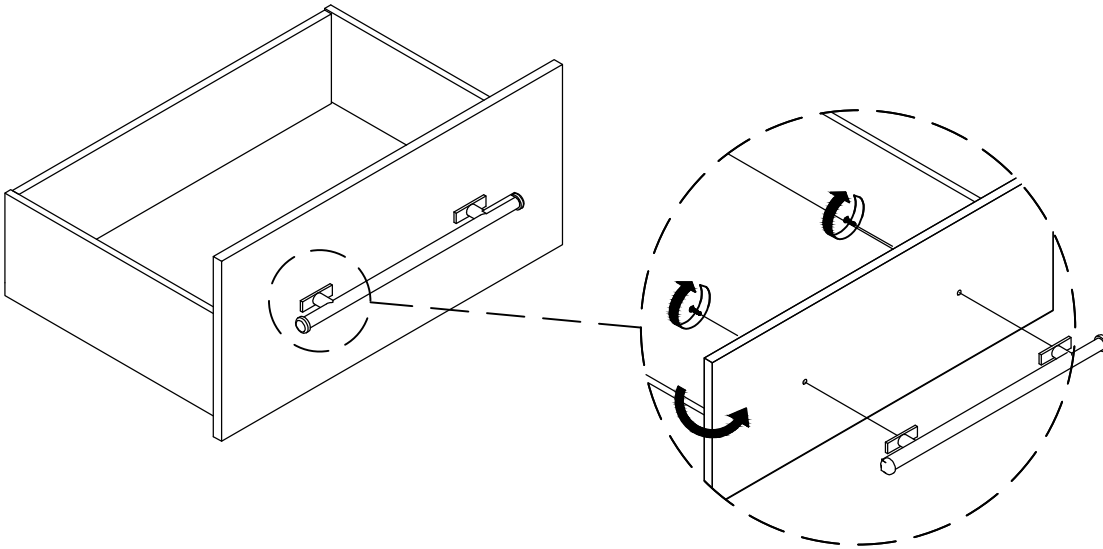

**STEP 9 :** Assembly the Side Rail Cap (K) to Side Rail (C) by using Allen Key M5 (3) with hardware 10, 5 and 11.

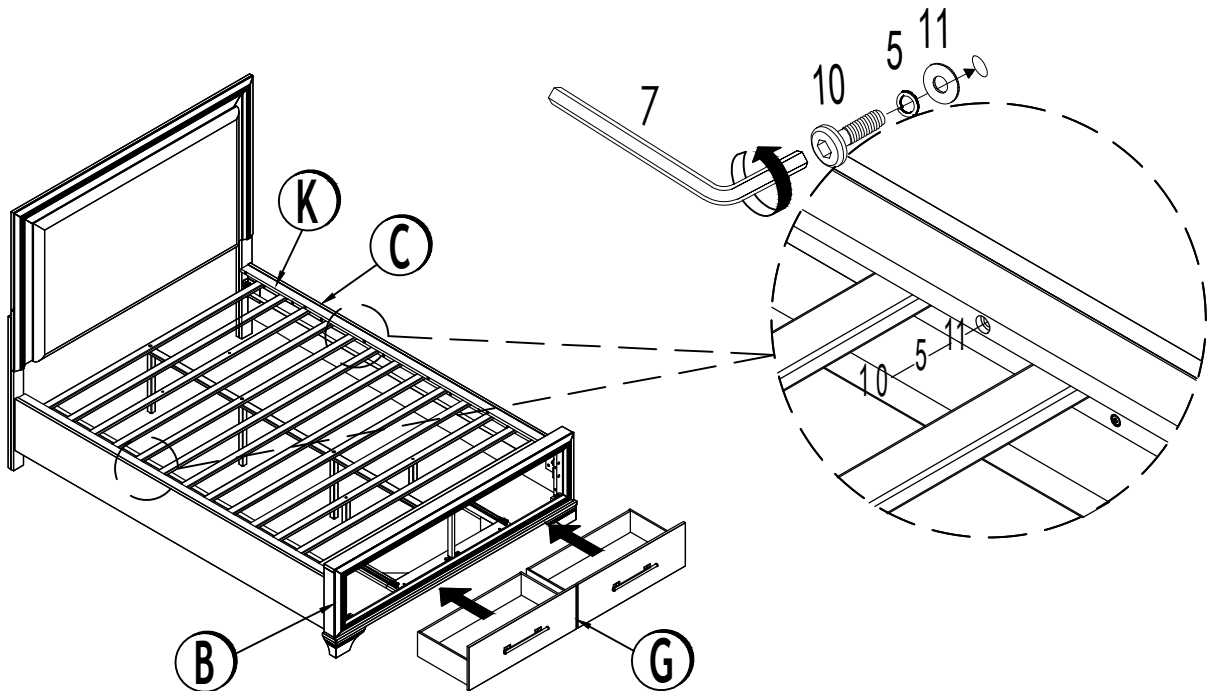

# Assembly Instructions

ITEM NO.

B1424-110 TALCOTT - KING HEADBOARD

B1424-128 TALCOTT - KING FOOTBOARD / S. FRAME / SLATS & LEG

B1424-230 TALCOTT - C.KING SIDE RAILS

B1424-128D TALCOTT - KING STORAGE DRAWER

## STEP 10 :

Attached Decking Board (K) to the Roll-out Slat (D) by using a screwdriver with hardware 10.

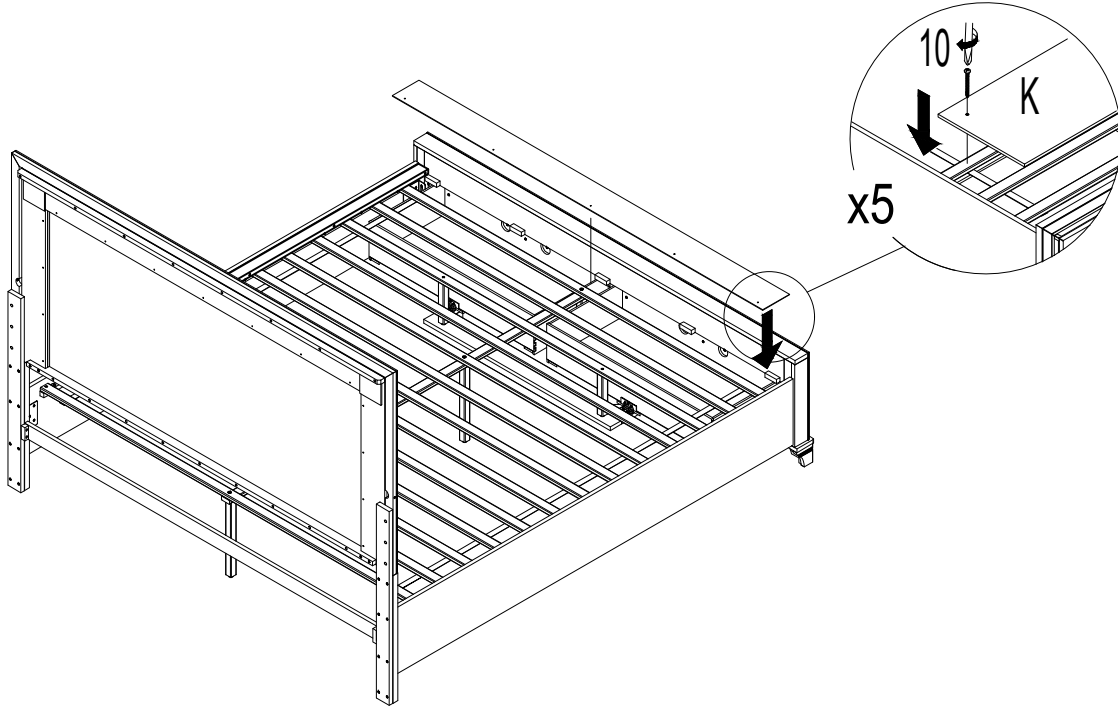

## STEP 11 :

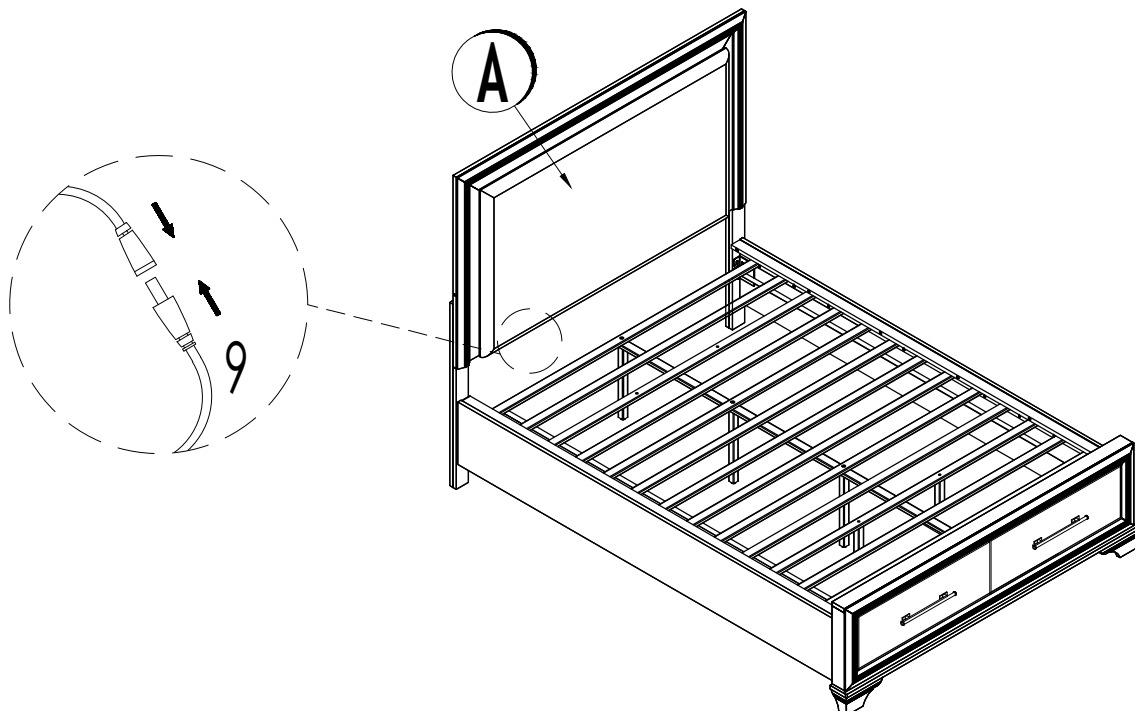

Connect the AC/DC Adaptor (9) with the wire on the headboard (A).







Thank you for purchasing this quality product. Be sure to check all packing materials carefully for small parts, which may have come loose inside the carton during shipment. Identify and count all items and compare with the parts list and/or hardware list shown below.

Caution : please read the instruction thoroughly before assembly.

1. We recommended that you assemble this product with the assistance of another person, this will make the assembly easier, and will help eliminate damage to the product or injury to persons during assembly.
2. Please do not tighten screws or bolt until the assembly is completed.
3. Please put all parts on a non-abrasive floor before assembly and follow the assembly steps to assemble your newly purchased product correctly and efficiently.

PARTS LIST			
NO.	DESCRIPTION	SKETCH	QTY
A	DRESSER		1 pc
B	LEG		4 pcs
C	LEG SUPPORT		1 pc

HARDWARE LIST			
NO.	DESCRIPTION	SKETCH	QTY
1	JCBC - M6 x 1-3/8"		8 pcs
2	SPRING WASHER - M8		8 pcs
3	FLAT WASHER - M8 x 25/32"		8 pcs
4	ALLEN KEY - M4		1 pc
5	ANTI TIPPING KIT		1 pc

**STEP 1 :** Locate the Leg (B) and Leg Support (C) pack in the lowest drawer.

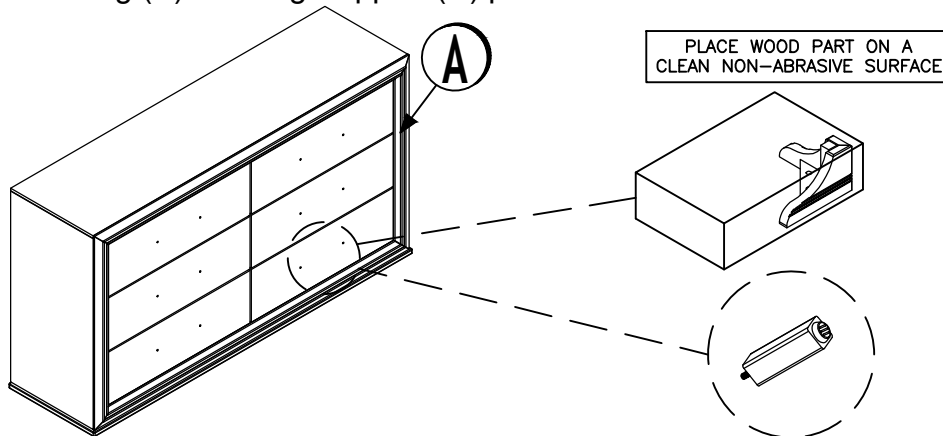

**STEP 2 :**

Assemble the Leg (B) to the Dresser (A) by using Allen Key (4) with hardware 1, 2, and 3

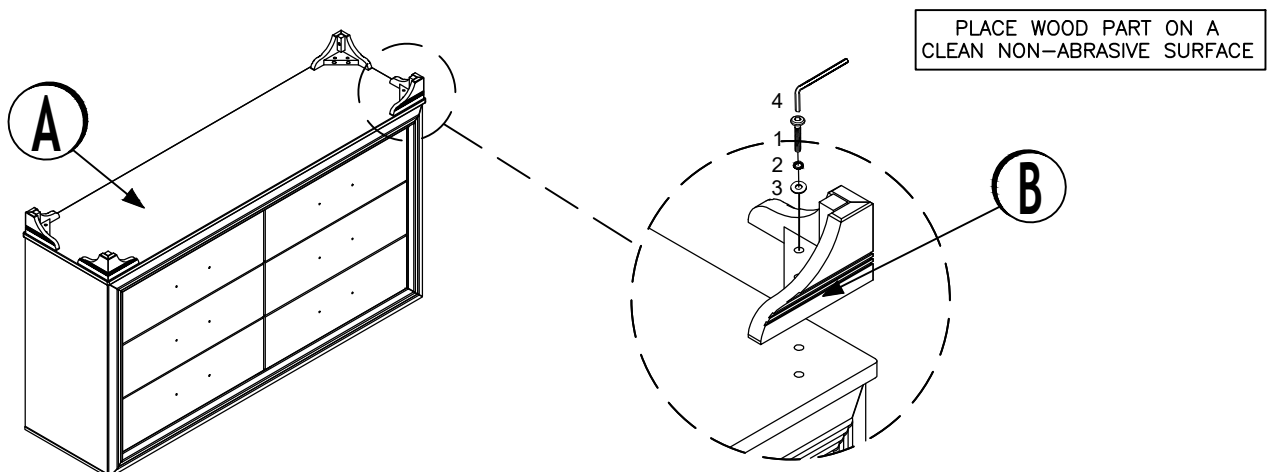

**STEP 3 :** Assembly the Leg Support (C) to the Dresser (A).

\*Twist to adjust the height of the leveler on Leg Support (C) for stability.

PLACE WOOD PART ON A CLEAN NON-ABRASIVE SURFACE

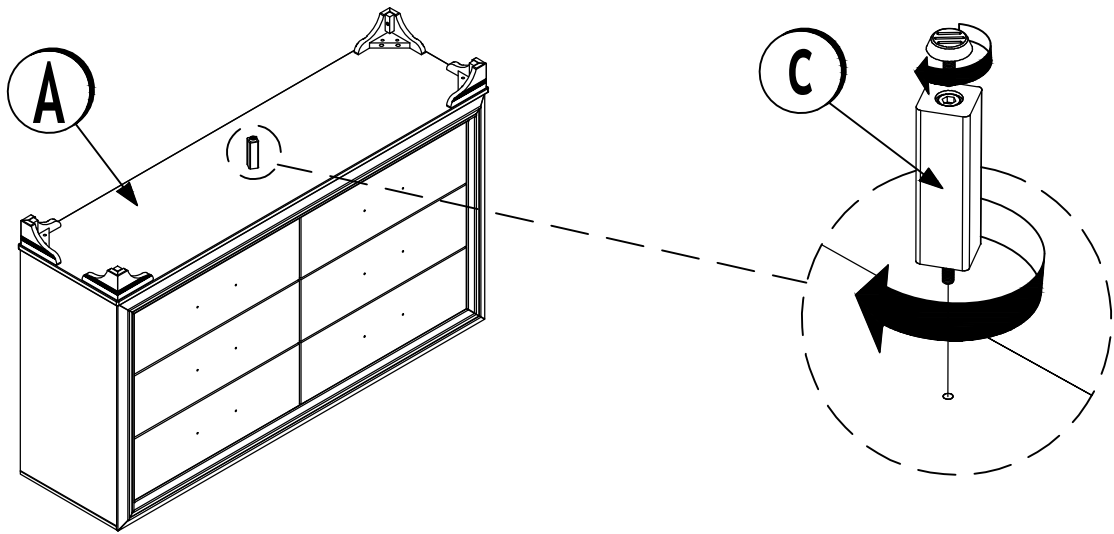

**STEP 4 :** Pull open the drawer and remove the handle from the inside of the drawer to the front of the drawer by using a screwdriver.

PLACE WOOD PART ON A CLEAN NON-ABRASIVE SURFACE

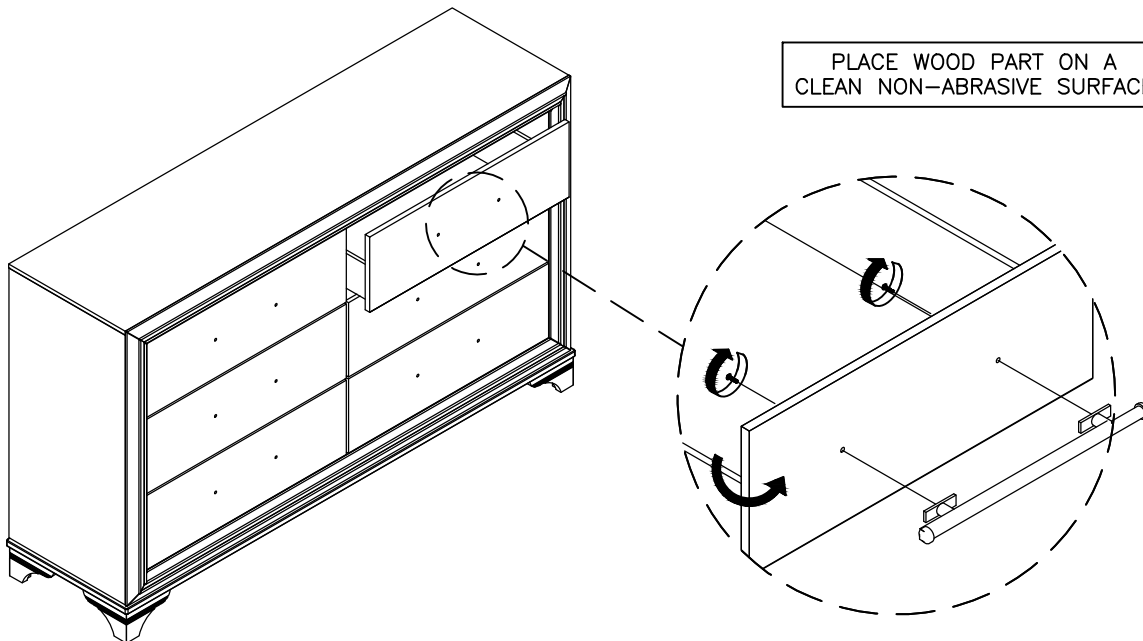

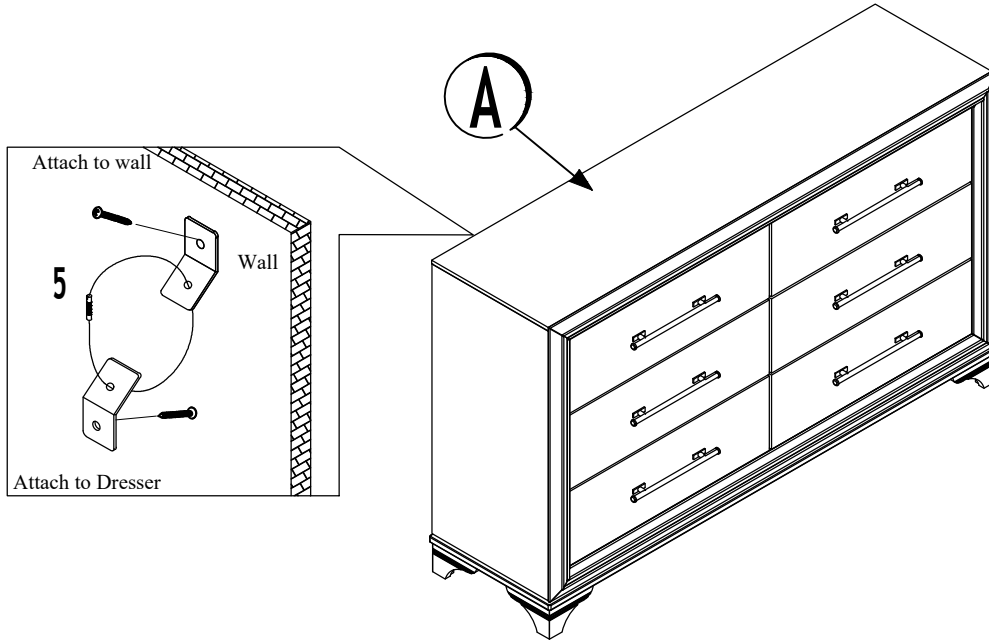

**STEP 5** : Assembly the Anti-Tipping Kit (5) to the Dresser (A).







Thank you for purchasing this quality product. Be sure to check all packing materials carefully for small parts, which may have come loose inside the carton during shipment. Identify and count all items and compare with the parts list and/or hardware list shown below.

Caution : please read the instruction thoroughly before assembly.

1. We recommended that you assemble this product with the assistance of another person, this will make the assembly easier, and will help eliminate damage to the product or injury to persons during assembly.
2. Please do not tighten screws or bolt until the assembly is completed.
3. Please put all parts on a non-abrasive floor before assembly and follow the assembly steps to assemble your newly purchased product correctly and efficiently.

PARTS LIST			
NO.	DESCRIPTION	SKETCH	QTY
A	MIRROR		1 pc
B	MIRROR SUPPORT		2 pcs
C	DRESSER		1 pc

HARDWARE LIST			
NO.	DESCRIPTION	SKETCH	QTY
1	JCBC - M6 x 1-3/8"		8 pcs
2	SPRING WASHER - M8		8 pcs
3	FLAT WASHER - M8 x 25/32"		8 pcs
4	ALLEN KEY - M4		1 pc

**STEP 1 :** Assemble the Dresser (C) with the Mirror Support (B) by using Allen Key (4) with hardware 1, 2 AND 3.

PLACE WOOD PART ON A  
CLEAN NON-ABRASIVE SURFACE

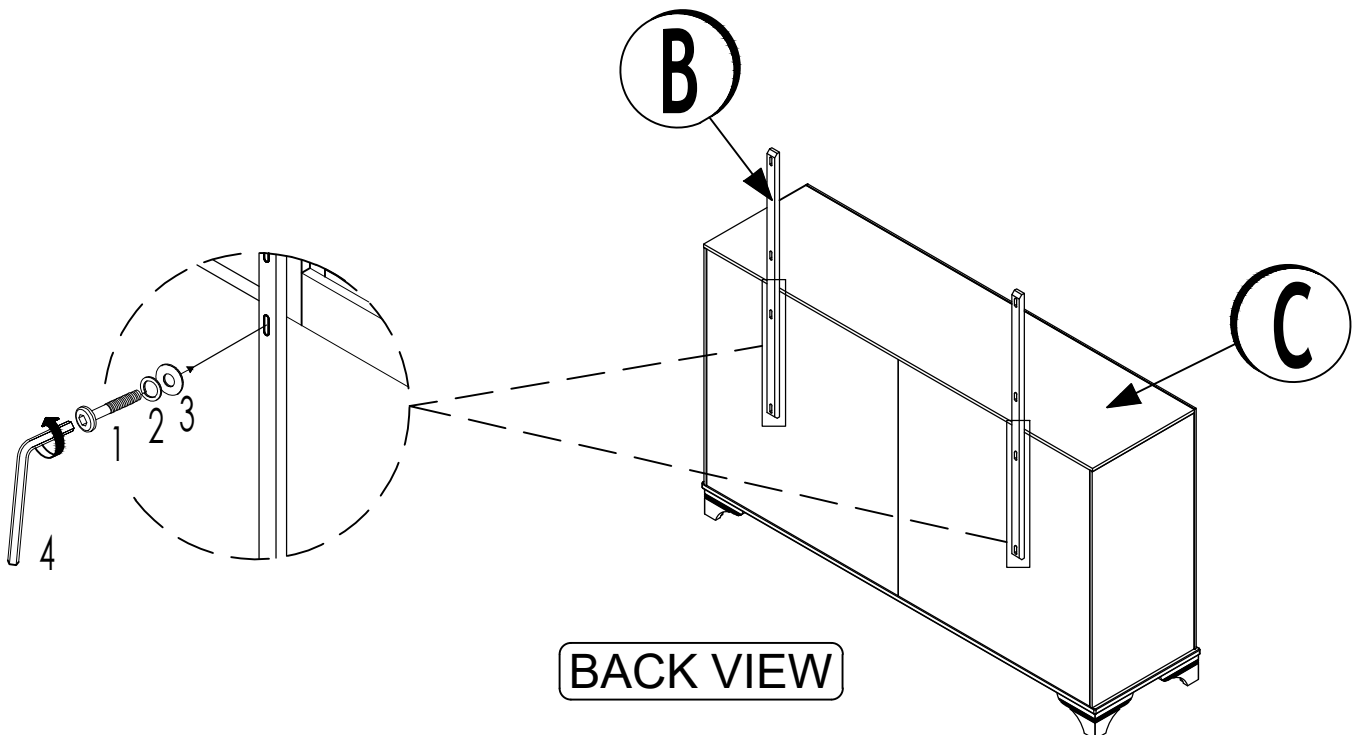

Thank you for purchasing this quality product. Be sure to check all packing materials carefully for small parts, which may have come loose inside the carton during shipment. Identify and count all items and compare with the parts list and/or hardware list shown below.

**STEP 2** : Assemble the Mirror Support (B) with the Mirror (A) by using Allen Key (4) with hardware 1, 2 and 3.

PLACE WOOD PART ON A  
CLEAN NON-ABRASIVE SURFACE

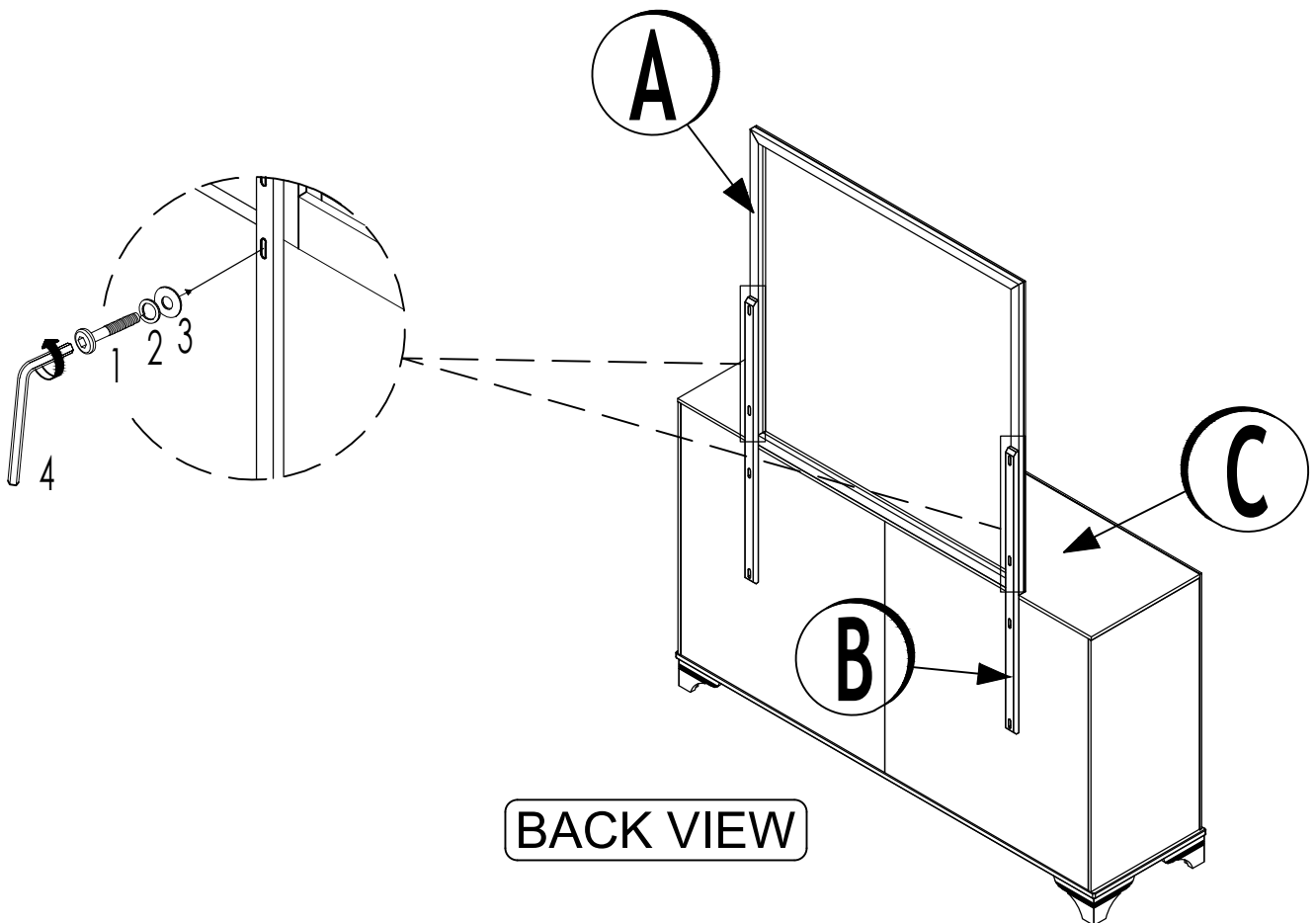

BACK VIEW



# Assembly Instructions





**ITEM NO. B1424-070  
TALCOTT - CHEST**

Thank you for purchasing this quality product. Be sure to check all packing materials carefully for small parts, which may have come loose inside the carton during shipment. Identify and count all items and compare with the parts list and/or hardware list shown below.

Caution : please read the instruction thoroughly before assembly.

1. We recommended that you assemble this product with the assistance of another person, this will make the assembly easier, and will help eliminate damage to the product or injury to persons during assembly.
2. Please do not tighten screws or bolt until the assembly is completed.
3. Please put all parts on a non-abrasive floor before assembly and follow the assembly steps to assemble your newly purchased product correctly and efficiently.

PARTS LIST			
NO.	DESCRIPTION	SKETCH	QTY
A	CHEST		1 pc
B	LEG		4 pcs

HARDWARE LIST			
NO.	DESCRIPTION	SKETCH	QTY
1	JCBC - M6 x 1-3/8"		8 pcs
2	SPRING WASHER - M8		8 pcs
3	FLAT WASHER - M8 x 25/32"		8 pcs
4	ALLEN KEY - M4		1 pc
5	ANTI TIPPING KIT		1 pc

**STEP 1 :** Locate the Leg (B) pack in the lowest drawer.

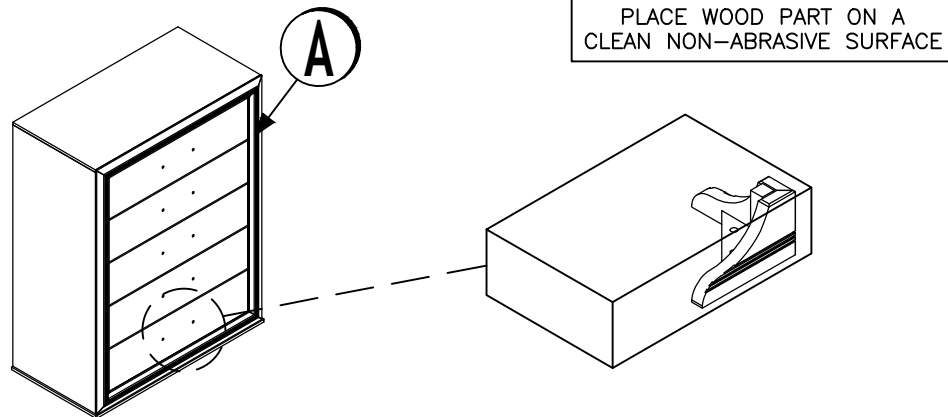

**STEP 2 :**

Assemble the Leg (B) to the Chest (A) by using Allen Key (4) with hardware 1, 2, and 3.

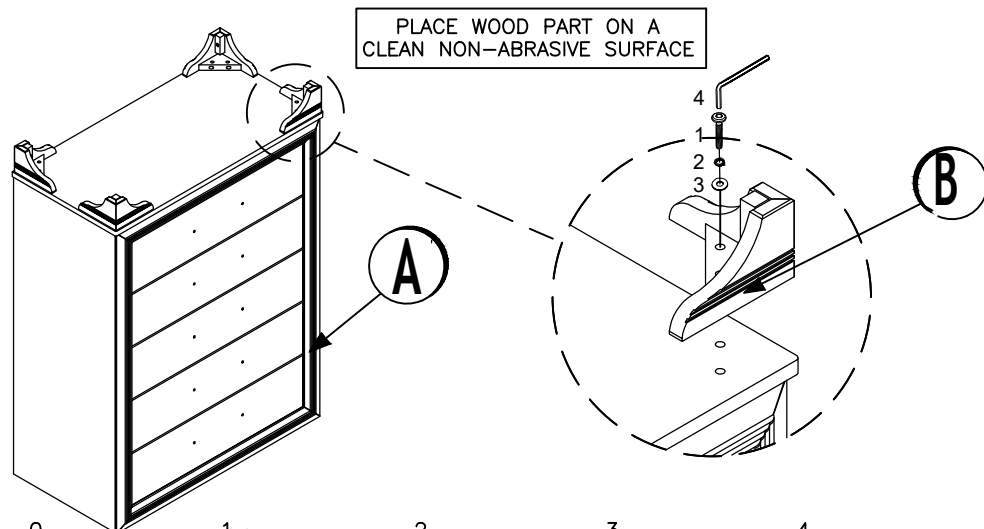

**STEP 3 :** Pull open the drawer and remove the handle from the inside of the drawer to the front of the drawer by using a screwdriver.

PLACE WOOD PART ON A CLEAN NON-ABRASIVE SURFACE

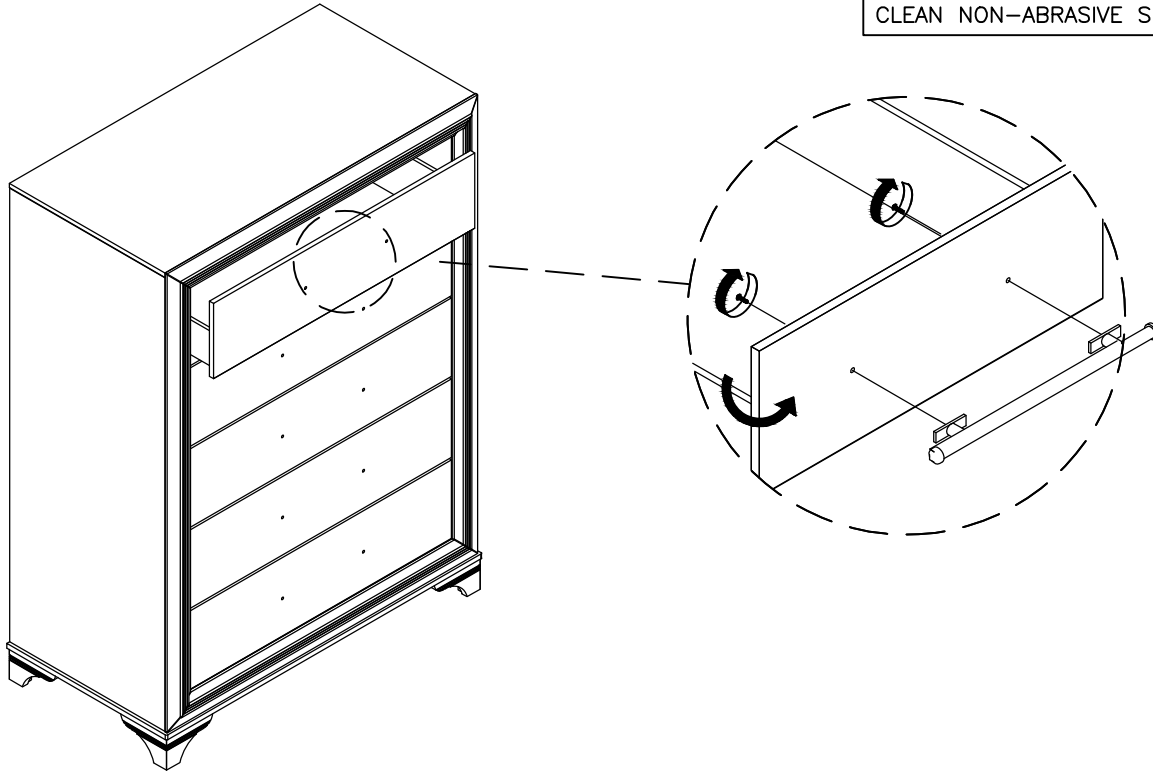

**STEP 4 :** Assembly the Anti-Tipping Kit (5) to the Chest (A).

