



# Assembly Instructions

ITEM NO. D4212-13  
 "CITYSCAPE 52" ROUND GLASS TOP DINING TABLE  
 (1 PC/CTN)

Thank you for purchasing this quality product. Be sure to check all packing materials carefully for small parts, which may have come loose inside the carton during shipment. Identify and count all items and compare with the PARTS LIST and/or HARDWARE LIST shown below.



Please read the instructions thoroughly before assembly.

1. We recommend that you assemble this product with the assistance of another person; this will make the assembly easier, and will help eliminate damage to the product or injury to persons during assembly.
2. Please do not tighten screws or bolts until the assembly is completed.
3. To level the chairs or table, before tightening all the screws, the chairs or table must be placed on a flat surface and then tighten the screws.
4. Please put all parts on a non-abrasive floor before assembly and follow the assembly steps to assemble your newly purchased product correctly and efficiently.

### PARTS LIST

NO.	COMPONENT	SKETCH	QTY
A	TABLE TOP		1PC
B	LEGS		4PCS
C	PLATE		1PC
D	FEET		4PCS
E	GLASS		1PC

### HARDWARE LIST

NO.	COMPONENT	SKETCH	QTY
1	FLAT WASHER 5/16" DIA.		12 PCS
2	SPRING WASHER 5/16" DIA.		12 PCS
3	SHORT BOLT 5/16" x 2 5/32"		8 PCS
4	LONG BOLT 5/16" x 5 1/2"		4 PCS
5	ALLEN WRENCH ( 4mm )"		1 PC
6	BUMPER PLASTIC		4 PCS

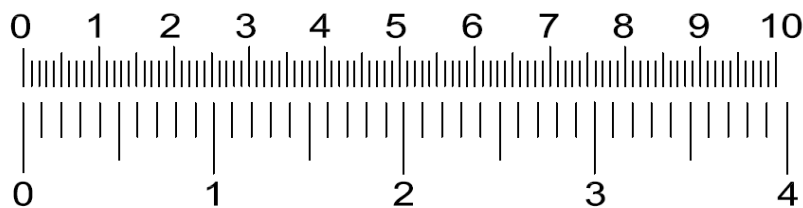

# Assembly Instructions

ITEM NO. D4212-13  
"CITYSCAPE 52" ROUND GLASS TOP DINING TABLE"  
(1 PC/CTN)

## STEP 1

Place the table top (A) upside down on a soft and clean surface . Assemble the legs (B) one by one with the table top (A) by using Allen Wrench (5) with hardware 1,2, and 3 .

Attention: DO NOT TIGHTEN THE BOLTS

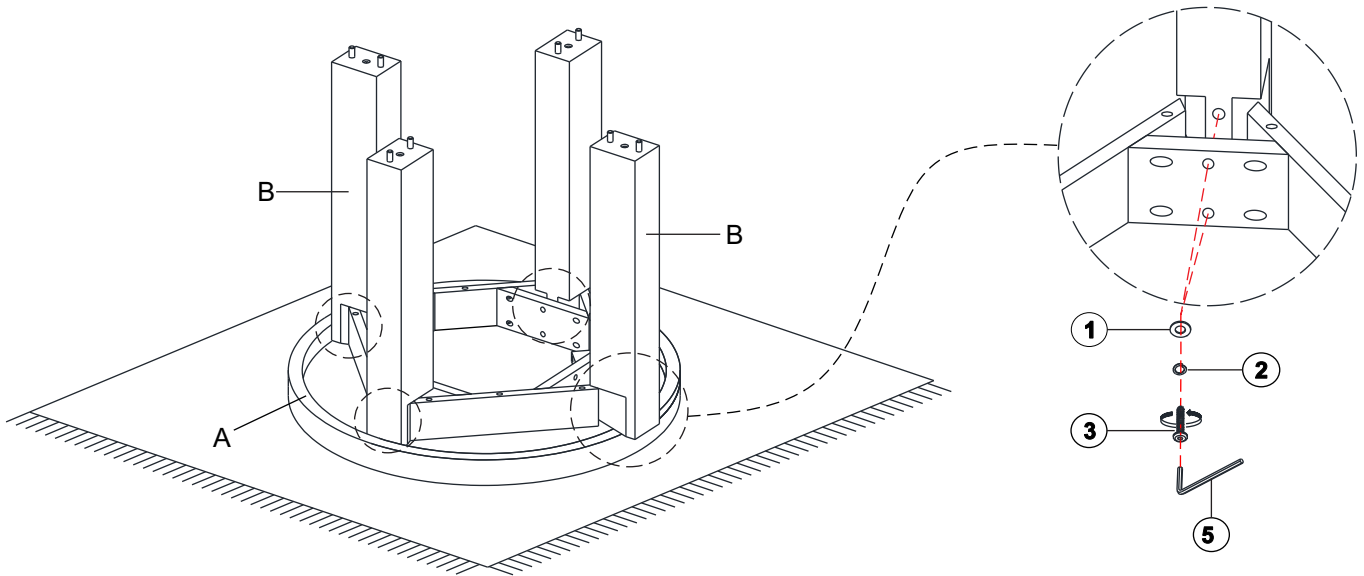

## STEP 2

Put the plate (C) on to the legs (B), align the holes in the plate with the wood dowels in the legs, then push the plate on to the legs.

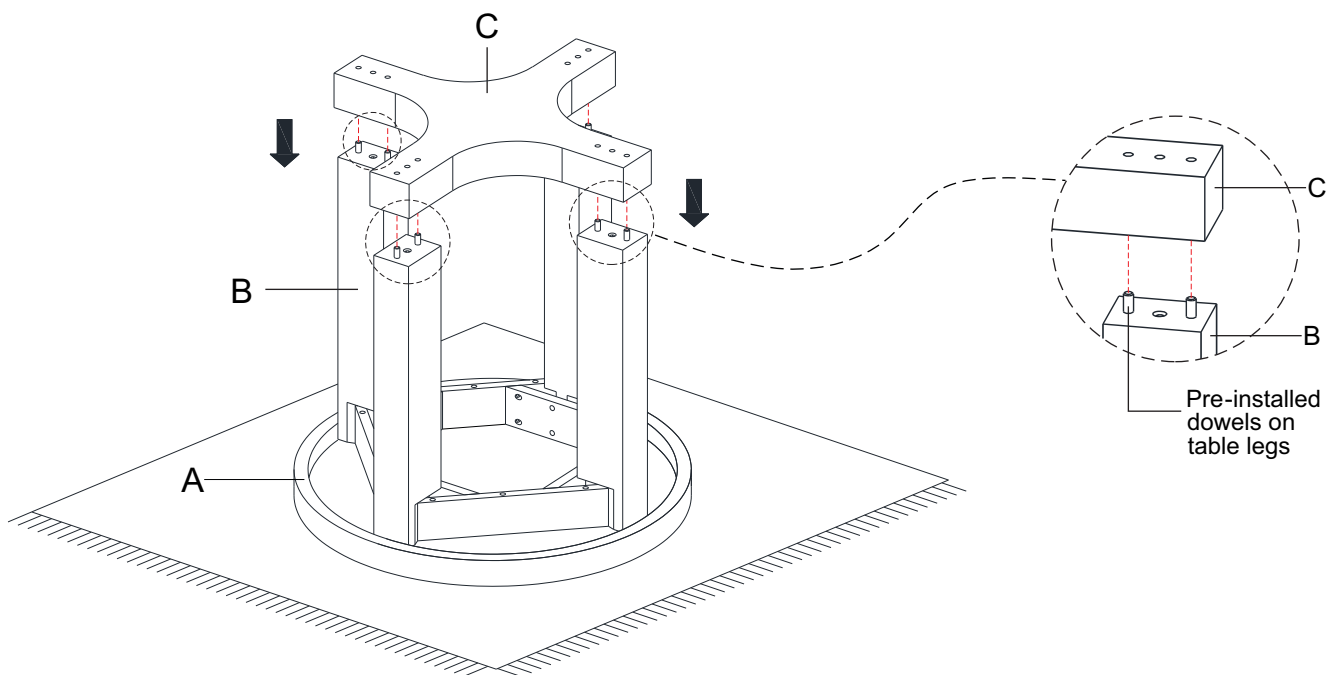

# Assembly Instructions

ITEM NO. D4212-13  
 "CITYSCAPE 52" ROUND GLASS TOP DINING TABLE  
 (1 PC/CTN)

## STEP 3

Put the feet (D) with the pre-installed dowel ends down to the plate (C). Align the wood dowels in the feet with the holes in the plate, then push the feet on to the plate. Assemble the feet together with the legs and plate by using Allen Wrench (5) with hardware 1, 2, and 4. Please tighten the bolts (4)

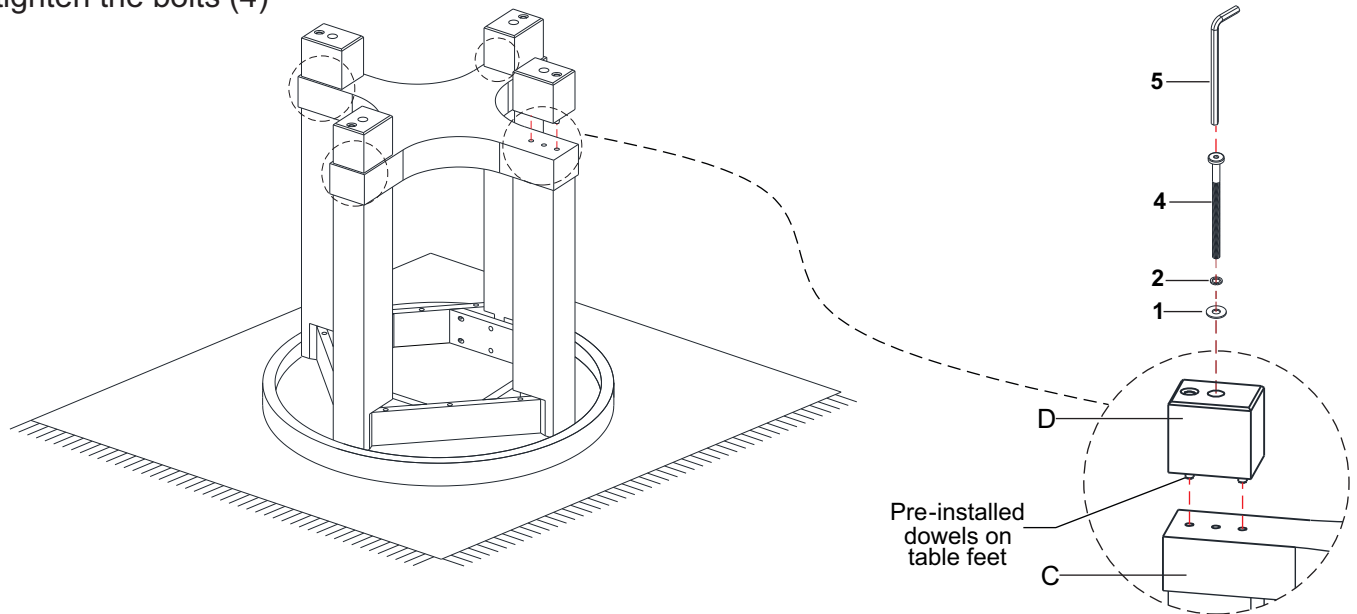

## STEP 4

Stand the table up right to install the pumper plastic (6) to the table top (A). Align and push the pumper plastic (6) all the way into holes on the table top (A).

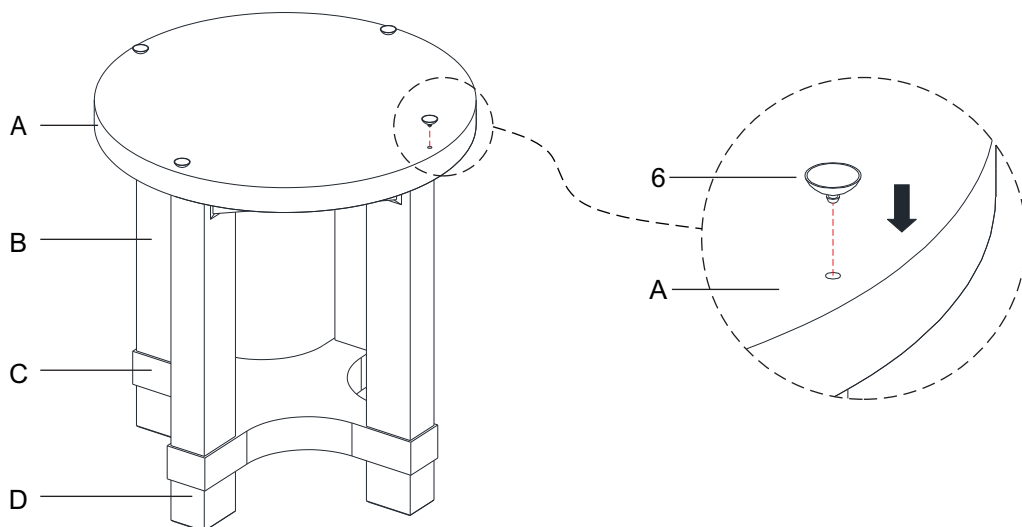

# Assembly Instructions

ITEM NO. D4212-13  
"CITYSCAPE 52" ROUND GLASS TOP DINING TABLE"  
(1 PC/CTN)

## STEP 5

To level the table, stand the table up on a plate surface and tighten all the bolts (3) and (4) by using Allen Wrench (5). Twist the adjustable glides till the server gets even.

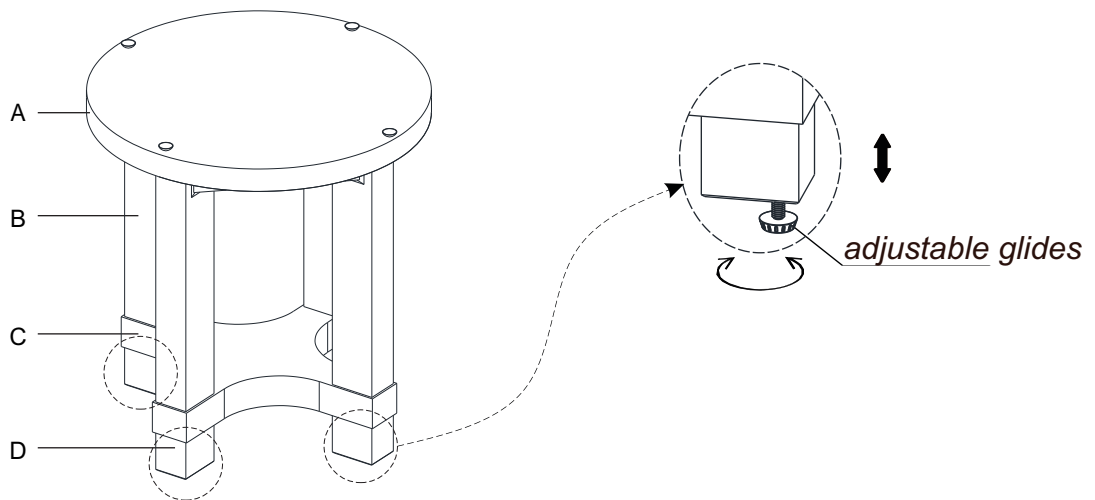

## STEP 6

Align and place the glass (E) on the table top (A).

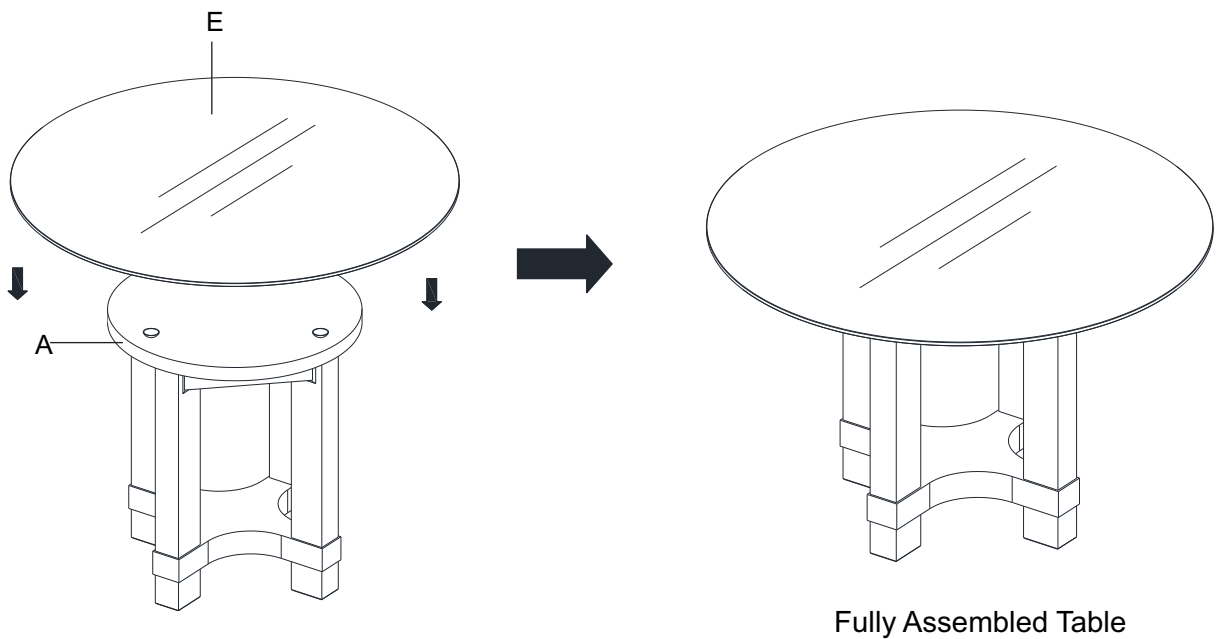



# Assembly Instructions

ITEM NO. D4212-20  
CITYSCAPE DINING CHAIR  
(2 PCS/CTN)

Thank you for purchasing this quality product. Be sure to check all packing materials carefully for small parts, which may have come loose inside the carton during shipment. Identify and count all items and compare with the PARTS LIST and/or HARDWARE LIST shown below.



Please read the instructions thoroughly before assembly.

1. We recommend that you assemble this product with the assistance of another person; this will make the assembly easier, and will help eliminate damage to the product or injury to persons during assembly.
2. Please do not tighten screws or bolts until the assembly is completed.
3. To level the chairs or table, before tightening all the screws, the chairs or table must be placed on a flat surface and then tighten the screws.
4. Please put all parts on a non-abrasive floor before assembly and follow the assembly steps to assemble your newly purchased product correctly and efficiently.

### PARTS LIST

NO.	COMPONENT	SKETCH	QTY
A	CHAIR BACK		2PCS
B	SEAT		2PCS
C1	RIGHT SIDE FACING (RSF) LEG		2PCS
C2	LEFT SIDE FACING (LSF) LEG		2PCS
D1	RIGHT SIDE FACING (RSF) STRETCHER		2PCS
D2	LEFT SIDE FACING (LSF) STRETCHER		2PCS

### HARDWARE LIST

NO.	COMPONENT	SKETCH	QTY
1	FLAT WASHER 1/4" DIA.		20 PCS
2	SPRING WASHER 1/4" DIA.		20 PCS
3	SHORT BOLT 1/4" x 1 1/2"		4 PCS
4	MEDIUM BOLT 1/4" x 2 5/32"		8 PCS
5	LONG BOLT 1/4" x 2 3/4"		8 PCS
6	ALLEN WRENCH ( 4mm )"		1 PC
7	WOOD SCREW 1/4" x 1 9/16"		8 PCS

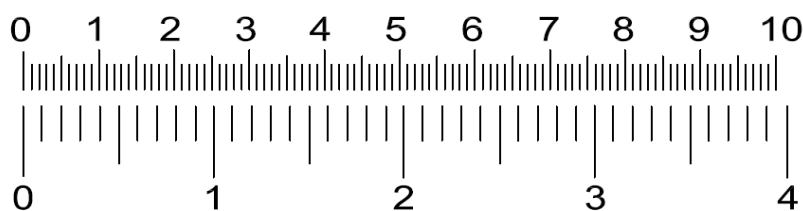

ITEM NO. D4212-20

CITYSCAPE DINING CHAIR

(2 PCS/CTN)

**STEP 1**

Place the chair back (A) on a soft and clean surface.  
Assemble the seat (B) with the chair back (A) by using Allen Wrench (6) with hardware 1,2, and 3. Then assemble the seat (B) with the back legs of the chair back (A) using Allen Wrench (6) with hardware 1,2, and 5  
\*Attention: DO NOT TIGHTEN THE BOLTS.

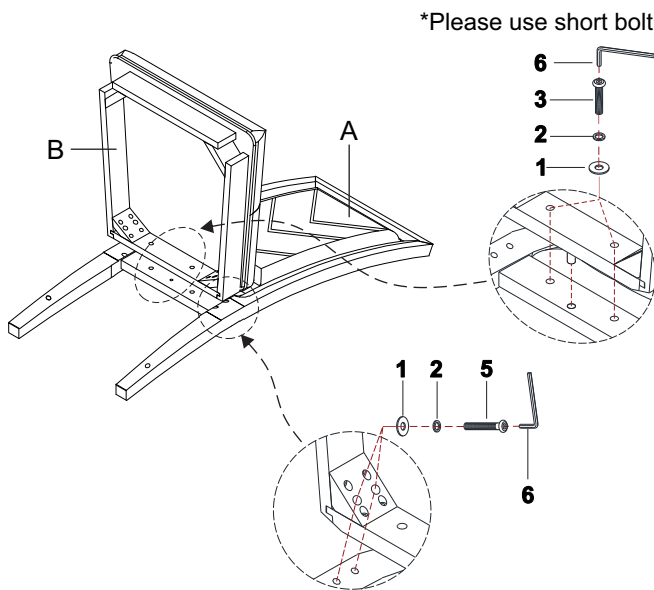

**STEP 2**

Assemble the front legs (C1) and (C2) with the seat (B) by using Allen Wrench (6) with hardware 1,2, and 4.  
\*Attention: DO NOT TIGHTEN THE BOLTS

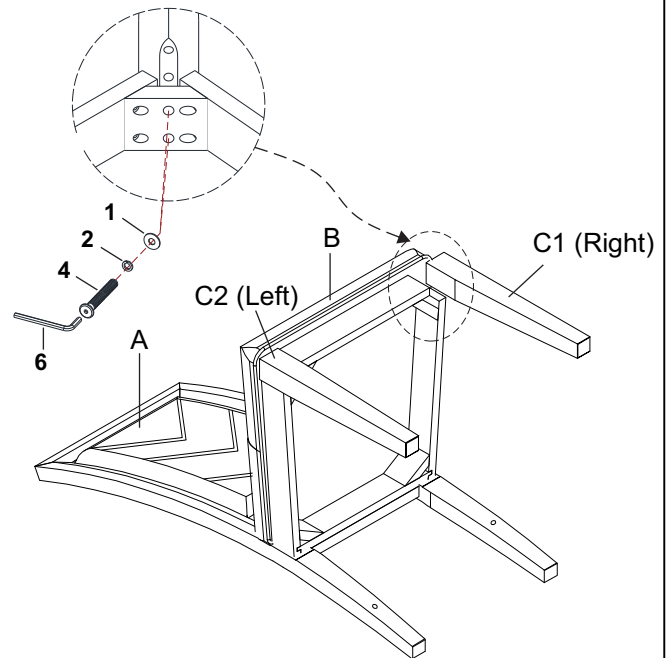

**STEP 3**

Install both RSF Stretcher (D1) and LSF Stretcher (D2) to chair back (A) and front legs (C1) and (C2) by using a screw driver with hardware 7.  
\*Attention: DO NOT TIGHTEN THE SCREWS

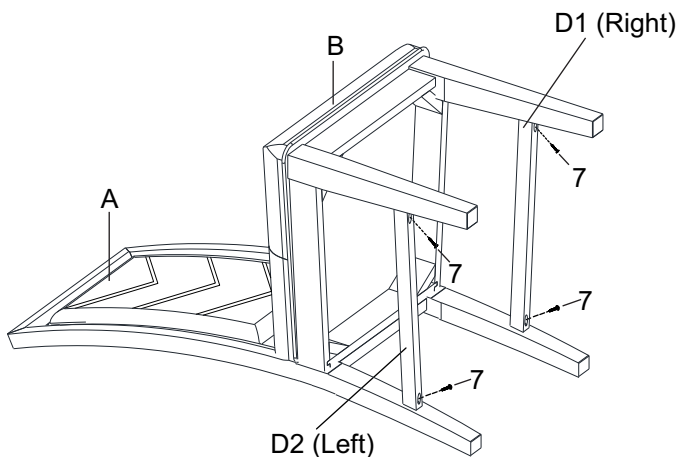

**STEP 4**

To level the chair, stand the chair up on a flat surface and tighten all the bolts by using Allen Wrench (6) and tighten all the screws by using a screw driver.

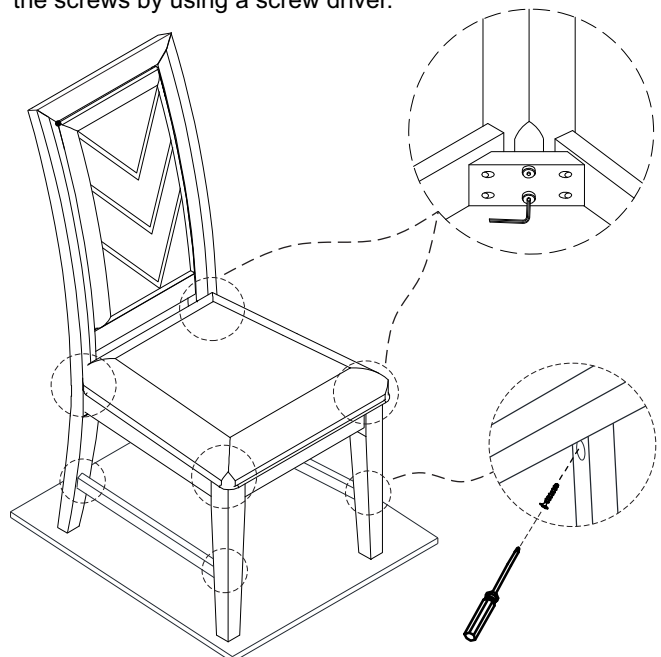



# Assembly Instructions

ITEM NO. D4212-20  
CITYSCAPE DINING CHAIR  
(2 PCS/CTN)

## STEP 5

Repeat STEP 1 through STEP 4 to assemble the other chair.

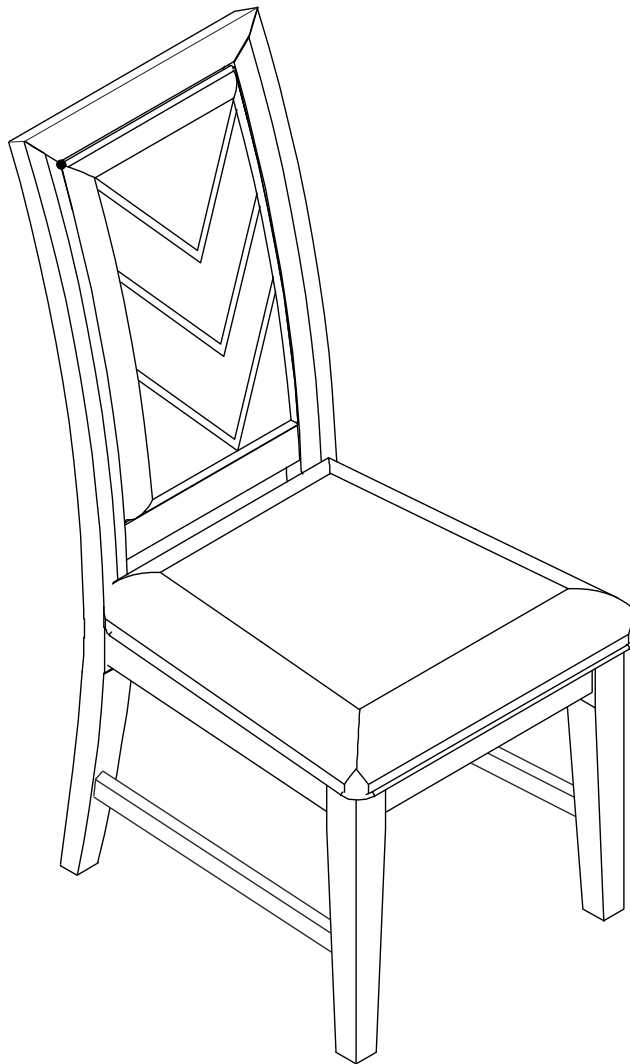

Fully Assembled Chair