

The design of this easy cutting machine is easy to disassemble and clean. The specific steps are as follows.

1. Pull up the clip, hold the position of the thickness regulator at the end of the knife plate with your hand, pull out slowly and forcefully, and then remove the parts of the knife plate. Please be careful with the blade when disassembling.

2. Rotate the push rod counterclockwise to pull it out of the push plate.

Note: In order to prevent the cutter from turning too hard, please clean the channel of cutter shaft regularly.

The grinding of a cutting tool

Sharpen your knife to increase its sharpness according to the following instructions:

1. If the parts can be adjusted, that is, adjust to the maximum cutting width.

2. Remove the cutter plate components from the machine stand.

3. Grind the flat side of the blade with a grindstone (do not file). If you need to grind the beveled side, be sure to maintain the original Angle.

Remove the blade

Remove the disc part from the stand for cleaning, then use a screwdriver to unscrew the blade and remove the blade.

Addition of lubricating oil

Add food grade mineral oil or oils with the same function (do not use edible oils)

Cutter shaft and shaft channel.

The lubricating oil added frequency varies according to the frequency of use of the machine and the way of cleaning. It can be added whenever the machine needs to be added.

Other supplementary

If any other parts need to be repaired, please contact us directly.

The contents of this manual and the specifications of this product are subject to change without prior notice.

Simple fruit and vegetable cutting

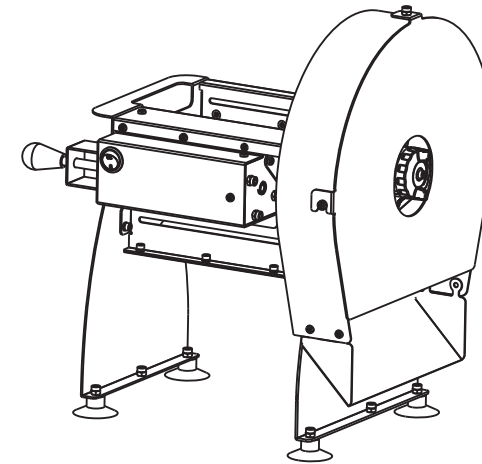

SD-3139AL

Simple fruit and vegetable cutting machine Operation and maintenance instructions

Important items

1. In order to better use the machine and extend its service life, please carefully read and operate according to the following instructions.
2. According to the following cleaning instructions, please clean the machine after use.
3. Avoid the use of alkaline washing products to avoid the machine being corroded and blunt. Do not use the dishwasher to clean the machine.
4. This machine is only suitable for cutting fruits and vegetables. Do not use it for cutting hard food (shell, core, nut, sugar cane, etc.). Do not use in cutting meat or other products, bone, tough skin or other hard food.
5. The electric mode of the machine can reduce labor force and improve efficiency, but it cannot replace industrial production equipment. The continuous working time does not exceed 30 minutes, which is conducive to extending the service life of the motor.

Safety instructions

1. The blade is extremely sharp. Please do not touch the blade with both hands when using and installing the blade.
2. Be sure to put the protective cover and knife plate in the correct position when using. Push the food towards the blade, not the hand. Do not put your hand into the trough when cutting.
3. In case the blade is stuck during use, do not operate the machine by force. Remove the knife plate to remove the stuck objects, and check whether the blade is defective at the same time to prevent the defective fragments from falling into the processed food.
4. Pay attention to protective measures and do not remove the protective cover for cutting. When putting food into the trough, be careful not to touch the blade.
5. Install the rubber strip on the protective cover or other sharp edges to prevent contact damage.
6. Do not use broken wires or plugs, or operate or damage in any way any appliance in the event of malfunction.
7. If the power cord of the machine is damaged or other mechanical failure, or is damaged by a fall or other ways, do not repair it without permission, but give it to the nearby seller or professional personnel appointed by the manufacturer for repair and service.

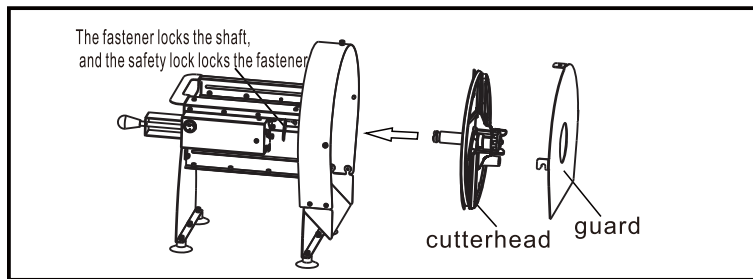

The installation

1. The machine stand is placed on the horizontal table. Smooth and clean surface is conducive to a firmer grip on the suction foot.
2. Install the rubber strip to the side Angle of the machine stand or other sharp edges.
3. Open the safety lock beside the clamp, and put the clamp on and pull, then put the knife disc shaft into the shaft hole channel of the machine base. Push the knife disc to the end, use the clamp to jam the knife disc shaft, and then lock the safety lock, so that the clamp cannot pull up and prevent the knife disc from falling out during work.
4. Put the guard plate on the cover of the machine seat, hang both sides of the guard plate on the cover, and lock the guard plate with nut.
5. Switch the power switch on the machine to the off position, plug the input end of the power box into the socket, and plug the output end of the power box into the power socket of the machine.

- ① shield
- ② regulator
- ③ guard
- ④ stand
- ⑤ The push rod handle
- ⑥ Clasp and safety lock
- ⑦ The connecting shaft
- ⑧ The power switch
- ⑨ power socket

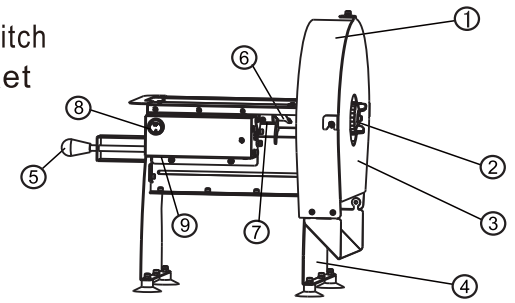

Operation

1. Make sure to adjust the section thickness, and adjust it if necessary.
2. Hold the push handle and put the food into the trough.
3. Gently release the push rod to press the push plate against the food, and then turn on the power switch. Turn off the power switch after the food in the trough has been cut.
3. the machine cutting thickness is easy to adjust, as long as through the blade on the regulator knob can adjust the cutting thickness.
4. The thickness of the slice is determined by the grain in the knife shaft.
5. If you need to use manual function to cut food, you need to take out the connecting shaft of the machine and install the handle on the knife plate. Then you can use manual function to cut food. Note: since the protection plate cannot be installed during manual cutting, it should be held at the end of the handle to keep hands away from the protection cover to prevent hand cuts from rubbing against the edge of the protection cover. Rubber strip protection can be installed at the edge of the protection cover.
6. Continuous working time shall not exceed 30 minutes during electric cutting. If the machine needs to work, the interval can be 10-15 minutes, wait for the machine to cool before using.

Operation skills

1. In order to make the slices even, the speed of the knife plate is slowed down with the increase of the thickness of the slices. This helps the food to be pushed fully into the plate before another blade starts cutting.
2. Before putting the food into the trough, the knife should be rotated at a certain Angle to hide the blade in the protective cover to prevent the hand from touching the blade when putting the food in.
3. When manually cutting food, after putting the food into the slot, turn the handle counterclockwise about 1/4 turn before turning the cutting direction. This ensures a quick start at the first cut of the slice. This will make the slicing easier and more uniform.
4. Do not put too much pressure on the putter, as this is unnecessary and will not improve the slicing or shredding effect
5. Please do not put too large food into the slot device of the machine, which will not only make it difficult to push the slices, but also hinder the uniformity of the slices.
6. Please keep the blade sharp.

cleaning

When cleaning, please try to avoid using alkaline washing products, alkaline washing products will pitting the machine, damage to the machine cleaning and replacement if necessary. Use clean water or add an appropriate amount of household dishwashing liquid.

This easy cutting machine is an assembly unit, which can be attached to the buckle. Remove the knife disk parts and put them into the sink for cleaning. Note that the knife disk parts should not be cleaned by dishwasher.