

ASSEMBLY INSTRUCTION

SKU CODE:N709P204629K / N709P204630K
N709P204629H / N709P204630H

INSTRUCTIONS DE MONTAGE

CODE UGS :N709P204629K / N709P204630K
N709P204629H / N709P204630H

TWIN SIZE DAYBED WITH 2 DRAWERS LIT DE JOUR DOUBLE AVEC 2 TIROIRS

This set included 2 boxex if do not receive full 2 boxex. Please contact our customer service team

Cet ensemble comprenait 2 boxex si vous ne recevez pas 2 boxex complets. Veuillez contacter notre service client

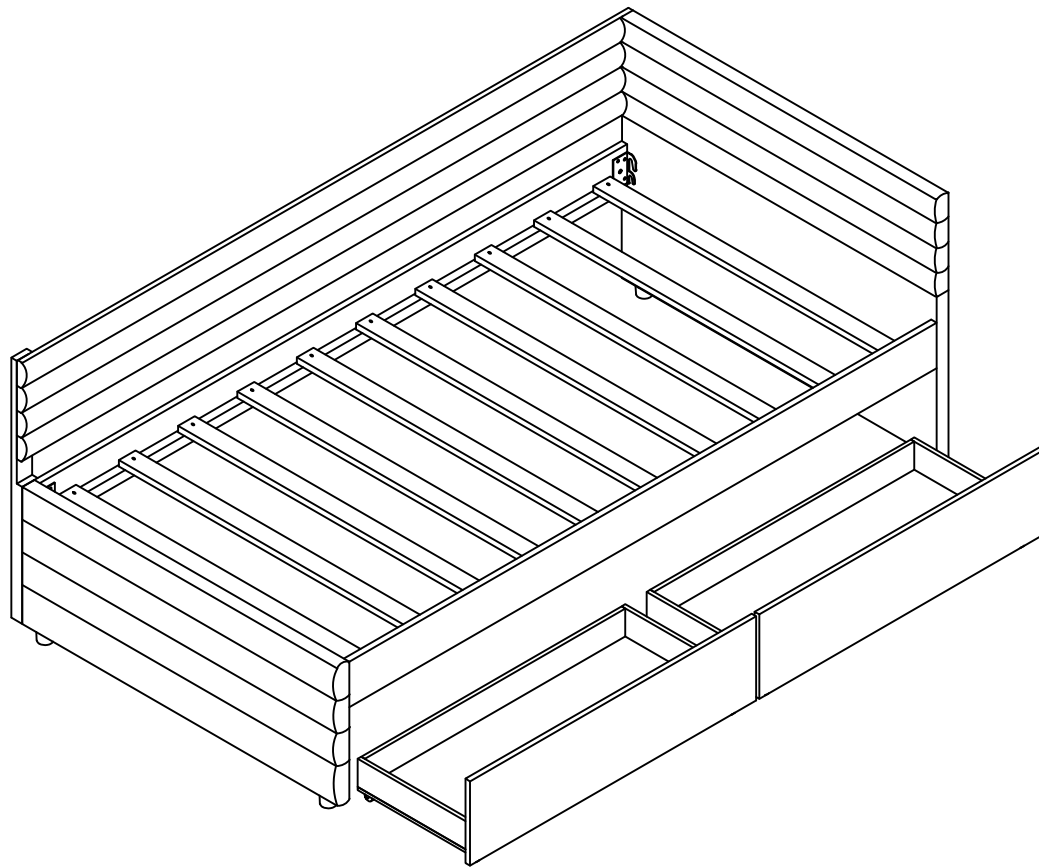

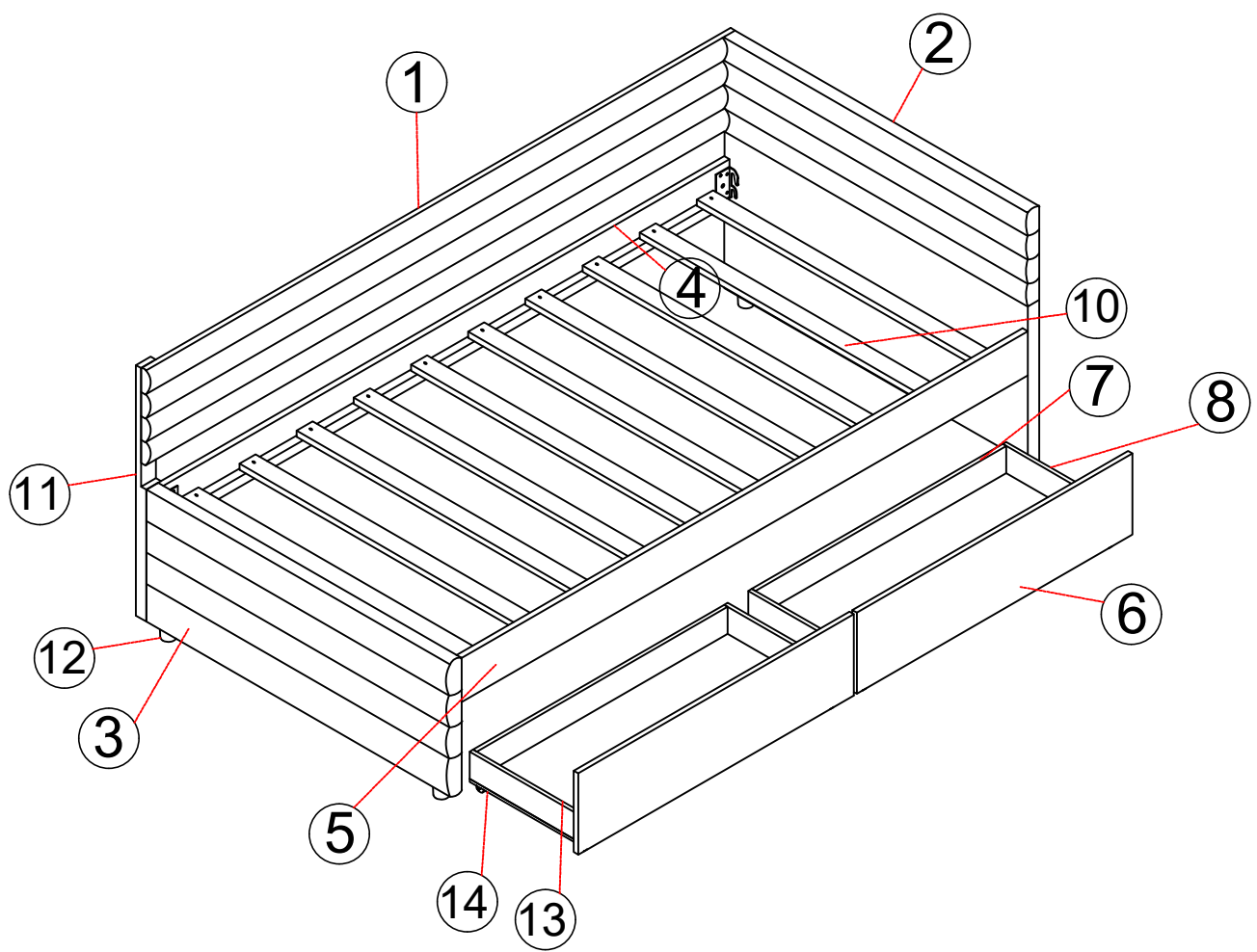



Part List

(Liste des pièces)



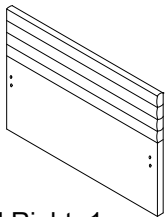
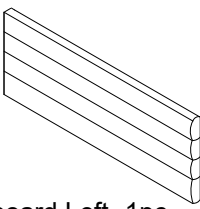
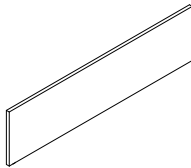
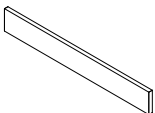
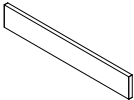

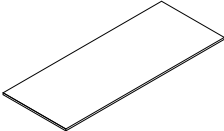
BOX 1/2: N709P204629K/ N709P204629H

ENCADRÉ 1/2 :N709P204629K / N709P204629H

<p>2</p>  <p>Side board Right -1pc Buffet latéral Droit -1 pièce</p>	<p>3</p>  <p>Side board Left -1pc Buffet latéral gauche - 1 pièce</p>	<p>6</p>  <p>in front of the drawer - 02 pc (devant le tiroir - 02pc)</p>
<p>7</p>  <p>behind the drawer- 2 pcs derrière le tiroir - 2 PCS</p>	<p>8</p>  <p>drawer side - 04 pc (côté tiroir -04pc)</p>	<p>10</p>  <p>Slates-10pcs BARRES DE SUPPORT - 10 PCS</p>
<p>11</p>  <p>connecting rod -1pc bielle - 1 pièce</p>	<p>13</p>  <p>drawer bottom-2pcs fond de tiroir - 2 PCS</p>	

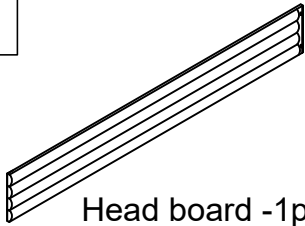
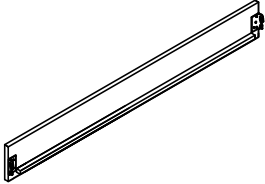
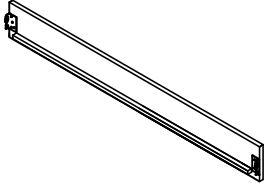
BOX 2/2: N709P204630K / N709P204630H

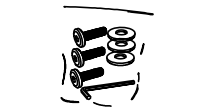







ENCADRÉ 1/2 : N709P204630K / N709P204630H

<p>1</p>  <p>Head board -1pc Tête de lit - 1 pièce</p>	<p>4</p>  <p>Back Rails -1pc Dos de barrière - 1 pièce</p>	<p>5</p>  <p>Front Rails -1pc Rails avant - 1 pièce</p>
<p>12</p>  <p>Legs - 4pcs (JAMBE-4pcs)</p>	<p>Hardware (Matériel)</p> 	<p>14</p>  <p>Wheel support -8pcs Support de roue - 8 pièce</p>

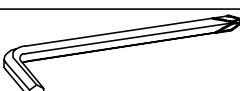
HARDWARE

Check that you've received
all hardware listed below.

Hardware List (Liste du matériel)

No.	OUTLOOK (PERSPECTIVES)	NOTE	QTY
(A)		Bolts 5/16"x35 mm (Boulons 5/16"x35 mm)	6
(B)		Bolts 5/16"x30 mm (Boulons 5/16"x30 mm)	14
(C)		Spring washer Ø5/16"x12 mm (Rondelle élastiquer Ø5/16"x12 mm)	14
(D)		Allen key 80x25x4 mm (clé Alle`n 80x25x4 mm)	1
(E)		Bolts 5/16"x30 mm (Boulons 5/16"x30 mm)	8
(F)		Screws Ø4x30 mm (Des vis Ø4x30 mm)	20
(G)		Screws Ø4x15 mm (Des vis Ø4x15 mm)	72
(M)		Screws Ø4x10 mm (Des vis Ø4x10 mm)	24
(I)		LINKED METAL (MÉTAL LIÉ)	6
(H)		Wheel (Roue)	8

STEP 1 (ÉTAPE 1)

12x2	E x 4	B x 4	C x 4

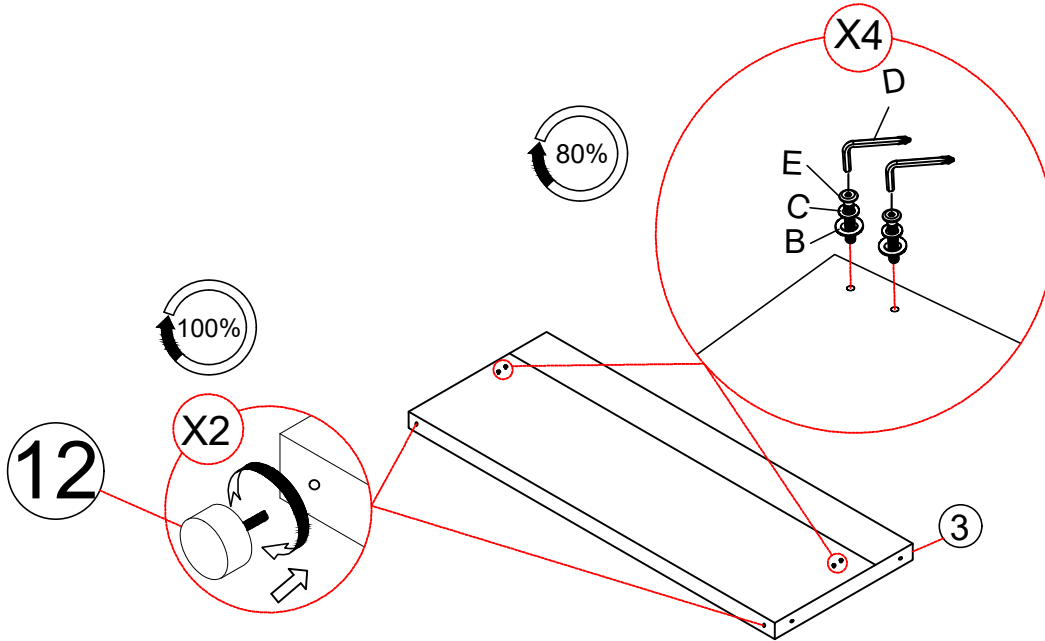

STEP 2 (ÉTAPE 2)

12x2	E x 4	B x 4	C x 4

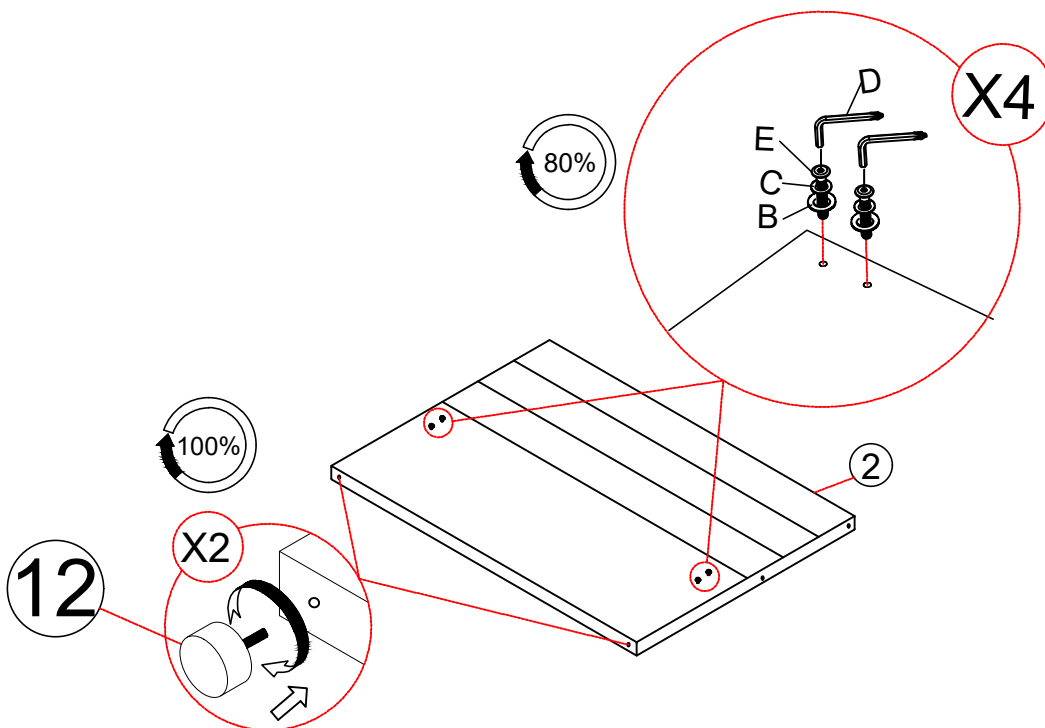

STEP 3

(ÉTAPE 3)

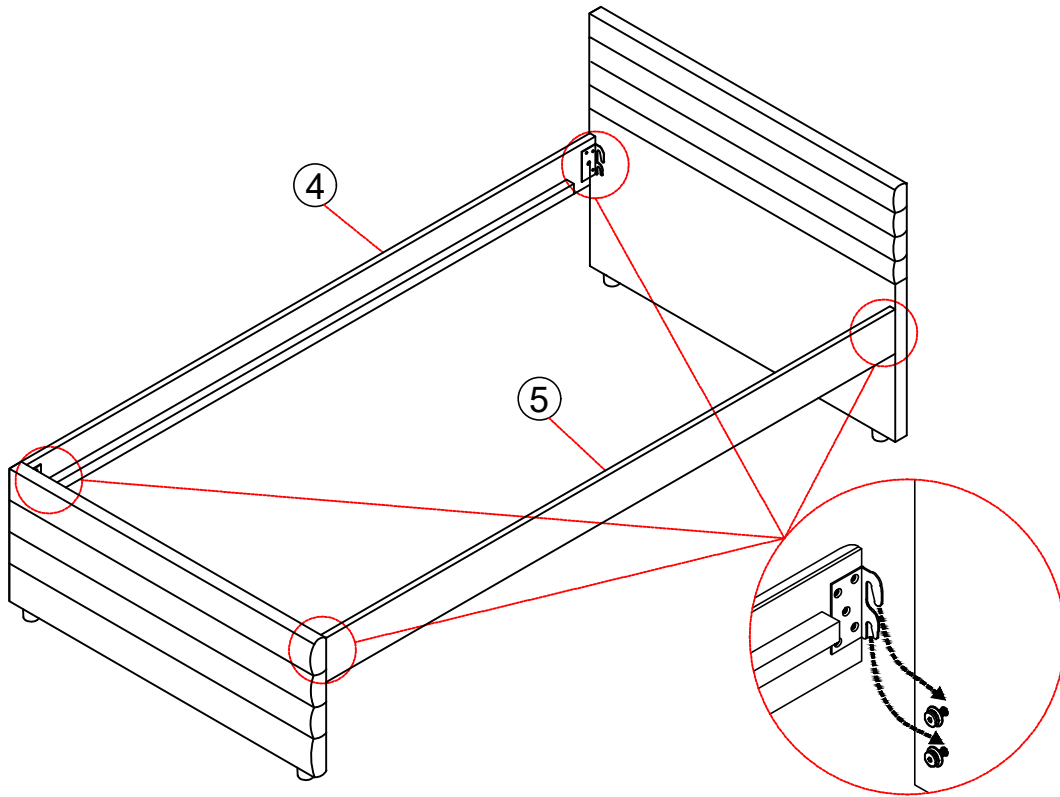

STEP 4

(ÉTAPE 4)

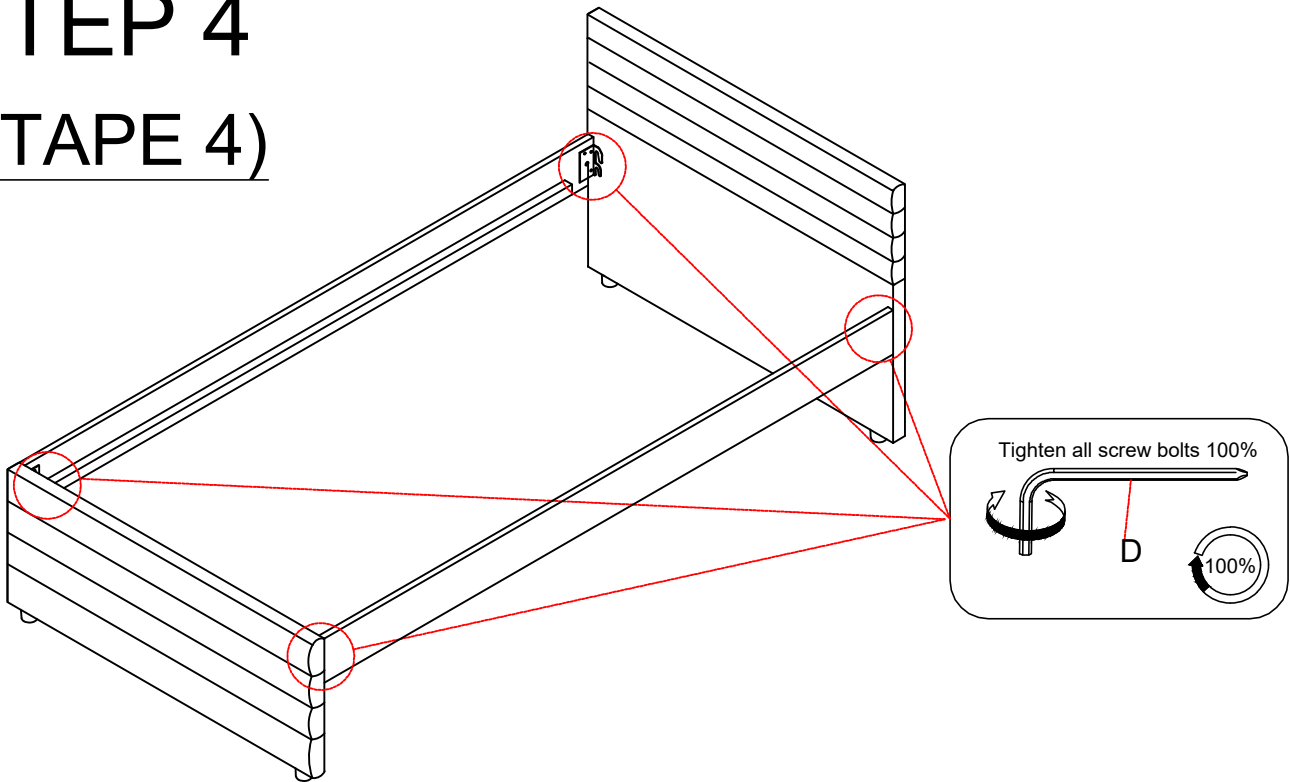

STEP 5 (ÉTAPE 5)

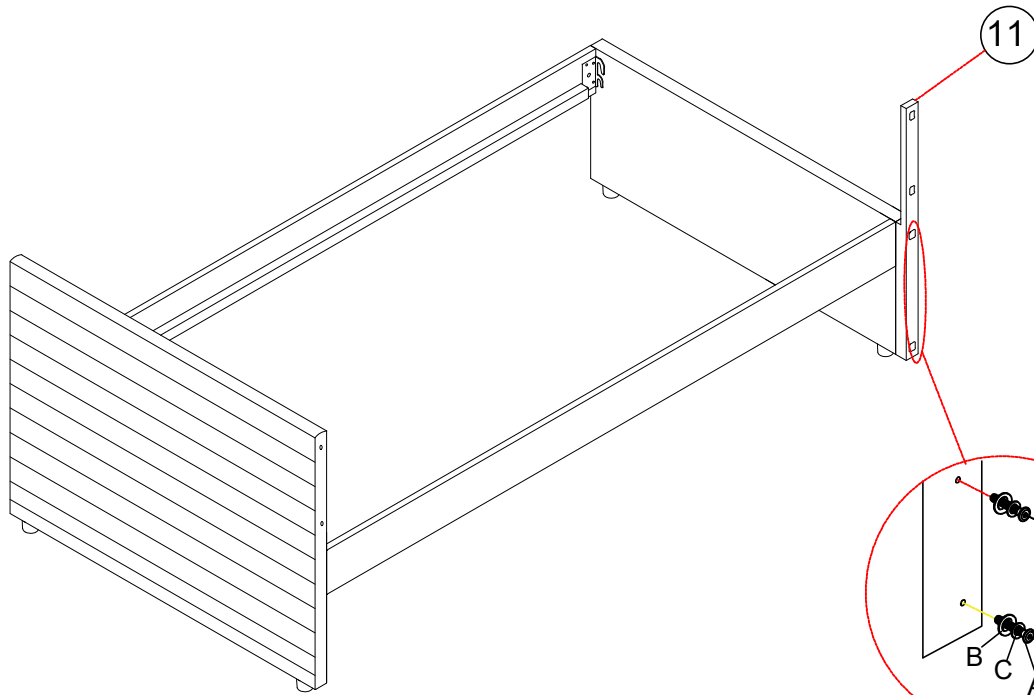
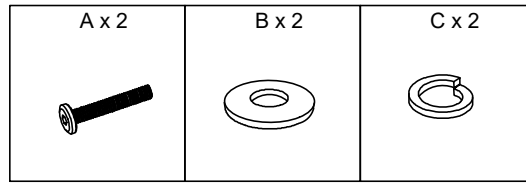

STEP 6 (ÉTAPE 6)

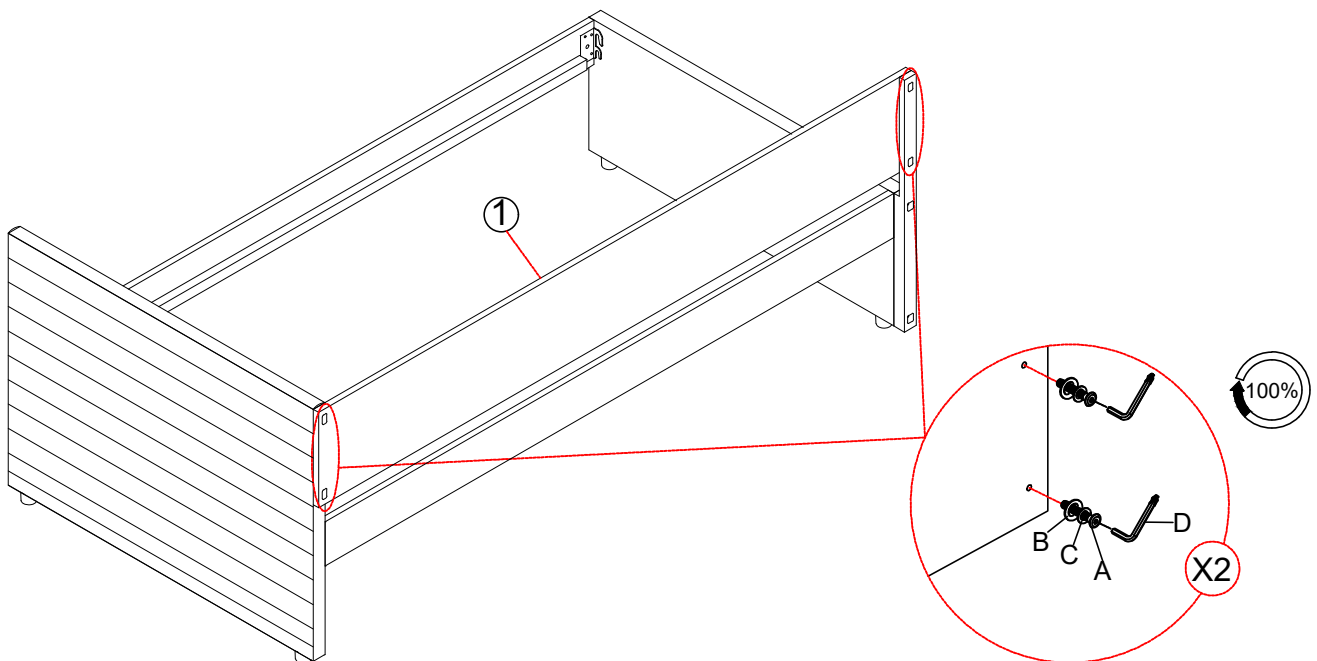
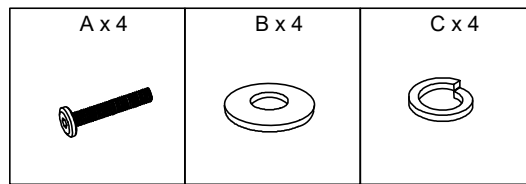

STEP 7 (ÉTAPE 7)

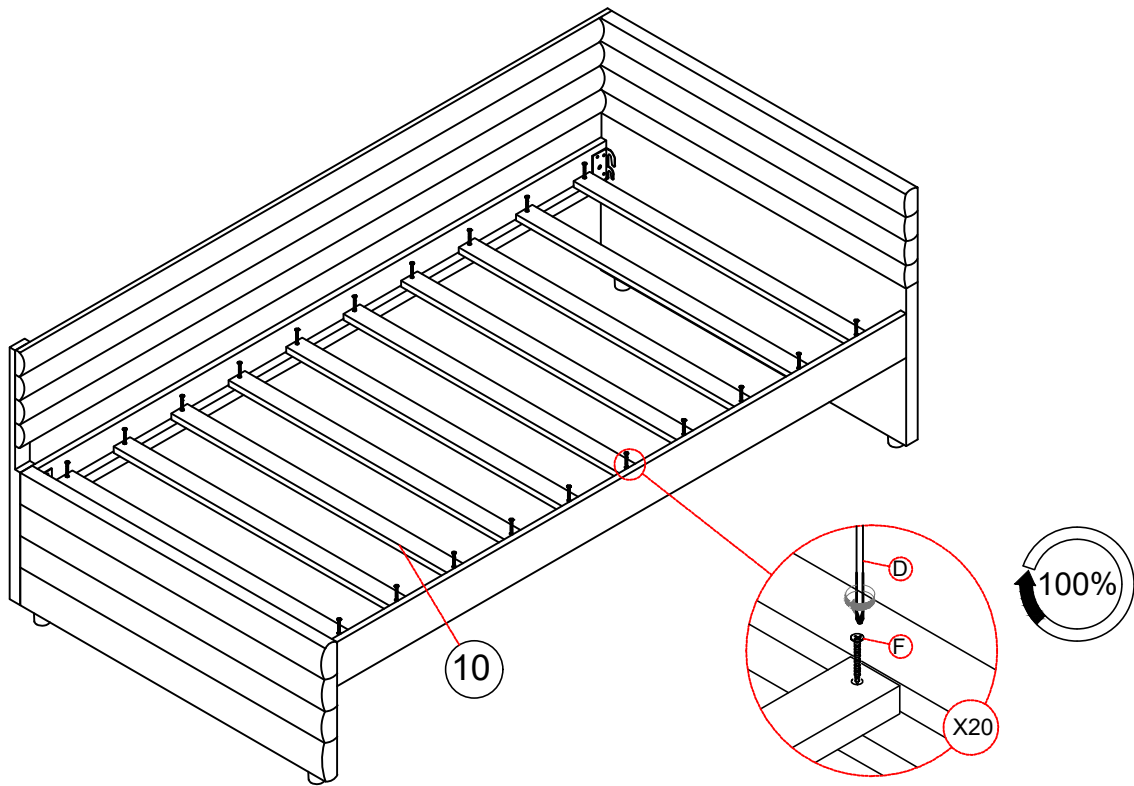
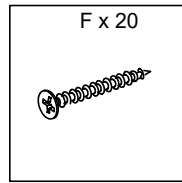

STEP 8 (ÉTAPE 8)

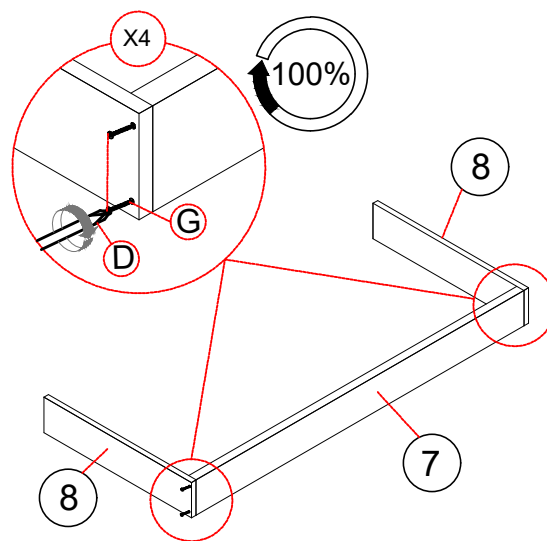
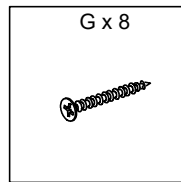

DO THE SAME WITH THE REMAINING DRAWER
FAITES DE MÊME AVEC LE COMPARTIMENT RESTANT

STEP 9 (ÉTAPE 9)

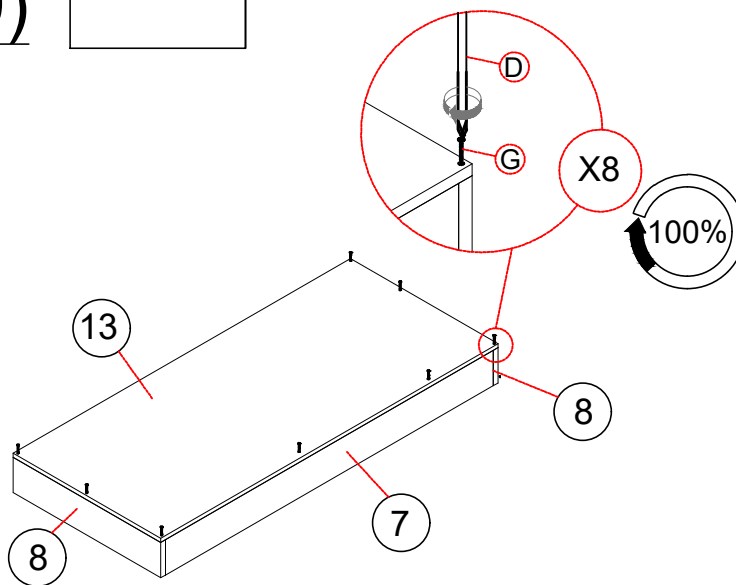
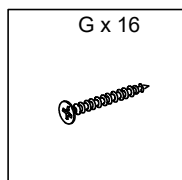

DO THE SAME WITH THE REMAINING DRAWER
FAITES DE MÊME AVEC LE COMPARTIMENT RESTANT

STEP 10 (ÉTAPE 10)

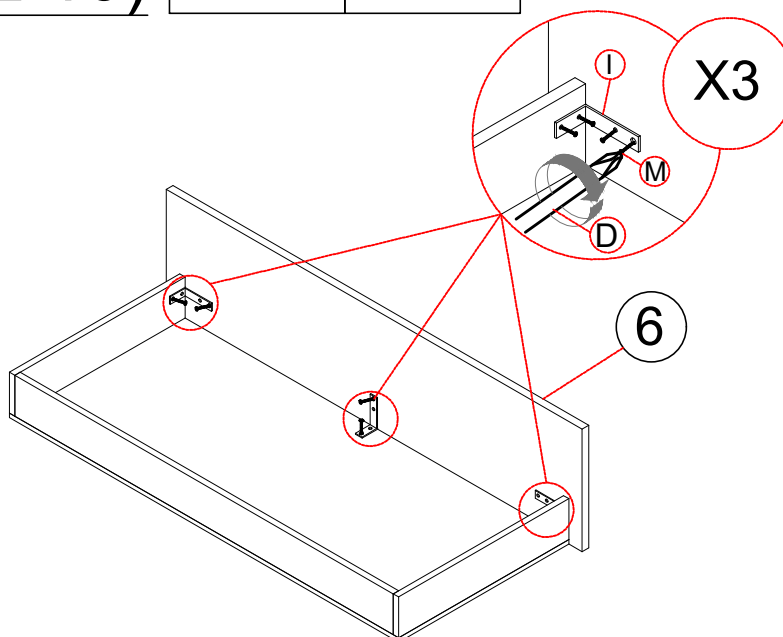
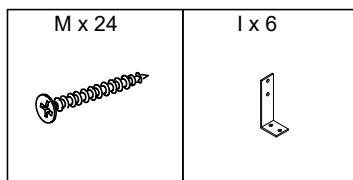

DO THE SAME WITH THE REMAINING DRAWER
FAITES DE MÊME AVEC LE COMPARTIMENT RESTANT

STEP 11 (ÉTAPE 11)

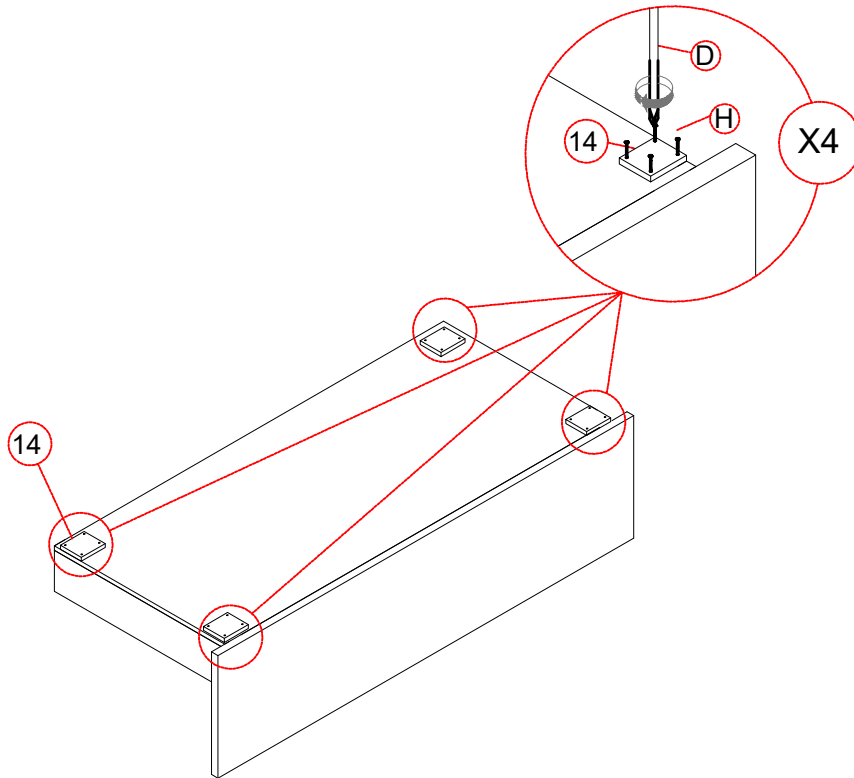
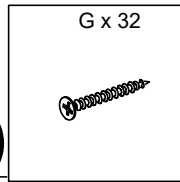

DO THE SAME WITH THE REMAINING DRAWER
FAITES DE MÊME AVEC LE COMPARTIMENT RESTANT

STEP 12 (ÉTAPE 12)

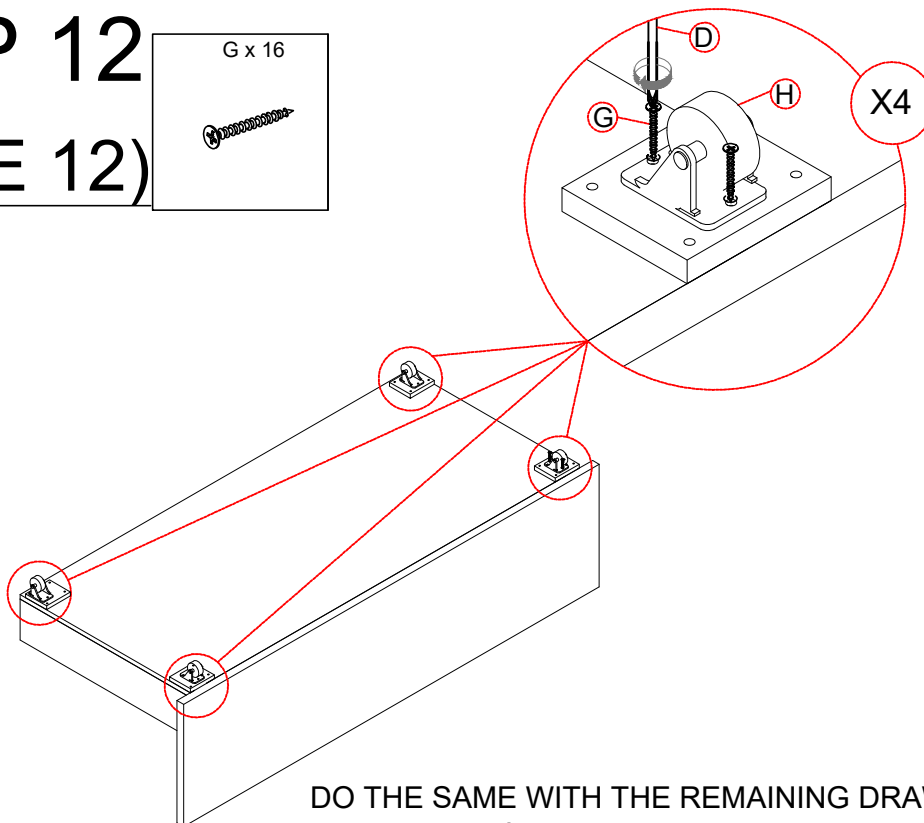
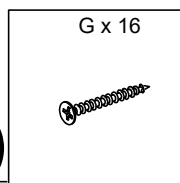

DO THE SAME WITH THE REMAINING DRAWER
FAITES DE MÊME AVEC LE COMPARTIMENT RESTANT

STEP 13

(ÉTAPE 13)

