

Storage Cabinet

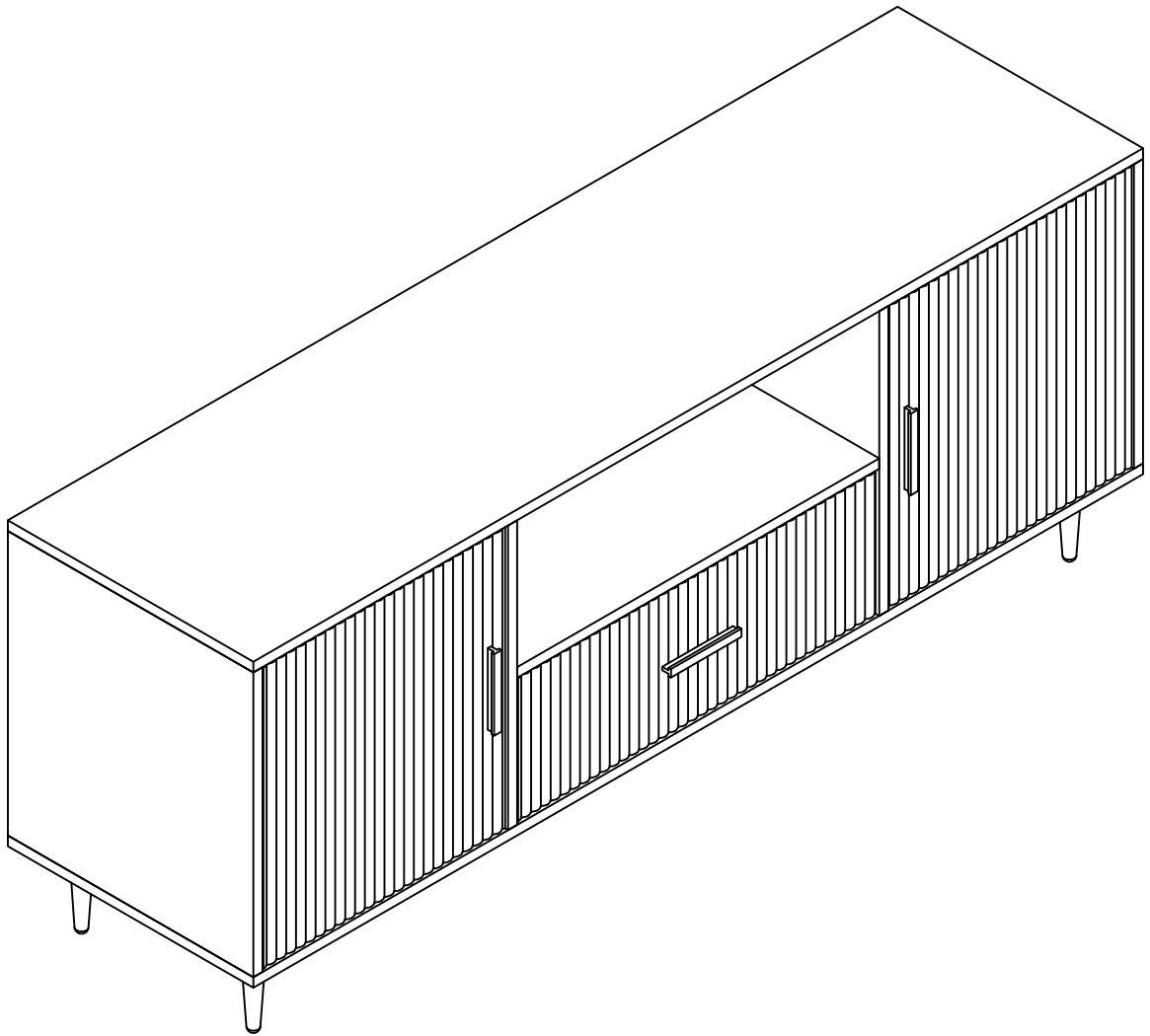

Made in China

WARNING

Serious or fatal injury may occur from unexpected assembly or use.

1. During the assembly process, keep all parts away from babies or children.
2. Always securely fix this product to the wall. Make sure the wall area to be drilled is free from hidden electrical wires, water and gas pipes.
3. Use of tip-over restraints may only reduce, but not eliminate the risk of tip-over.
4. Unless specially designed to accommodate, do not set heavy objects on top of this product.
5. Place the heaviest items on the lowest shelf.
6. Never allow children to climb or bang on drawers, doors or shelves.

WARNING



Children have died from furniture tipover. To reduce the risk of furniture tipover:

- **ALWAYS** install tipover restraint provided.
- **NEVER** allow children to stand, climb or hang on drawers, doors, or shelves.
- **NEVER** open more than one drawer at a time.
- **Place heaviest items in the lowest drawers.**

Parts List (EN) / Teile Liste (DE)

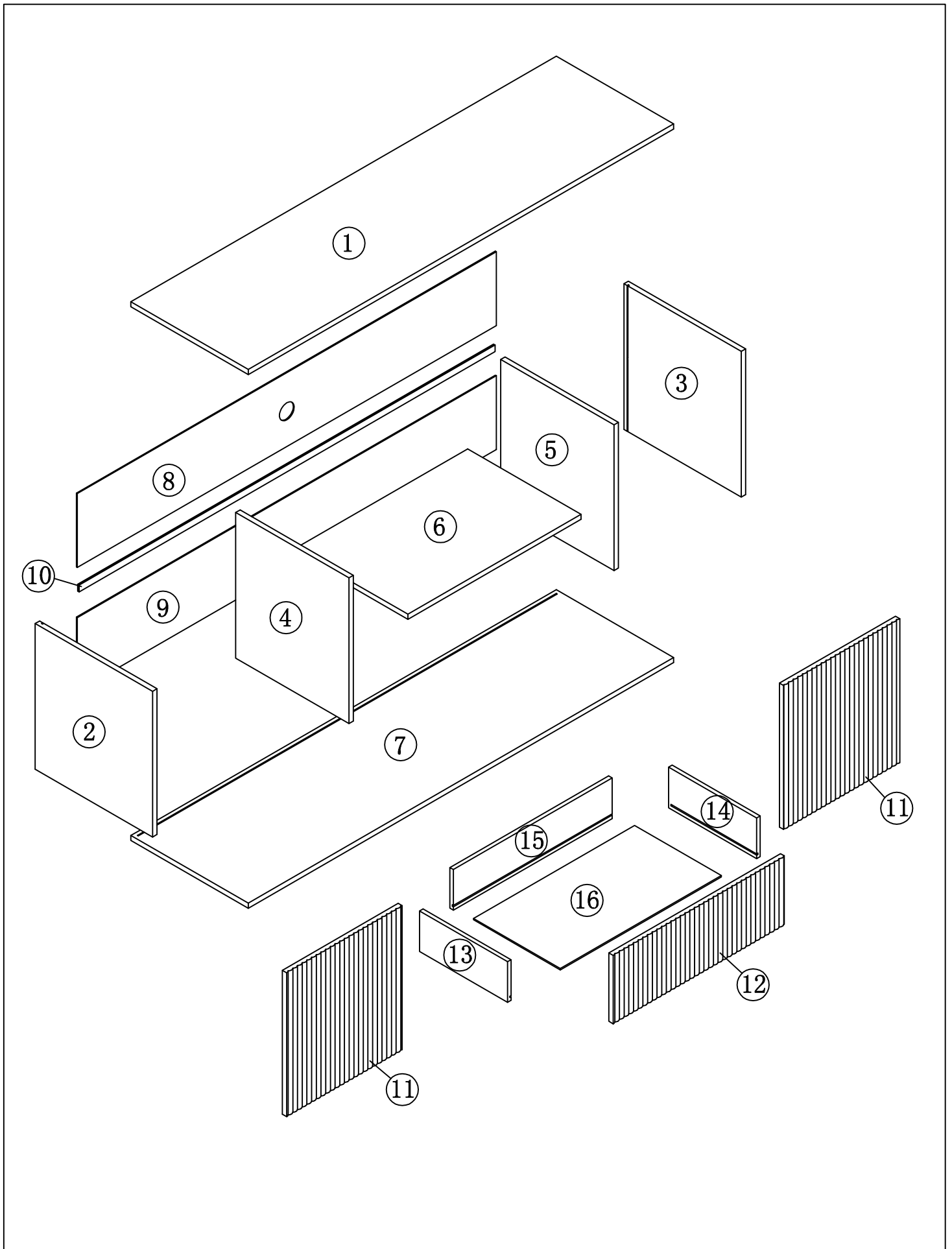

Parts List (EN) / Teile Liste (DE)

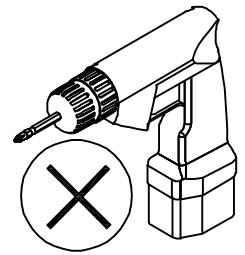
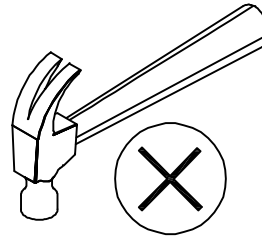
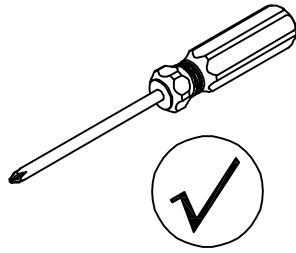
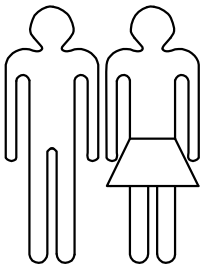

<p>①</p> <p>1452*400*15mm</p>	<p>②</p> <p>430*399*15mm</p> <p>1PC</p>
<p>③</p> <p>430*399*15mm</p> <p>1PC</p>	<p>④</p> <p>one side the other side</p> <p>430*384*15mm</p> <p>1PC</p>
<p>⑤</p> <p>one side the other side</p> <p>430*384*15mm</p> <p>1PC</p>	<p>⑥</p> <p>590*384*15mm</p> <p>1PC</p>
<p>⑦</p> <p>one side</p> <p>1452*400*15mm</p>	<p>the other side</p> <p>1PC</p>
<p>⑧</p> <p>1428*218*3mm</p> <p>1PC</p>	<p>⑨</p> <p>1428*218*3mm</p> <p>1PC</p>



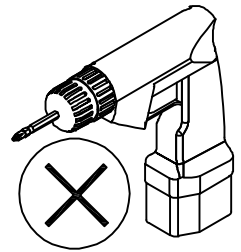
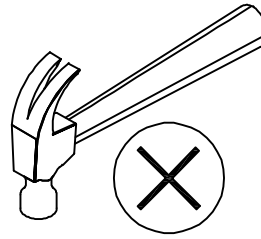
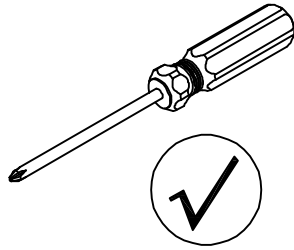
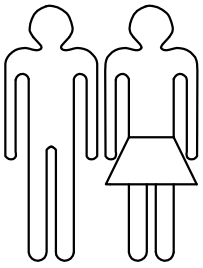

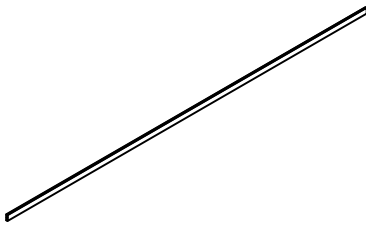
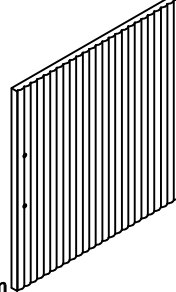
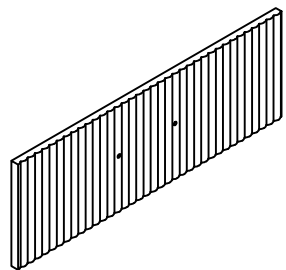
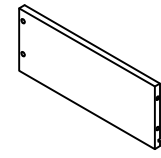
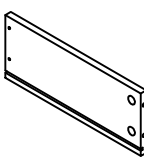
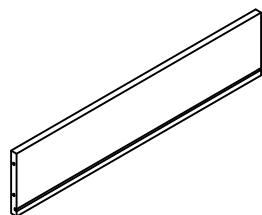
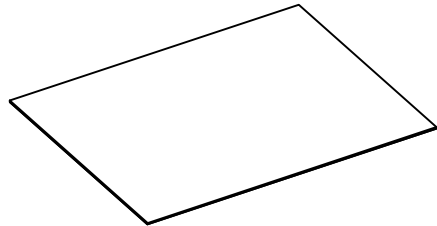

Parts List (EN) / Teile Liste (DE)

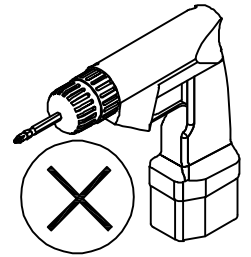
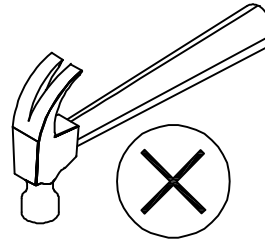
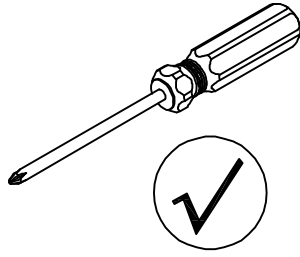
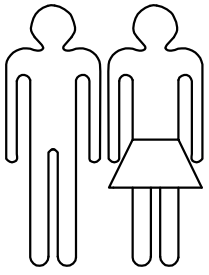

<p>⑩</p>  <p>1418mm</p> <p>1PC</p>	<p>⑪</p>  <p>425*395*15mm</p> <p>2PCS</p>
<p>⑫</p>  <p>585*202*15mm</p> <p>1PC</p>	<p>⑬</p>  <p>300*120*12mm</p> <p>1PC</p>
<p>⑭</p>  <p>300*120*12mm</p> <p>1PC</p>	<p>⑮</p>  <p>553*120*12mm</p> <p>1PC</p>
<p>⑯</p>  <p>549*295*3mm</p> <p>1PC</p>	

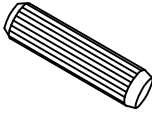
Hardware List (EN) / Teile Liste (DE)

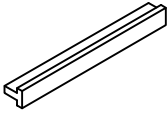
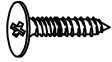
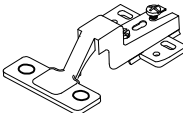

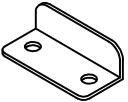
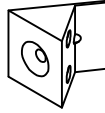
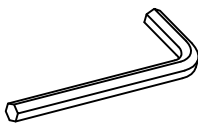
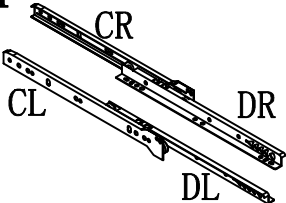
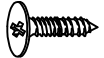
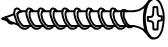
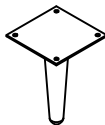
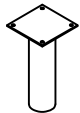
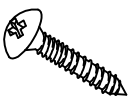
<p>A</p>  <p>Ø15*9mm 16PCS</p>	<p>B</p>  <p>Ø6*29mm 16PCS</p>	<p>C</p>  <p>Ø8*30mm 10PCS</p>	<p>D</p>  <p>M4*20mm 6PCS</p>
<p>E</p>  <p>Ø96mm 3PCS</p>	<p>F</p>  <p>Ø3*15mm 38PCS</p>	<p>G</p>  <p>Ø26mm 4PCS</p>	<p>H</p>  <p>Ø7*50mm 8PCS</p>
<p>I</p>  <p>Ø20mm 16PCS</p>	<p>J</p>  <p>29*14*9mm 2PCS</p>	<p>K</p>  <p>11*11*15mm 10PCS</p>	<p>L</p>  <p>M4 1PC</p>
<p>M</p>  <p>12" 1PC</p>	<p>N</p>  <p>Ø3*12mm 12PCS</p>	<p>O</p>  <p>Ø4*25mm 4PCS</p>	<p>P</p>  <p>120mm 4PCS</p>
<p>Q</p>  <p>116mm 1PC</p>	<p>R</p>  <p>Ø4*14mm 20PCS</p>		

Assembly (EN) / Montageschritte (DE)

CAM BOLT INSTALLATION AS BELOW:

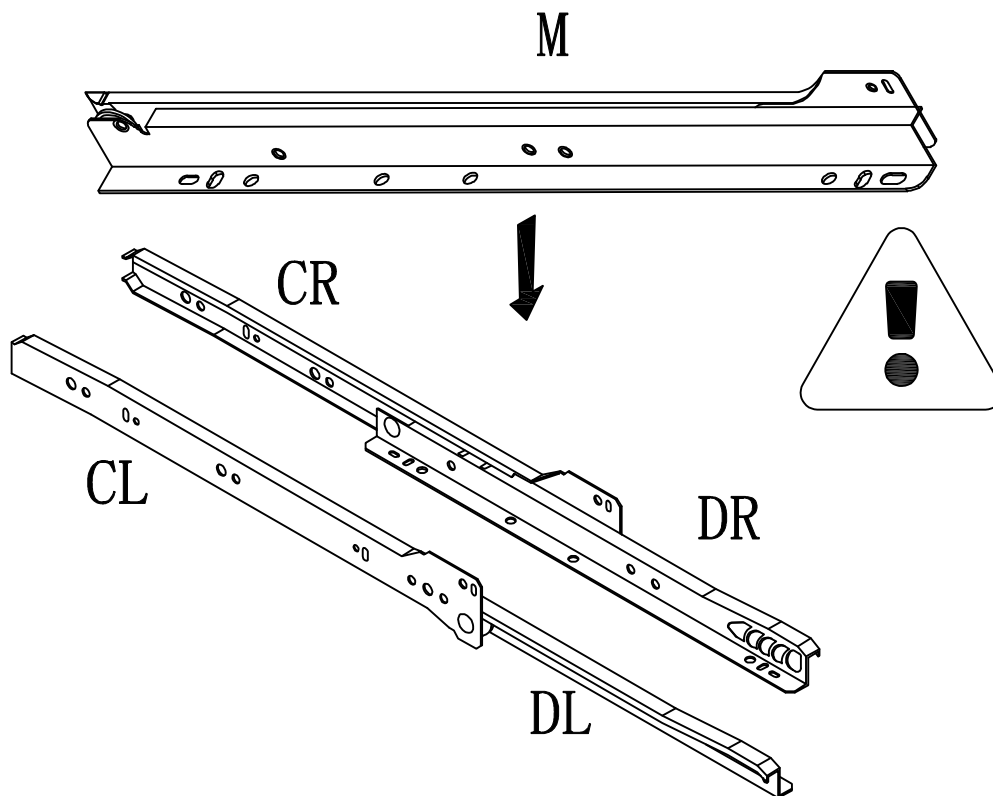
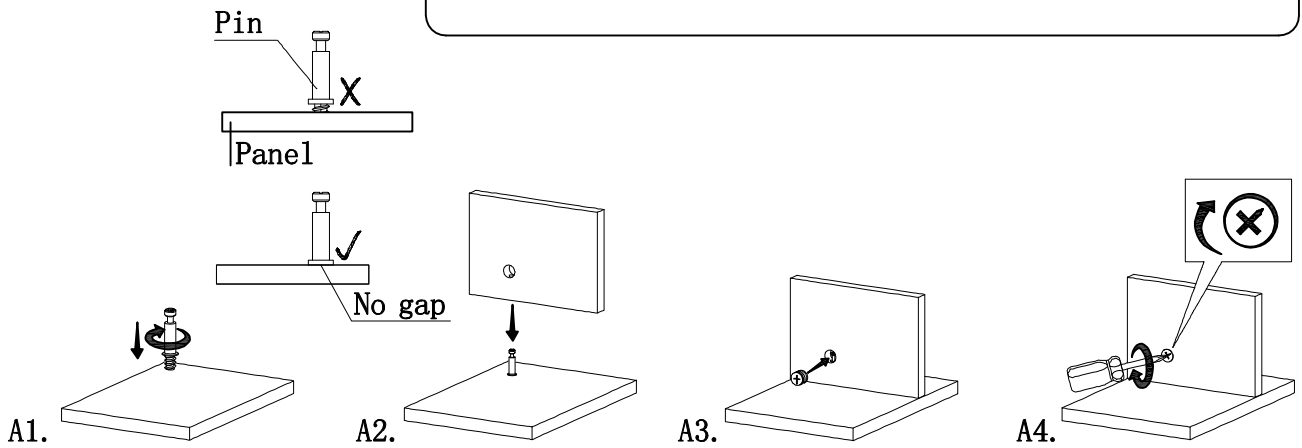
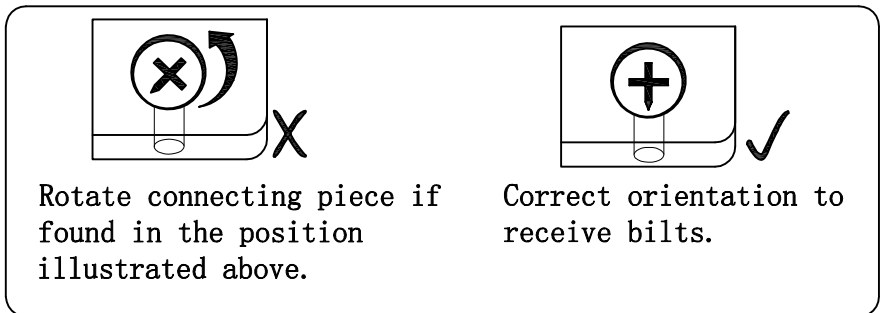
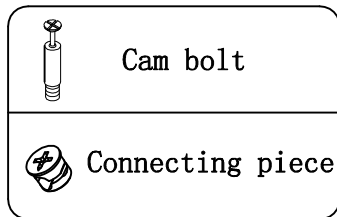



Assembly (EN) /Montageschritte (DE)

STEP 1

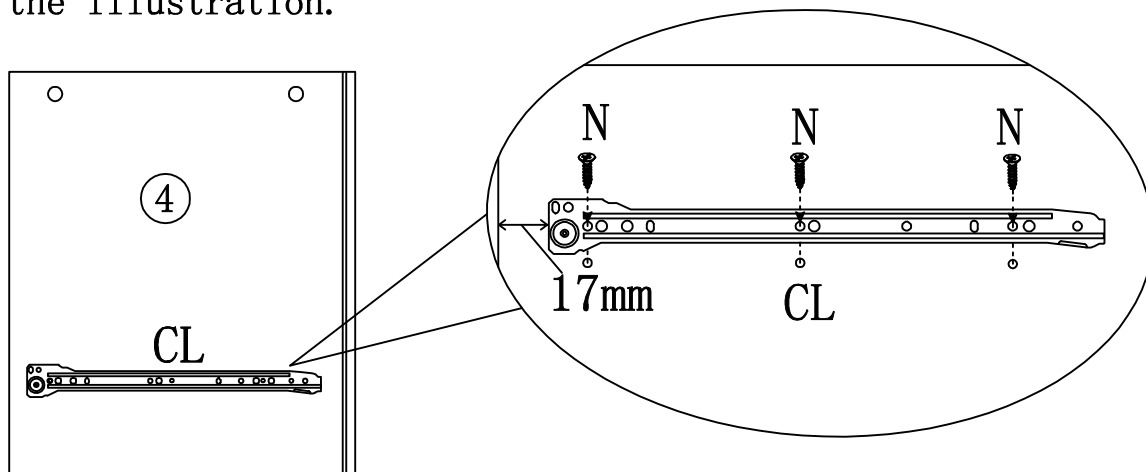
Lock the slides on to the plate according to the holes shown in the illustration.





	N * 3PCS
	CL * 1PC

STEP 2

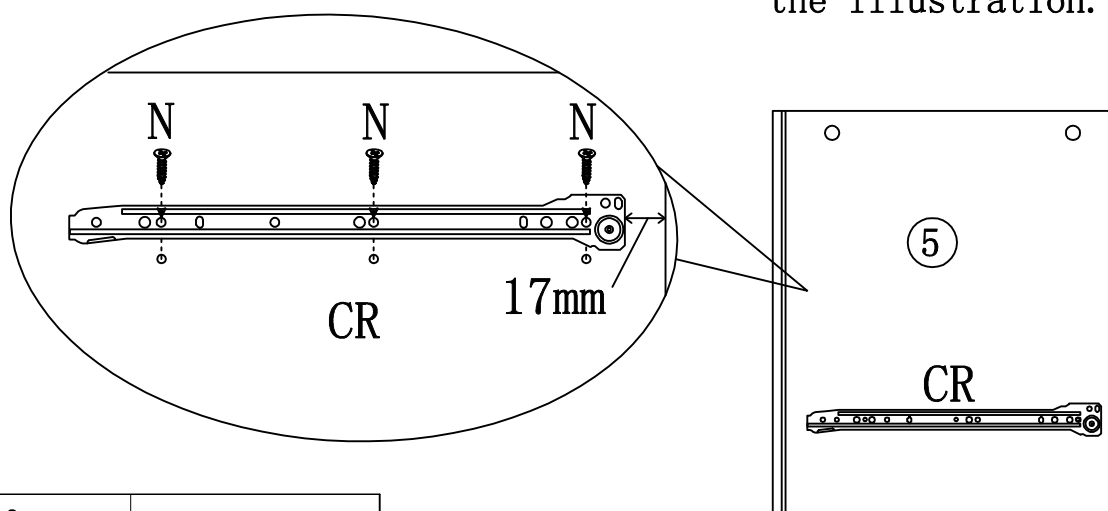
Lock the slides on to the plate according to the holes shown in the illustration.



	N * 3PCS
	CR * 1PC

Assembly (EN) / Montageschritte (DE)

STEP 3

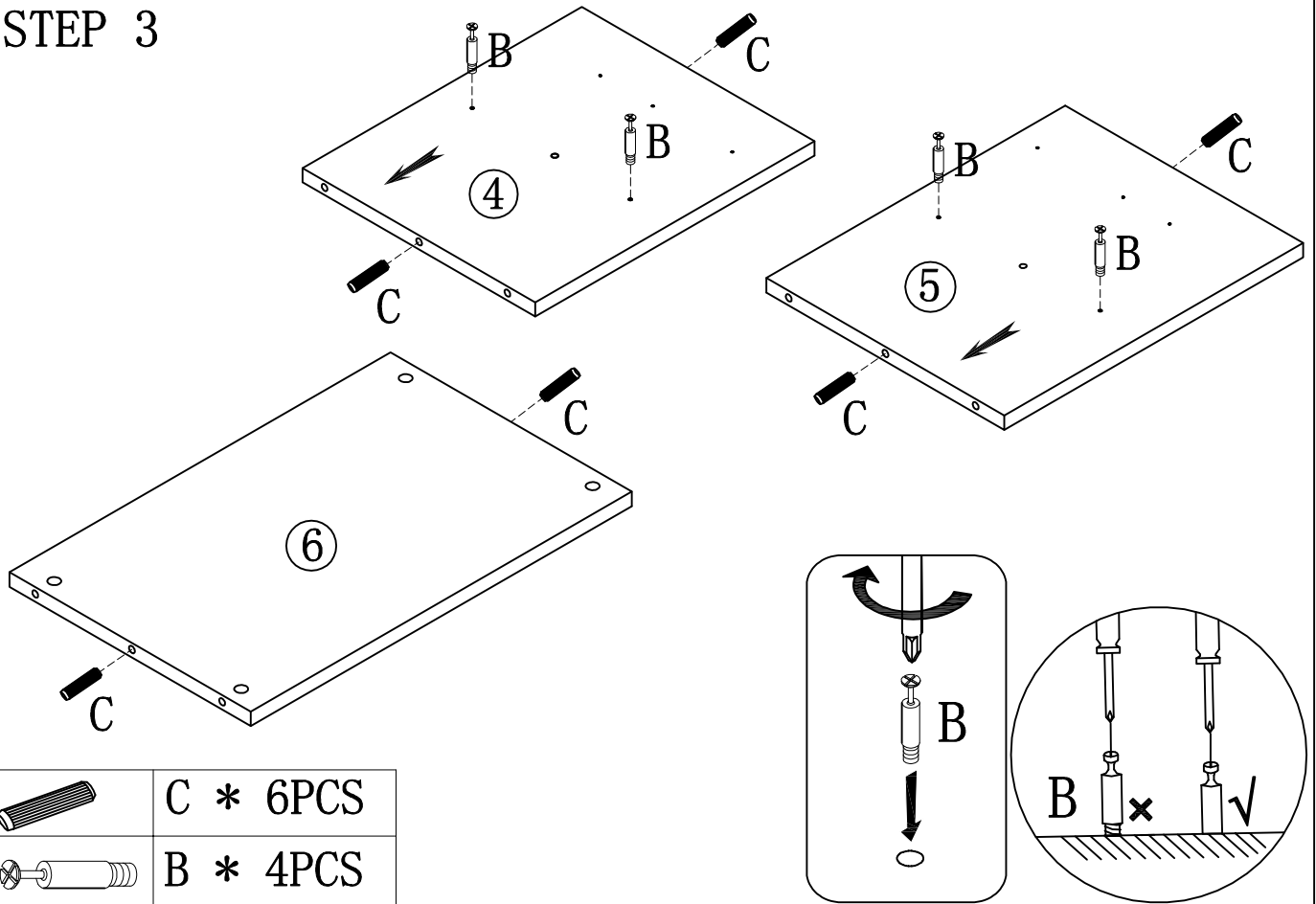

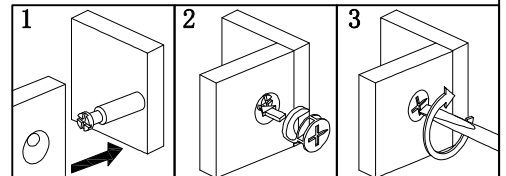
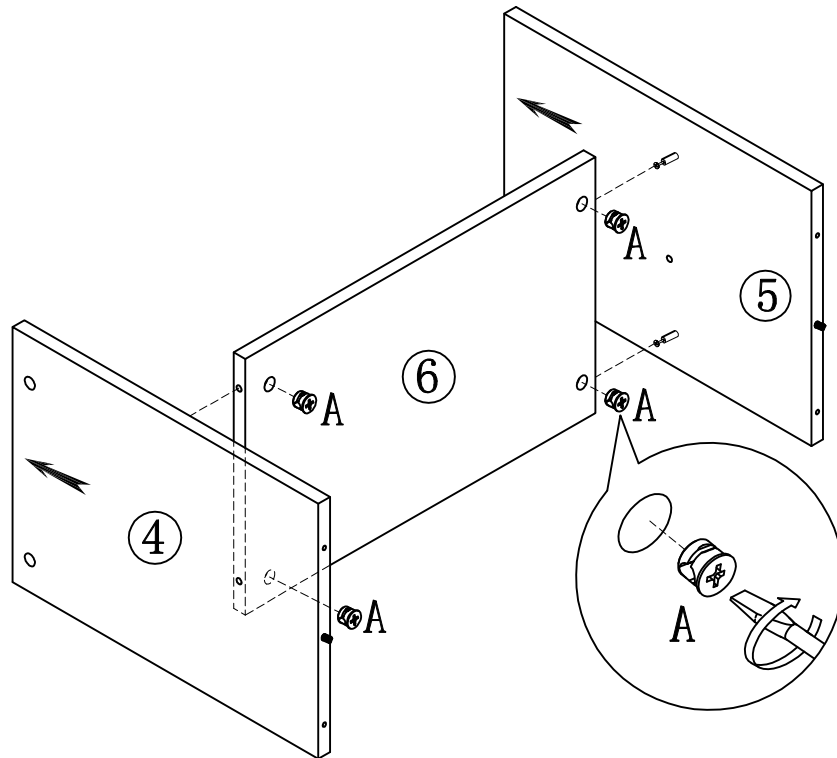

STEP 4

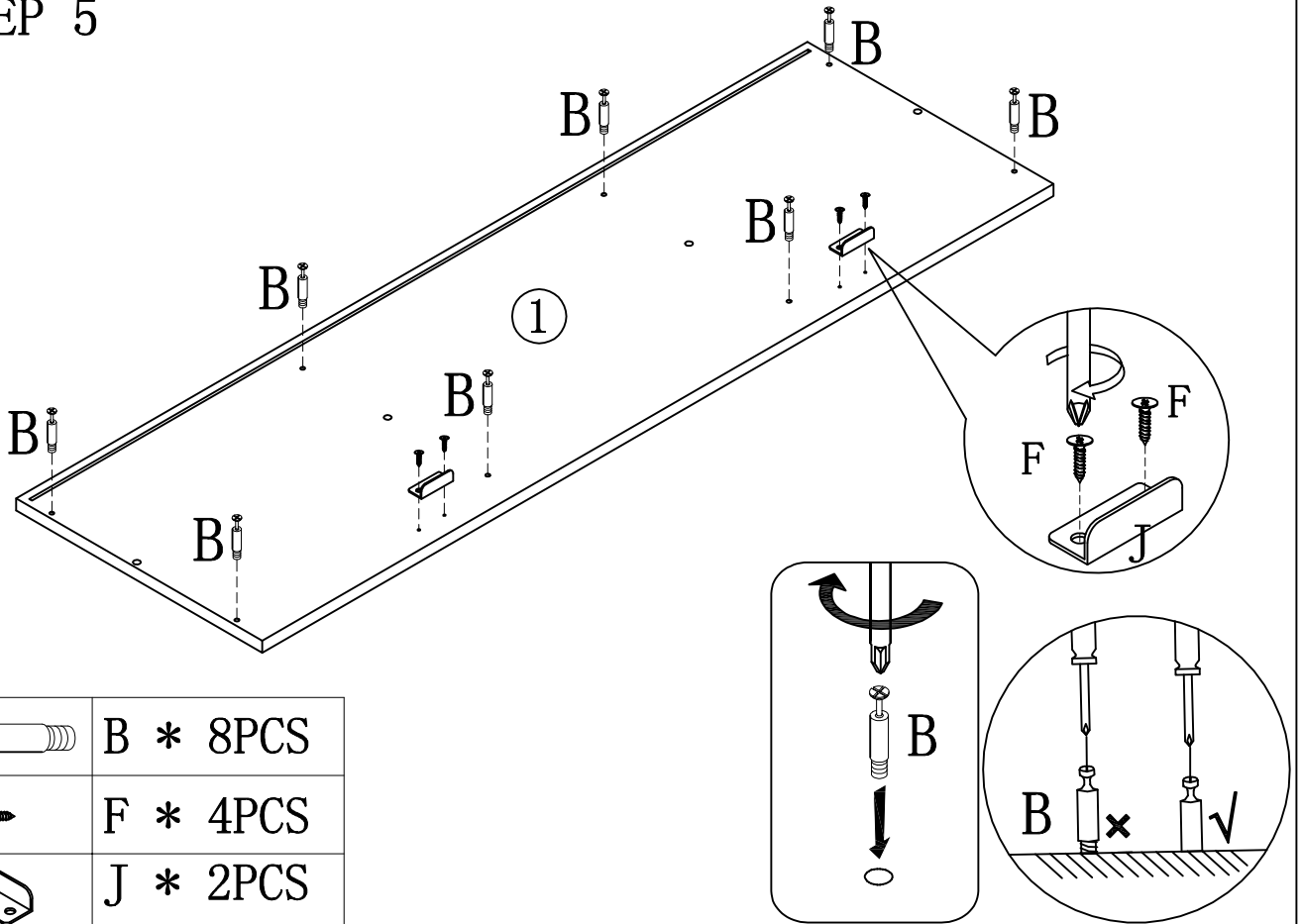

Assembly (EN) / Montageschritte (DE)

STEP 5

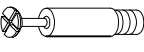

	B * 8PCS
	F * 4PCS
	J * 2PCS

STEP 6

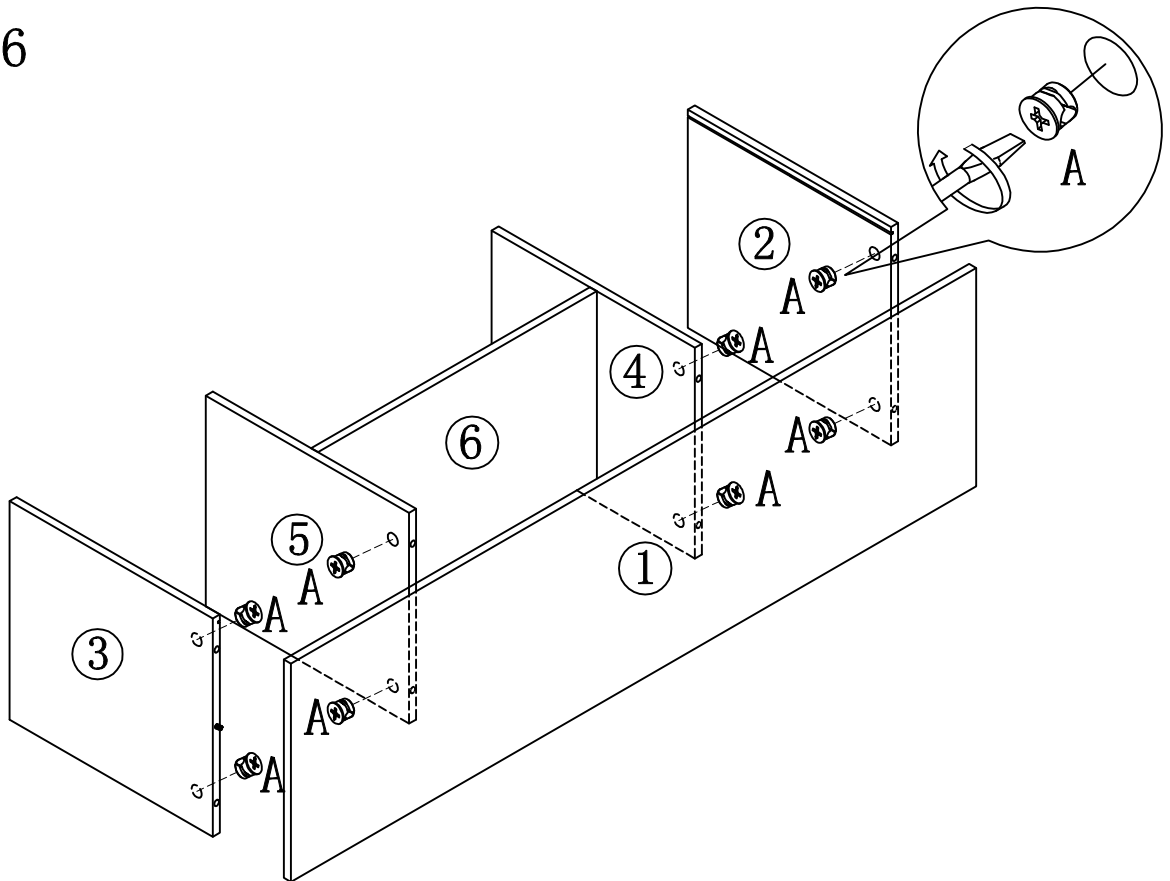

	A * 8PCS
---	----------

Assembly (EN) / Montageschritte (DE)

STEP 7

Thin back board needs to be inside the slot, otherwise blocks the opposite plate montage.

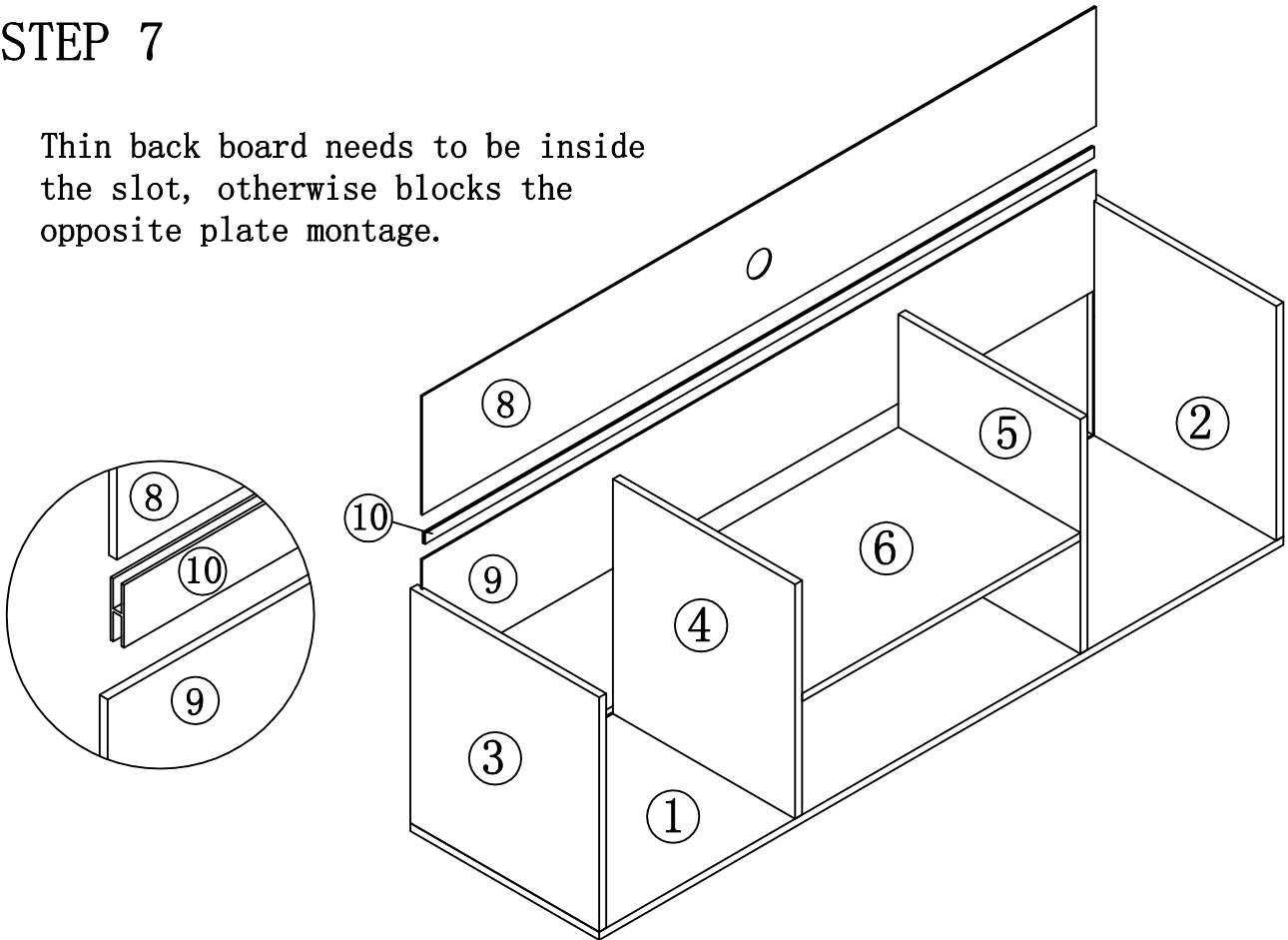

STEP 8

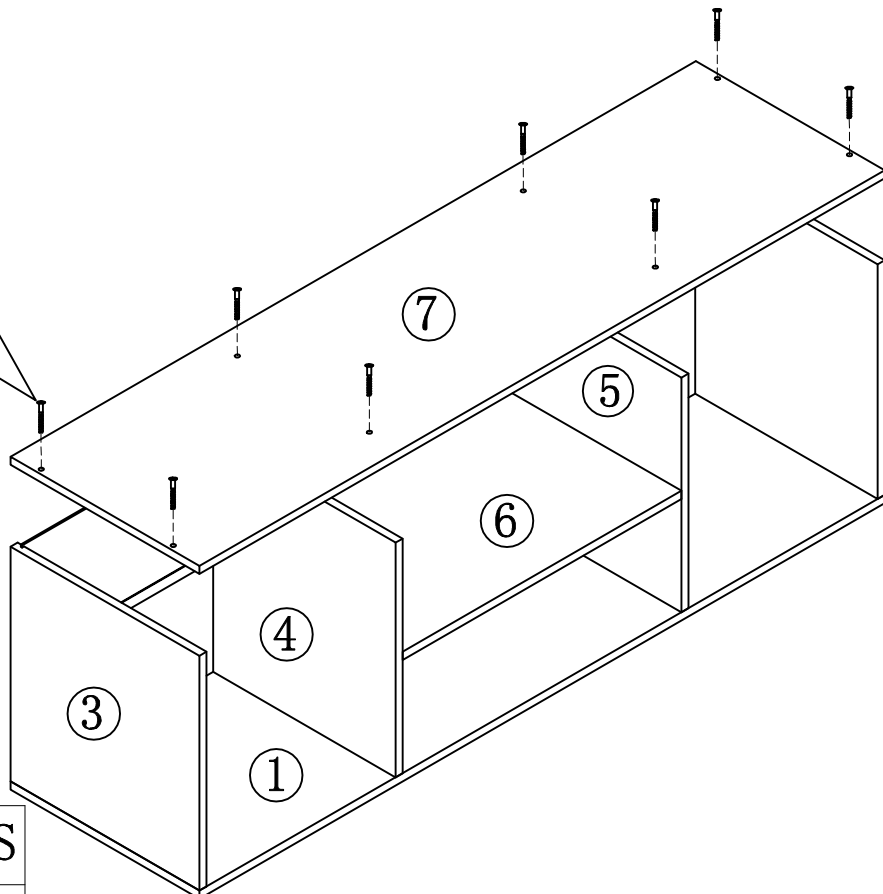
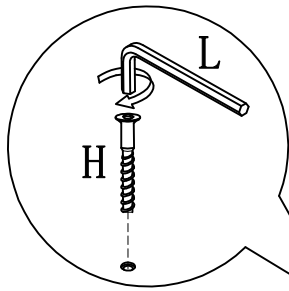

H * 8PCS





L * 1PC

Assembly (EN) / Montageschritte (DE)

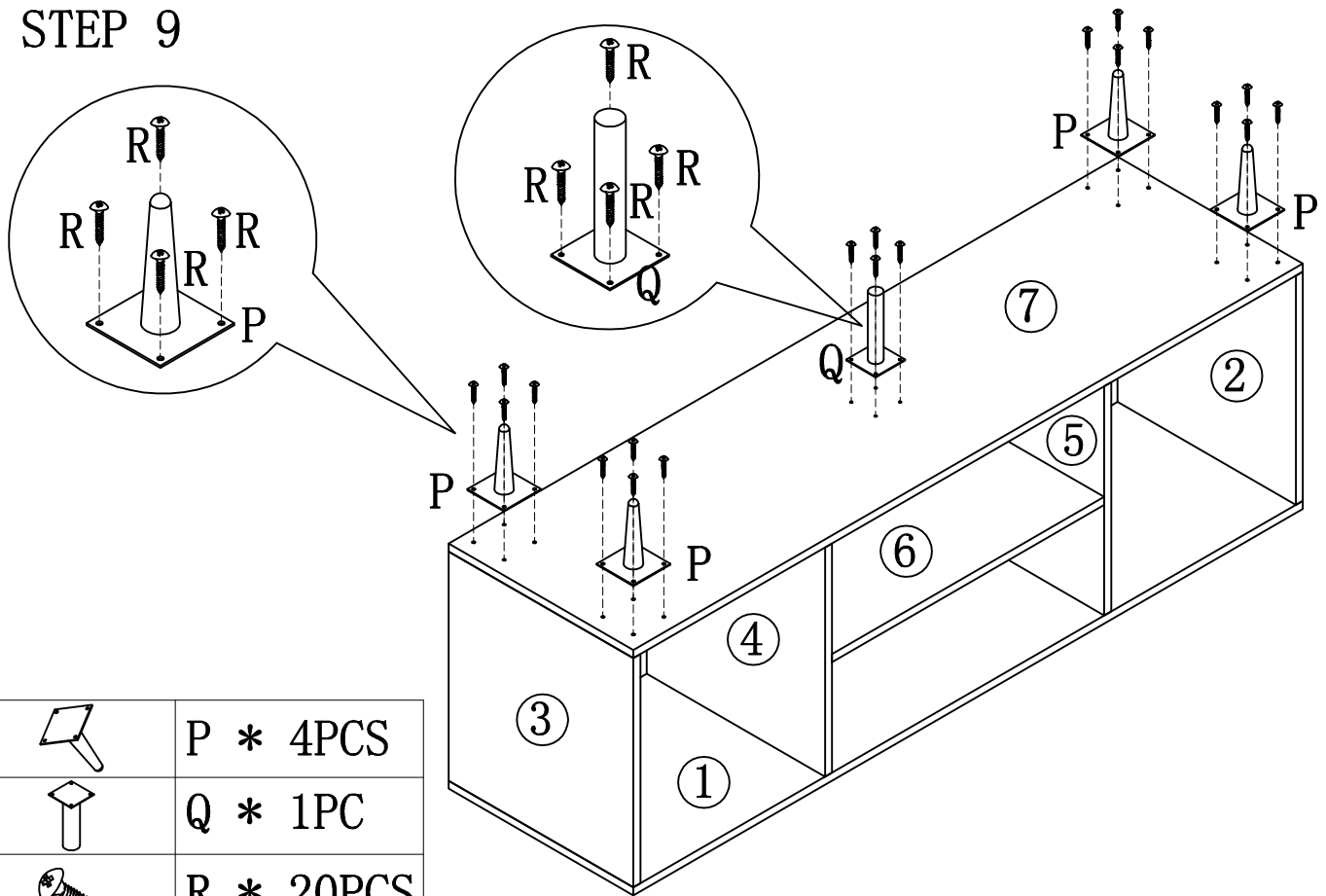

STEP 9

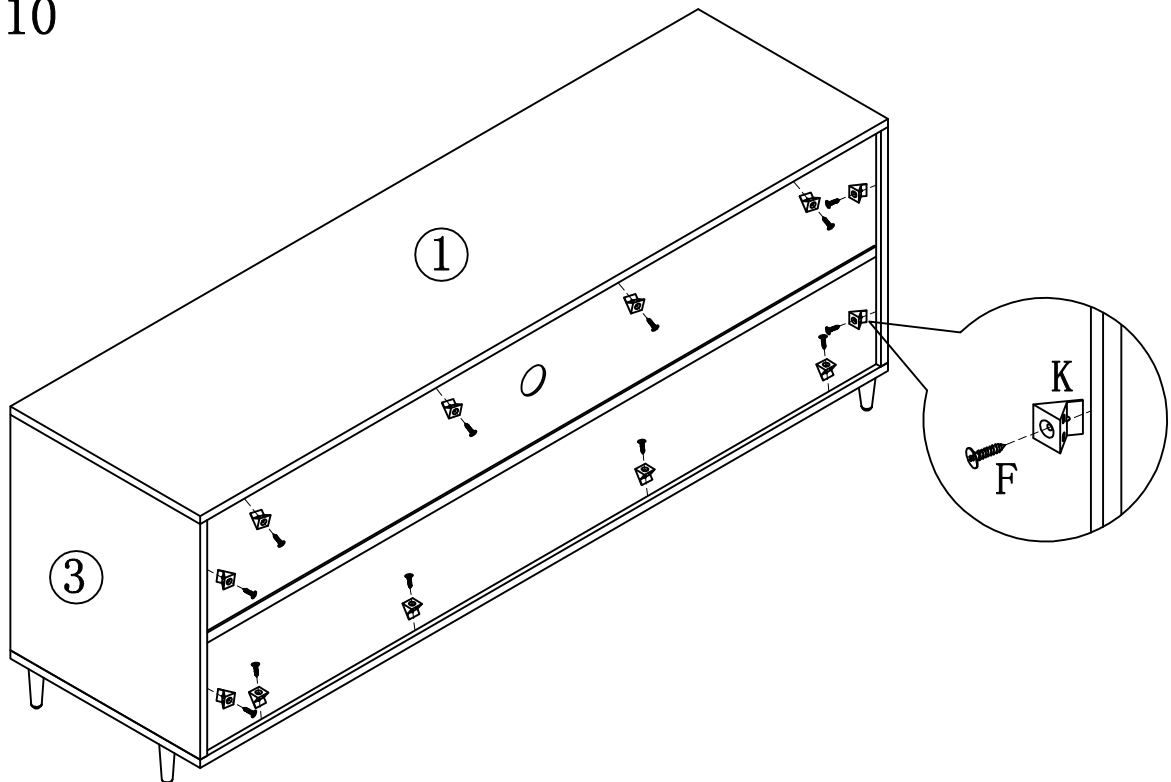

	P * 4PCS
	Q * 1PC
	R * 20PCS

STEP 10



	K * 12PCS
	F * 12PCS

Assembly (EN) /Montageschritte (DE)

STEP 11

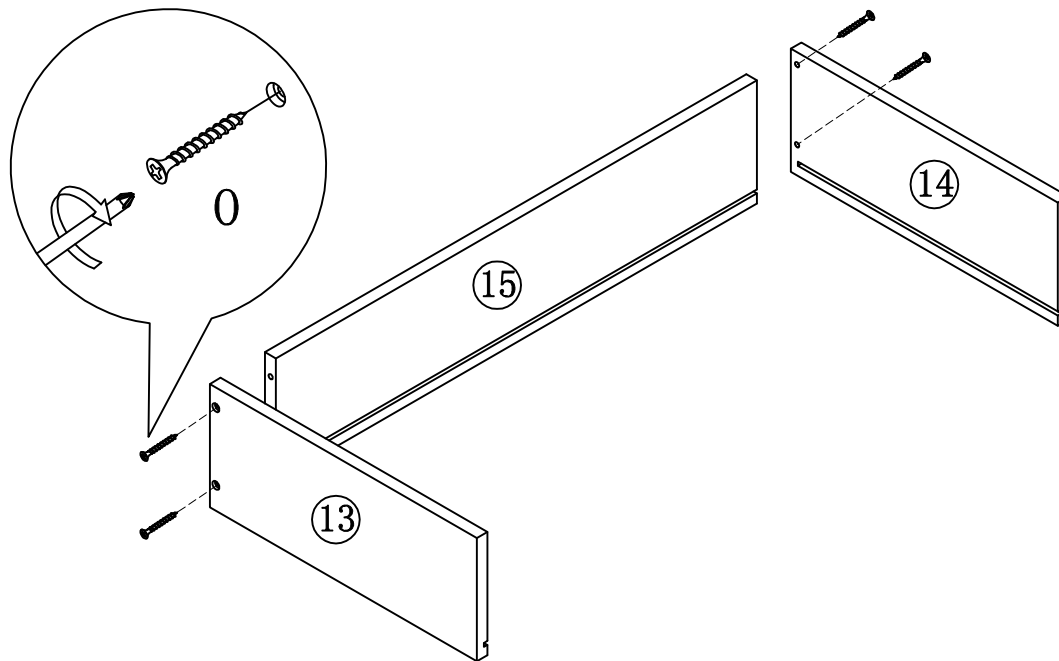

0 * 4PCS

STEP 12

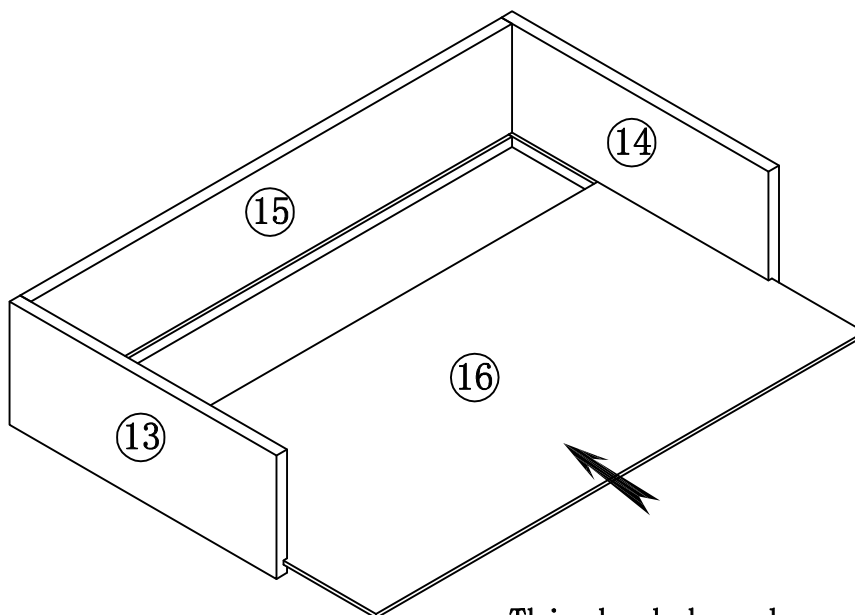



Thin back board needs to be inside the slot, otherwise blocks the opposite plate montage.

Assembly (EN) /Montageschritte (DE)

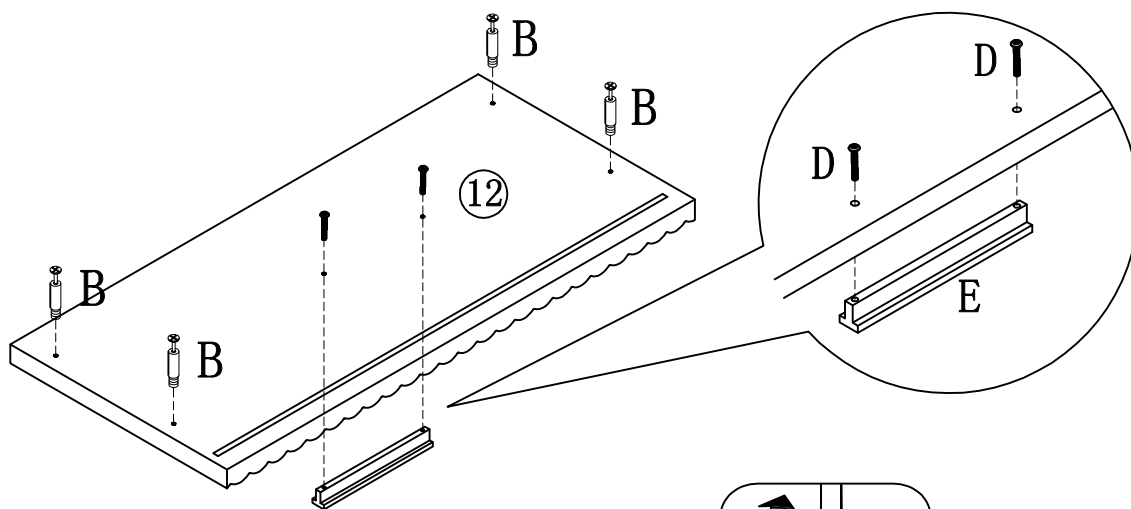
STEP 13

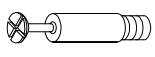

	B * 4PCS
	D * 2PCS
	E * 1PC

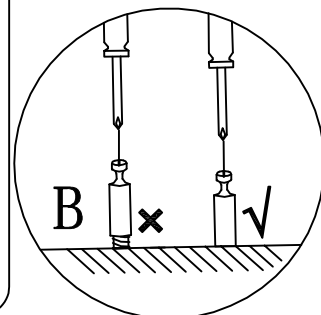
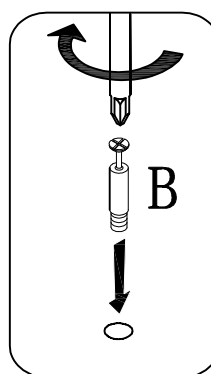

STEP 14

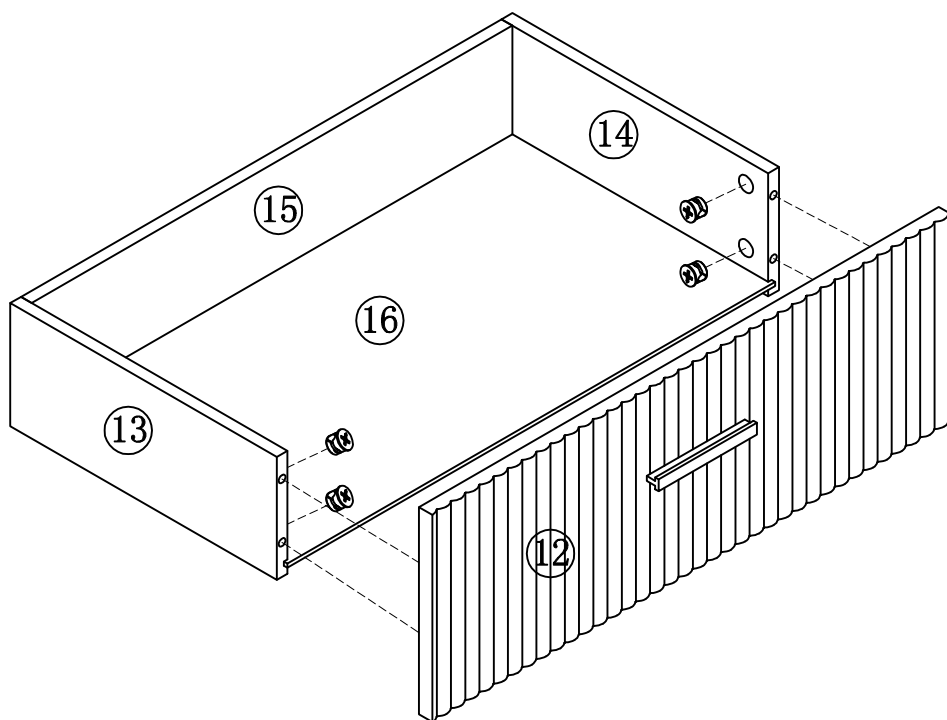



	A * 4PCS
---	----------

Assembly (EN) / Montageschritte (DE)

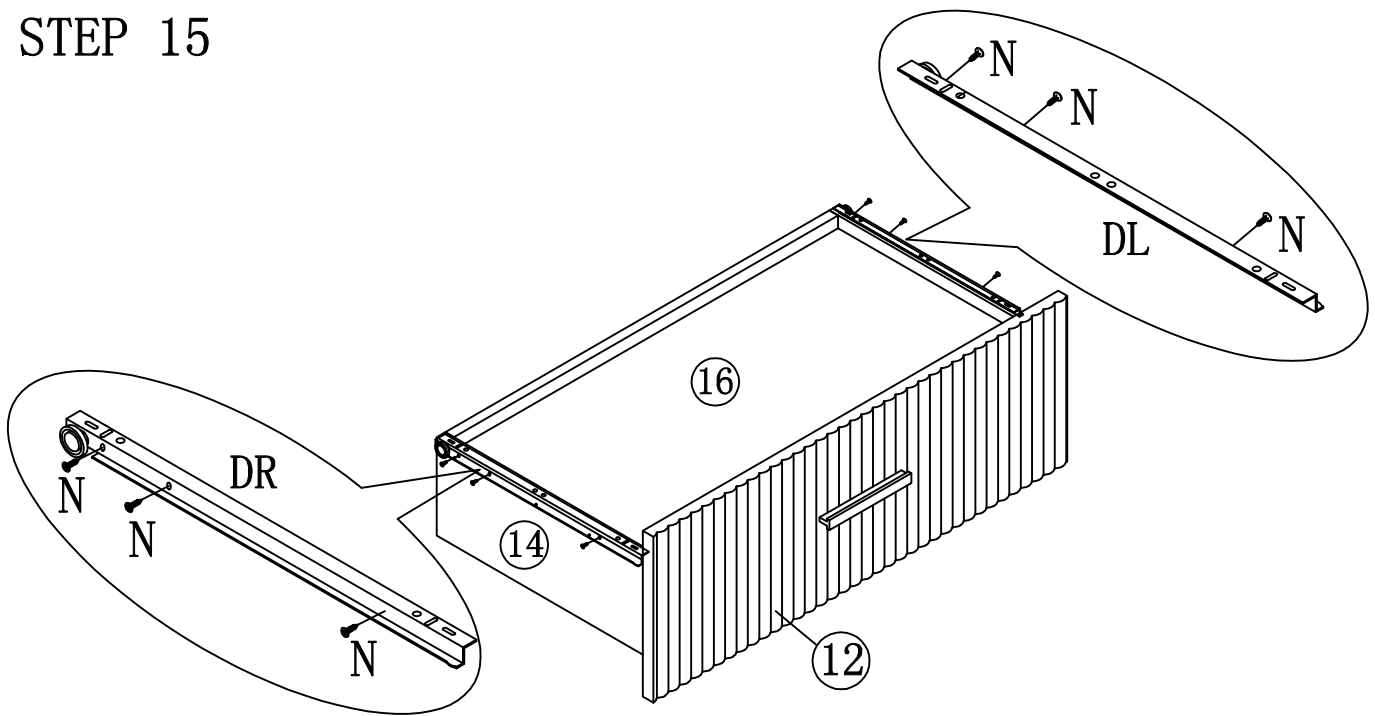
STEP 15



	DL * 1PC
	DR * 1PC
	N * 6PCS

Lock the slides on to the plate according to the holes shown in the illustration.

STEP 16

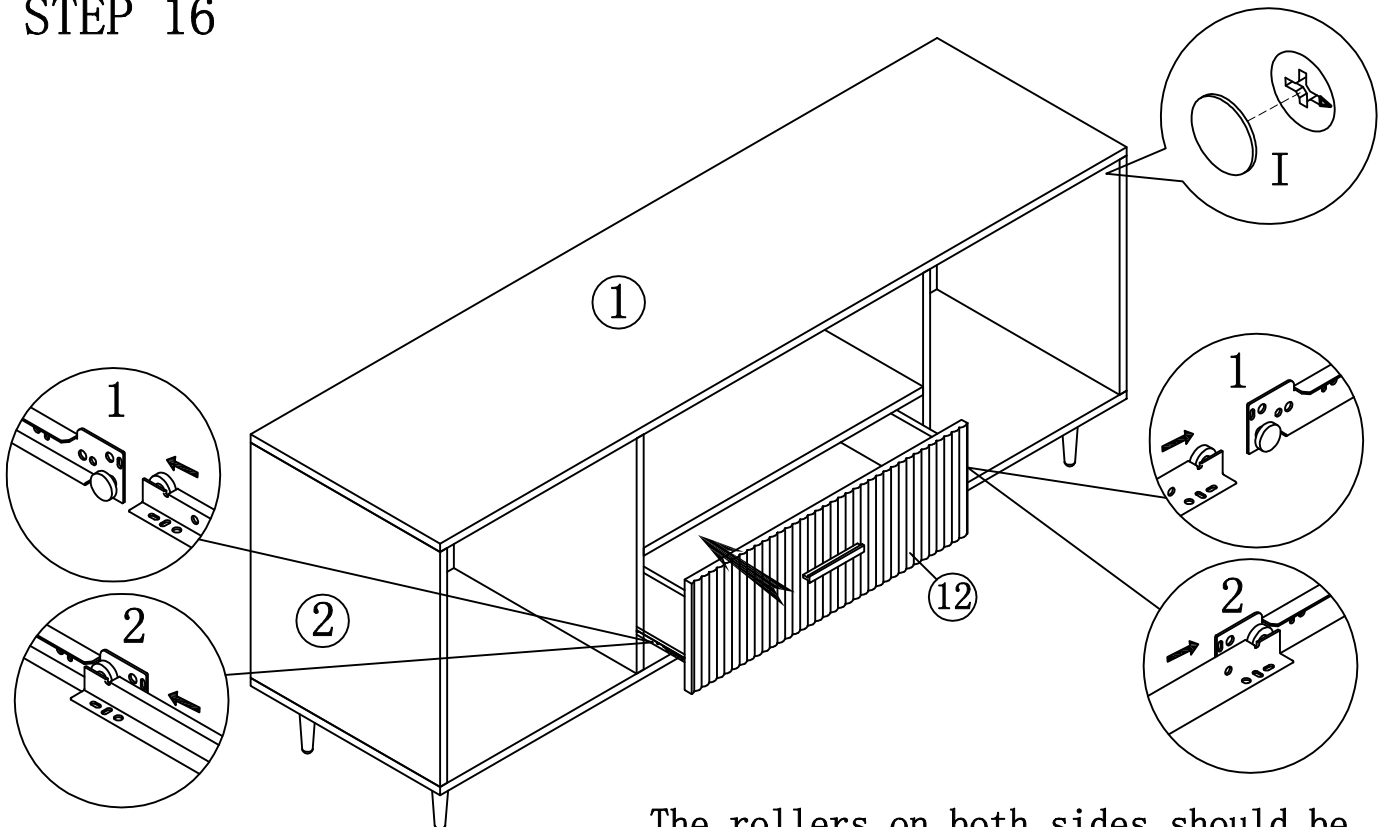





	I * 16PCS
---	-----------

The rollers on both sides should be fully seated in the slides as shown.

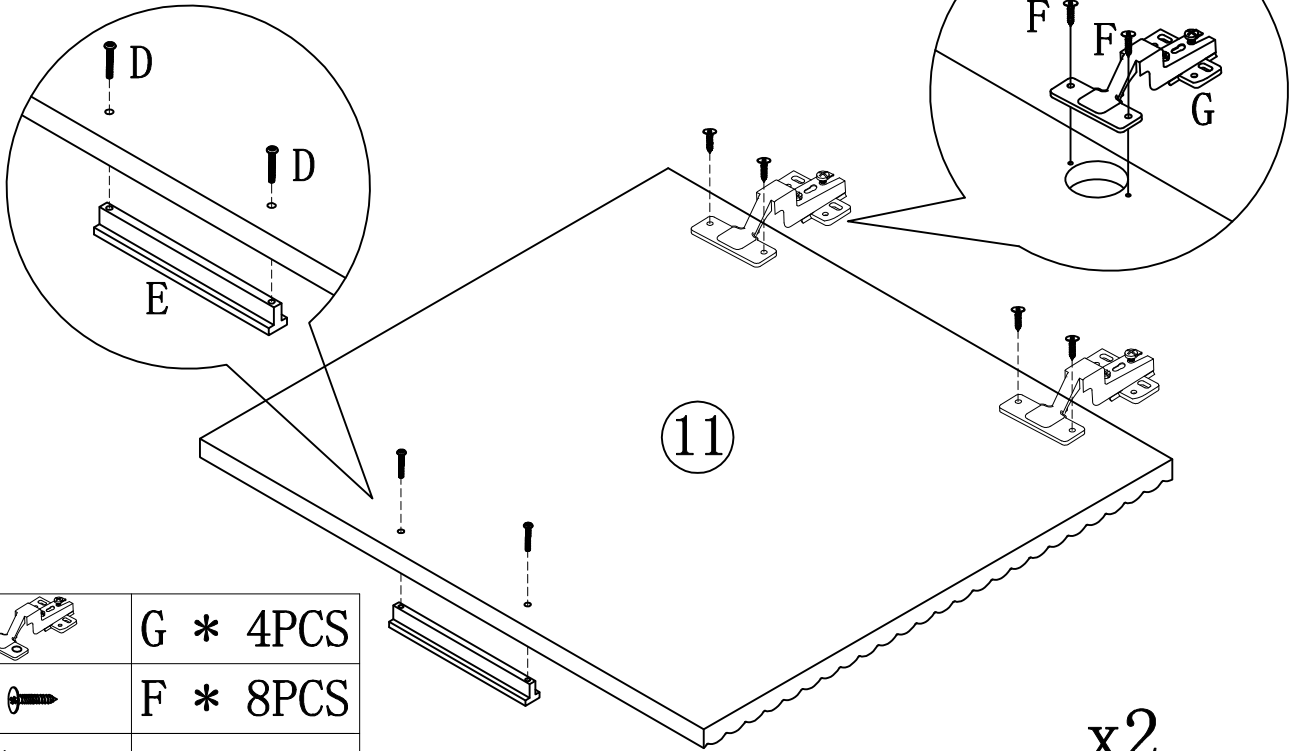
Assembly (EN) / Montageschritte (DE)

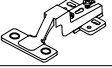
STEP 17



	G * 4PCS
	F * 8PCS
	D * 4PCS
	E * 2PCS

x2

STEP 18

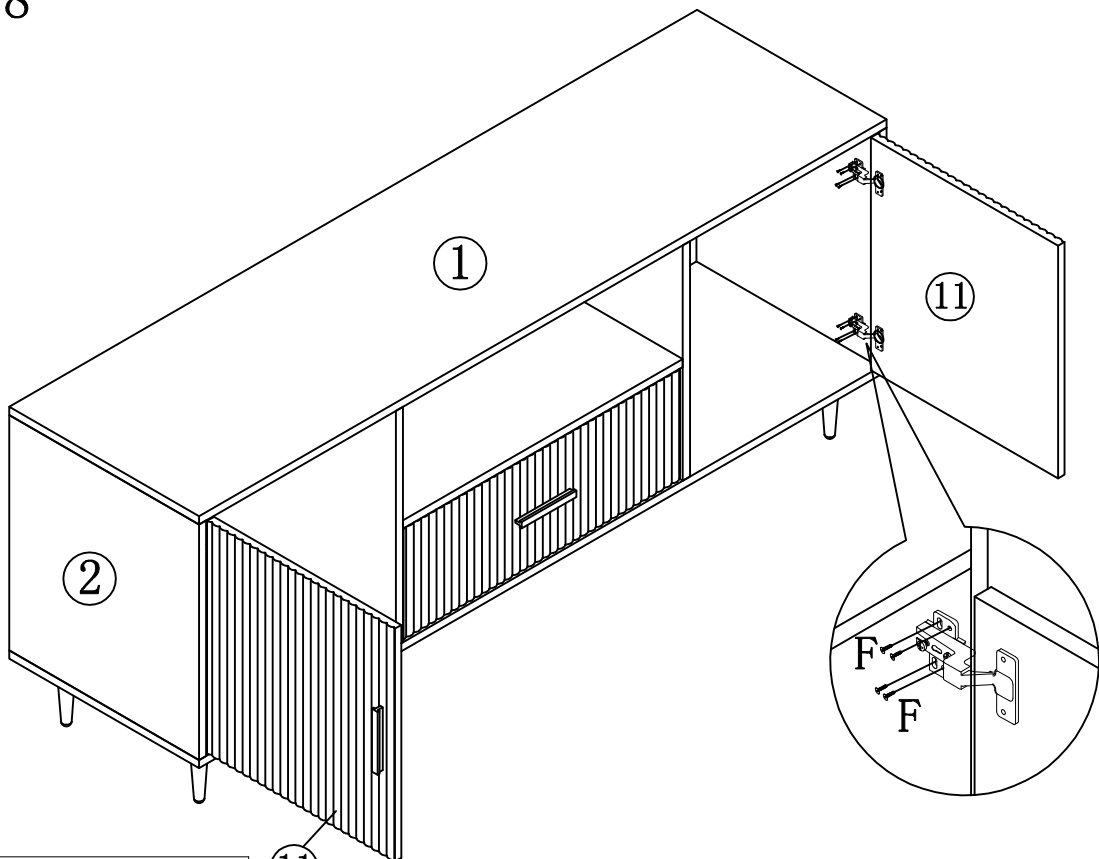

	F * 16PCS
---	-----------

Assembly (EN) / Montageschritte (DE)



NOTE : If you notice that the cabinet doors are not properly aligned, such as significant gaps or vertical or horizontal misalignment, please adhere to the following adjustment instructions.

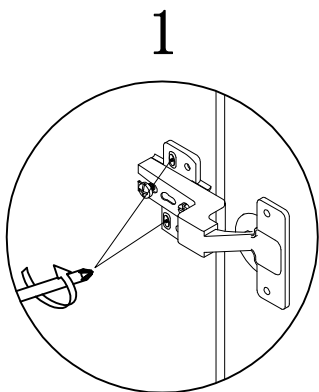
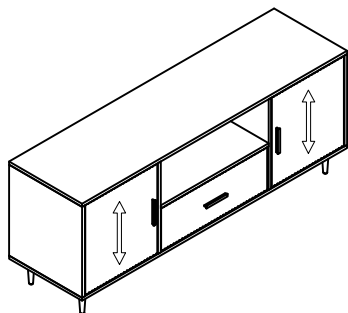

lose these 2 screws

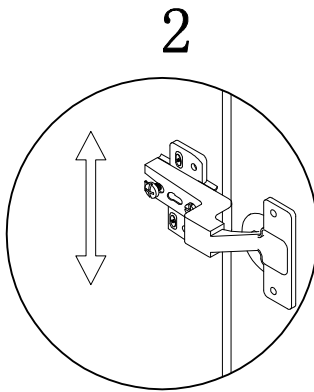

move hinge up/down

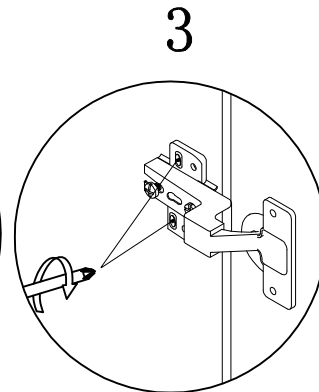

tighten these 2 screws again

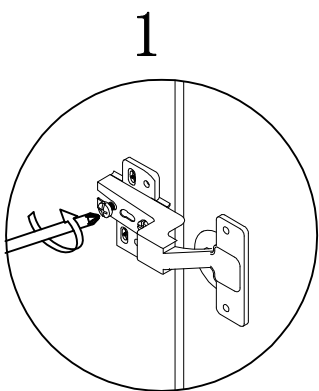
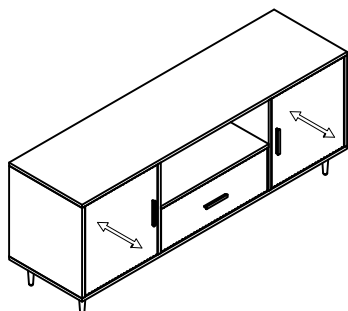

lose this screw

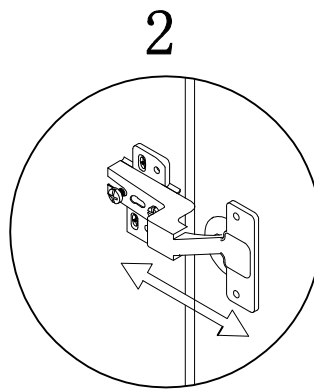

shift hinge in/out

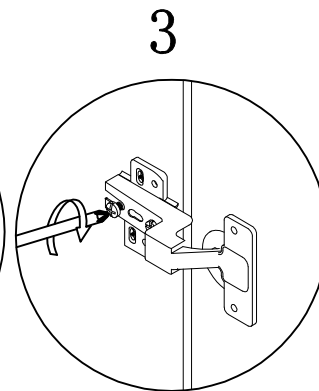

tighten this screw again

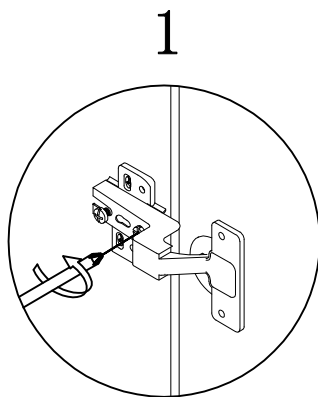
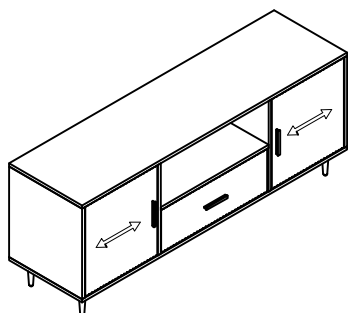

lose this screw would get hinge/door closer to side board

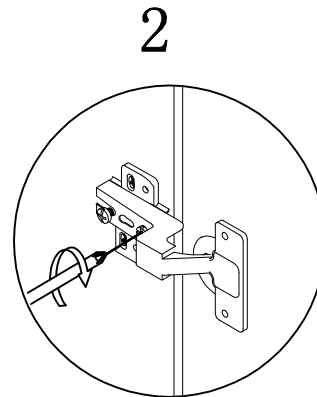

tighten this screw would get hinge/door away from side board

STEP 19

