

Vertical Angle Grab Bar (Left Hand)

- Material: 304 stainless steel
- Available Finishes: Satin Stainless (SA)
 Satin Peened (PN)
 Oil Rubbed Bronze (OB)
 Matte Black (MB)
 Powder White (PW)
- Dimensions:
 - Length (flange center, angle, to center): see table
 - Tube outside diameter: 1.25"
 - Tube walls: 18 gauge (1.2 mm)
- Flange cover: 14 gauge cover rotates into locked position to conceal flange mount plate and screws
- ADA Compliant

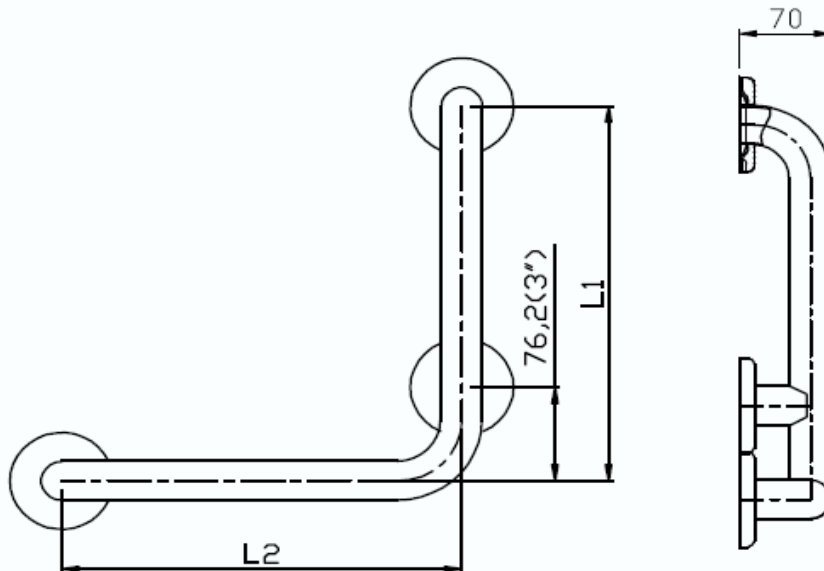
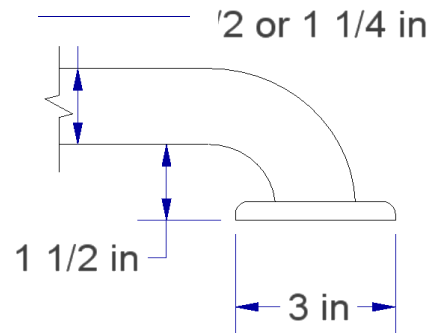

	L1	L2	Product Numbers
12x12	12"	12"	BAR-VL12-TW-125-XX
16x16	16"	16"	BAR-VL16-TW-125-XX
18x18	18"	18"	BAR-VL18-TW-125-XX
30x30	30"	30"	BAR-VL30-TW-125-XX
32x32	32"	32"	BAR-VL32-TW-125-XX
16x32	32"	16"	BAR-VL1632-TW-125-XX

IMPORTANT INSTRUCTIONS

SAFETY NOTE: Concealed In-Wall support backing is ALWAYS REQUIRED for this product (not included) – and must be supplied and selected by a licensed installer/contractor to meet both weight bearing and local code requirements. PRODUCT INSTALLATION SHOULD BE DONE BY A LICENSED INSTALLER/CONTRACTOR.

CAUTION: Personal injury and/or property damage may result from improper wall support or mounting, which is not covered under warranty.

WARNING: Do NOT use this instruction sheet for grab bars with welded stud or internal threads.

IT IS ESSENTIAL TO MARK THE CENTERLINE DISTANCE BETWEEN THE TWO MOUNTING FLANGE PLATES ON EACH SIDE AS WELL AS THE DISTANCE FROM CENTER OF EACH MOUNTING PLATE TO THE FINISH FLOOR TO ASSURE PROPER ALIGNMENT.

Installation Notes:

1. Bar as Selected
2. Flange Cover Plate
3. Flange
4. Stud
5. Drywall
6. Tile (if applicable)
7. 1/4" (6mm) Diameter Pilot Hole –**TILE PROJECTS ONLY**
8. 1/8" (3mm) Diameter Pilot Hole into Stud
9. 10/24" x 2" Threaded Stainless Steel Hanger Bolt
10. Threaded Stainless Steel Bolt Nut
11. 2" Self-tapping screw

Installation Steps:

1. Locate wall stud or previously installed backer board.
2. Use the flange as a template to mark the mounting hole locations. (We recommend using a level to achieve perfect horizontal or vertical mounting.)
3. Drill 1/8" (3mm) diameter pilot hole into stud for each flange.
 - a. If wall is tiled, drill through the tile with a 1/4" (6mm) diameter masonry drill bit.
4. Drive hanger bolts for center post directly into stud using hanger bolt driver leaving 1/4" of thread exposed. (NOTE: Hanger bolts for center post MUST be installed before the end posts are fastened to the wall.)
5. Place Flange over exposed hanger bolts.
6. Screw bolt nut onto hanger bolts until secure.
7. Using the 2" self-tapping screws, fasten each end post to the wall.
8. After all flanges are secured, apply bead of clear sealant around bottom rim of flange cover