



IMPORTANT INFORMATION

READ CAREFULLY.

KEEP THIS INFORMATION FOR FURTHER REFERENCE.

GENERAL GUIDELINES

- Please read the following instruction carefully and use the product accordingly.
- Please keep this manual and hand it over when you transfer the product.
- This summary may not include every detail of all variations and considered steps. Please contact us when further information and help are needed.

NOTES

- Please follow the assembly instructions precisely and only use the product as intended.
- If an odor is present when first opening the package, please leave the unwrapped product in a shaded and ventilated area for a few days to air out.
- Prior to assembly, please check the product for defects or missing accessories. If any defects are found or accessories are missing, do not use product as damage or injury may occur;
- During assembly, please only slightly tighten all screws in their correct position first, then fully tighten them. A Philips screwdriver is recommended but not included.
- It is suggested you regularly check the products bolts and connections to ensure safe use.
- Assemble the item on a soft flat and clean surface to avoid scratches and damage.
- It is recommended that two people assemble this product.

WARNINGS

- During assembly, keep parts and packaging materials away from children and pets as there could cause injury and are a potential choking hazard.
- Avoid sharp objects or corrosive chemicals to prevent damage to the product.
- Please open the item slowly and cautiously to avoid pinching your hands by metal joints, especially children.

ANTI-TIP WARNING

- Serious or fatal crushing injuries can occur from furniture tip-over. To prevent this furniture from tipping over it must be permanently fixed to the wall.
- Since different wall materials require different types of fixing device, for advice on suitable fixing systems, contact your local specialized dealer.

Tools Needed (not included)



Prepare Tools
Instead of
Coming Empty
Handed

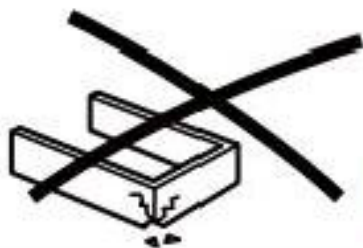

Handle Gently

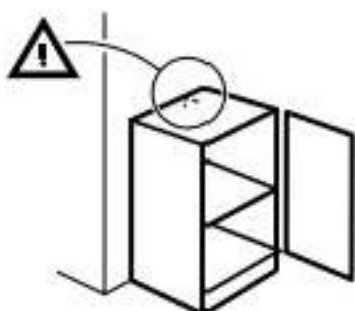

Gently Push
Against the
Wall and Do
Not Tip Over

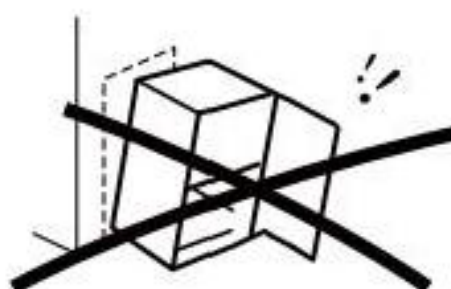

Tips:

- If you have any further questions,
- Before installation, please make sure you have all the hardware, the serial numbers are properly labeled corresponding to the list, and the quantity is correct.
- Enjoy your new purchase!

**Slides Must Be Separated Before Assembly,
After Separated,Set Aside Until Needed for Assembly.**

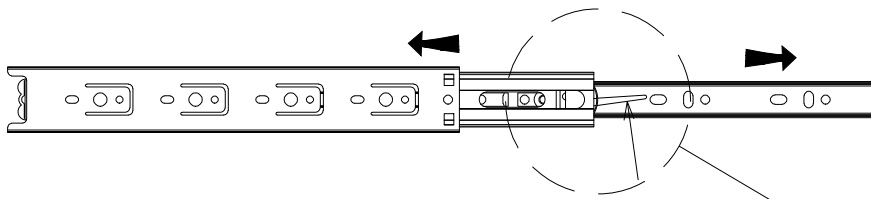

STEP1: Extend slide

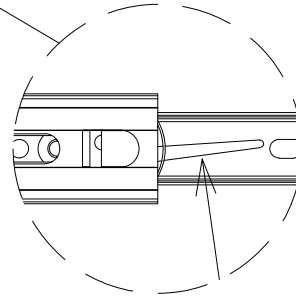
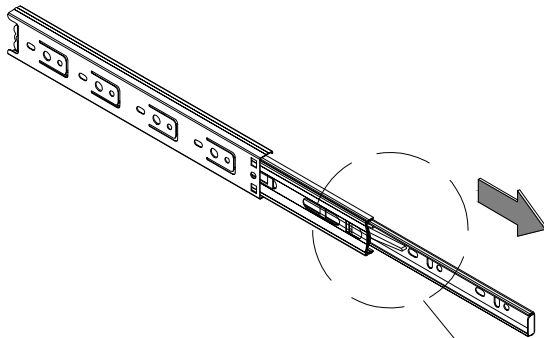

STEP3: Remove Runner

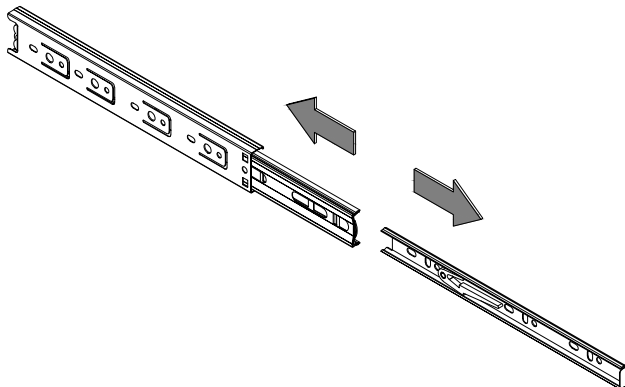

STEP2: Push Lever UP

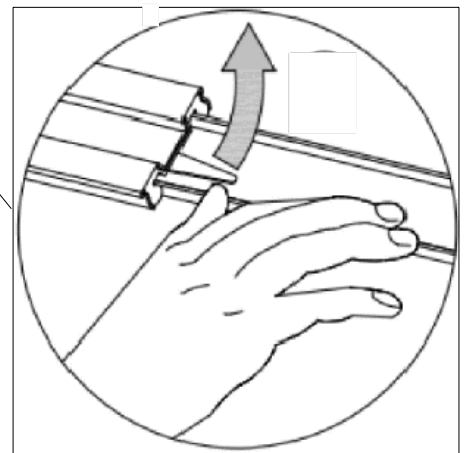





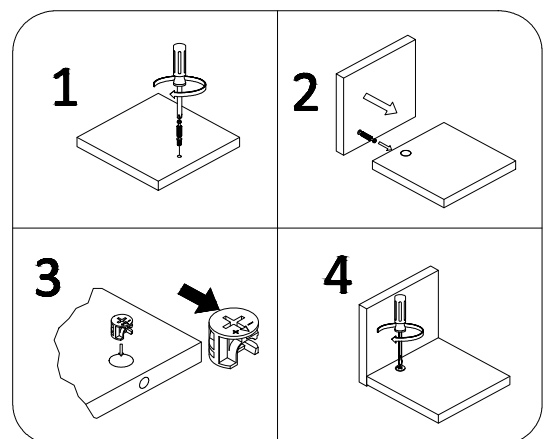
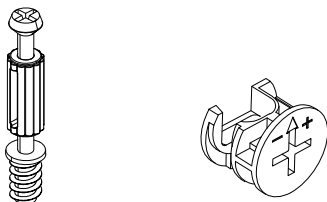

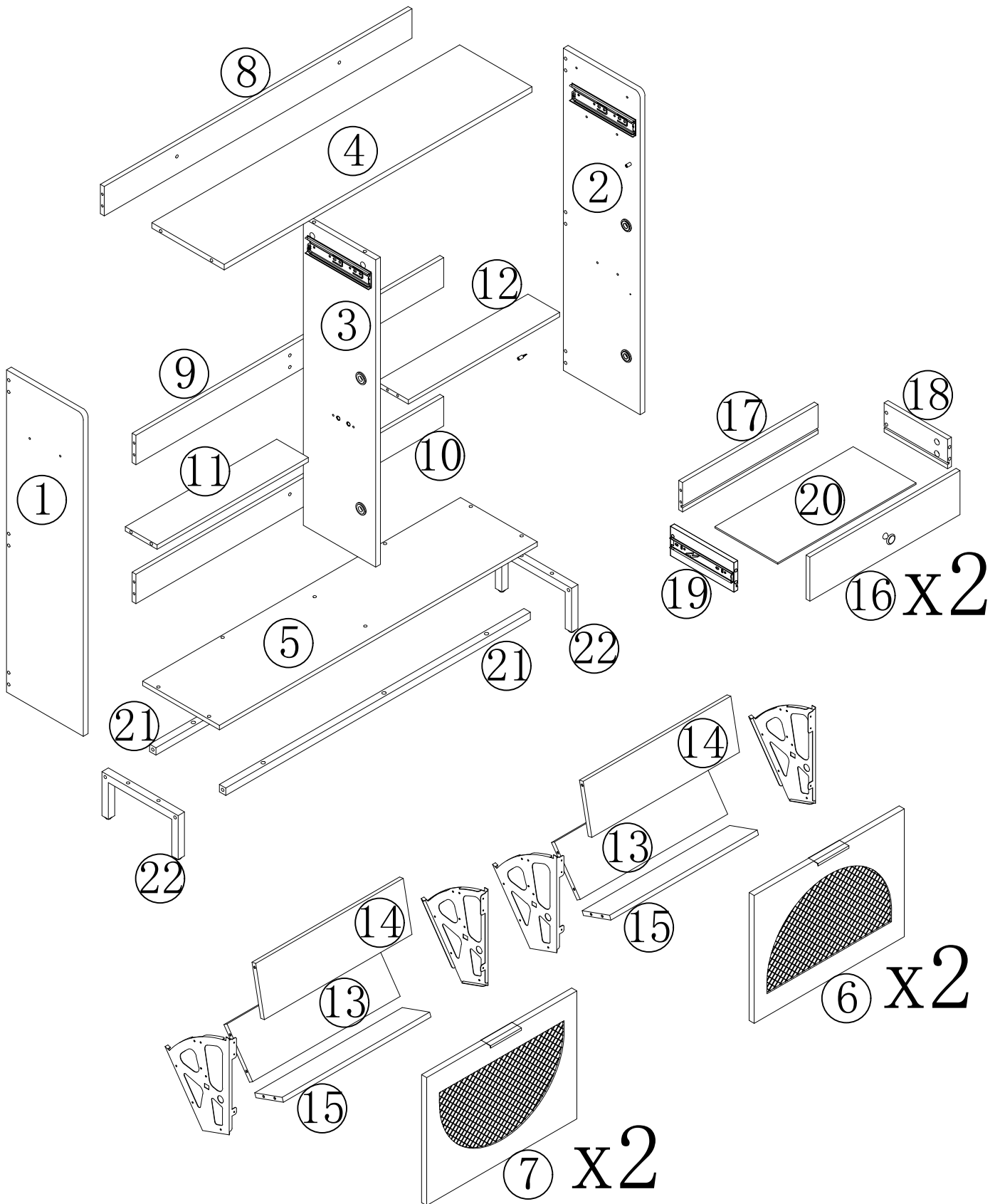

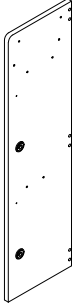
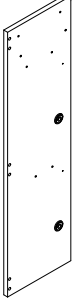
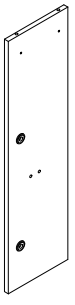
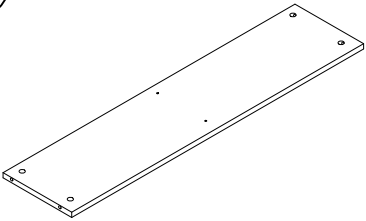
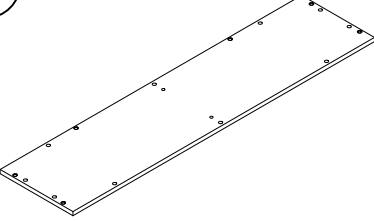
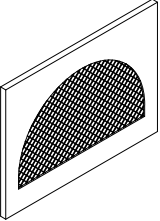
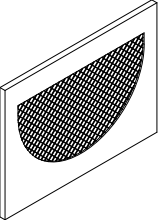
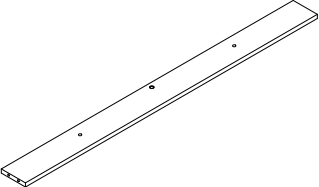
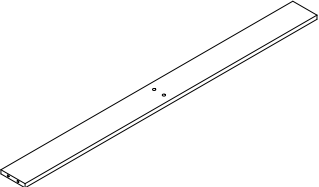
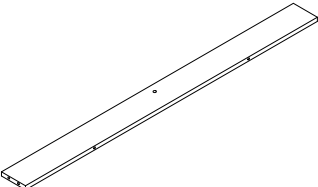
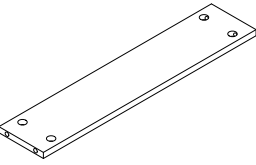
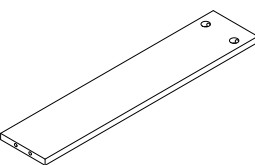
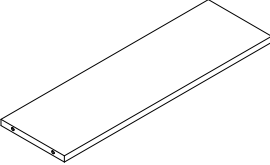
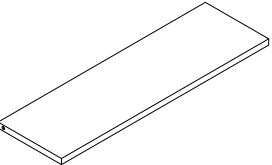
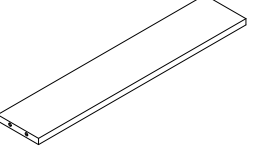
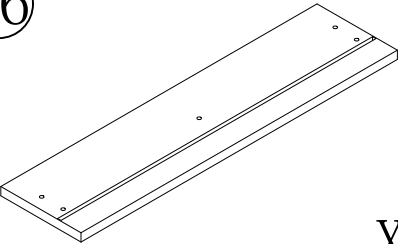
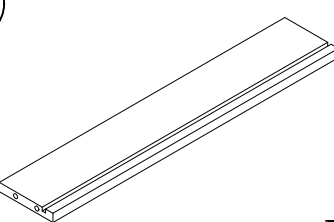
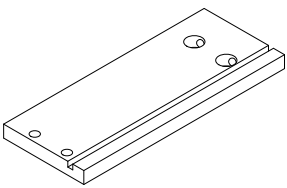

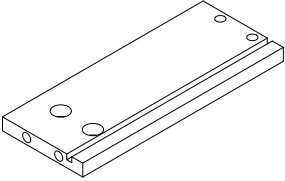
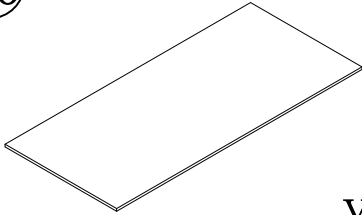
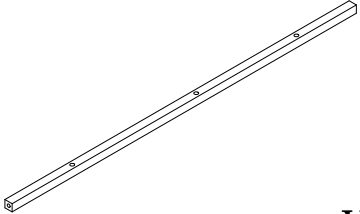
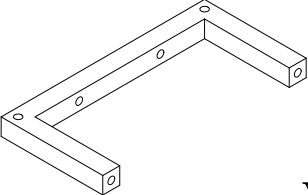
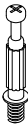

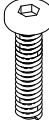
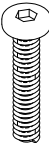
CAM LOCK FASTENING SYSTEM

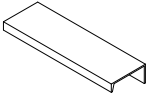
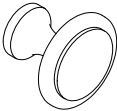
This Cam Lock Fastening System will be used throughout the assembly process

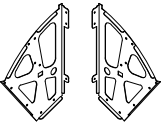

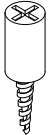
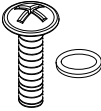
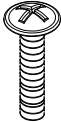
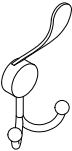



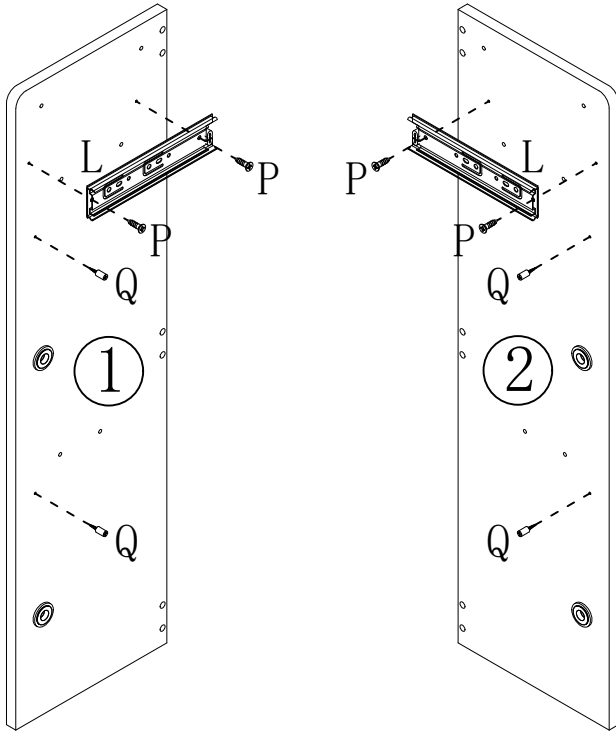

① 	② 	③ 
④ 	⑤ 	⑥  X2
⑦  X2	⑧ 	⑨ 
⑩ 	⑪ 	⑫ 
⑬  X4	⑭  X4	⑮  X4
⑯  X2	⑰  X2	⑱  X2

<p>19</p>  <p>X2</p>	<p>20</p>  <p>X2</p>	<p>21</p>  <p>X2</p>		
<p>22</p>  <p>X2</p>				
<p>A</p>  <p>20 PCS</p>	<p>B M7*50</p>  <p>35 PCS</p>	<p>C</p>  <p>20 PCS</p>	<p>E M6X25</p>  <p>10 PCS</p>	<p>H M6X40</p>  <p>4 PCS</p>
<p>I</p>  <p>8 PCS</p>	<p>J</p>  <p>4 PCS</p>	<p>K</p>  <p>2 PCS</p>	<p>L 200-8"</p>  <p>4 PCS</p>	<p>O</p>  <p>4 PCS</p>
<p>P M3.5x12</p>  <p>88 PCS</p>	<p>Q M7x25</p>  <p>4 PCS</p>	<p>S M4X16</p>  <p>2 PCS</p>	<p>T M4*18</p>  <p>2 PCS</p>	<p>X</p>  <p>2 PCS</p>
<p>Y M8</p>  <p>4 PCS</p>	<p>Z 18MM</p>  <p>1 PCS</p>			

1



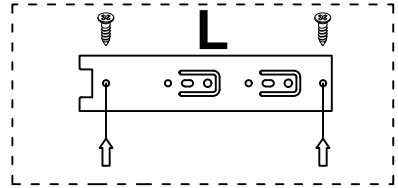

Q M7x25  4 PCS	L 200-8"  2 PCS	P M3.5x12  4 PCS
---	--	---

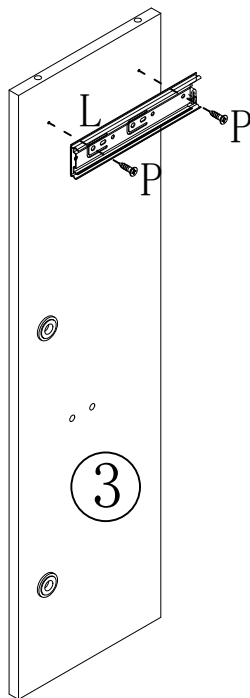

2



L 200-8"  1 PCS	P M3.5x12  2 PCS
--	---

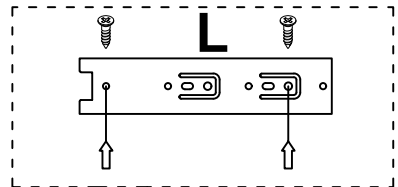

3

B M7*50



2 PCS

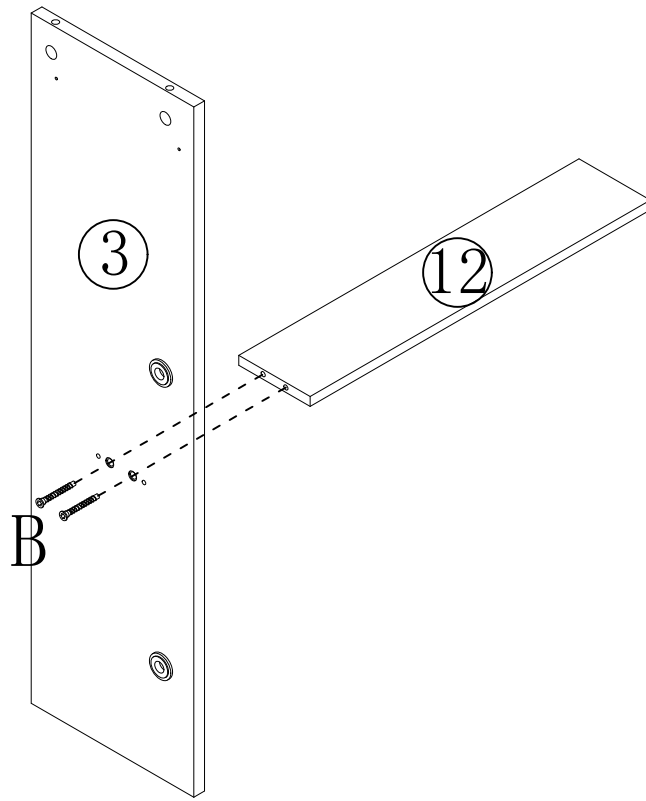

4

A



2 PCS

C



2 PCS

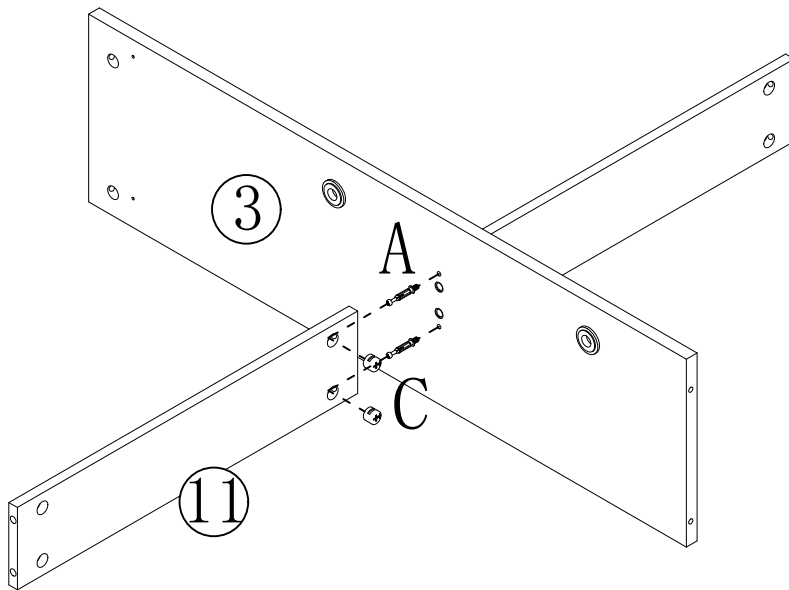

5

B M7*50



3 PCS

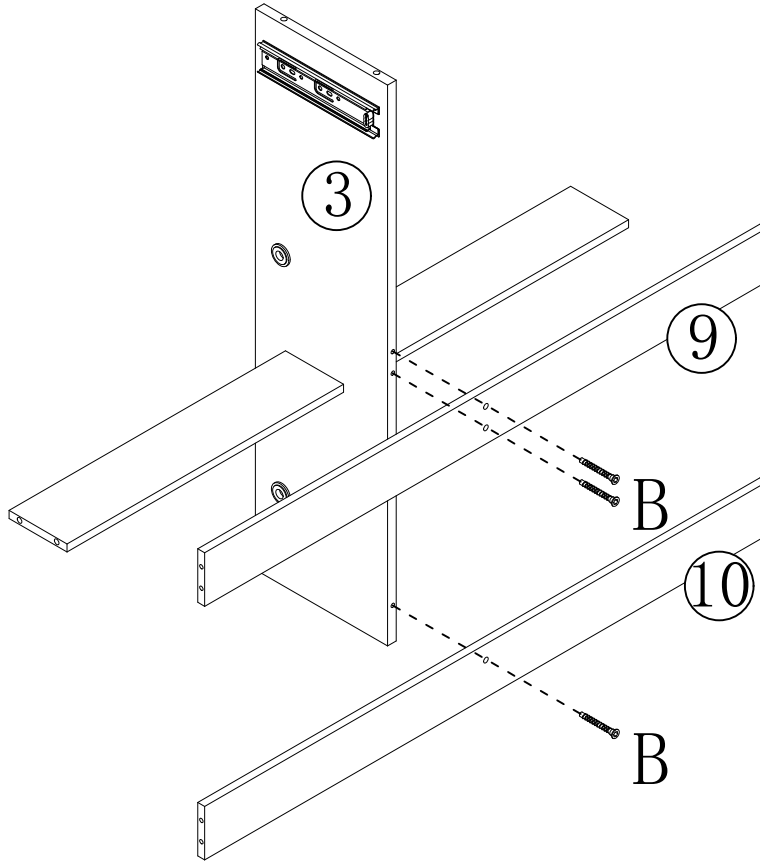

6

B M7*50



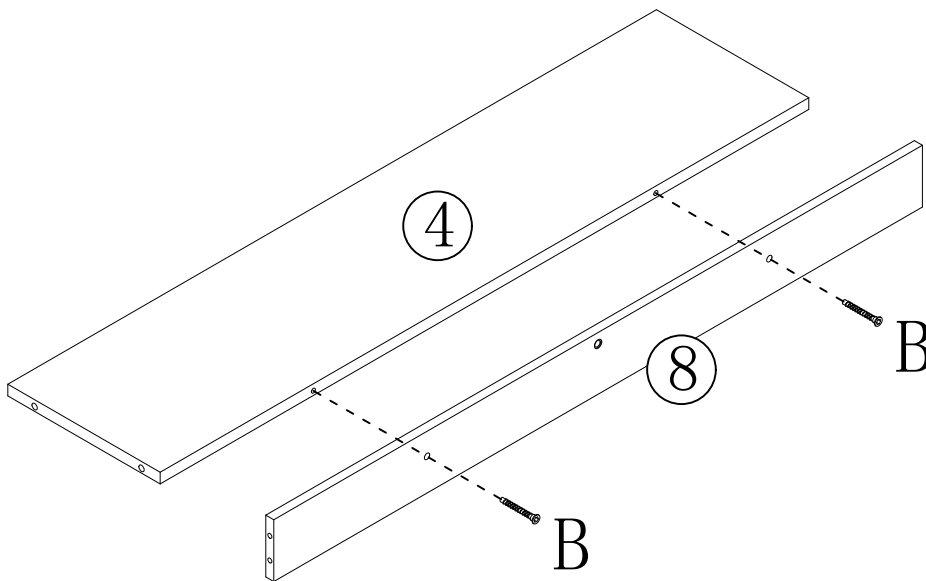

2 PCS



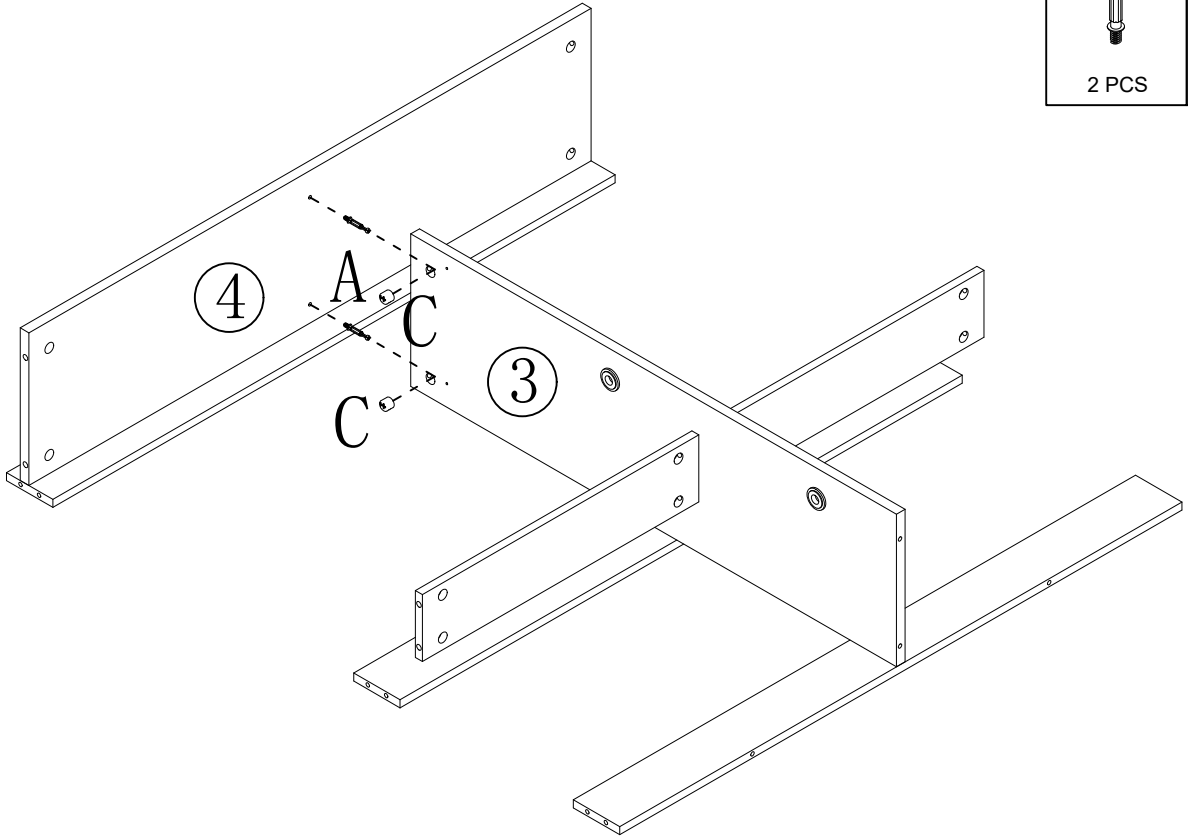

7



A	C
	
2 PCS	2 PCS

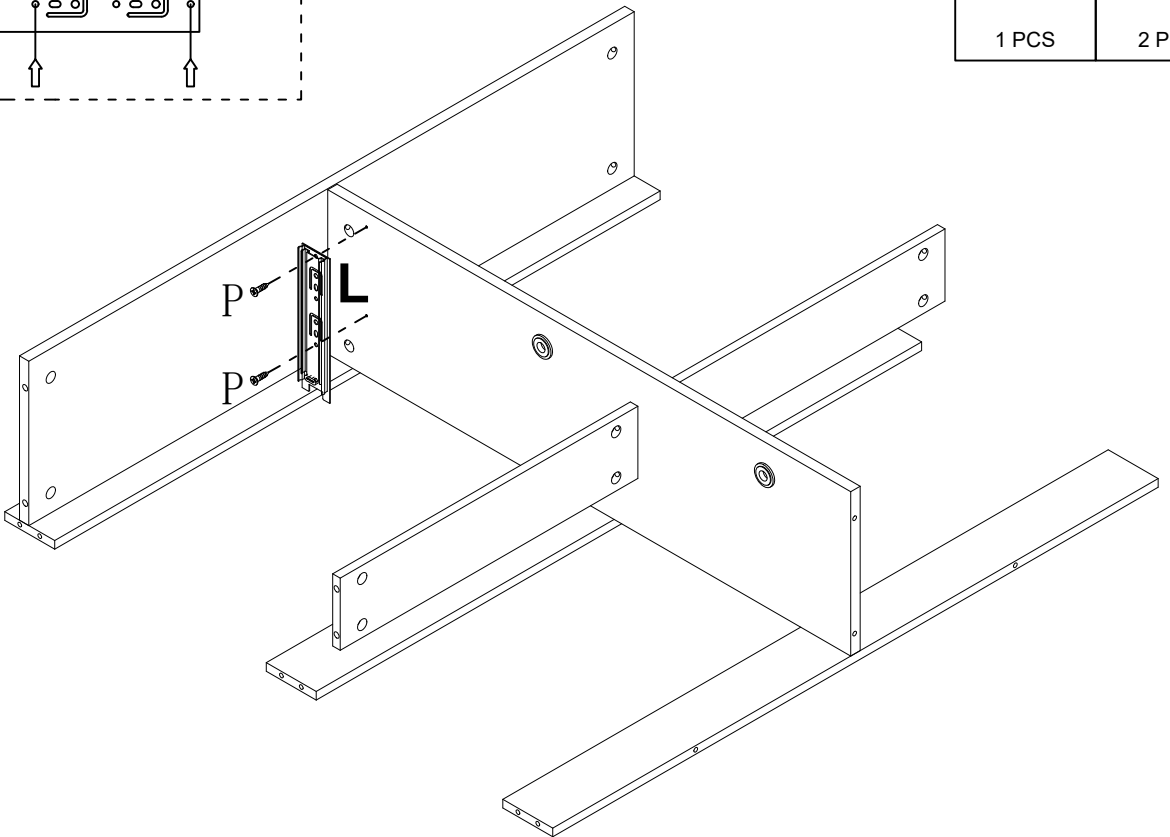
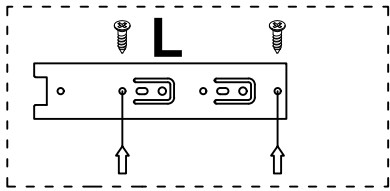

8

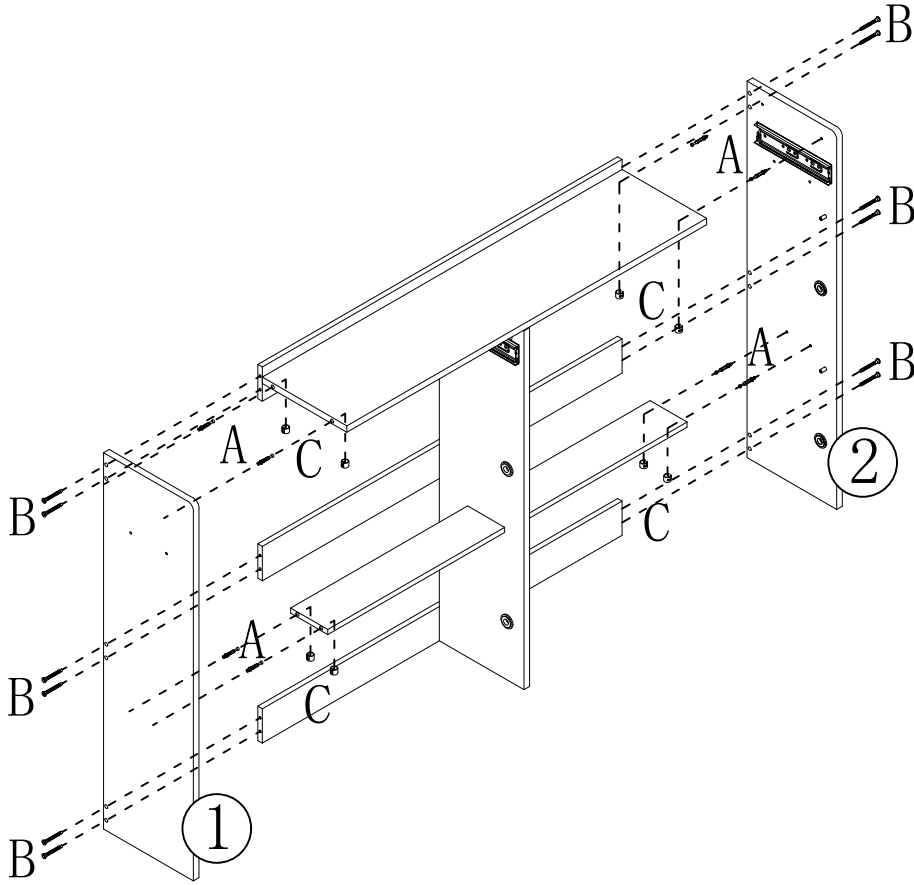

L 200-8"	P M3.5x12
	
1 PCS	2 PCS

9



A	C	B M7*50
		
8 PCS	8 PCS	12 PCS

10

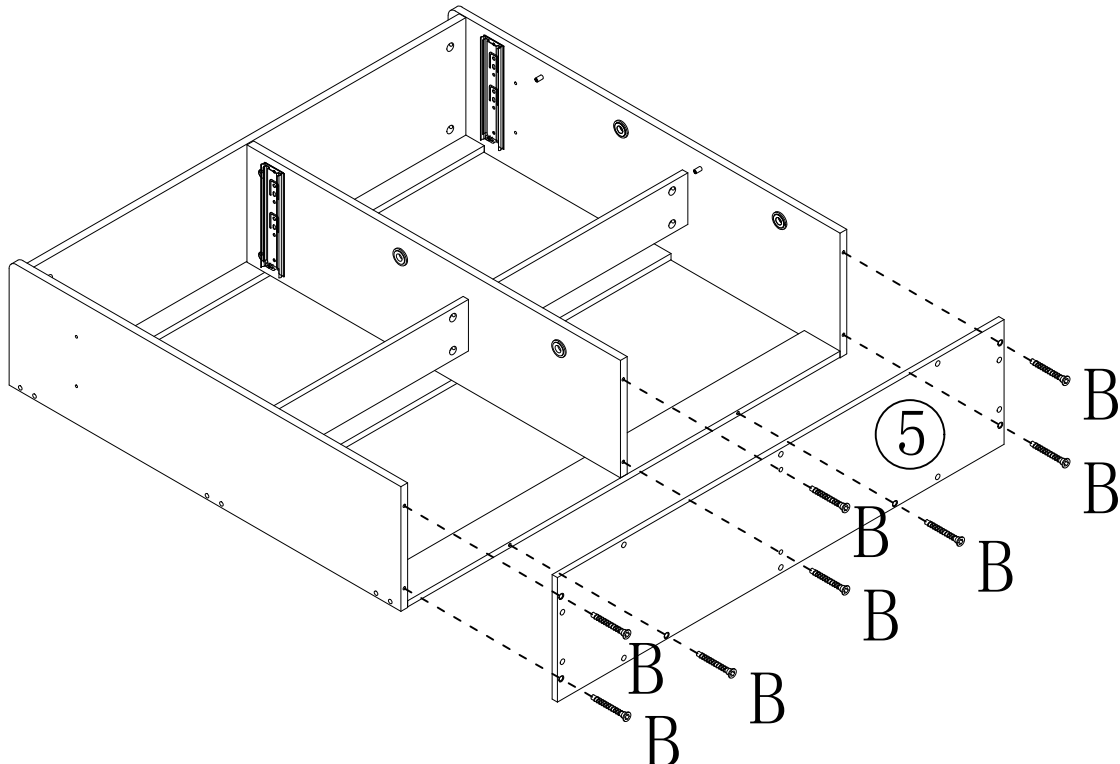

B M7*50

8 PCS

11

Y M8

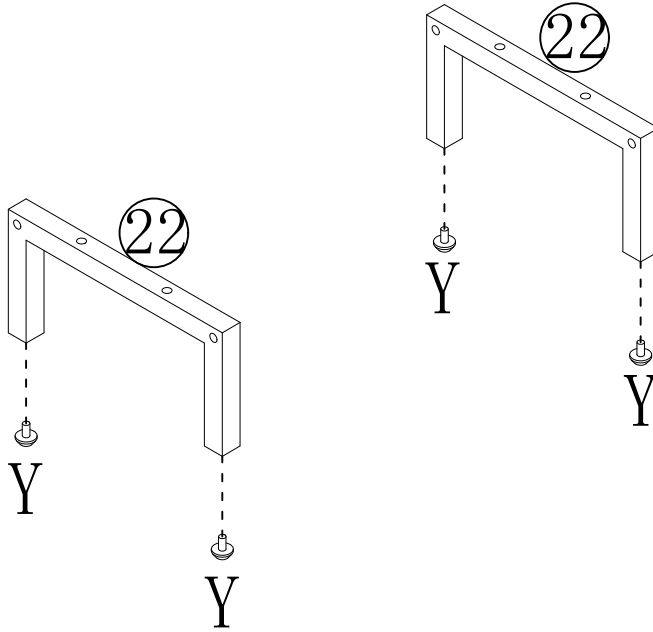

4 PCS



12

H M6*40



4 PCS

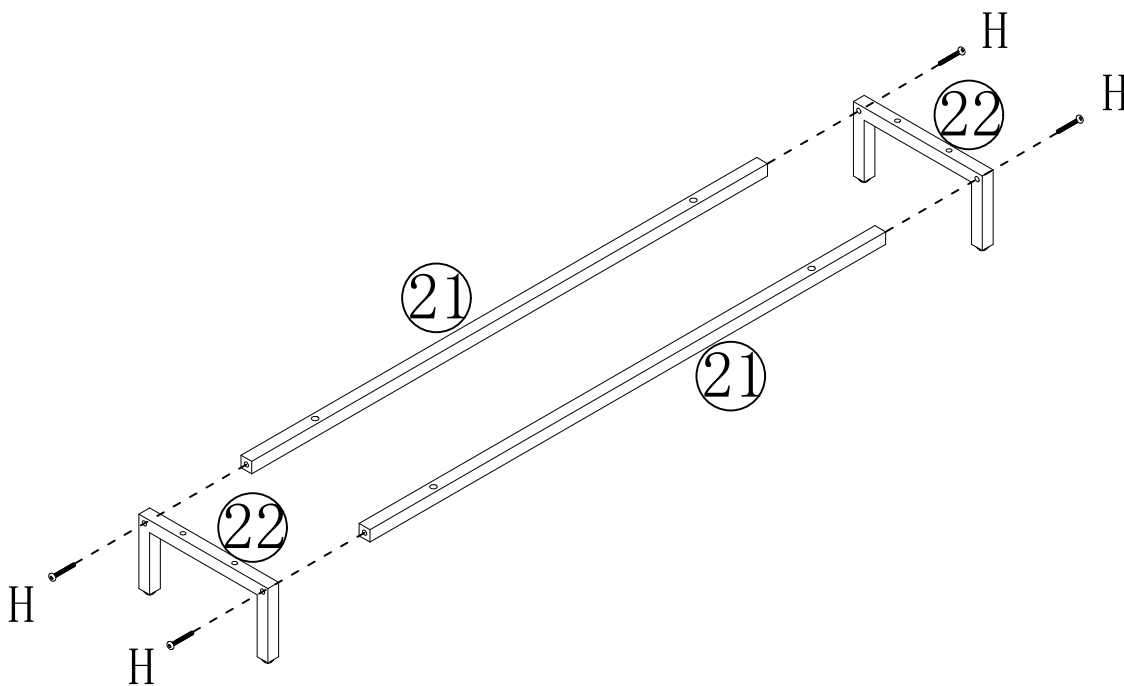

13

E M6*25



10 PCS

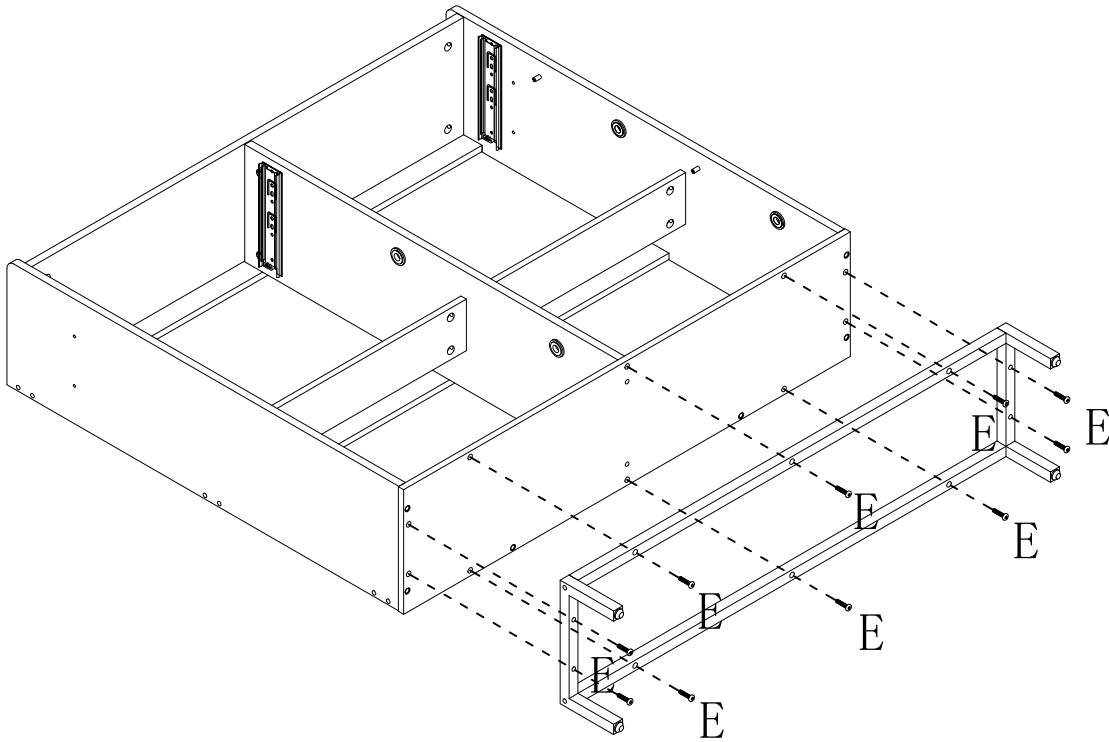

14

Hooks can be installed as per your requirements.

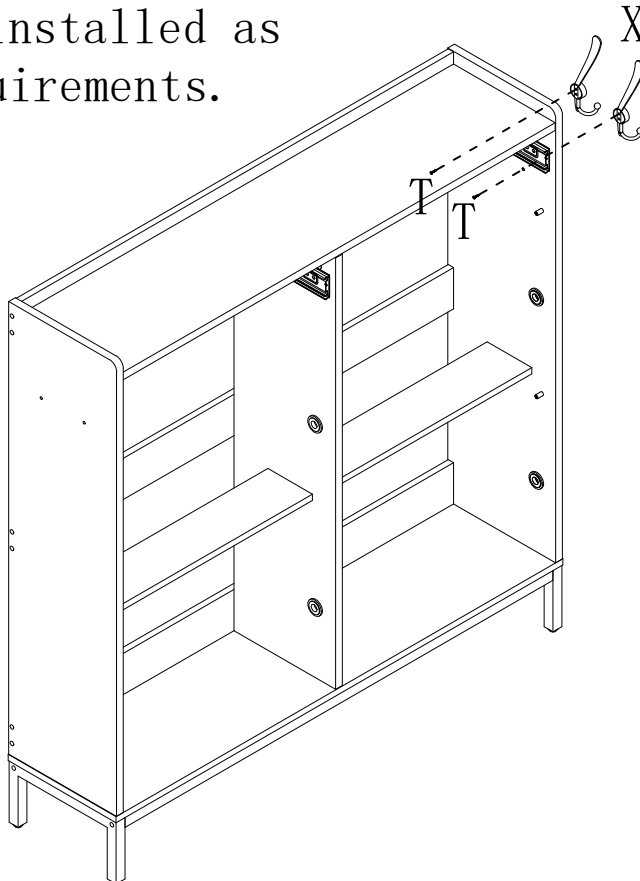

X









2 PCS

T M4*18



2 PCS

15

L 200-8"  4 PCS	P M3.5x12  8 PCS	K  2 PCS	S M4X16  2 PCS	B M7X50  8 PCS	A  8 PCS	C  8 PCS
--	---	---	---	---	---	---

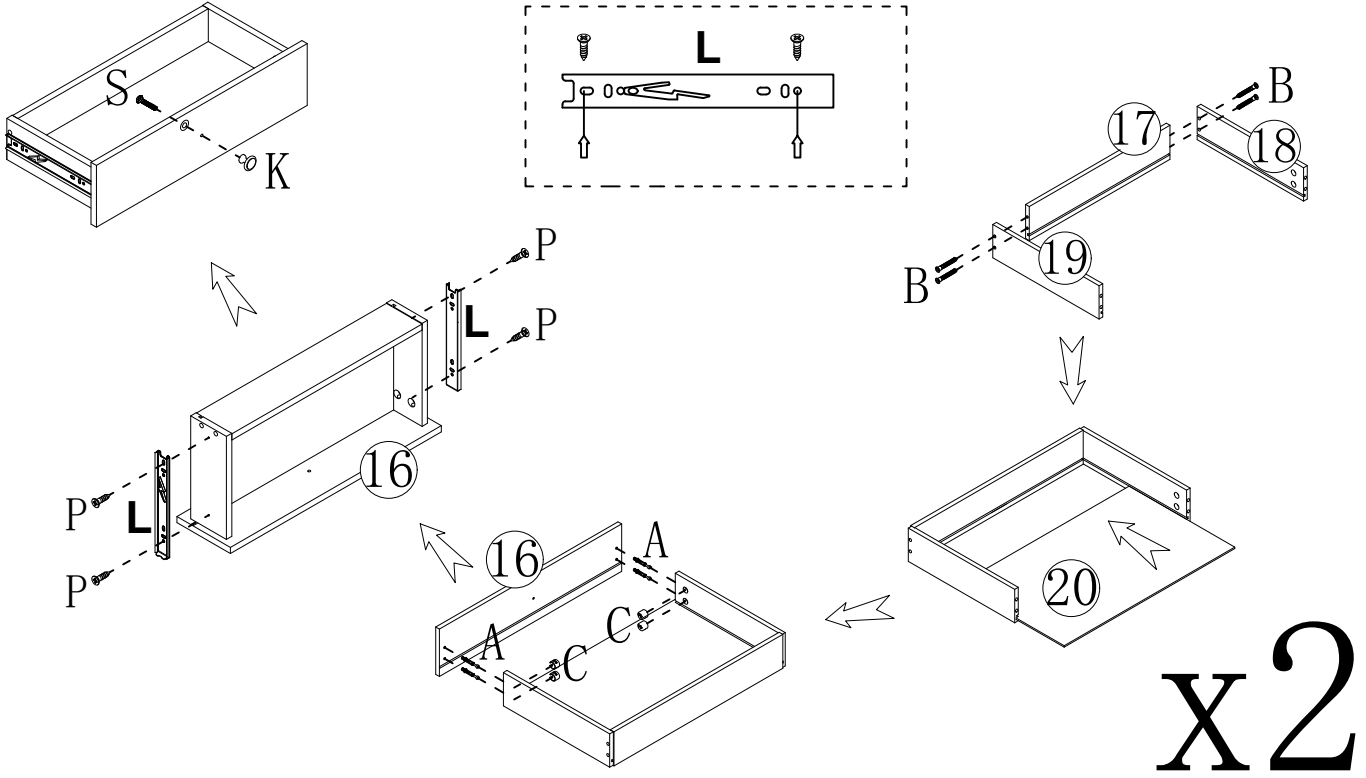

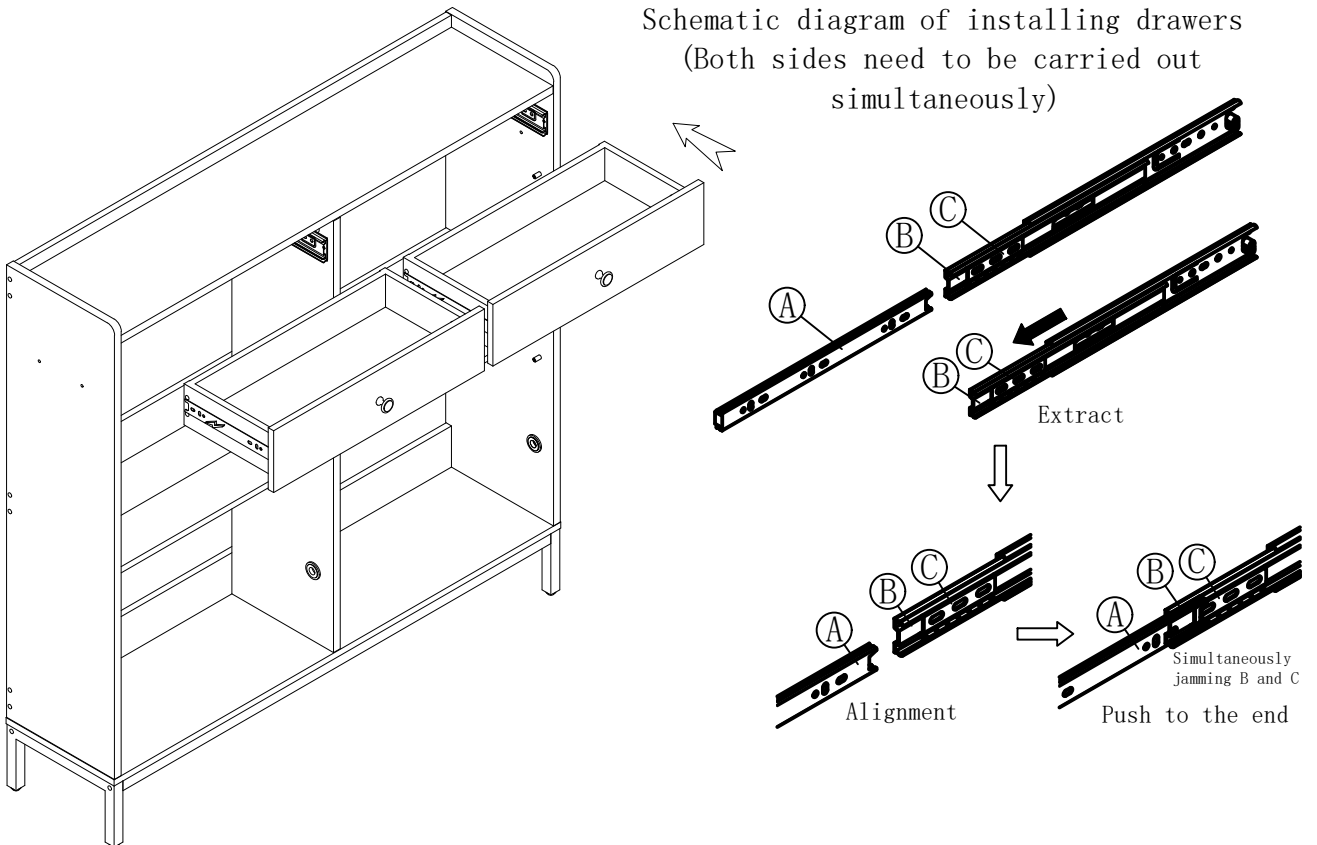

16

Schematic diagram of installing drawers
(Both sides need to be carried out simultaneously)

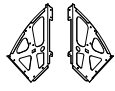

17

O	P M3.5x12
	
4 PCS	16 PCS

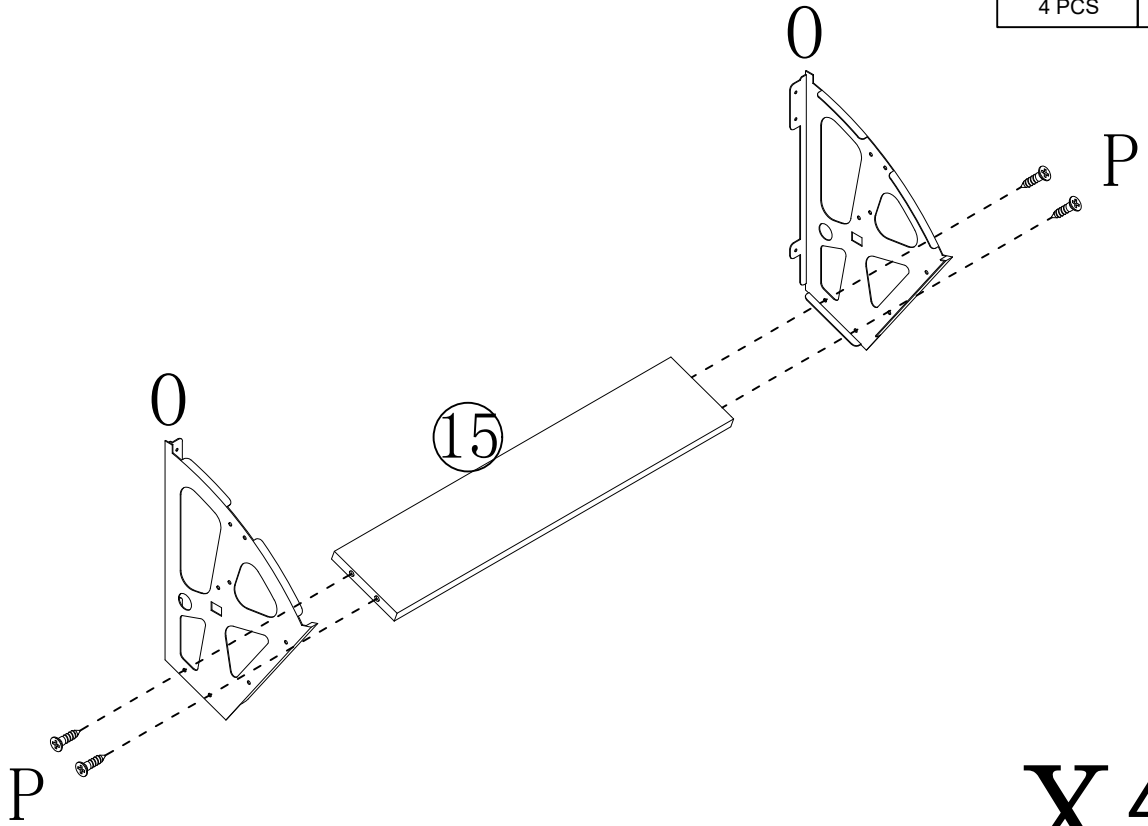

x4

18

P M3.5x12

12 PCS

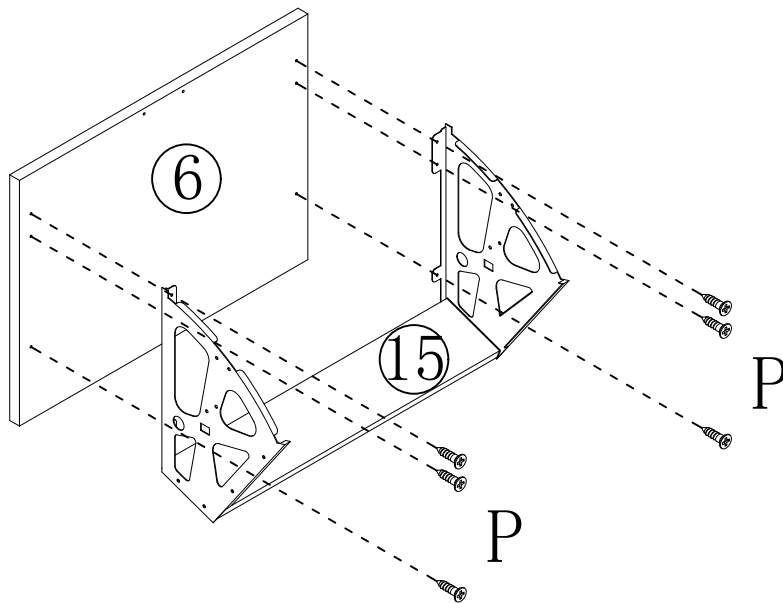

x2

19

P M3.5x12



12 PCS

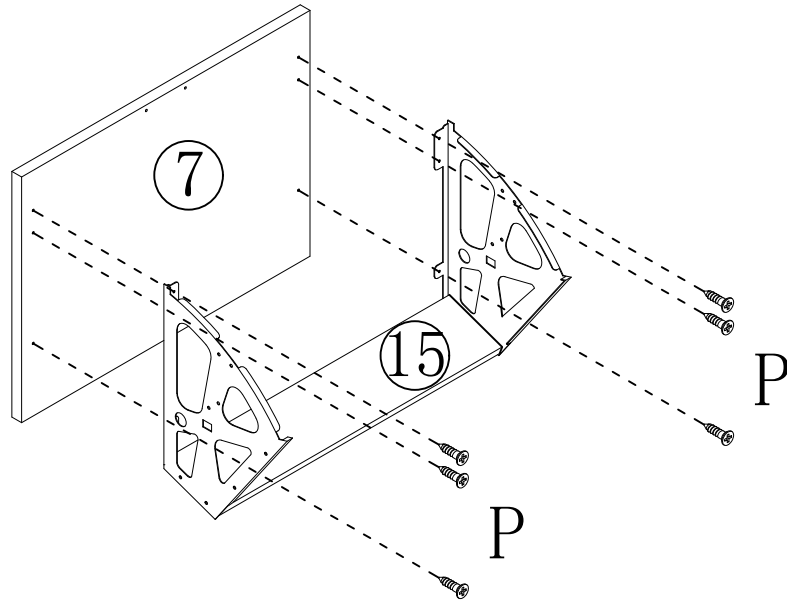

x2

20

J



2 PCS

P M3.5x12



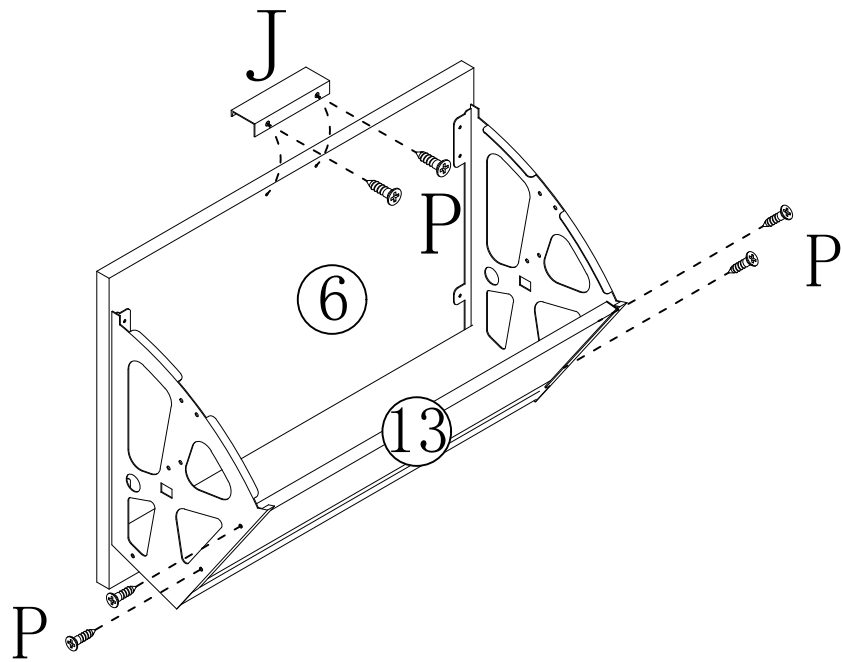

12 PCS



x2

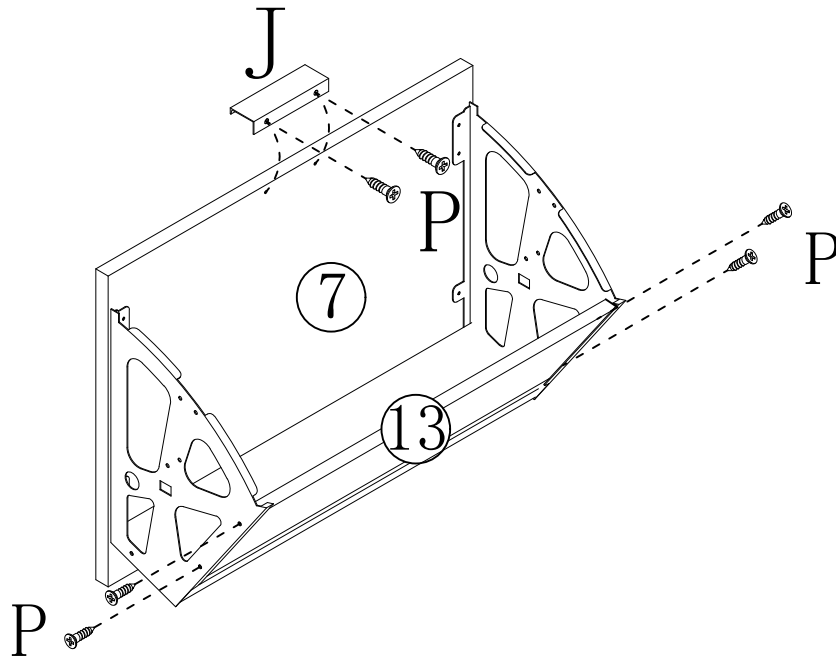

21

J	P M3.5x12
	
2 PCS	12 PCS



x2

22

I
 
8 PCS

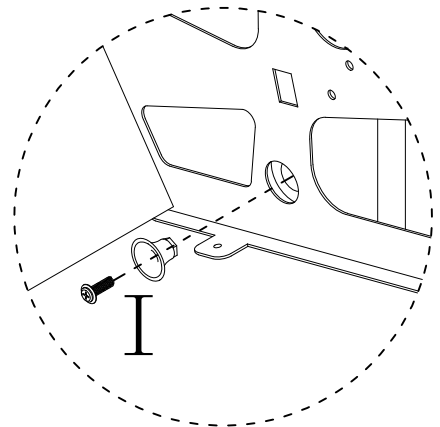
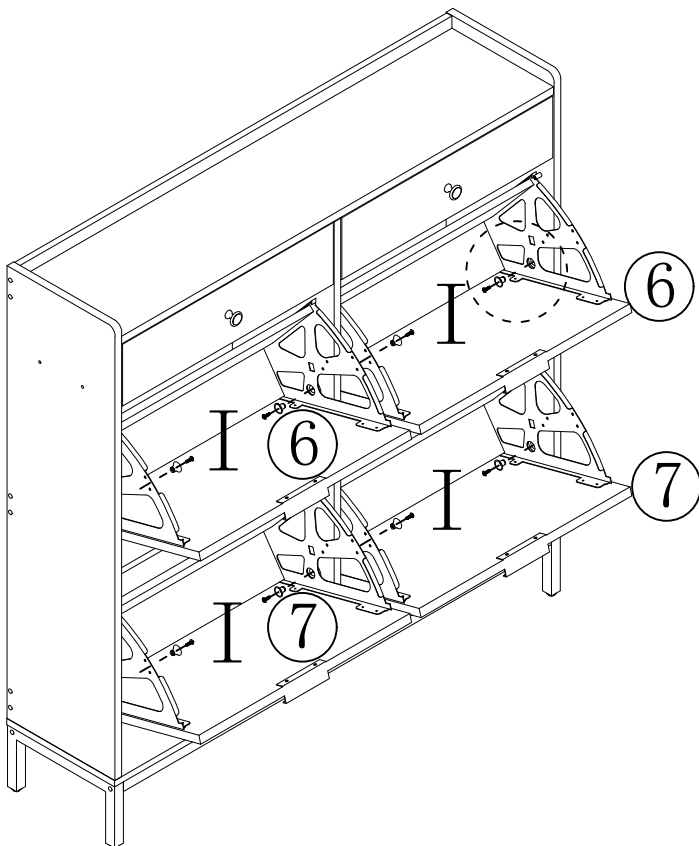

23

P M3.5x12
4 PCS

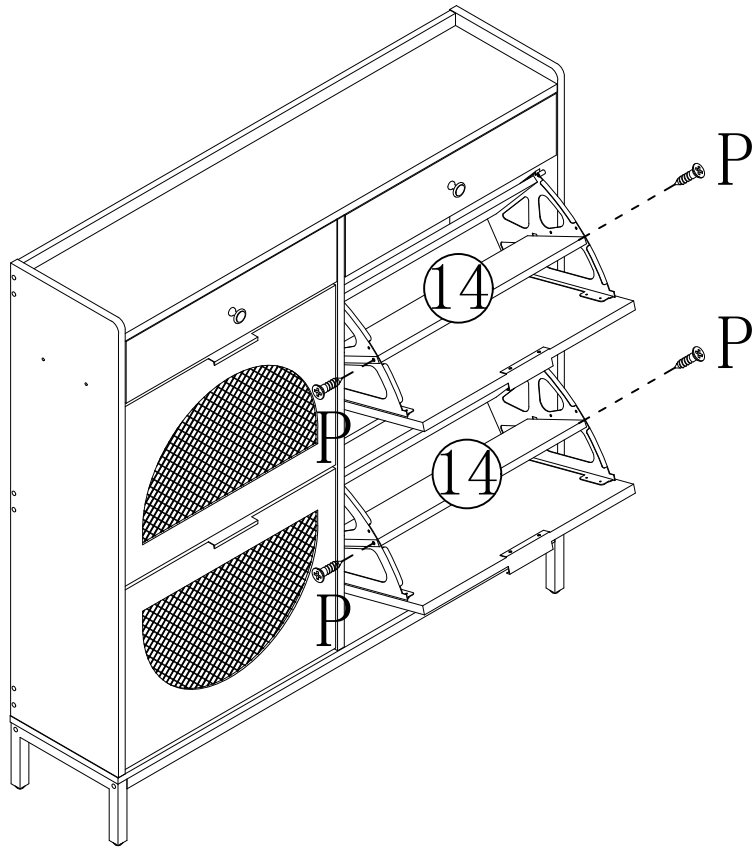

24

P M3.5x12
4 PCS

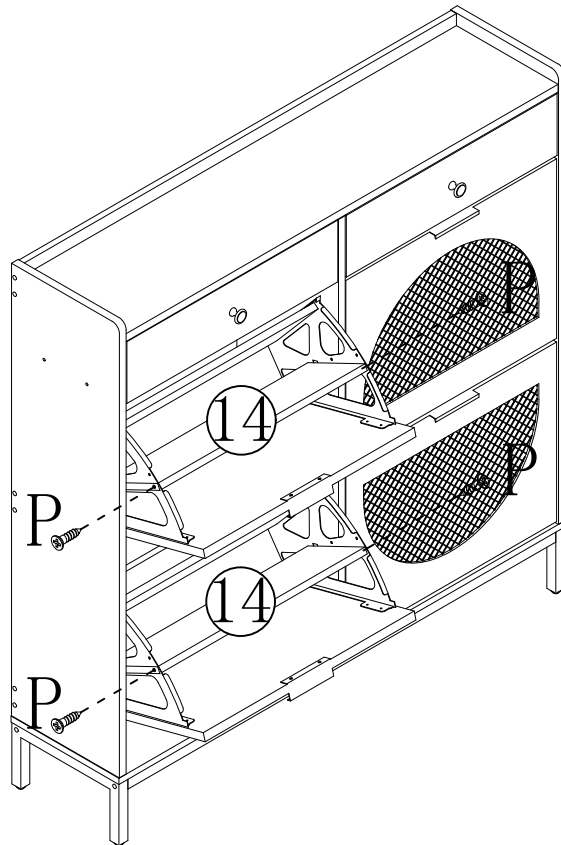

Z 18MM

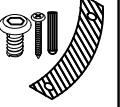

1 PCS

