

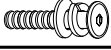



# ASSEMBLY INSTRUCTIONS

**IMPORTANT NOTE :**

- \* PLACE ALL WOODEN PARTS ON A CLEAN AND SMOOTH SURFACE SUCH AS A RUG OR CARPET TO AVOID THE PARTS FROM BEING SCRATCHED.
- \* BEFORE YOU BEGIN, KINDLY FOLLOW THE ASSEMBLY INSTRUCTIONS STEP BY STEP.
- \* DO NOT TIGHTEN ALL SCREWS UNTIL THE CHAIR IS FULLY SET-UP.

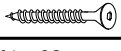
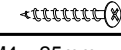
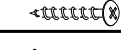
HARDWARE LIST			PART LIST		
A	JCBC M6 x 25mm + S/W M6 + F/W M6 x 13mm 	4PCS	1	LEG RIGHT	1PC
			2	LEG LEFT	1PC
B	JCBC M6 x 55mm + S/W M6 + F/W M6 x 13mm 	4PCS	3	TOP REST	1PC
			4	CHAIR SEAT	1PC
C	JCBC W SCREW M7 x 40mm 	1PC	5	FRONT STRETCHER	1PC
D	PH CB SCREW M4 x 32mm 	2PCS	6	CENTER STRETCHER	1PC
			7	CORNER BLOCK (LONG)	2PCS
E	PH CB SCREW M4 x 25mm 	17PCS	8	CORNER BLOCK (SHORT)	2PCS
F	ALLEN KEY M4 (BALL SHAPE) 	1PC			
G	PROTECTIVE DISC 22MM 	4PCS			

## CAUTIONS :

(1) **DO NOT FULLY-TIGHTEN THE NUT OR NUT BOLTS INITIALLY UNTIL ALL NUTS OR BOLT IS READY ASSEMBLED.**

(TO AVOID CAUSING DAMAGES TO THE THREAD, DO NOT OVER-TIGHTEN THE NUTS OR BOLTS.)

(2) **KEEP ALL HARDWARE PART OUT OF REACH OF CHILDREN.**

## STEP 1

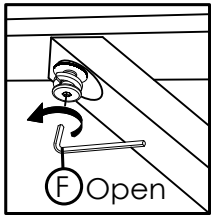

**BEFORE ASSEMBLY PLEASE OPEN THE CENTER STRETCHER.**

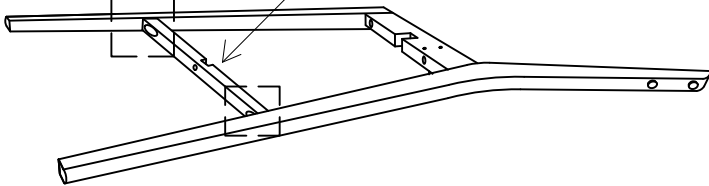

## STEP 2

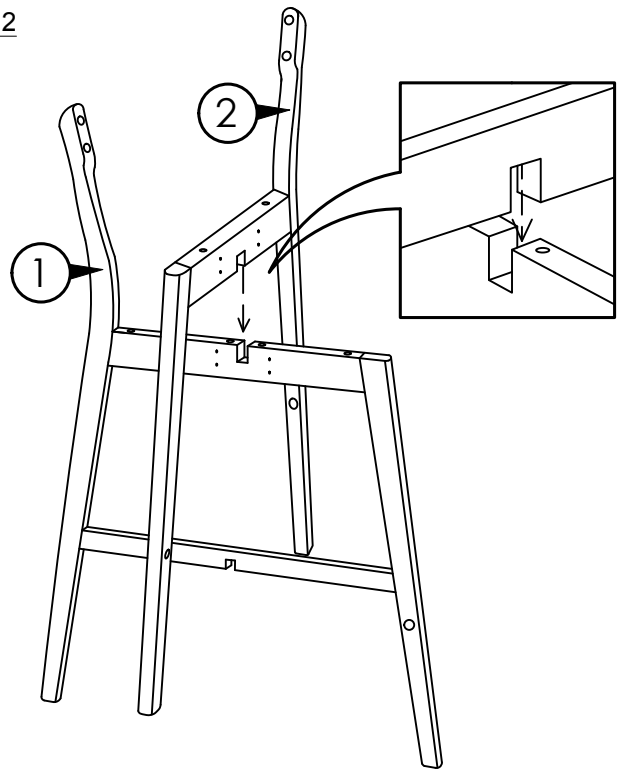

## STEP 3

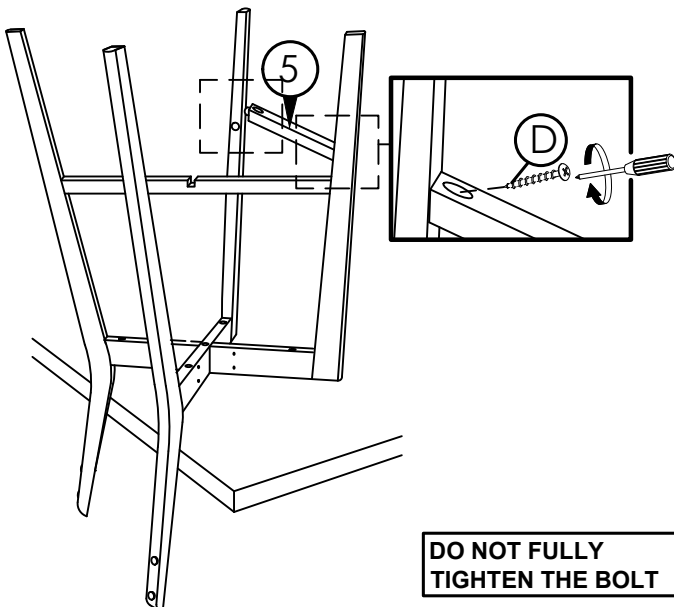

**DO NOT FULLY TIGHTEN THE BOLT**

## STEP 4

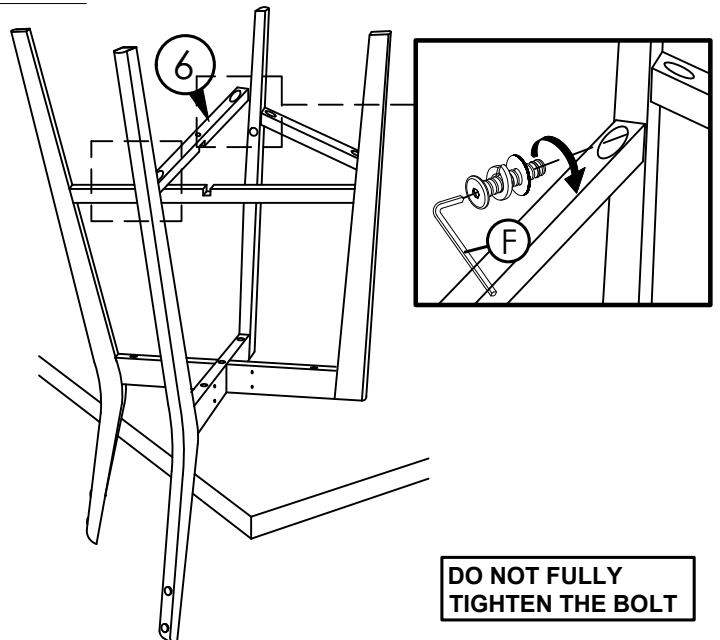

**DO NOT FULLY TIGHTEN THE BOLT**

# ASSEMBLY INSTRUCTIONS

## STEP 5

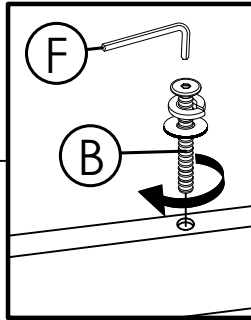
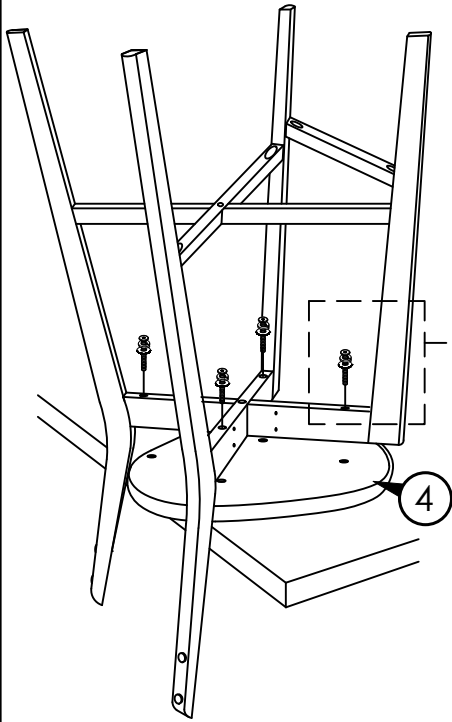

**DO NOT FULLY  
TIGHTEN THE BOLT**

## STEP 6

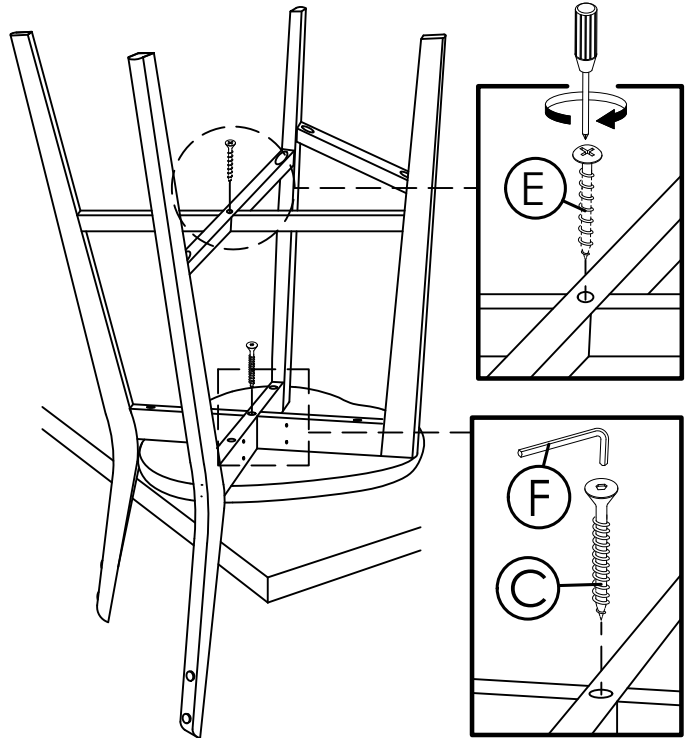

## STEP 7

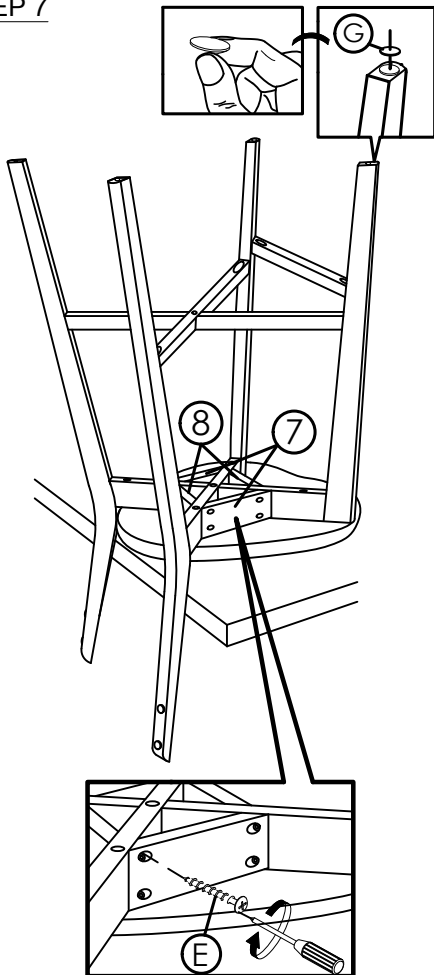

**DO NOT FULLY TIGHTEN THE SCREW**

## STEP 8

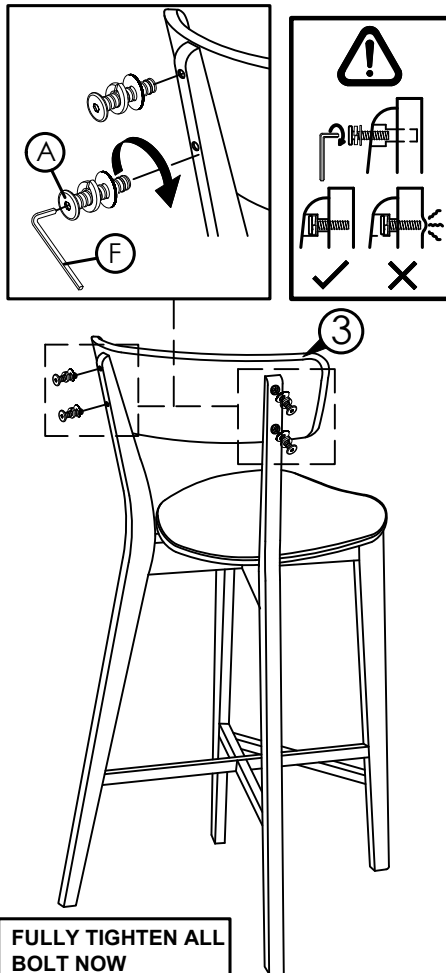

**FULLY TIGHTEN ALL  
BOLT NOW**

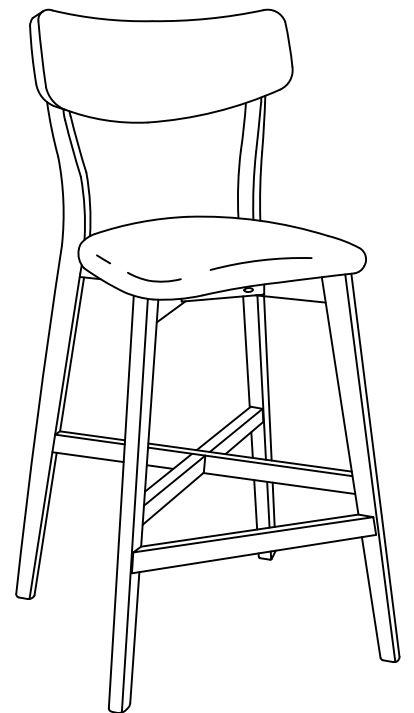

**COMPLETED  
BARSTOOL ASSEMBLY.**