













Installation & Assembly

PARTS LIST

NO.	DESCRIPTION	SKETCH	QTY
A	FRONT LEGS		2PCS
B	SEAT FRAME		1PC
C	CHAIR BACK		1PC
D	FRONT STRETCHER		1PC
E	SIDE STRETCHER		2PCS

HARDWARE LIST

N O .	DESCRIPTION	SKETCH	Q T Y
F	WRENCH 5MM		1PC
I	BOLT Ø5/16" *3-1/2"		4PCS
J	BOLT Ø5/16" *2"		5PCS
K	LOCK WASHER 5/16" *22MM		9PCS
L	FLAT WASHER 5/16"		9PCS
M	WOOD DOWEL Ø10*30mm		2PCS
N	SCREWS 50mm		6PCS

STEP:1

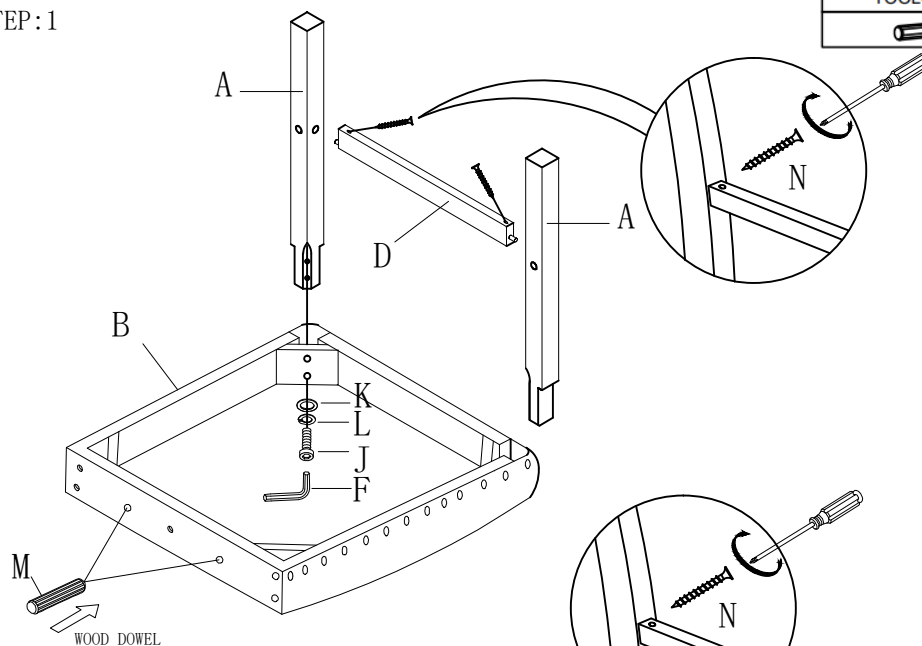

TOOLS REQUIRED (NOT PROVIDED)
 Phillips Screw Driver

Please balance all 4 chair legs on the same level & tighten all the screws.

STEP:3

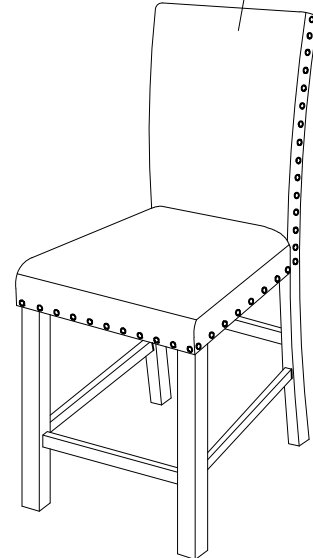

STEP:2

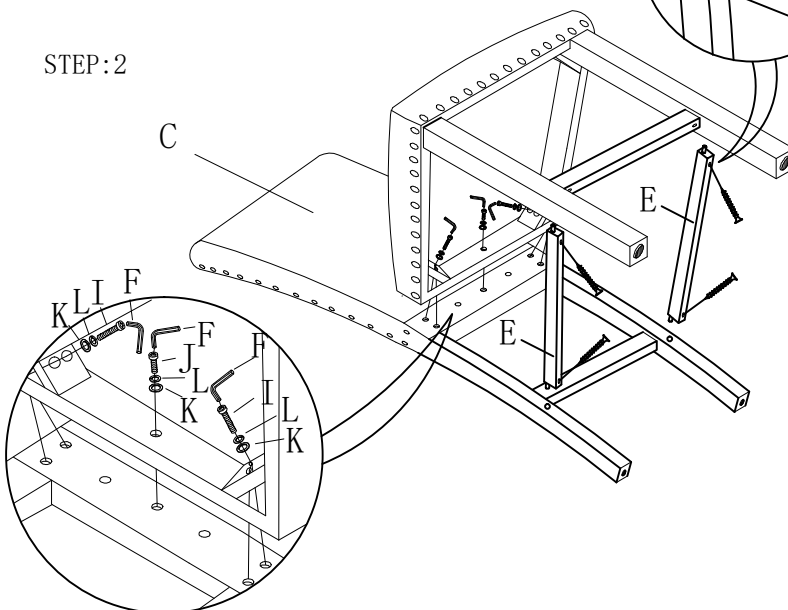

Caution: Please do not tighten all bolts until the chair is completely assembled!

MADE IN VIETNAM