







ASSEMBLY INSTRUCTIONS

**KEEP THIS DOCUMENT FOR REFERENCE IN CASE PARTS ARE NEEDED
DO NOT TIGHTEN SCREWS UNTIL COMPLETELY ASSEMBLED !**

No.	DESCRIPTION	Q'TY
A	TABLE TOP	1pc
B	TABLE POST	4pc
C	TOP PANEL	1pc
D	BOTTOM PANEL	1pc

No.	DESCRIPTION	Q'TY
1	BOLT(5/16"x2-1/2") 	4pcs
2	BOLT(5/16"x1-1/2") 	12pcs
3	NUT(5/16") 	4pcs
4	SPRING WASHER(5/16") 	20pcs
5	METAL WASHER(5/16") 	20pcs
6	ALLEN KEY 	1pc
7	ALLE WRENCH 	1pc

STEP 1 (x2)

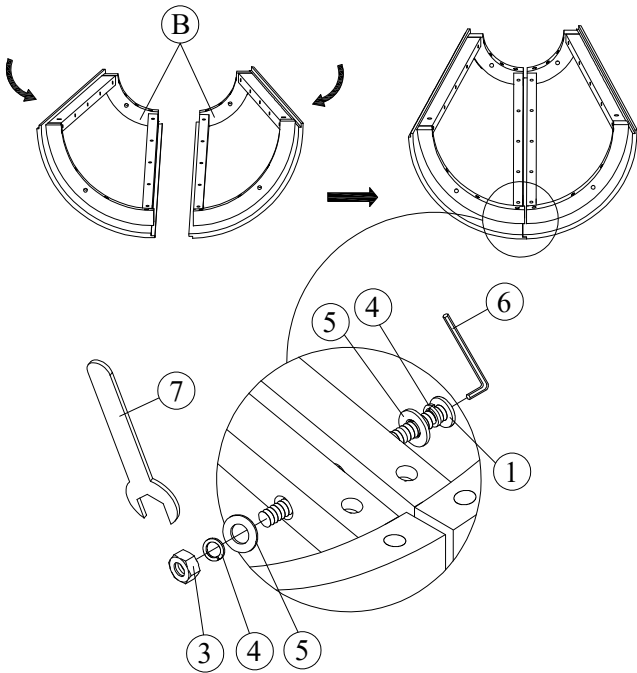

STEP 2

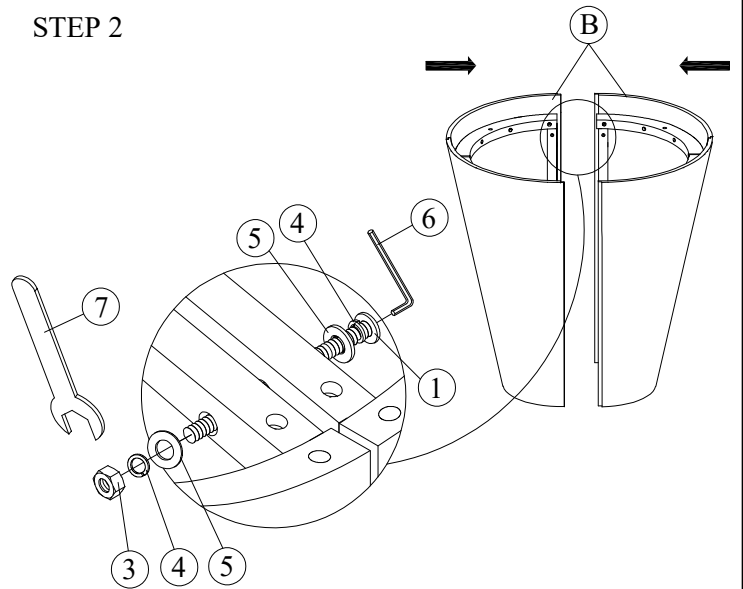

STEP 3

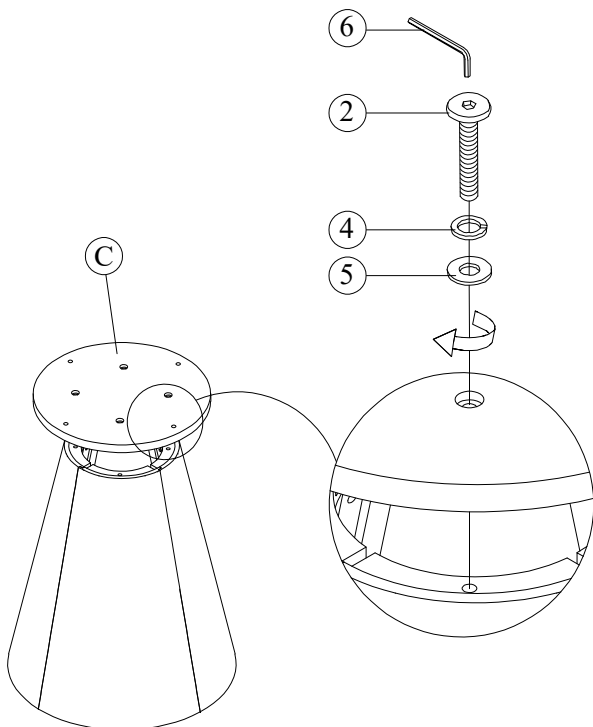

STEP 4

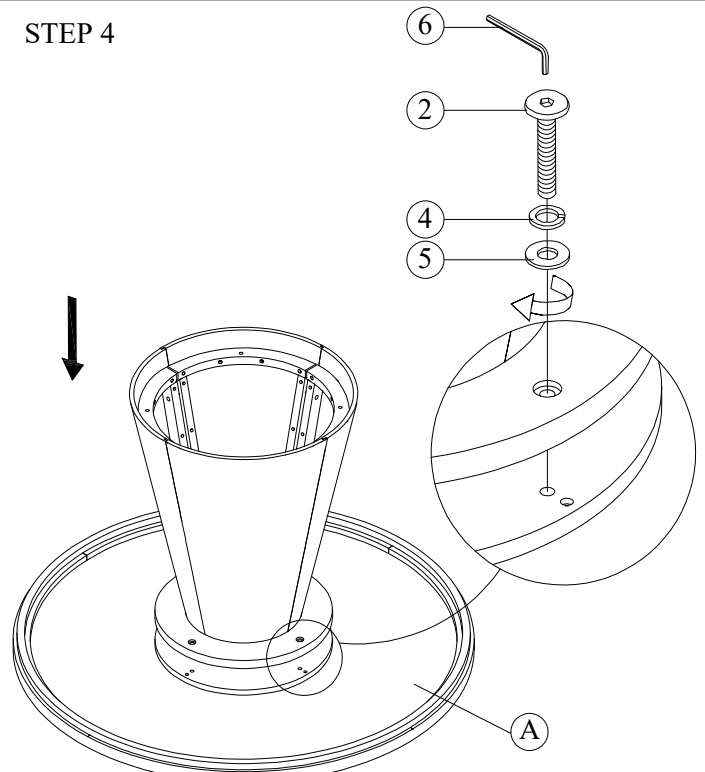

STEP 5

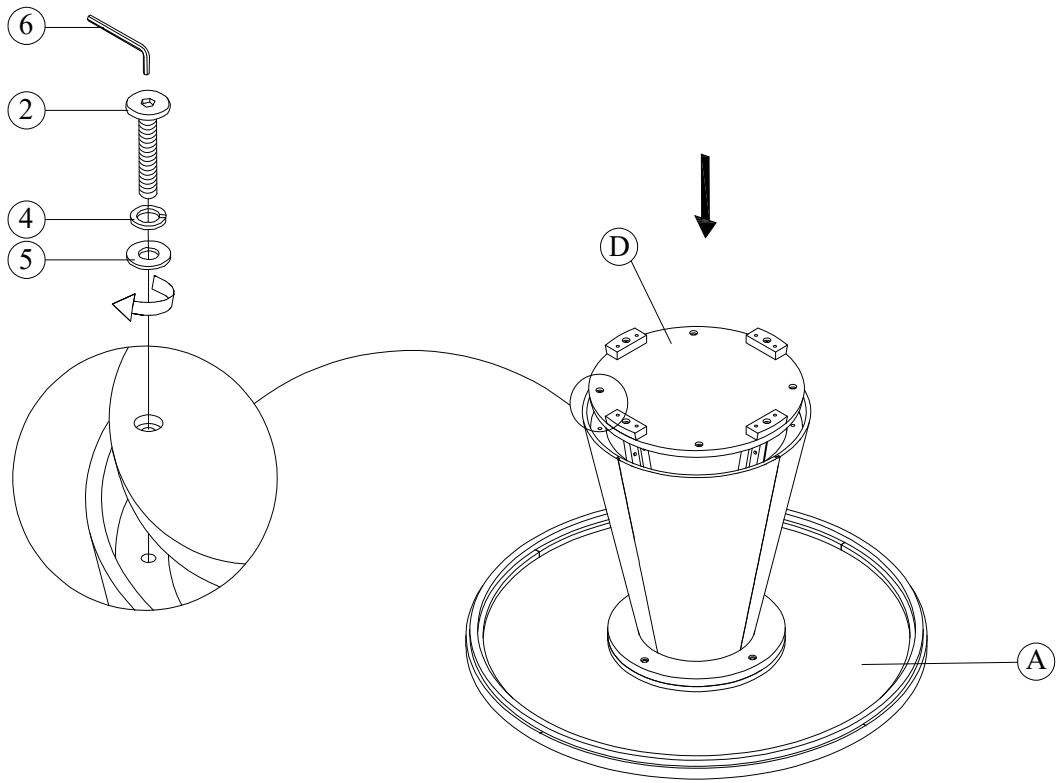

STEP 6

