

Assembly Instruction

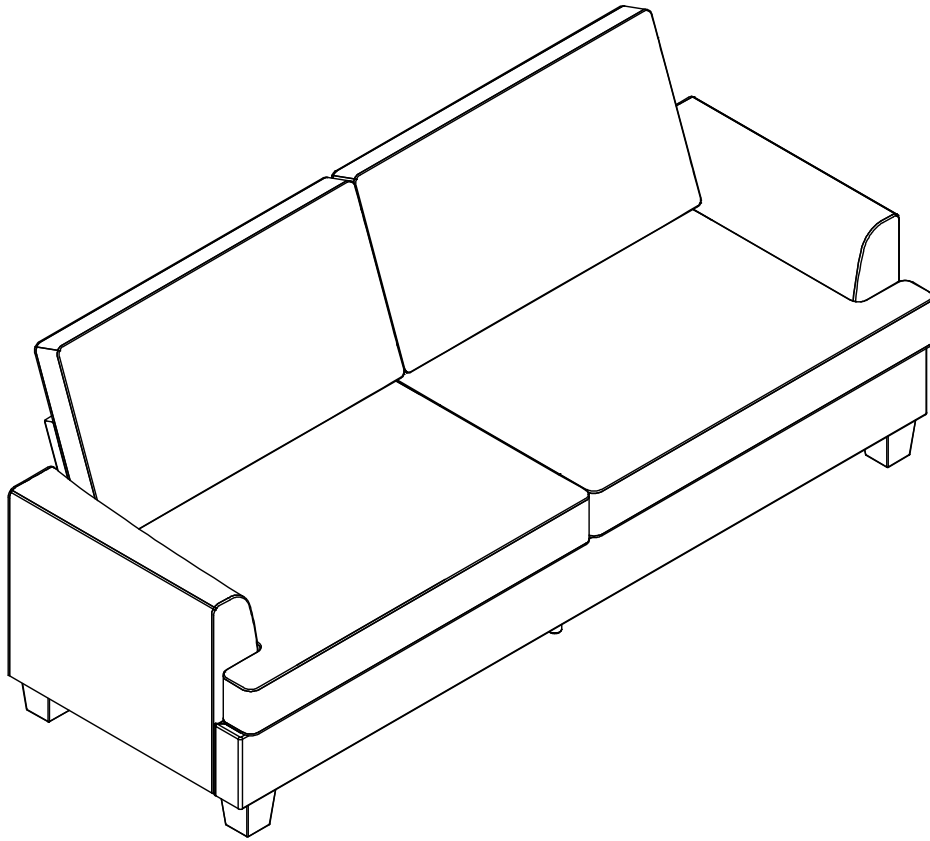

PARTS

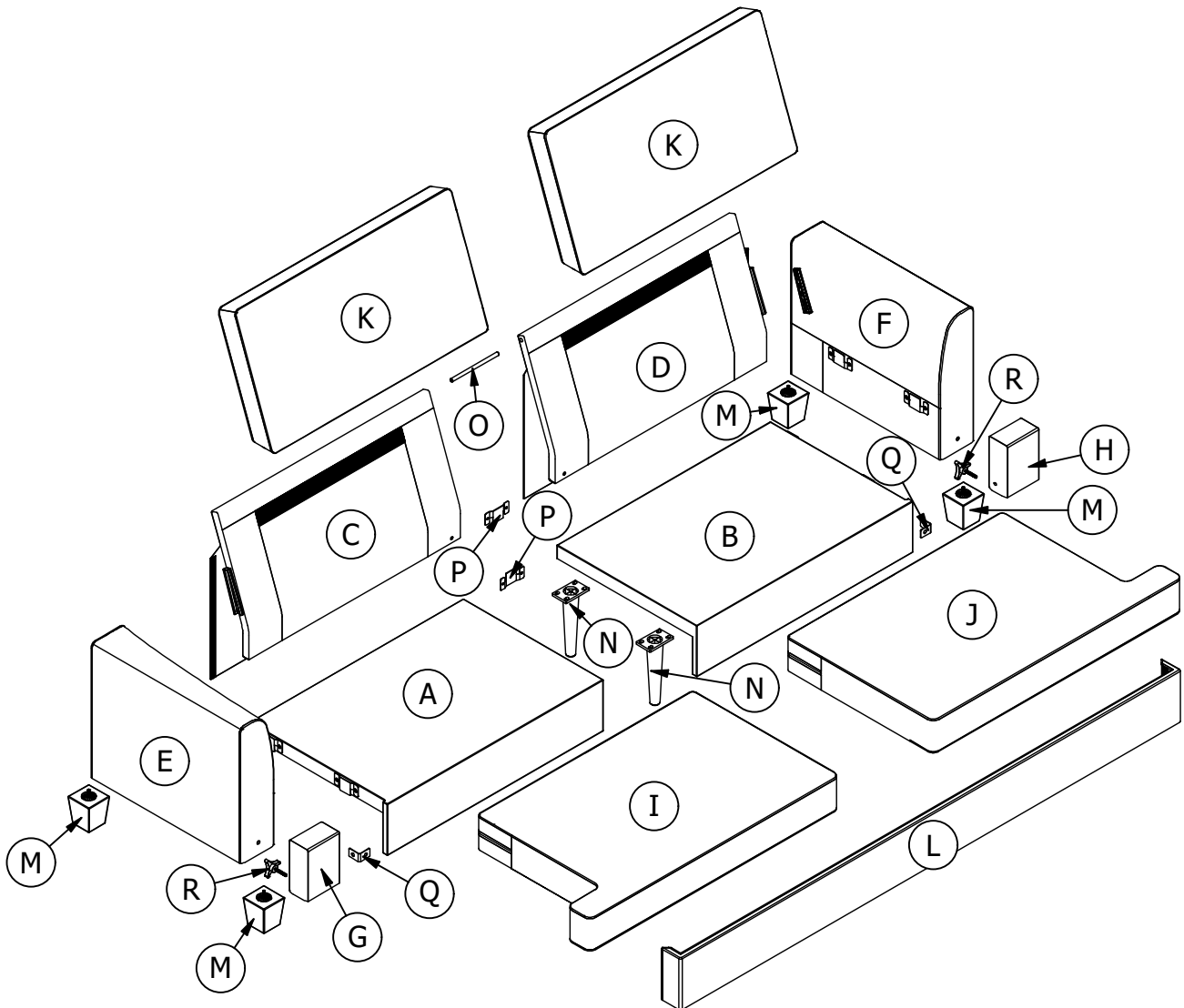

PARTS LIST

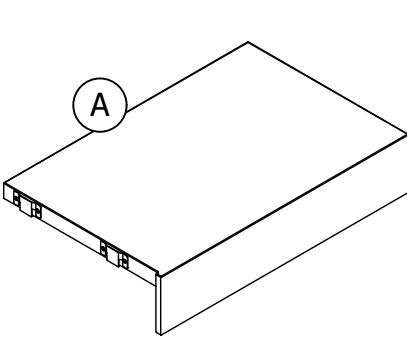

A
Left Seat Frame
X 1 PC

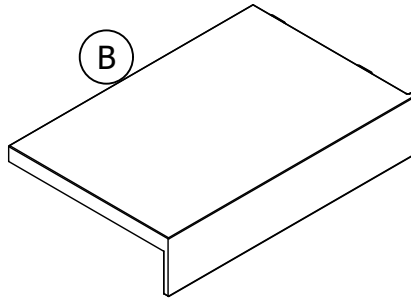

B
Right Seat Frame
X 1 PC

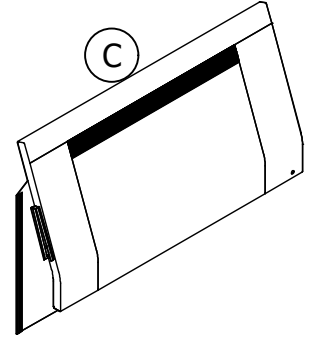

C
Left Back Frame
X 1 PC

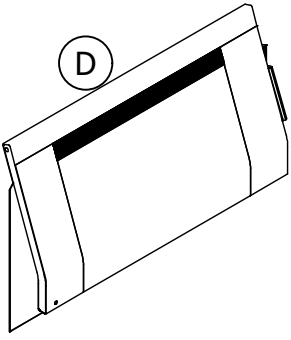

D
Right Back Frame
X 1 PC

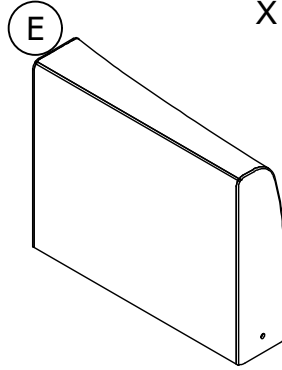

E
Left Armrest
X 1 PC

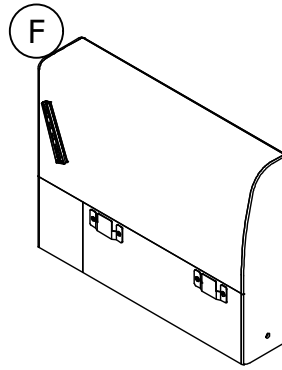

F
Right Armrest
X 1 PC

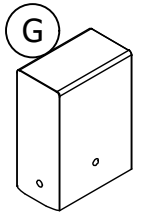

G
Front of Left Armrest
X 1 PC

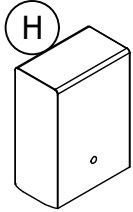

H
Front of Right Armrest
X 1 PC

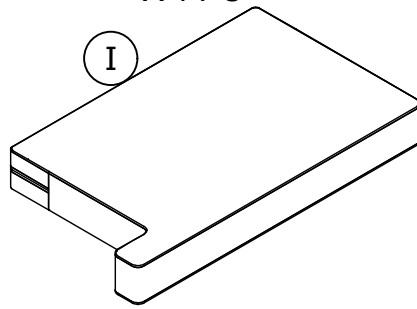

I
Left Seat Cushion
X 1 PC

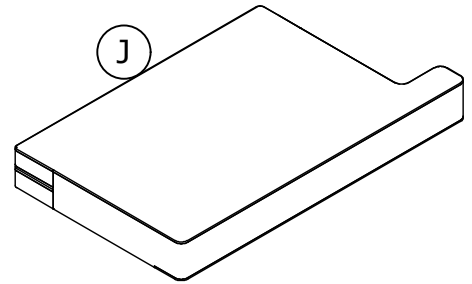

J
Right Seat Cushion
X 1 PC

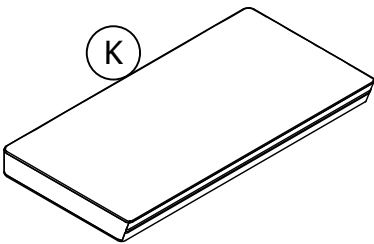

K
Back Cushion
X 2 PCS

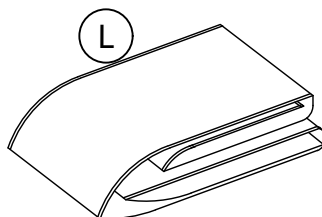

L
Front Cover
X 1 PC

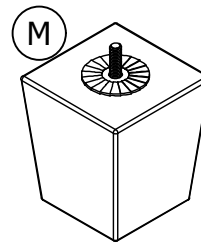

M
Leg
X 4 PCS

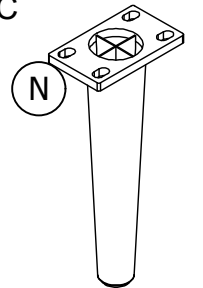

N
Middle Leg
X 2 PCS

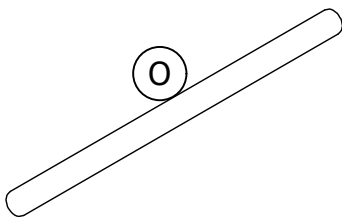

O
Connector
X 1 PC

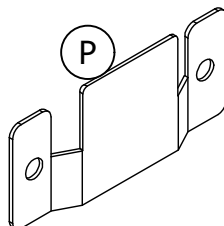

P
Plug-in
X 2 PCS

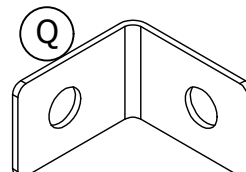

Q
Bracket
X 2 PCS

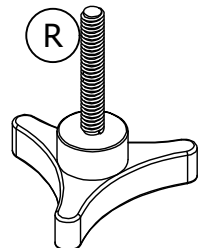

R
Bolt
X 2 PCS

HARDWARE

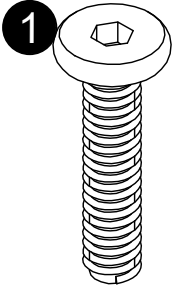

5/16" X 35mm Bolt
X 8

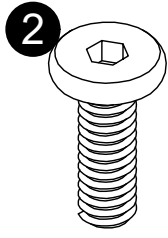

5/16" X 23mm Bolt
X 8

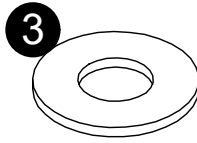

Washer
X 12

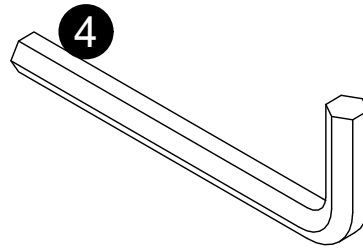

Allen Key
X 1

STEP 1:

Some parts will be found in the compartment under the Armrests, as shown.

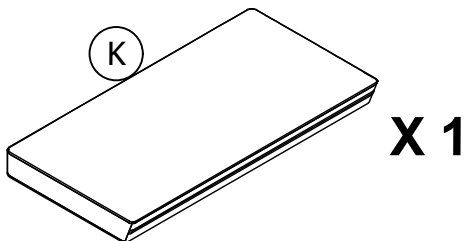
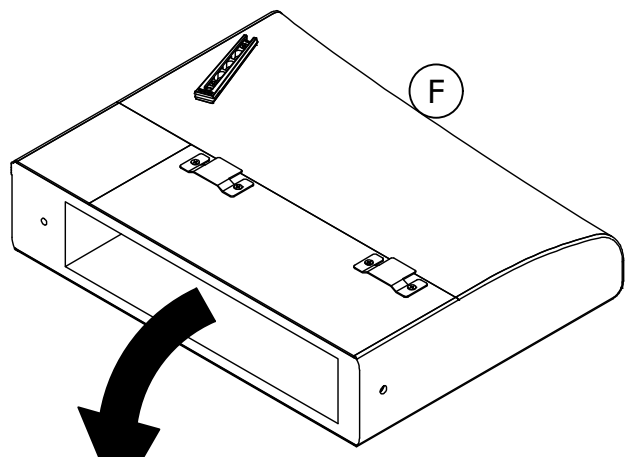
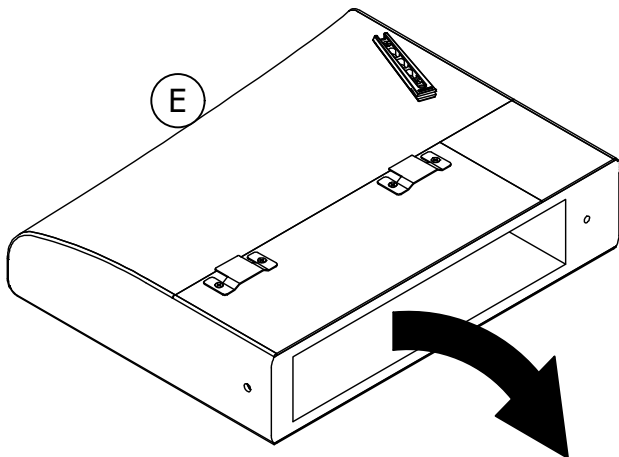

X 1

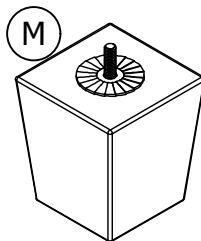

X 4

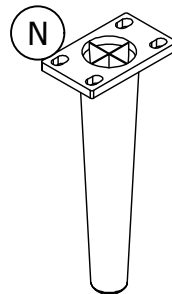

X 2

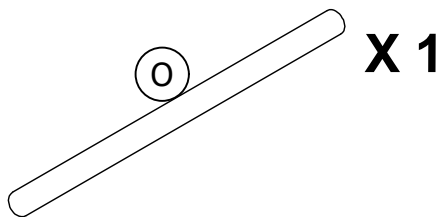

X 1

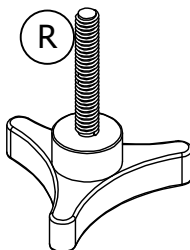

X 2

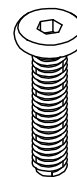

All of the
Hardware

STEP 2:

Attach arm **G** & **H** to arm **E** & **F** with bolt **R** x 2 , as shown.

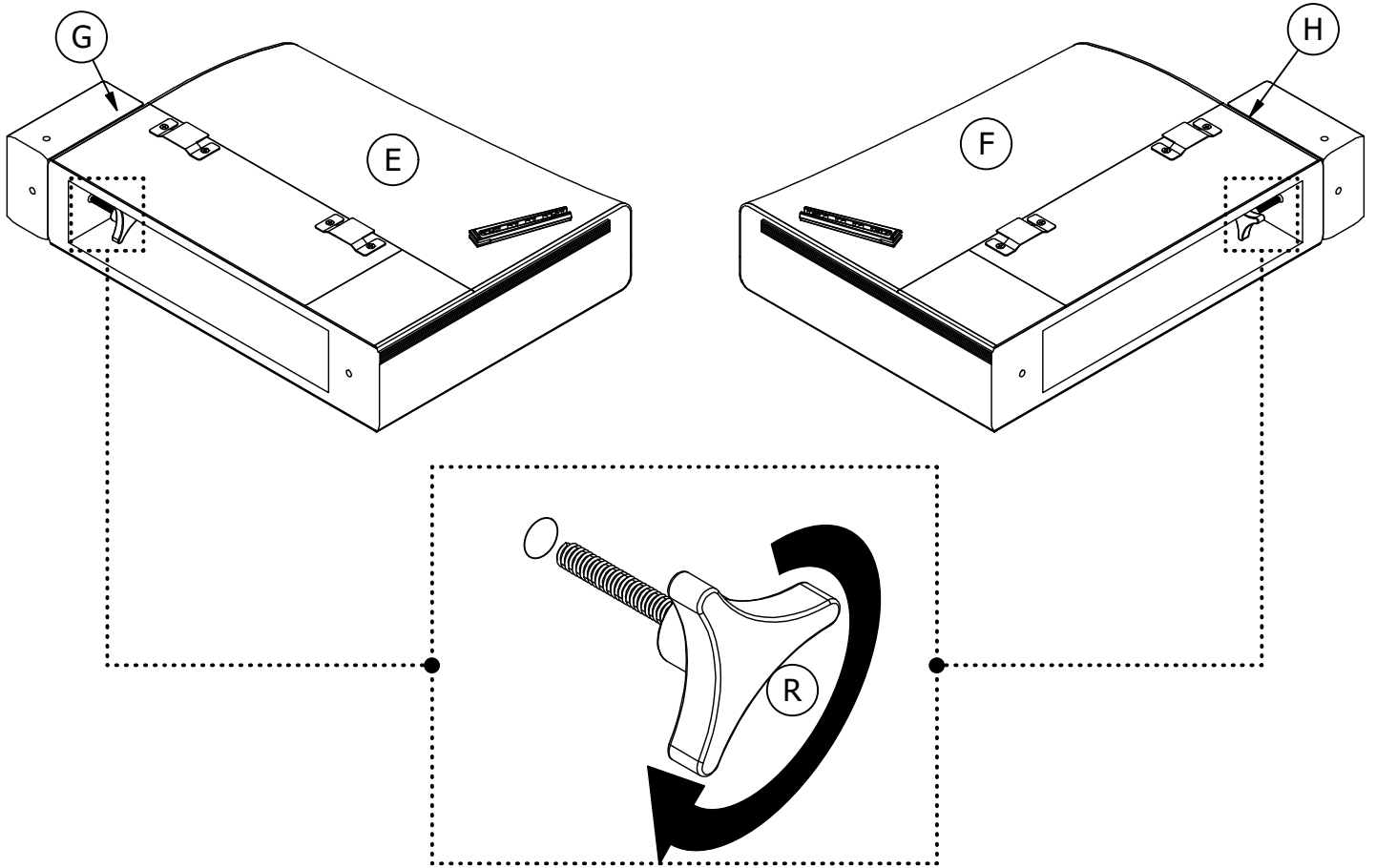

STEP 3:

Manually screw leg **M** x 4 to arms **E**, **F**, **G** & **H**, as shown.

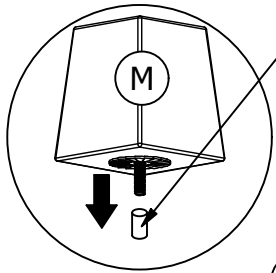

▲ Please remove the protective cap on the tip of thread before assembling.

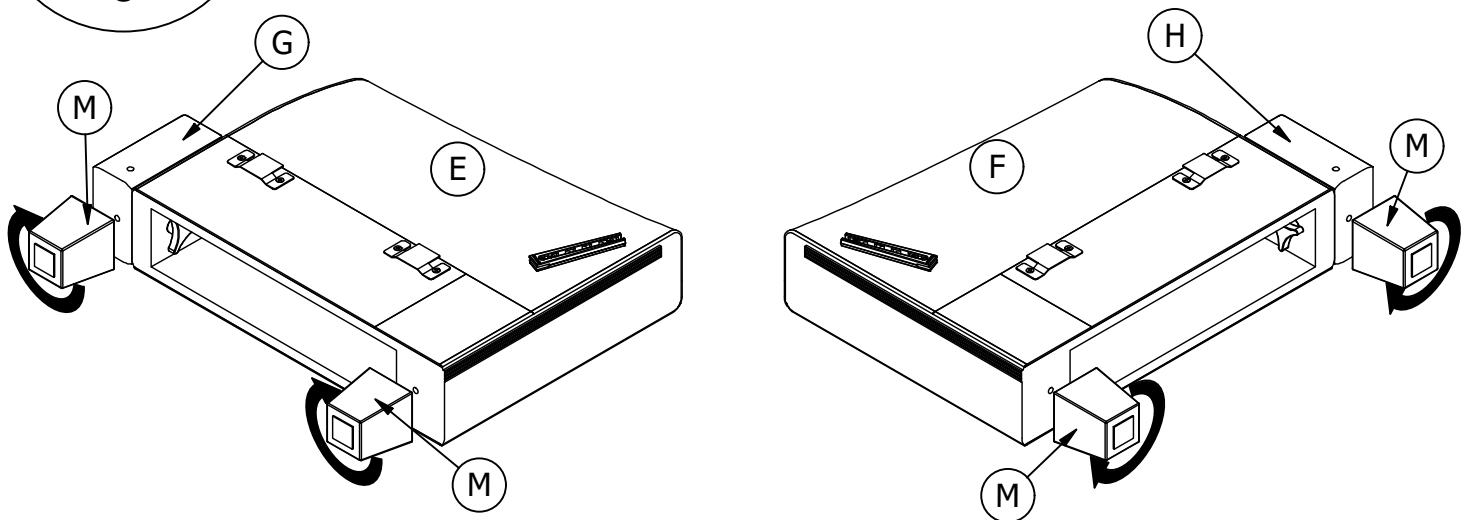

STEP 4:

Attach middle leg **N** x 2 to seat **A** & **B** with bolts **1** and flat washers **3**, as shown.

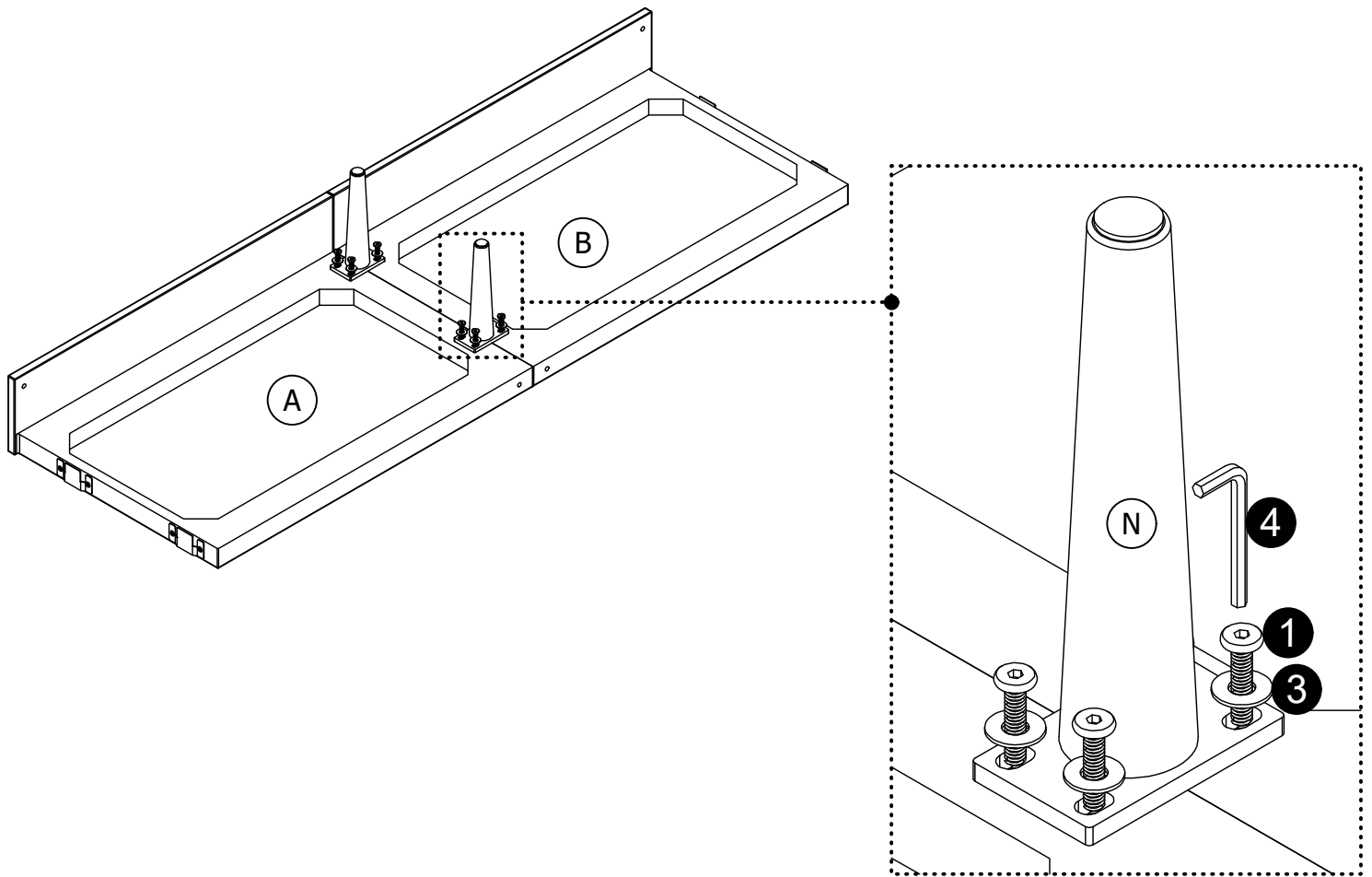

STEP 5:

Attach Plug-in **P** to seat **A** & **B** with bolt **2**, as shown.

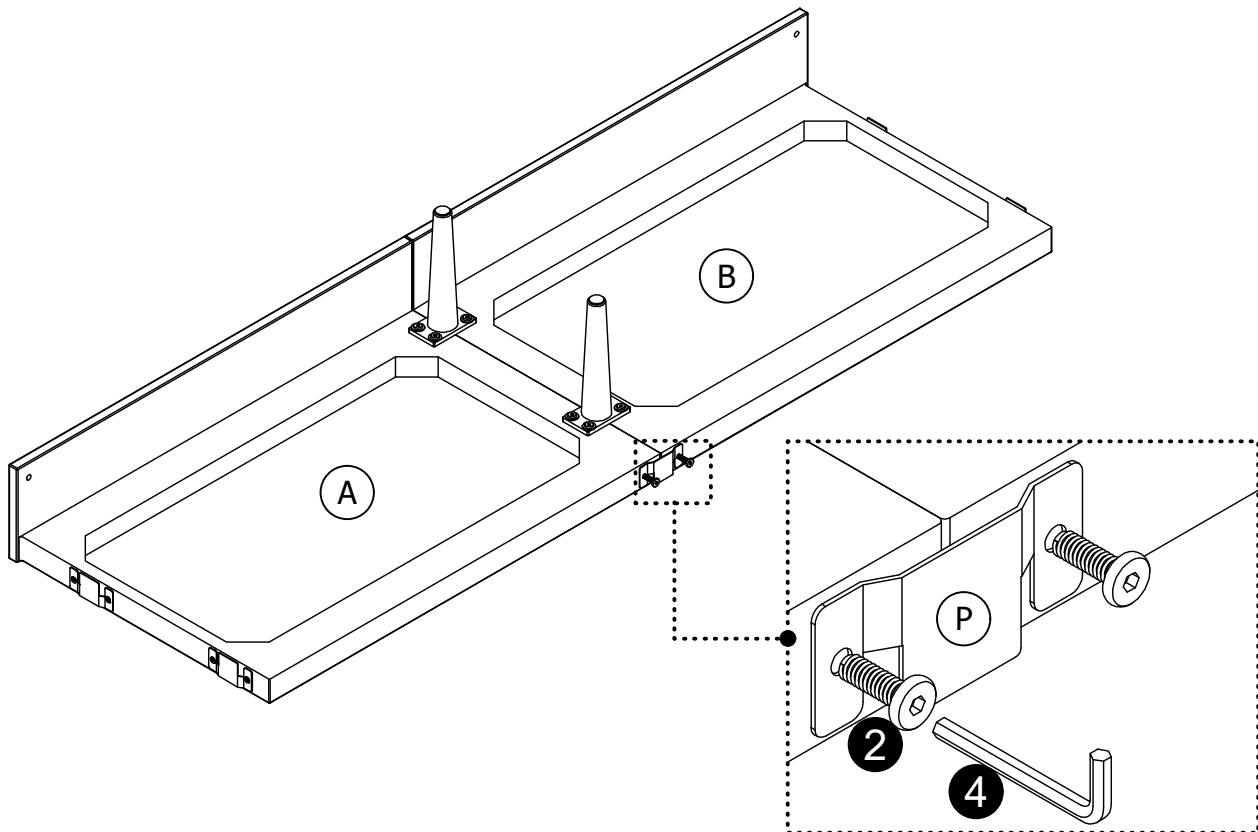

STEP 6:

Attach Bracket **Q** x 2 to seat **A** & **B** with bolts **2** and flat washers **3**, as shown.

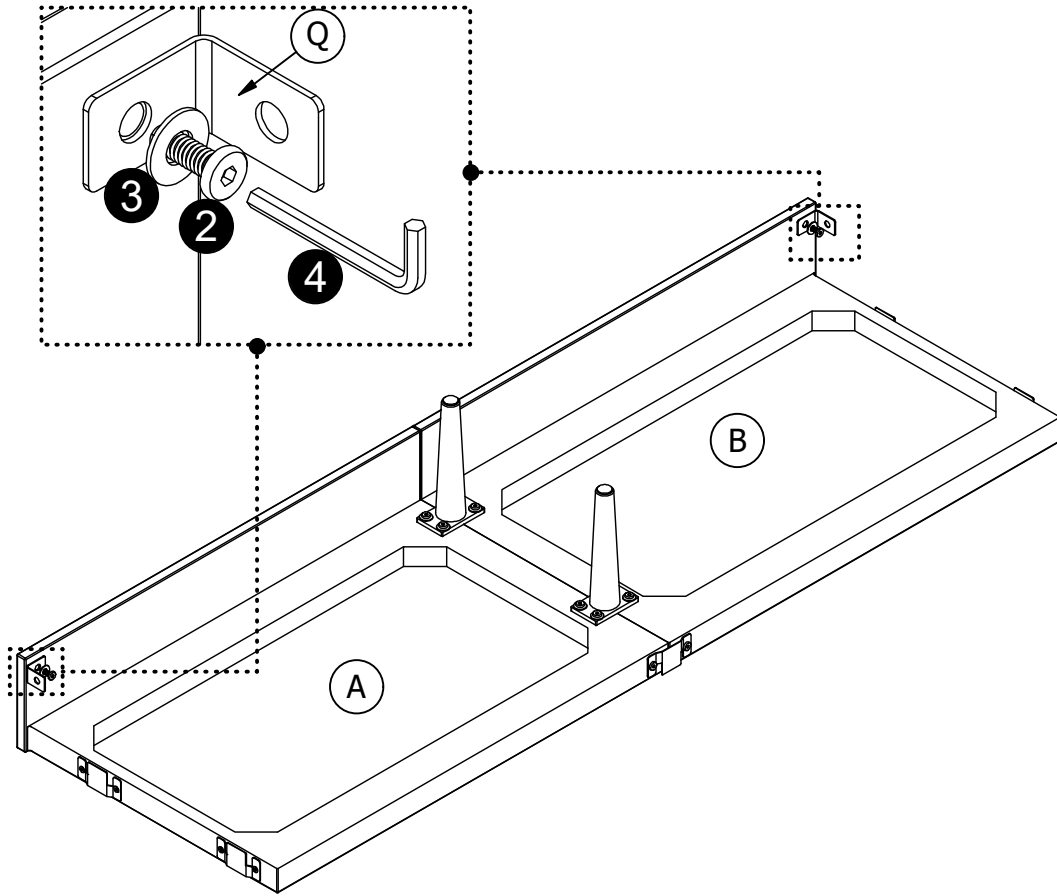

STEP 7:

Attach seat **A** & **B** to arms **E** & **F** by inserting the brackets on seat **A** & **B** into the metal glides on arms **E** & **F**.

Push seat **A** & **B** downwards to secure it into place.

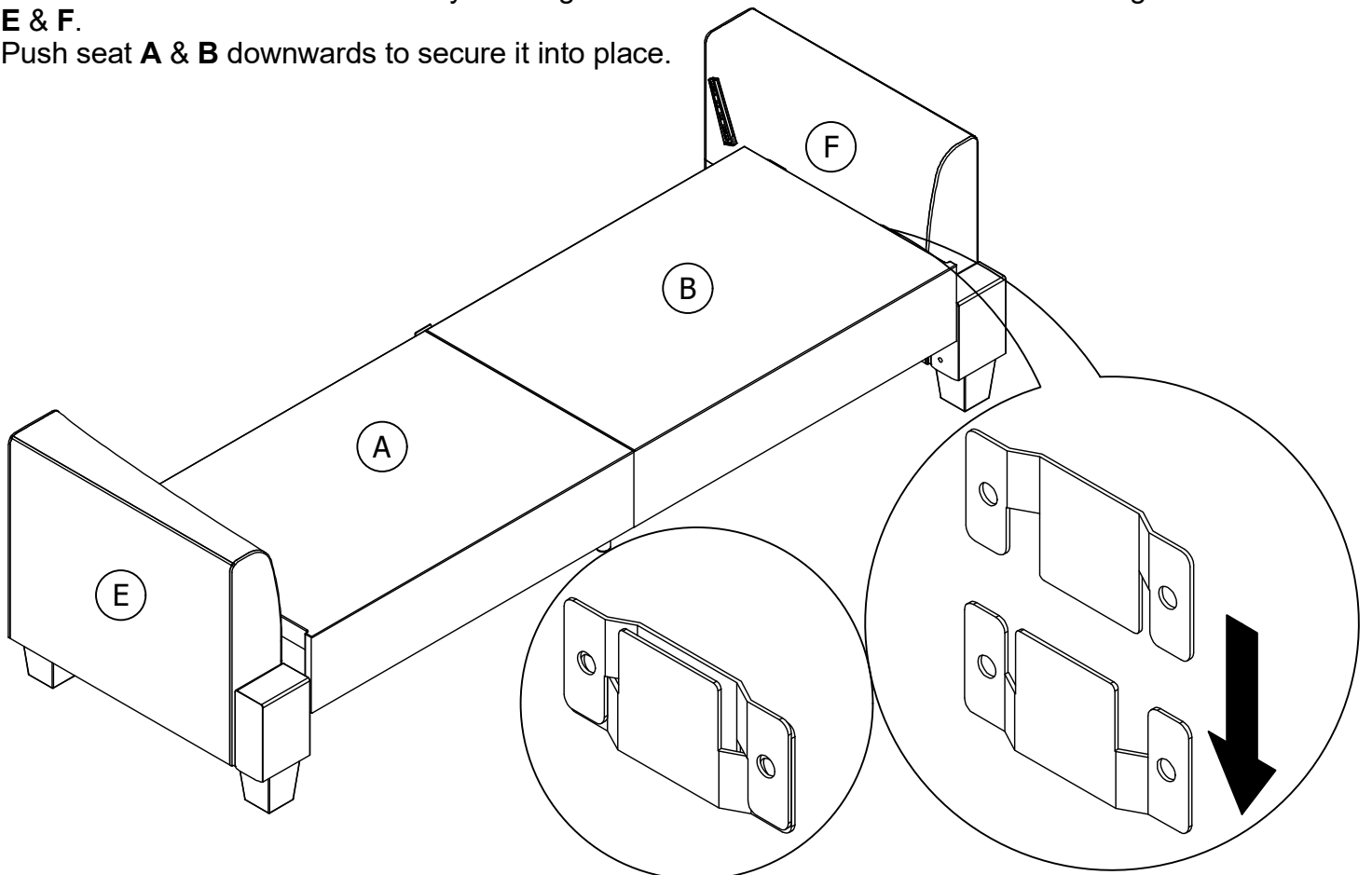

STEP 8:

Attach Bracket **Q** x 2 to arms **G** & **H** with bolts **2**, and flat washers **3**, as shown.

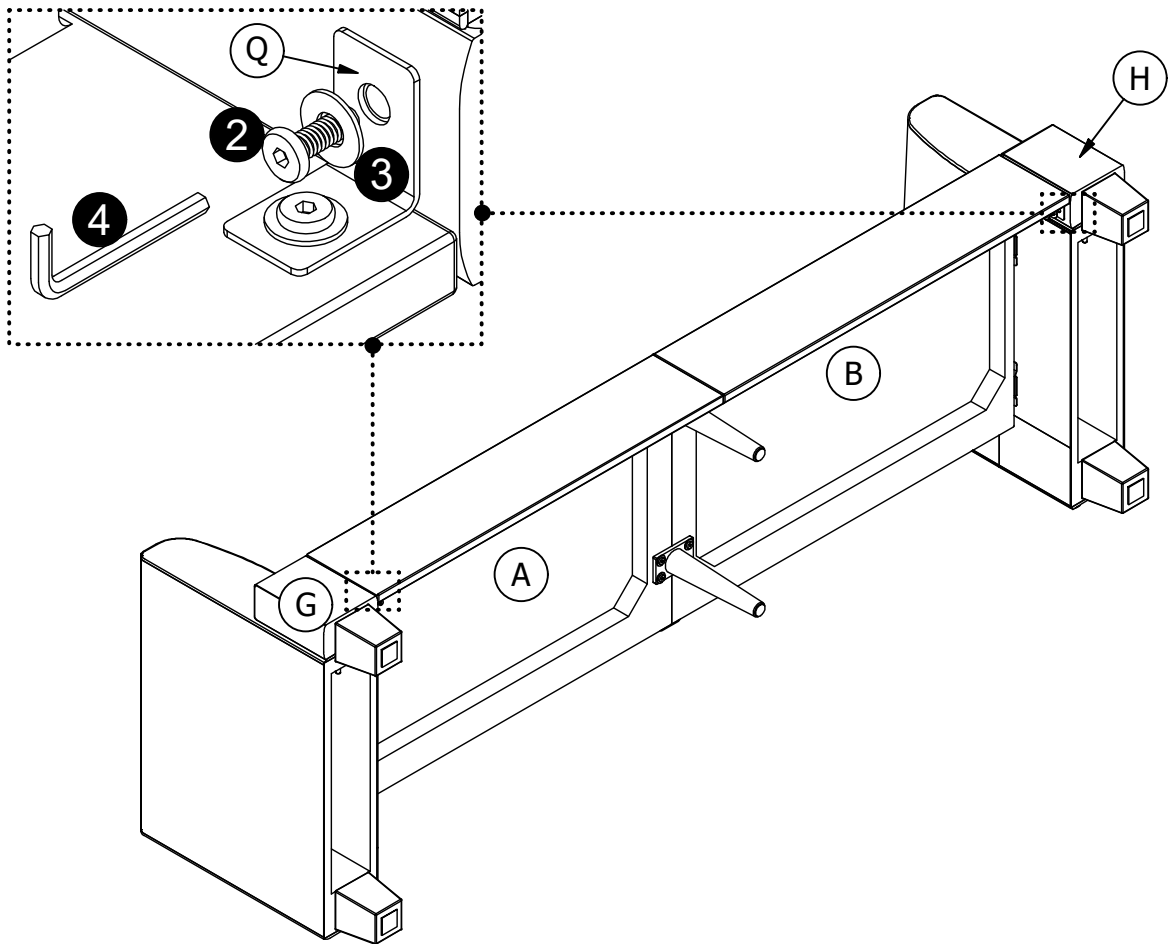

STEP 9:

Secure Front Cover **L** to front of the assembled sofa with the hook and loop fastener.

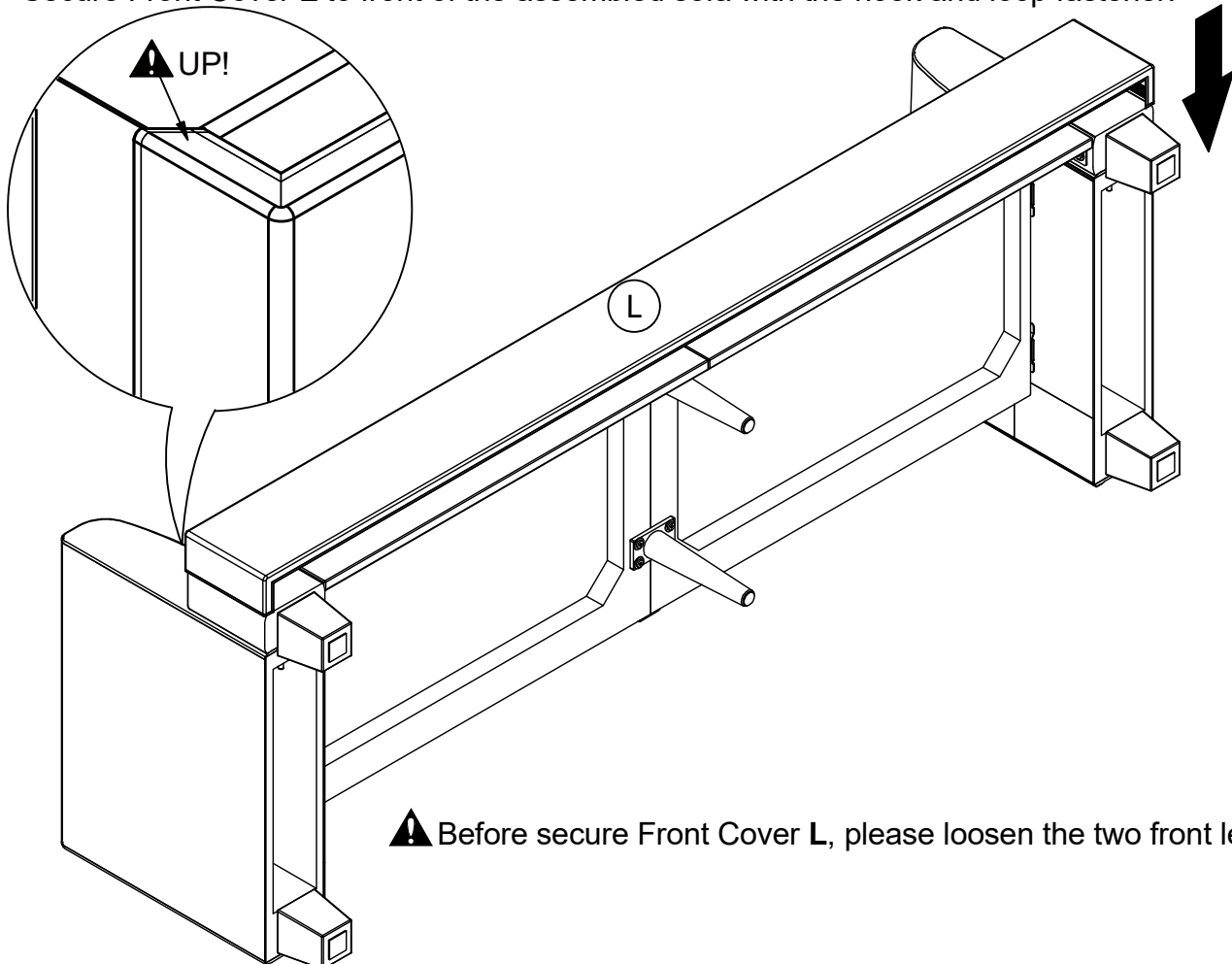

⚠ Before secure Front Cover **L**, please loosen the two front legs first.

STEP 10:

Connect Backs **C** & **D** using Connector **O**, as shown.

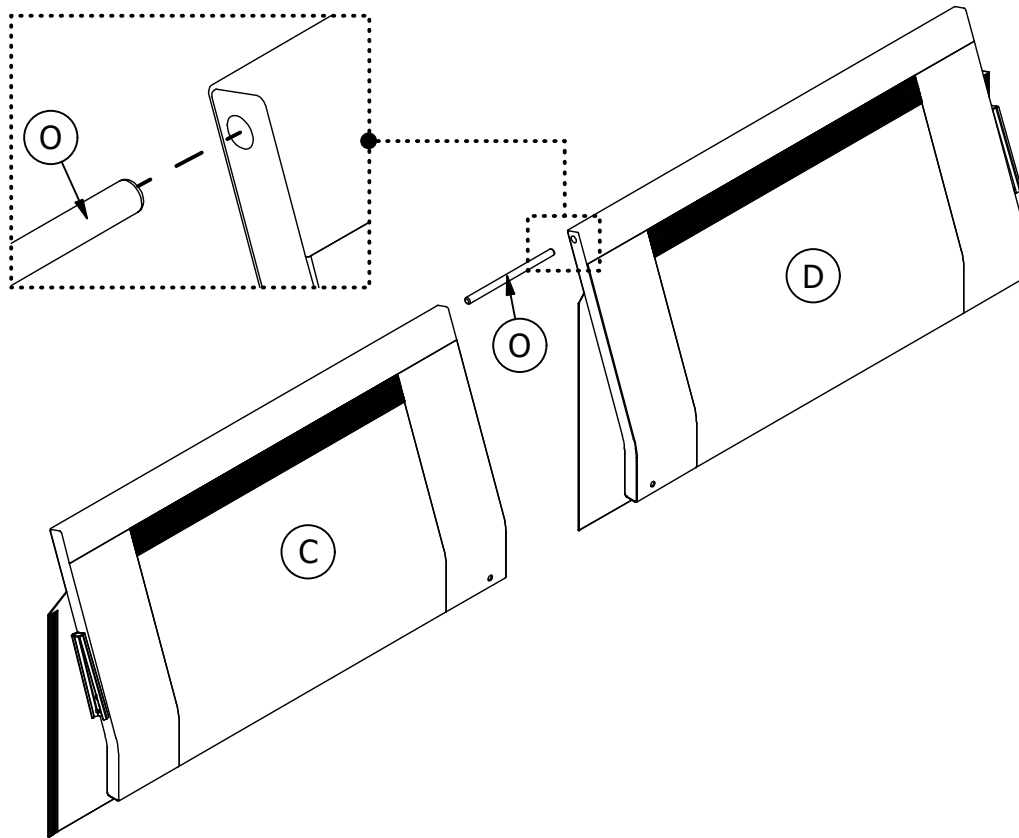

STEP 11:

Attach Plug-in **P** to back **C** & **D** with bolt **2**, as shown.

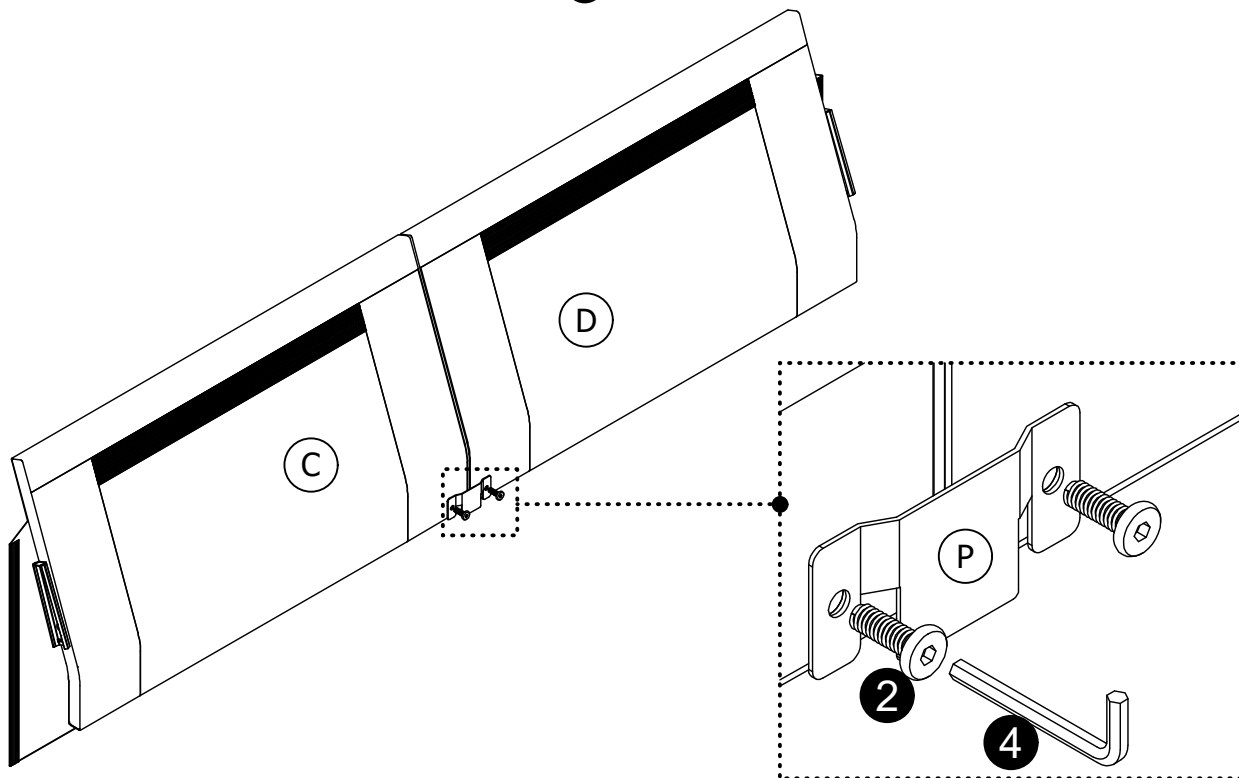

STEP 12:

Attach Backs **C** & **D** to Armrests **E** & **F** by inserting the brackets on Backs **C** & **D** to the metal glides on Armrests **E** & **F**.

Attach Backs **C** & **D** to Double Seat **A** & **B** by inserting the Plug-in **P** on Backs **C** & **D** into the Plug-in **P** on Double Seat **A** & **B**.

Push Backs **C** & **D** downwards to secure it into place.

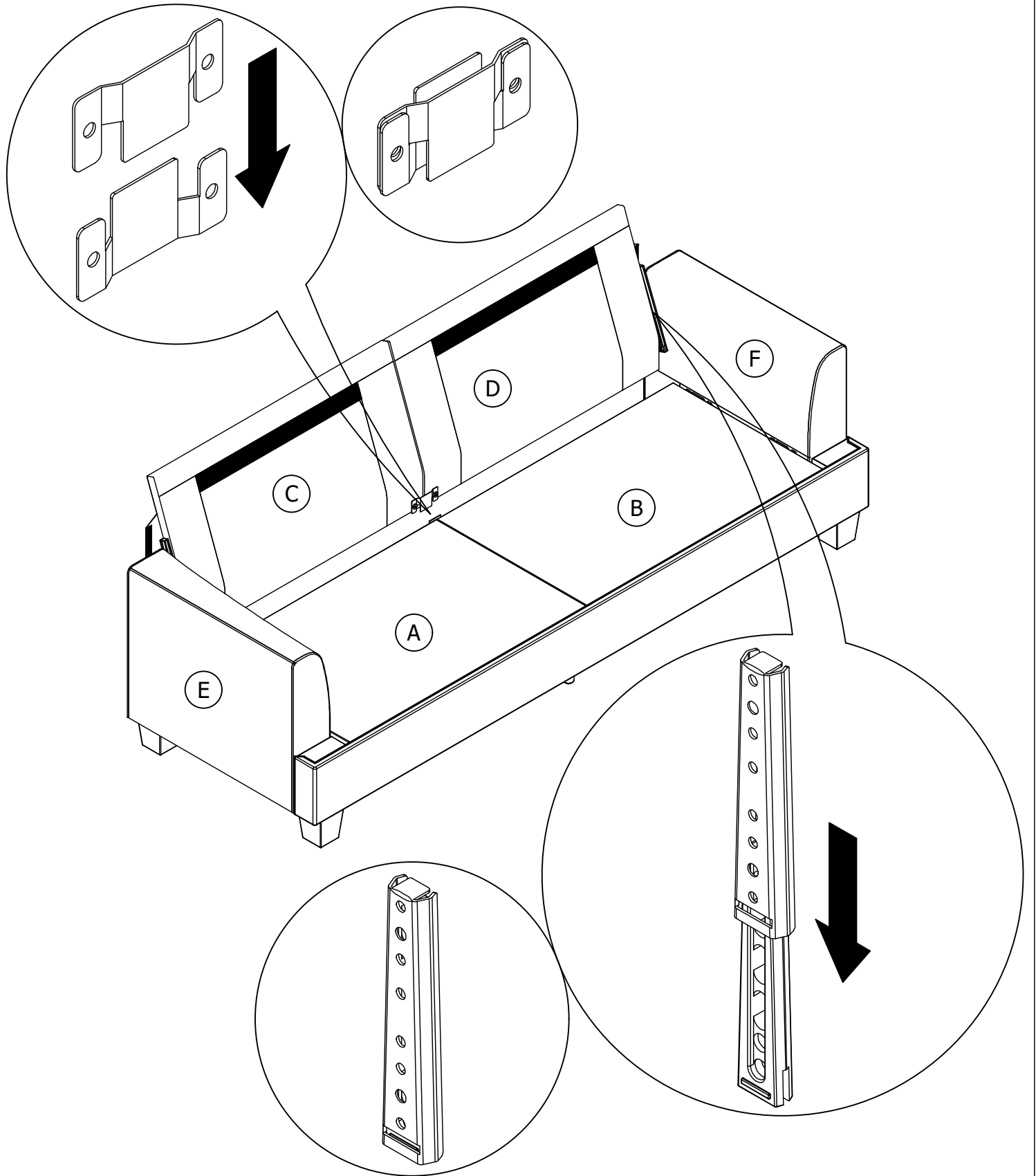

STEP 13:

Stick fabric cover on Backs **C** & **D** to Armrests **E** & **F** with the hook and loop fastener. Stick fabric cover on Left Back Frame **C** to Right Back Frame **D** with the hook and loop fastener, as shown.

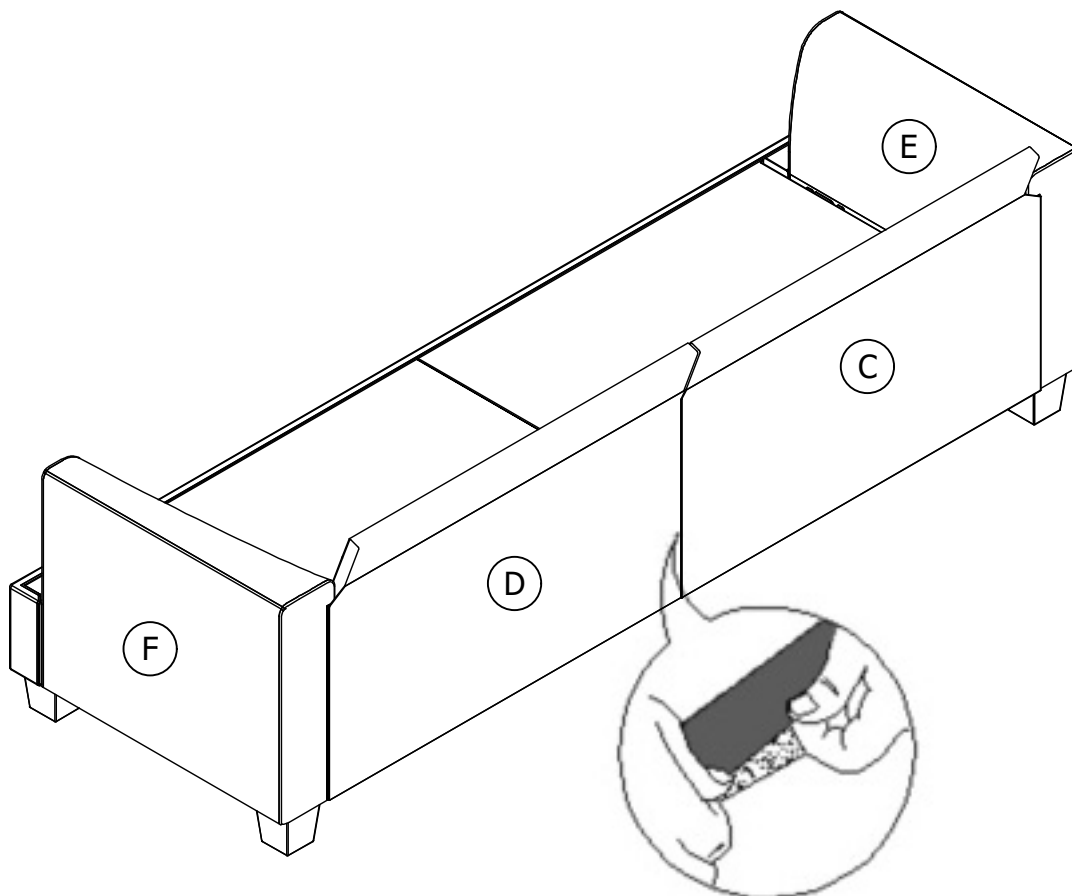

STEP 14:

Remove the cushions from their vacuum sealed package.

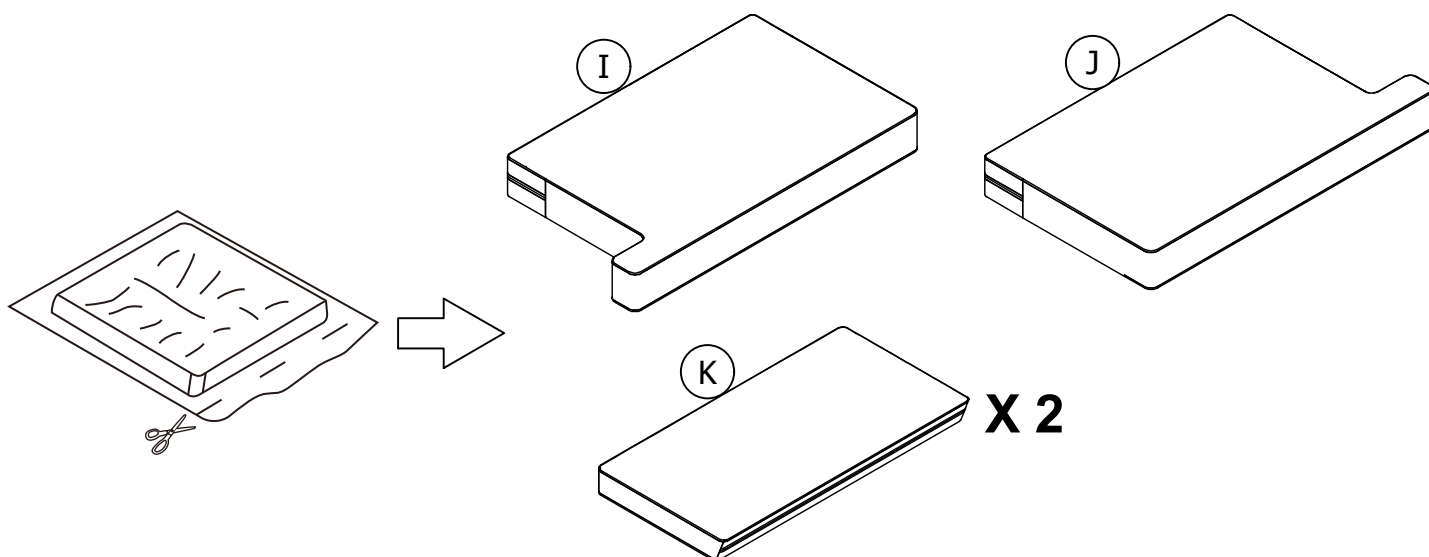

⚠ Note: The cushions have been vacuum packed for transportation purposes. After unpacking, please allow up to 72 hours so that they can return to their original shape.

STEP 15:

Place Seat Cushions **I**, **J** & Back Cushions **K** x 2 onto the sofa.

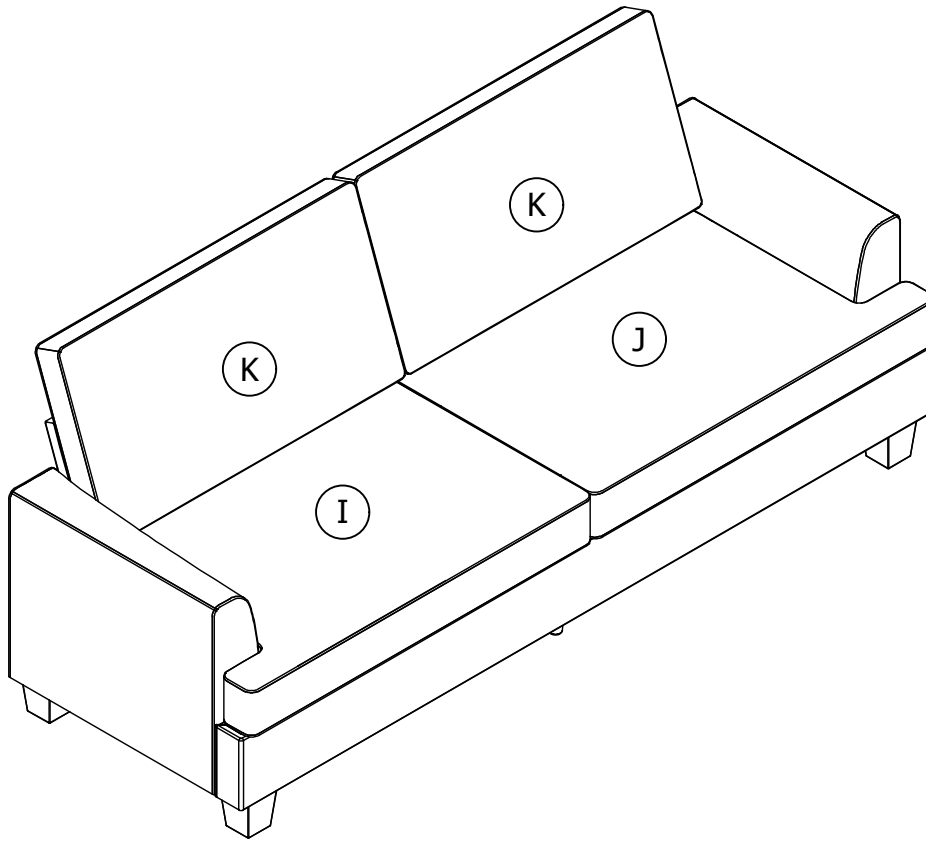

Helpful Hints

- Your futon can transform between a Sofa and a Bed.
- Move your new furniture carefully, with two people lifting and carrying the unit to its new location.
- Your furniture can be disassembled and reassembled to move.
- Clean the product with a soft damp cloth. DO NOT use harsh chemicals or abrasive cleaners.
- For further information please contact at sales4@jsanyee.com

