

OWNER'S MANUAL

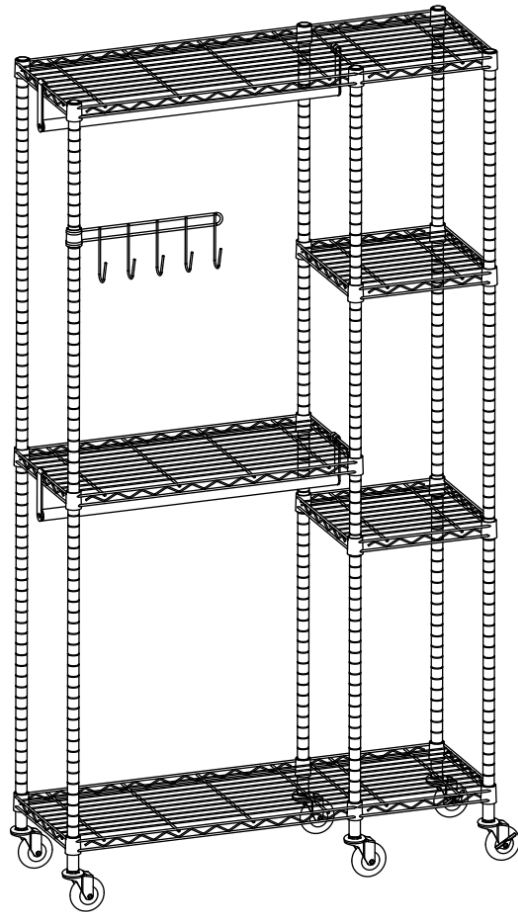

MOBILE CLOSET ORGANIZER

PARTS LIST

Your Mobile Closet Organizer should include the following parts. Please inspect box contents to ensure you have received all components.

If you are missing any parts, need assistance with assembly or have questions, please contact our Customer Service. Parts can also be requested online



A
LARGE SHELF (2)

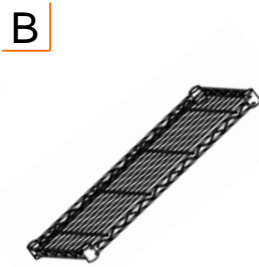

B
MEDIUM SHELF (1)



C
SMALL SHELF (2)

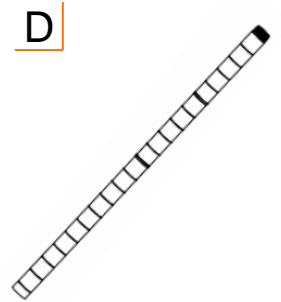

D
TOP POLE (6)
End Cap and Pole Connector
are pre-installed

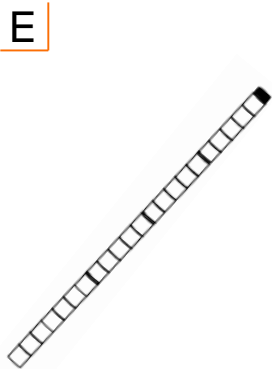

E
MIDDLE POLE (6)
Pole Connector is
pre-installed

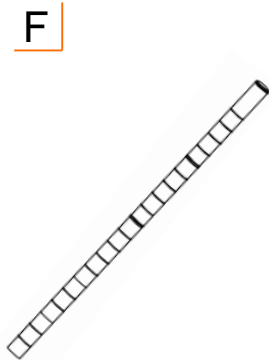

F
BOTTOM POLE (6)



G
HANGING ROD (2)

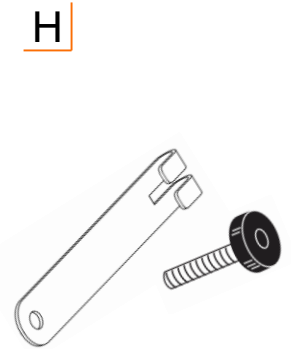

H
**HANGING BRACKET
& SCREW (4)**

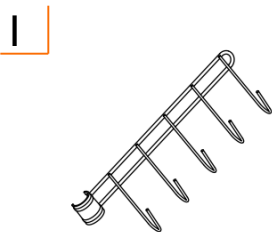

I
**SIDEBAR
W/ HOOKS (1)**

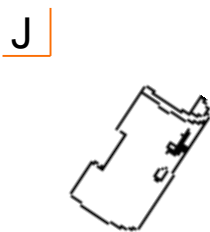

J
**SLIP SLEEVE
(50) + (4) extra**



K
**CASTER
(2) locking, (4) non-locking**

ASSEMBLY INSTRUCTIONS

STEP 1

Screw each CASTER (K) into the bottom of each BOTTOM POLE (F). Turn clockwise to screw in place.

Tighten the CASTER (K) completely using the included Caster Wrench. Failure to do as instructed could result in the caster stem breaking.

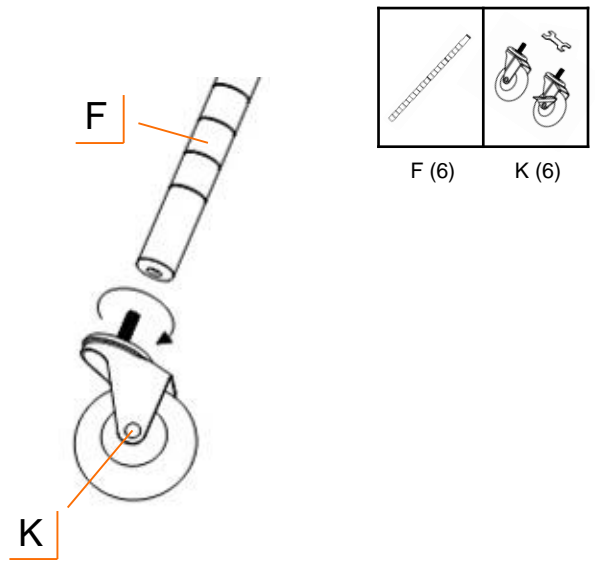

STEP 2

For easiest assembly, do not attach the TOP (D), MIDDLE (E) and BOTTOM (F) POLES until instructed. Once connected, these will be the posts for the Organizer.

Note that each POLE (D+E+F) has slight horizontal line indentations at 1" intervals. Each SLIP SLEEVE (J) has raised horizontal lines inside designed to lock them in place on the POLE (D+E+F).

On all (6) BOTTOM POLES (F) place 1 pair of SLIP SLEEVES (J) at the lowest position, position closest to the CASTERS (K). Please make sure the arrow faces up and that the word "TOP" is right side up.

Slide the pair of SLIP SLEEVES (J) until you hear a click to confirm the pair is locked onto the BOTTOM POLE (F). DO NOT place more than one pair on each POLE (F) at a time.

** Note: There will be a very small gap in-between the SLIP SLEEVES (J)—this is normal.*

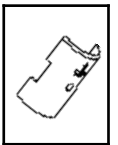

J (12)

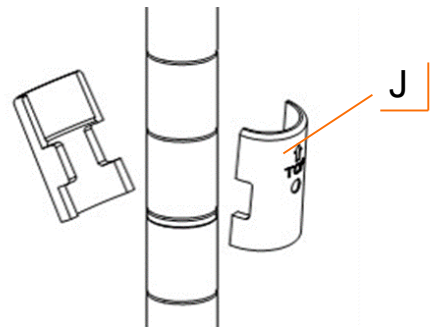

ASSEMBLY INSTRUCTIONS

STEP 3

Place the LARGE SHELF (A) on its side and slide the (6) BOTTOM POLES (F) through the holes in the LARGE SHELF (A). Make sure that the LARGE SHELF (A) corner cylinders are positioned over the SLIP SLEEVES (J).

Stand the unit upright.

**Note: The level side of the LARGE SHELF (A) is the TOP side.*

***Use a rubber mallet, if needed, to secure the LARGE SHELF (A).*

****For convenience, place BOTTOM POLES (F) with Locking Casters on the long side of the shelf if the organizer will be pushed against a wall OR if the organizer is frequently rolled around like a cart, place BOTTOM POLES (F) with Locking Casters on the side being pushed or pulled.*

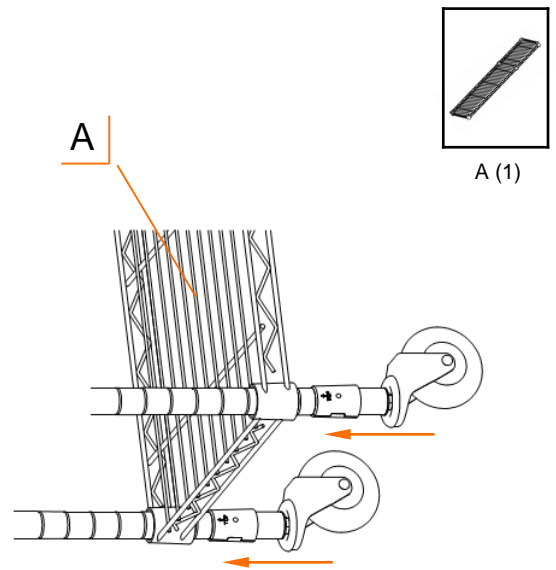

STEP 4

Screw the MIDDLE POLES (E) into the BOTTOM POLES (F).

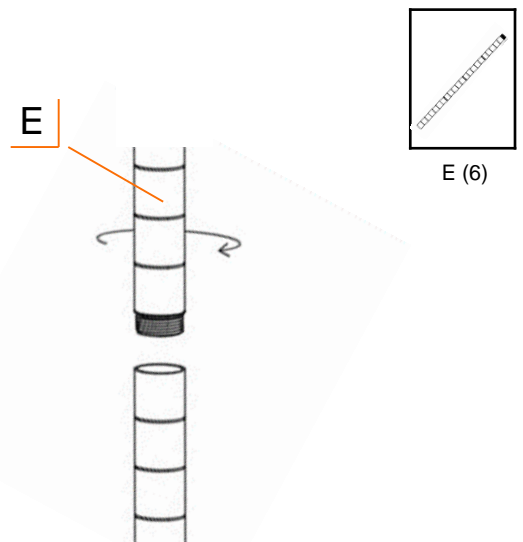

ASSEMBLY INSTRUCTIONS

STEP 5

Screw the TOP POLES (D) into the MIDDLE POLES (E).

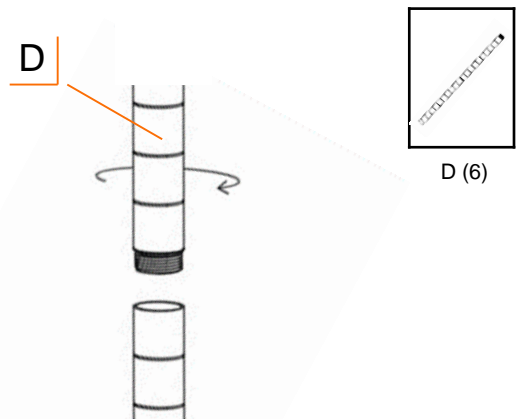

STEP 6

Decide the position of MEDIUM SHELF (B) and SMALL SHELVES (C) that will best fit your needs.

Starting with the lowest desired SHELF position, Place 1 pair of SLIP SLEEVES (J) on each of the (4) POLES for that SHELF. Please make sure the arrow faces up and that the word "TOP" is right side up. Make sure that the heights are identical for each POLE.

Repeat Step 6 to install the next lowest SHELF as desired.

If you are installing the MEDIUM SHELF (B) above the SMALL SHELF (C), please make sure that you place the SLIP SLEEVES (J) at least 4 indentations above the SMALL SHELF (C) so that the HANGING BAR (G+H) can fit properly.

**Use a rubber mallet, if needed, to secure the SHELVES (A+B+C).*

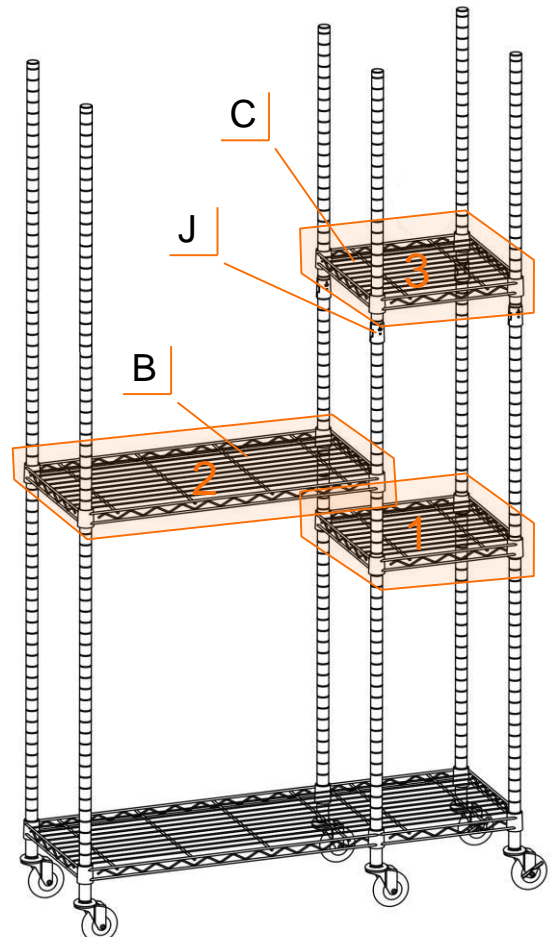
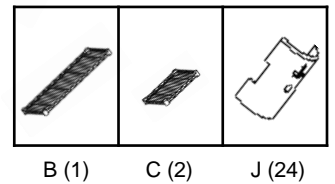

ASSEMBLY INSTRUCTIONS

STEP 7

Place 1 pair of SLIP SLEEVES (J) at the top of each POLE. Please make sure the arrow faces up and that the word "TOP" is right side up.

Lower LARGE SHELF (A) over the POLES so that the corner cylinders of the LARGE SHELF (A) are positioned over the SLIP SLEEVES (J).

**Use a rubber mallet, if needed, to secure the SHELVES (A+B+C).*

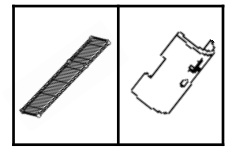

A (1) J (12)

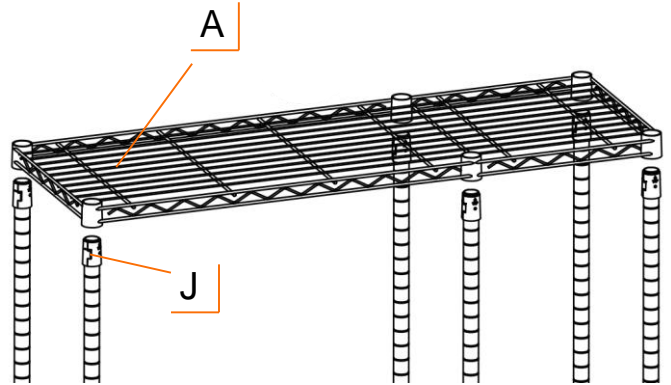

STEP 8

Hang the HANGING BRACKET (H) on both ends of the MEDIUM SHELF (B) and the LARGE SHELF (A) as shown.

Fasten HANGING SCREW (H) through HANGING BRACKET (H) to HANGING ROD (G). Do this for both HANGING RODS (G).

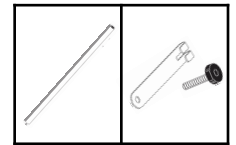

G (2) H (4)

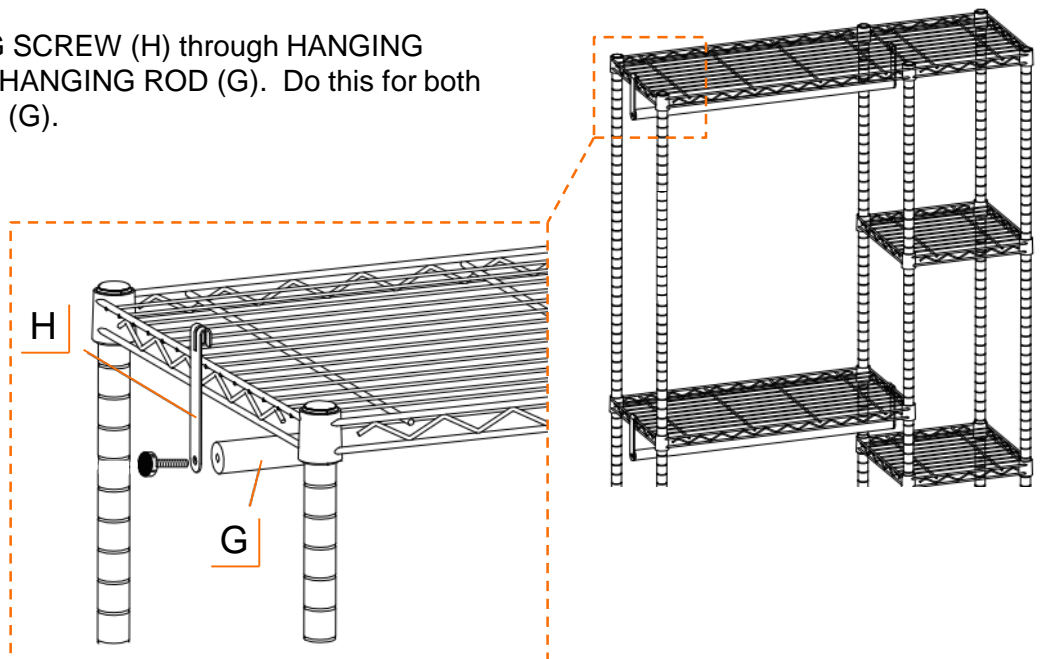

ASSEMBLY INSTRUCTIONS

STEP 9

Locate the desired position and place a pair SLIP SLEEVES (J) onto the pole.

Slide the SIDEBAR W/ HOOKS (I) down, over the SLIP SLEEVES (J).

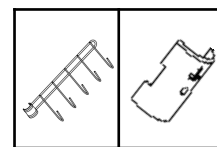

I (1)

J (2)

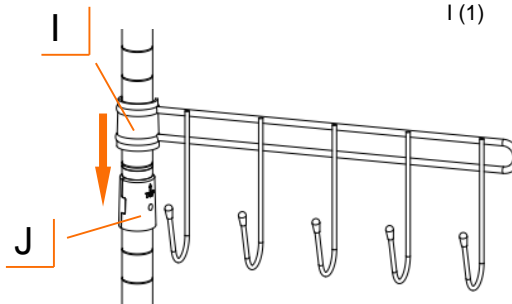

SERVICE PARTS LIST – Bronze Color

Our Customer Service provides the following replacement parts:

Description

- | | |
|-----------------------|----------------------|
| 1) Slip Sleeve | 9) Wrench |
| 2) Top Pole | 10) Medium Shelf |
| 3) Pole Connector | 11) Sidebar w/ Hooks |
| 4) Middle Pole | 12) Hanging Rod |
| 5) Small Shelf | 13) Hanger Screw |
| 6) Bottom Pole | 14) Hanger |
| 7) Locking Caster | 15) Large Shelf |
| 8) Non-locking Caster | |

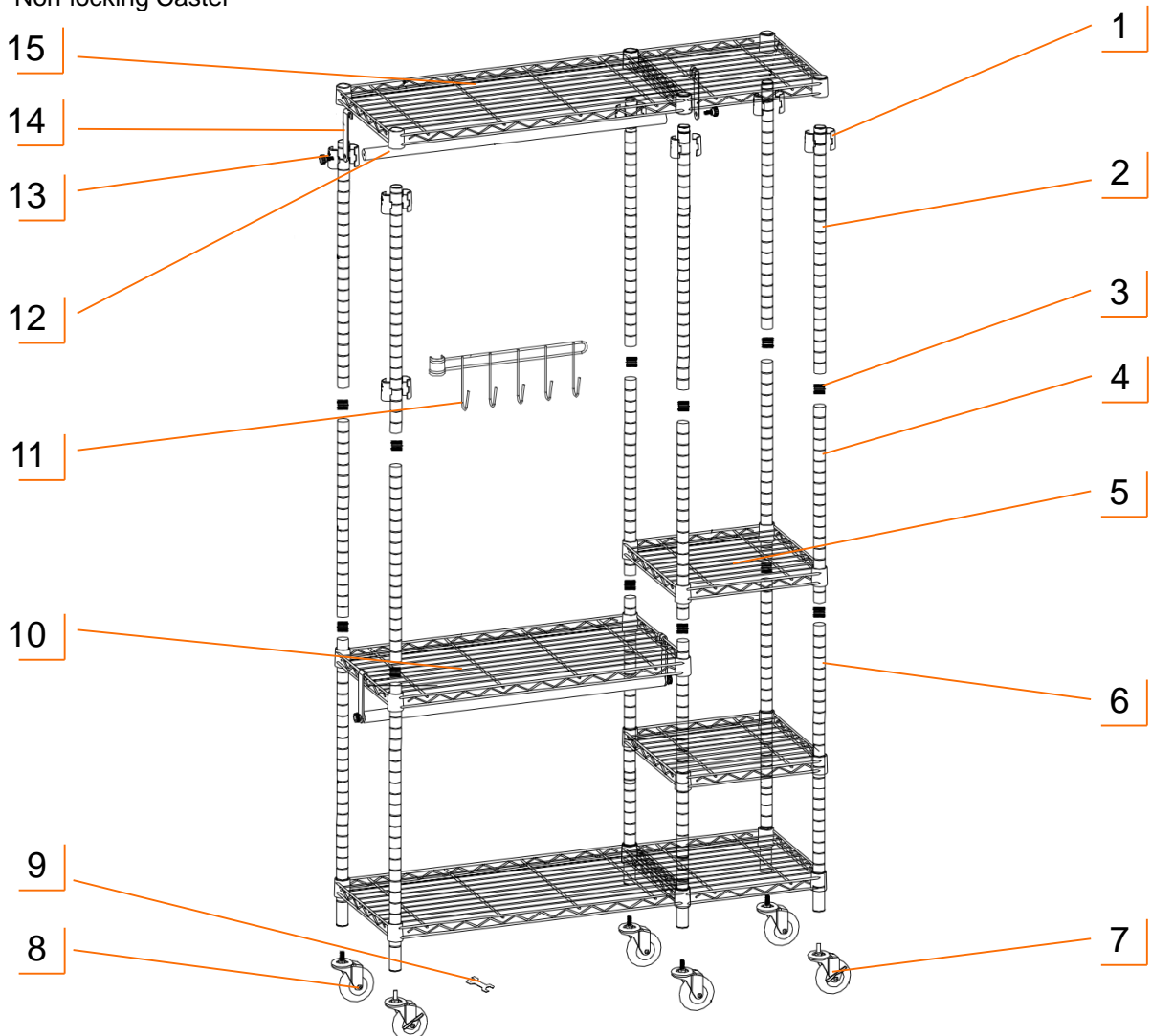

SERVICE PARTS LIST – Chrome Color

Our Customer Service provides the following replacement parts:

Description

- | | |
|-----------------------|----------------------|
| 1) Slip Sleeve | 9) Wrench |
| 2) Top Pole | 10) Medium Shelf |
| 3) Pole Connector | 11) Sidebar w/ Hooks |
| 4) Middle Pole | 12) Hanging Rod |
| 5) Small Shelf | 13) Hanger Screw |
| 6) Bottom Pole | 13) Hanger |
| 7) Locking Caster | 14) Large Shelf |
| 8) Non-locking Caster | |

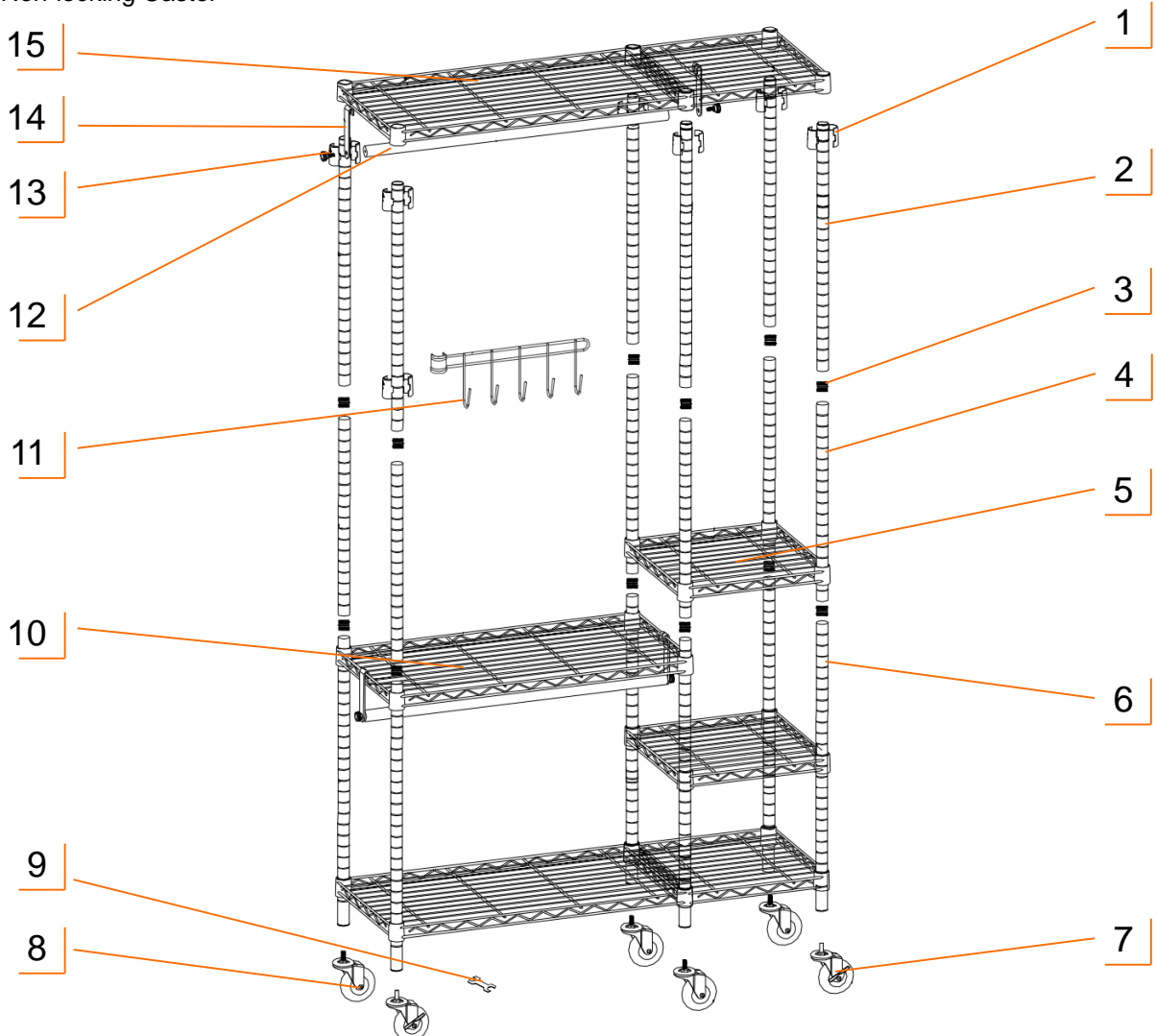

WARNINGS

- 1. Read and understand all instructions.** Failure to follow all instructions may result in injury and/or damage.
- 2. Use the provided caster wrench to tighten casters completely.** Failure to do as instructed could result in the caster stem breaking thereby causing the shelving rack to collapse.
- 3. The warnings, cautions, and instructions discussed in this manual cannot cover all possible conditions or situations that may occur.** The user must always be aware of their environment and ensure that they use the product in a safe and responsible manner.
- 4. Do NOT modify the product in any way.** Unauthorized modification may impair the function and/or safety of the product, and may affect the life of the product.
- 5. Check for damaged parts.** Before using this product, carefully check that all parts are in good condition, and that the product will operate properly and perform its intended function. Check for damaged parts and any other conditions that may affect the operation of this product. Replace damaged or worn parts, and never use this product with a damaged part.
- 6. Do NOT overload the product.**

Weight capacity per small shelf	25 lb
Weight capacity per medium shelf	40 lb
Weight capacity per large shelf	60 lb
Weight capacity per hanging rod	40 lb
Weight capacity per side bar	10 lb
Total weight capacity per organizer	300 lb

CARE AND MAINTENANCE

- Avoid harsh, abrasive cleaners, and other corrosive chemicals.

PRODUCT REGISTRATION

Thank you for purchasing a Mobile Closet Organizer. In order to register your product and receive streamlined customer service, please fill out the following Product Registration Form and (1) fax the form (2) complete the Product Registration Form online or (3) scan and email the form. Include a copy of your original receipt with your submission.

First Name: _____ Last Name: _____

Address: _____

City: _____ State: _____ Zip Code: _____

Email Address: _____ Phone: _____

Product Model #: _____ Purchase Date: ____ / ____ / ____

Location of Purchase: _____

Please rate the importance of each feature (1=least important; 10=most important)

Quality ____ Price ____ Size/Capacity ____ Appearance ____ Other ____

How did you hear about our product?

- Magazine Ad Catalog Salesperson Word of Mouth
 Internet Store Display Other

Marital Status: Single Married

Household Income: Below \$50,000 \$50,000-\$150,000 \$150,000+

Education: High School College Graduate School

Primary Residence: Own Rent

Comments/Suggestions:



1 YEAR LIMITED WARRANTY

Mobile Closet Organizer

We warrant to the original consumer purchaser (“Purchaser”) of the Mobile Closet Organizer (“Product”) that each Product shall be free from defects in workmanship and materials for a period of 1 year from the date of original purchase. Our obligation under this warranty shall be limited to repair or replacement of, or adequate compensation for the Product which shall not be greater than the amount of the purchase price of the Product, at the option of us, during the warranty period. All replaced parts and Products become the property of us and must be returned to us.

This warranty excludes normal wear and tear of the Product and its parts or components, and damage arising from any of the following: negligent use or misuse of the Product, use contrary to this User’s Manual, or alteration by any one other than us. The warranty period of 1 year shall not be extended or renewed by the repair or replacement of, or compensation for, the Product. Any warranty implied by applicable law is limited in duration to one year from the date of purchase and is subject to the same conditions and limitations as is provided for our express warranty.

Except as set forth herein, and to the extent of applicable there are no warranties on this Product either express or implied, and we disclaim all warranties including, but not limited to, any implied warranties of merchantability, infringement or fitness for a particular purpose. No warranty or guarantee given by any person, firm, or corporation with respect to this product shall be binding on us.

If your Product is defective or otherwise requires service or parts, please call our Customer Service toll-free. Please tell us which model you purchased, the date of the purchase, and the problem with your Product. A copy of your original purchase receipt must accompany your service request.

LIMITATION OF REMEDIES AND LIABILITY

We (and its employees, officers, members, managers, affiliates an assigns) shall not be liable for any incidental, consequential, special, indirect, remote, special or punitive damages for breach of any warranty, express or implied, including, but not limited to, lost profits, lost savings, loss of anticipated benefits and attorneys’ fees, which arise out of the purchase, use or inability to use the Product, whether arising out of contract, negligence, strict tort, product liability, or any other legal theory on which a claim is based. As noted above, to the extent damages are allowed by our express warranty or by applicable law, those damages may not exceed the purchase price paid for the Product. Without limiting the foregoing Purchaser assumes all risk and liability for loss, damage or injury to Purchaser and Purchaser’s property and to others and their property arising out of the use, misuse, or inability to use this Product. This limited warranty shall not extend to anyone other than the original purchaser of this product, is nontransferable and states your exclusive remedy.

Some states do not allow the exclusion or limitation of incidental, consequential, special, or punitive damages, so the above limitation or exclusion may not apply to you. The above warranty gives you specific legal rights, and you may have other rights which vary from state to state.

CONTACT US

QUESTIONS? NEED PARTS? WE ARE HERE TO HELP!

Please feel free to contact us. There are no questions too small, or any problems too big. We're committed to providing our customers with the highest level of service.