

# **INSTALLATION**

## *Product Manual*

Version: 510043US-00-26A

# Installation Instructions

---

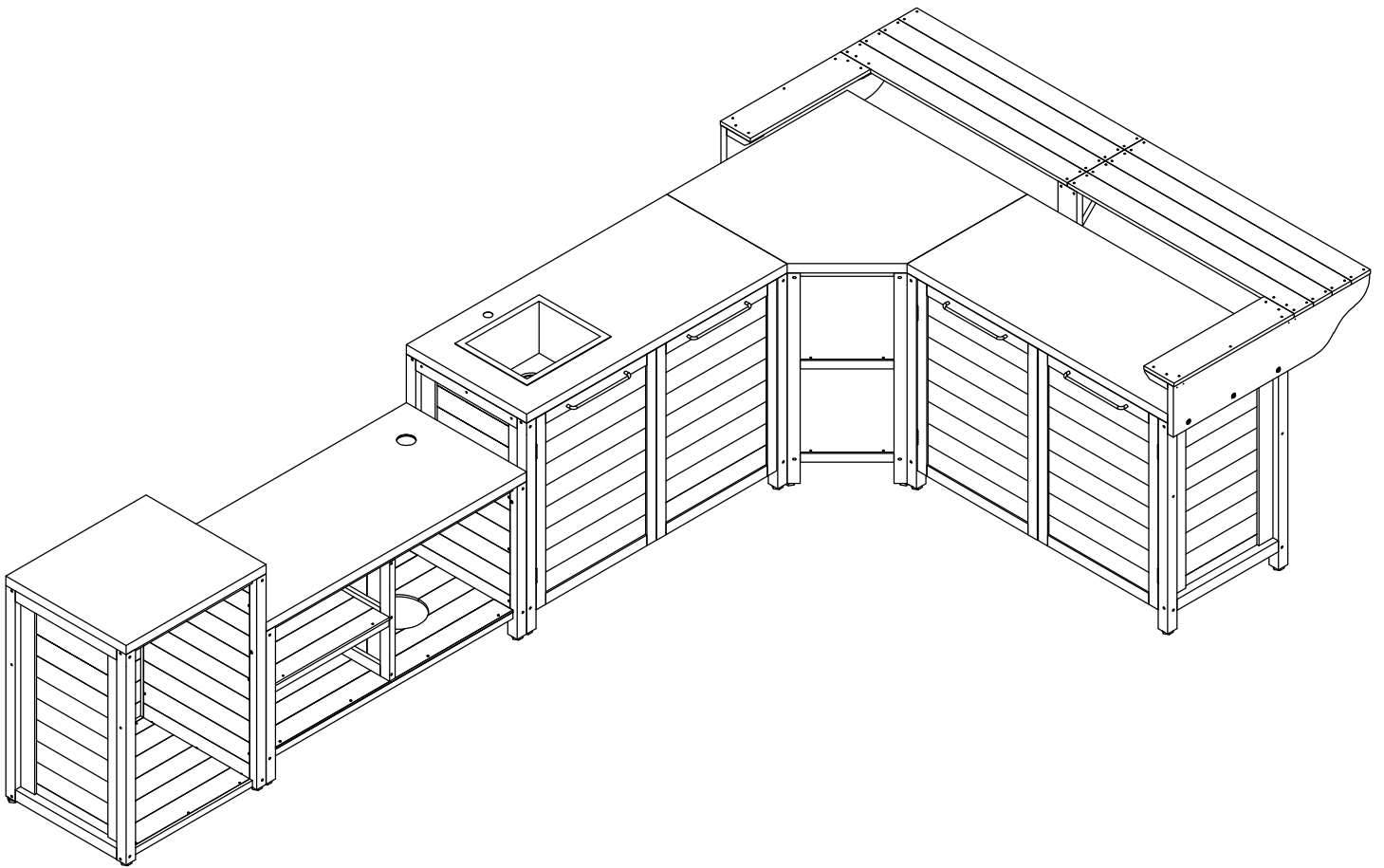

# Installation Instructions

---

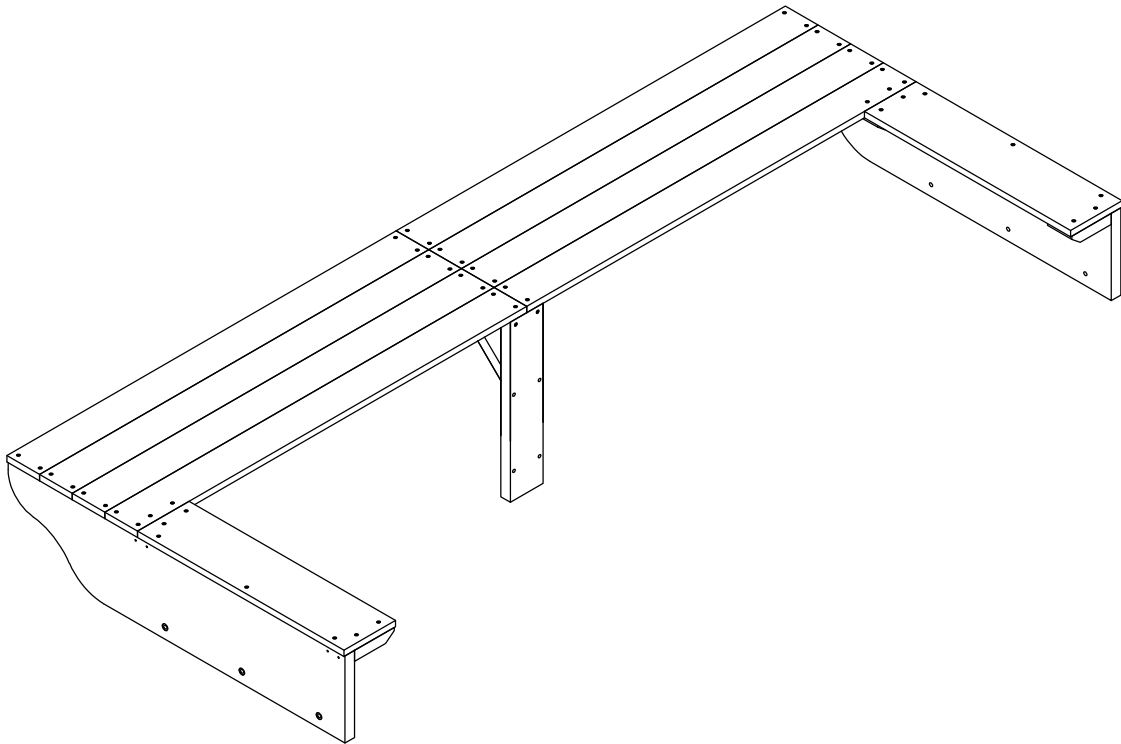

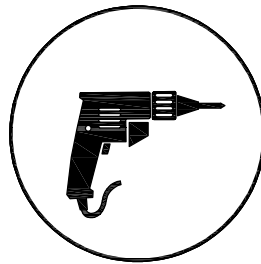
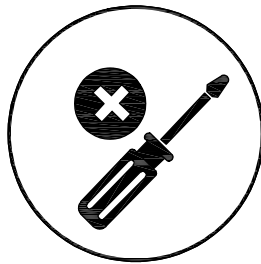
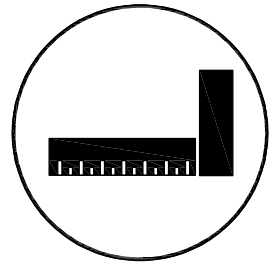
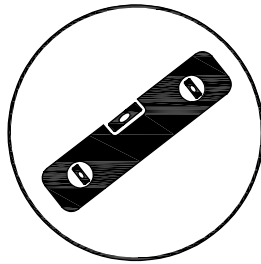
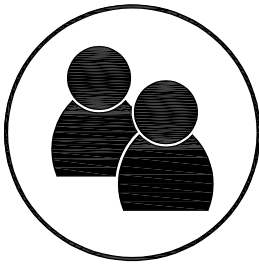
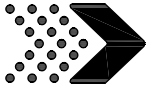

Icons and their uses you will see throughout this manual

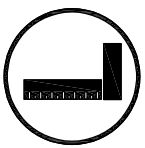

You will need to make sure that your assembly is square before tightening your bolts.

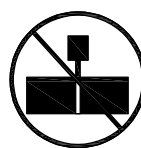

This icon warns you to not over tighten your bolts. This is to prevent structural damage and also splintering your wood.



For proper assembly you will need to ensure that your structure is level before proceeding to the next step.



This icon will show you what drill attachments are needed. For this example you will need a Phillips head attachment .

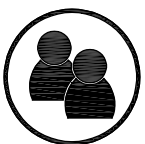

Some steps in the assembly process will require an extra set of hands. Make sure you have a helper available.



This size of the open-end wrench on these icons should correspond to the size of the nut.

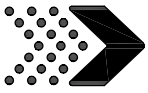

Wood Components (Not to Scale)

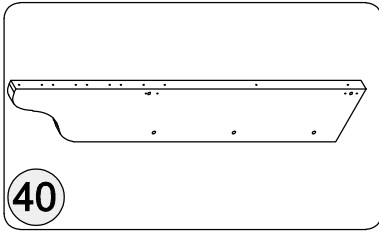

40

left side

Qty: 1

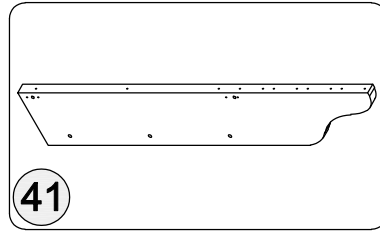

41

right side

Qty: 1

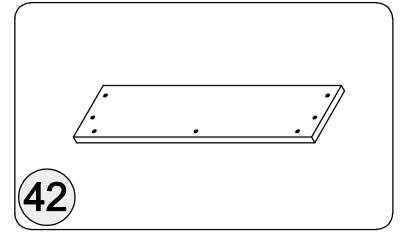

42

Side countertop

Qty: 2

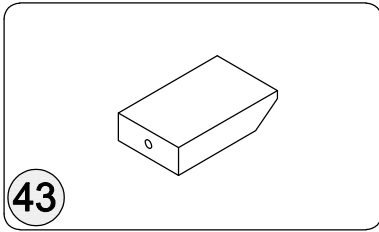

43

Support block

Qty: 4

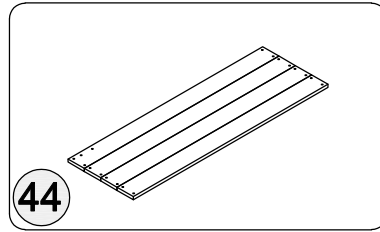

44

Left countertop

Qty: 1

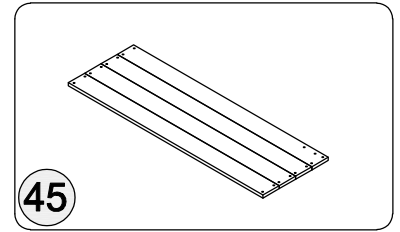

45

Right countertop

Qty: 1

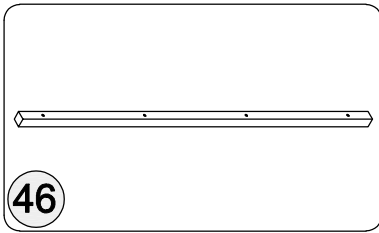

46

preceding article

Qty: 2

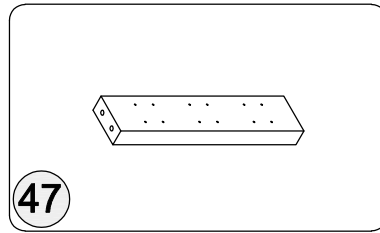

47

Horizontal beam

Qty: 1

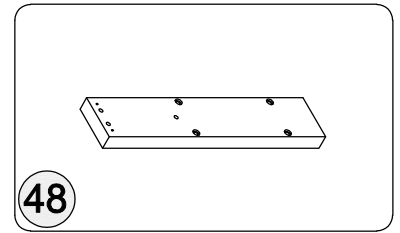

48

Vertical wood

Qty: 1

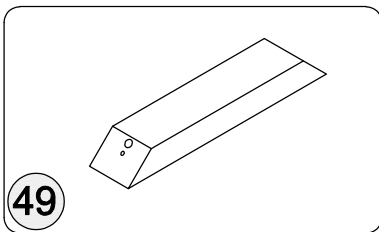

49

Slant wood

Qty: 1

Hardware Components

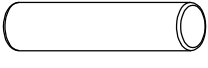
	
Ø8*30	
<b>(A)</b>	<b>X 8</b>

Wooden tenons

	
M4*60	
<b>(F)</b>	<b>X 10</b>

Screw

	
M4*35	
<b>(M)</b>	<b>X 52</b>

Screw

	
M4*40	
<b>(N)</b>	<b>X 8</b>

Screw

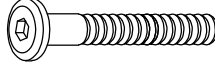
	
M8*80	
<b>(O)</b>	<b>X 6</b>

screws

	
Ø21/Ø8	
<b>(Q)</b>	<b>X 6</b>

Flat washer

	
M6	
<b>(S)</b>	<b>X 1</b>

screwdriver

	
M8	
<b>(T)</b>	<b>X 1</b>

screwdriver

	
M6*45	
<b>(Z)</b>	<b>X 4</b>

screws

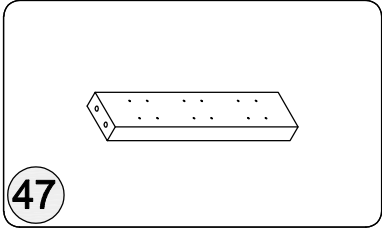

**47**  
Horizontal beam  
Qty: 1

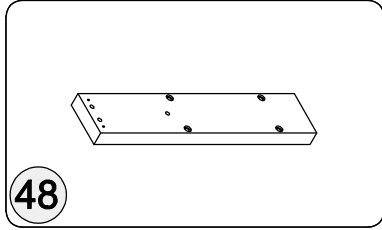

**48**  
Vertical wood  
Qty: 1

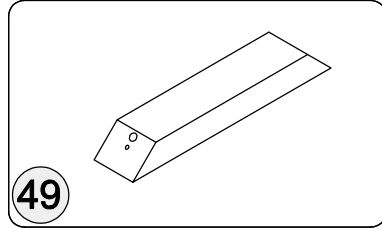

**49**  
Slant wood  
Qty: 1

1. Connect with hardware A first, then install with hardware M, F

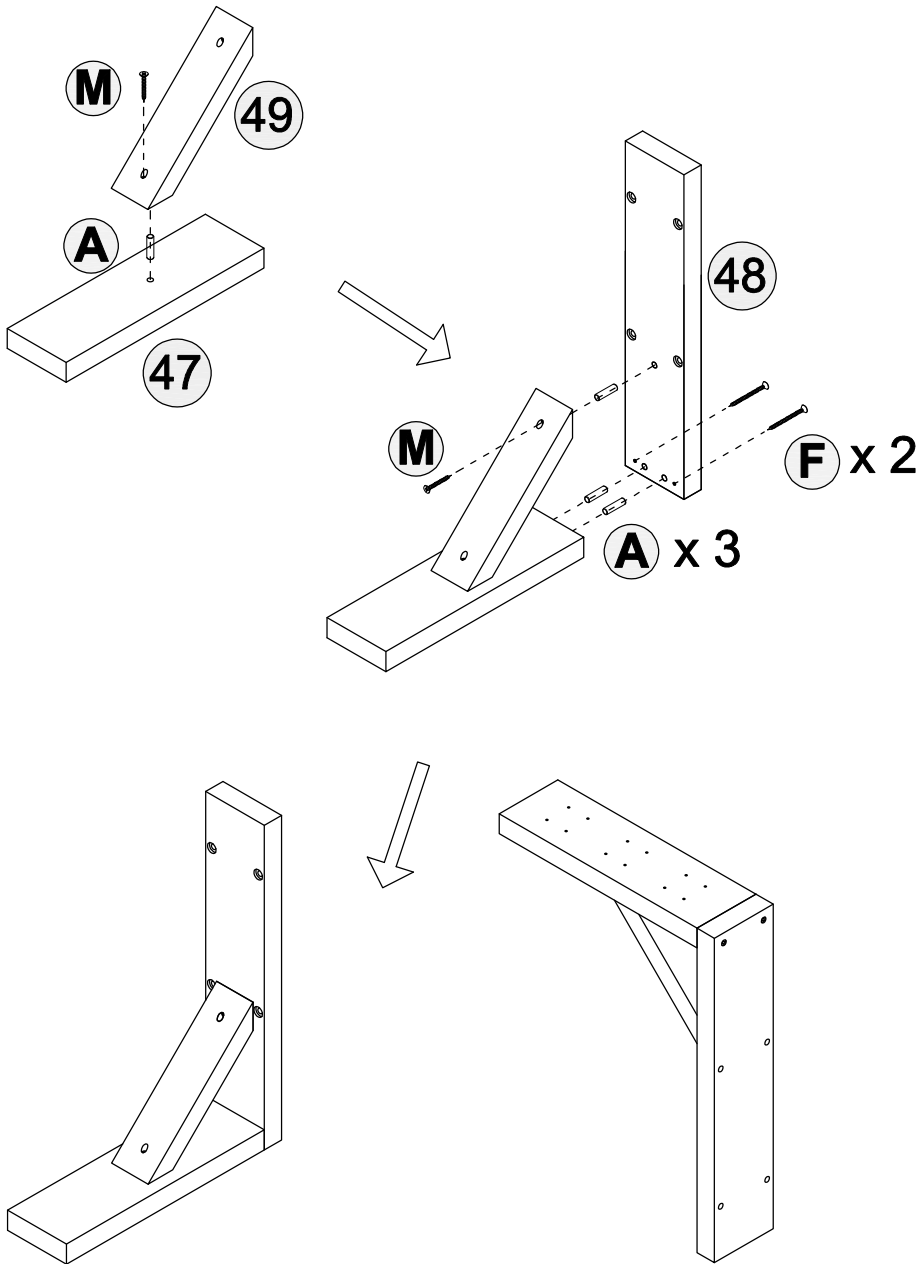

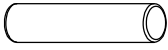
	
Ø8*30	
<b>A</b>	<b>x 4</b>

	
M4*35	
<b>M</b>	<b>x 2</b>

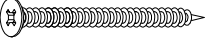
	
M4*60	
<b>F</b>	<b>x 2</b>

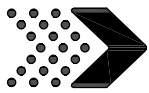

# Installation of support blocks

Step 2

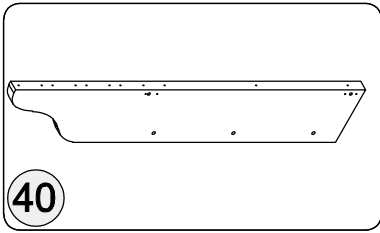

left side

Qty: 1

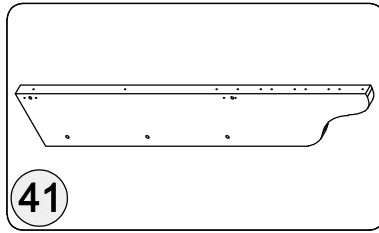

right side

Qty: 1

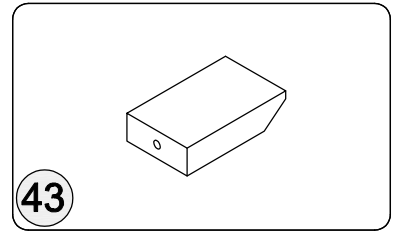

Support block

Qty: 4

1. Connect with hardware A first, then install with hardware F

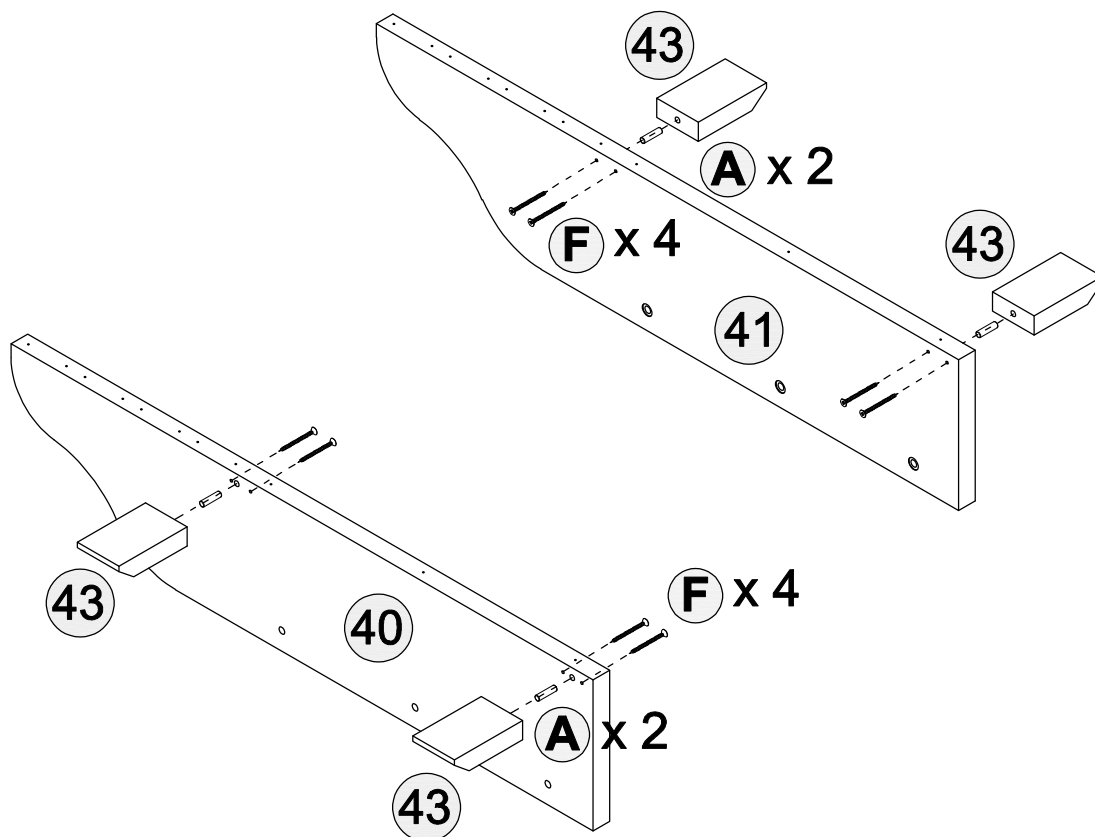
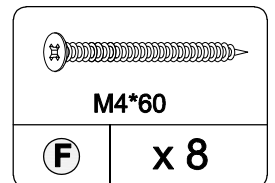
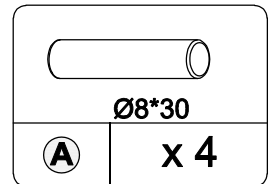

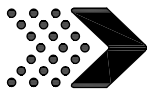

# Side panel installation

## Step 3

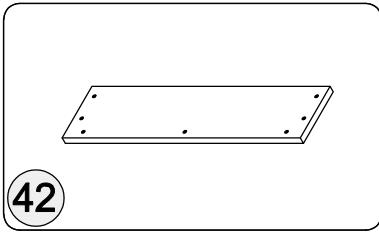

Side countertop  
Qty: 2

	
M4*35	
<b>M</b>	x 14

1. Pre-install the hardware M for the pilot hole, and then install the other holes of the hardware M.

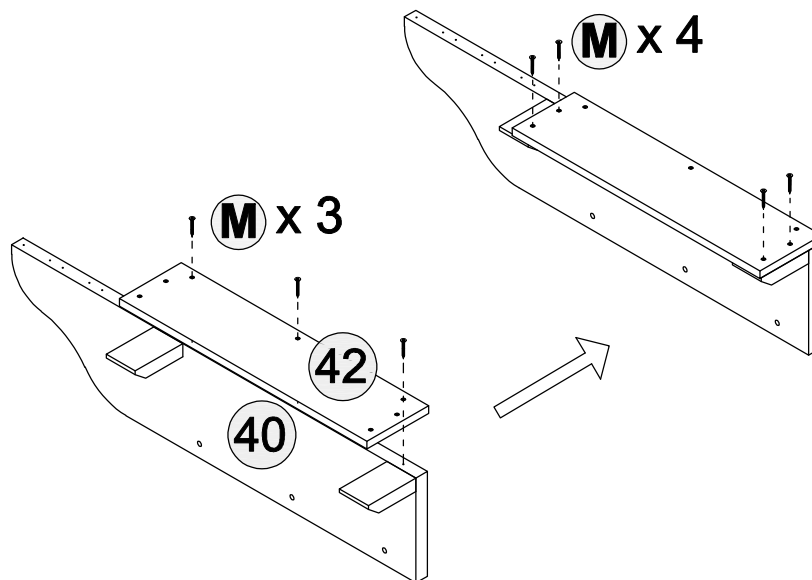
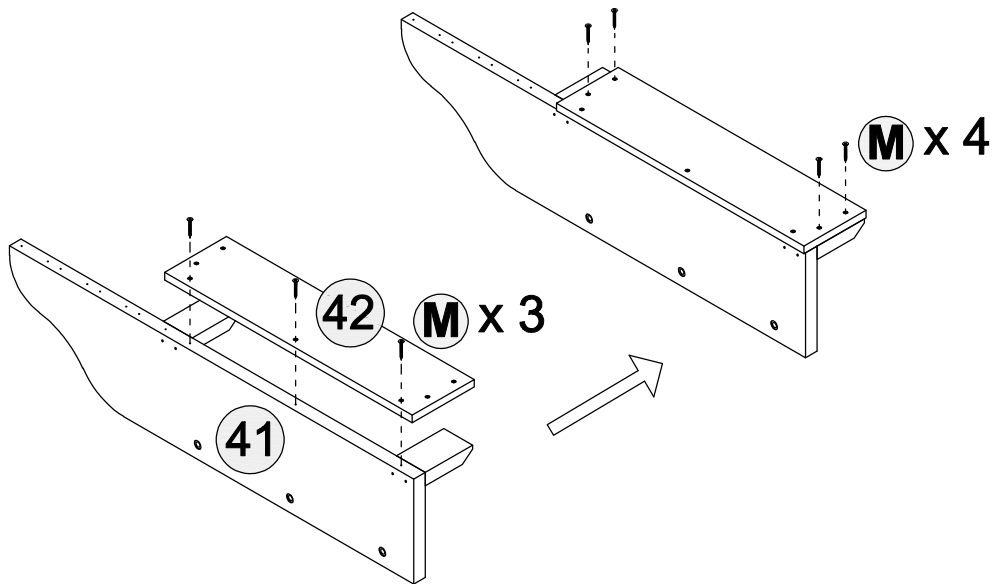

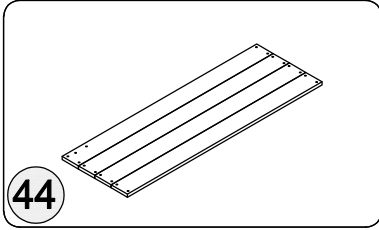
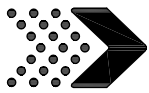

44

Left countertop  
Qty: 1

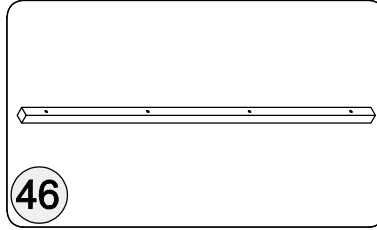

46

preceding article  
Qty: 1

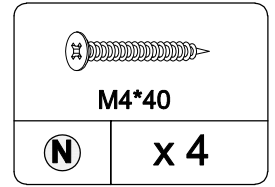

M4\*40

N

x 4

1. Use hardware N to pass through component 46 and install it towards the lead hole

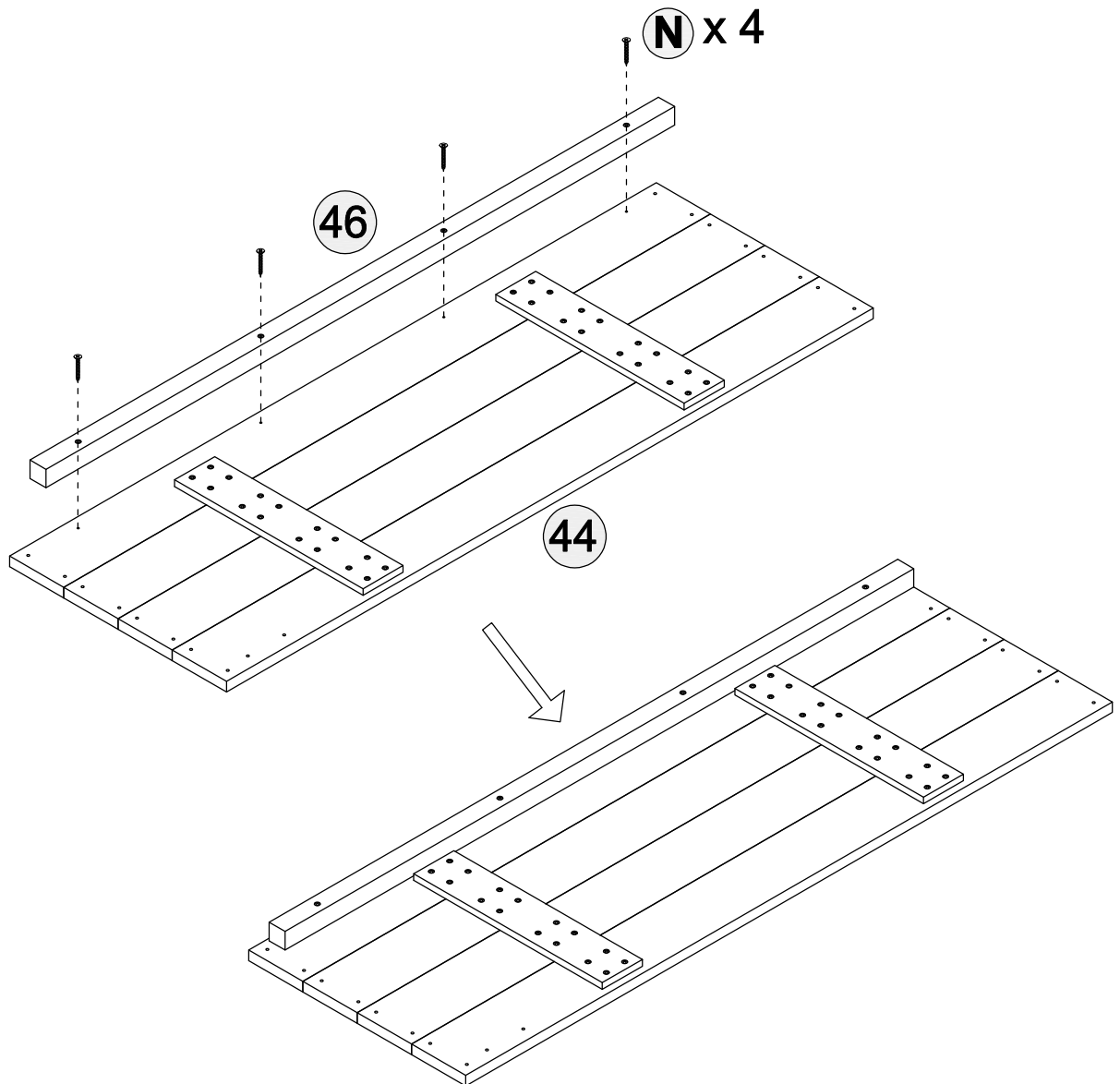

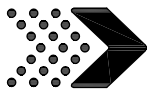

1. A

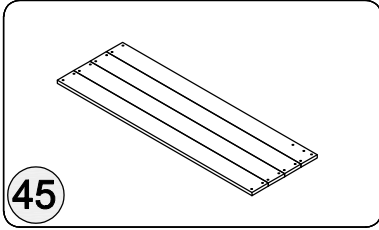

**45**  
Right countertop  
Qty: 1

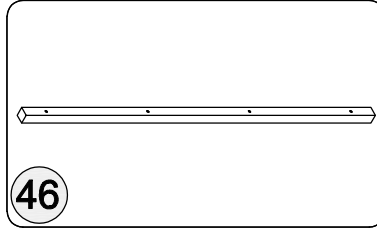

**46**  
preceding article  
Qty: 1

M4*40	
<b>N</b>	<b>x 4</b>

1. Use hardware N to pass through component 46 and install it towards the lead hole

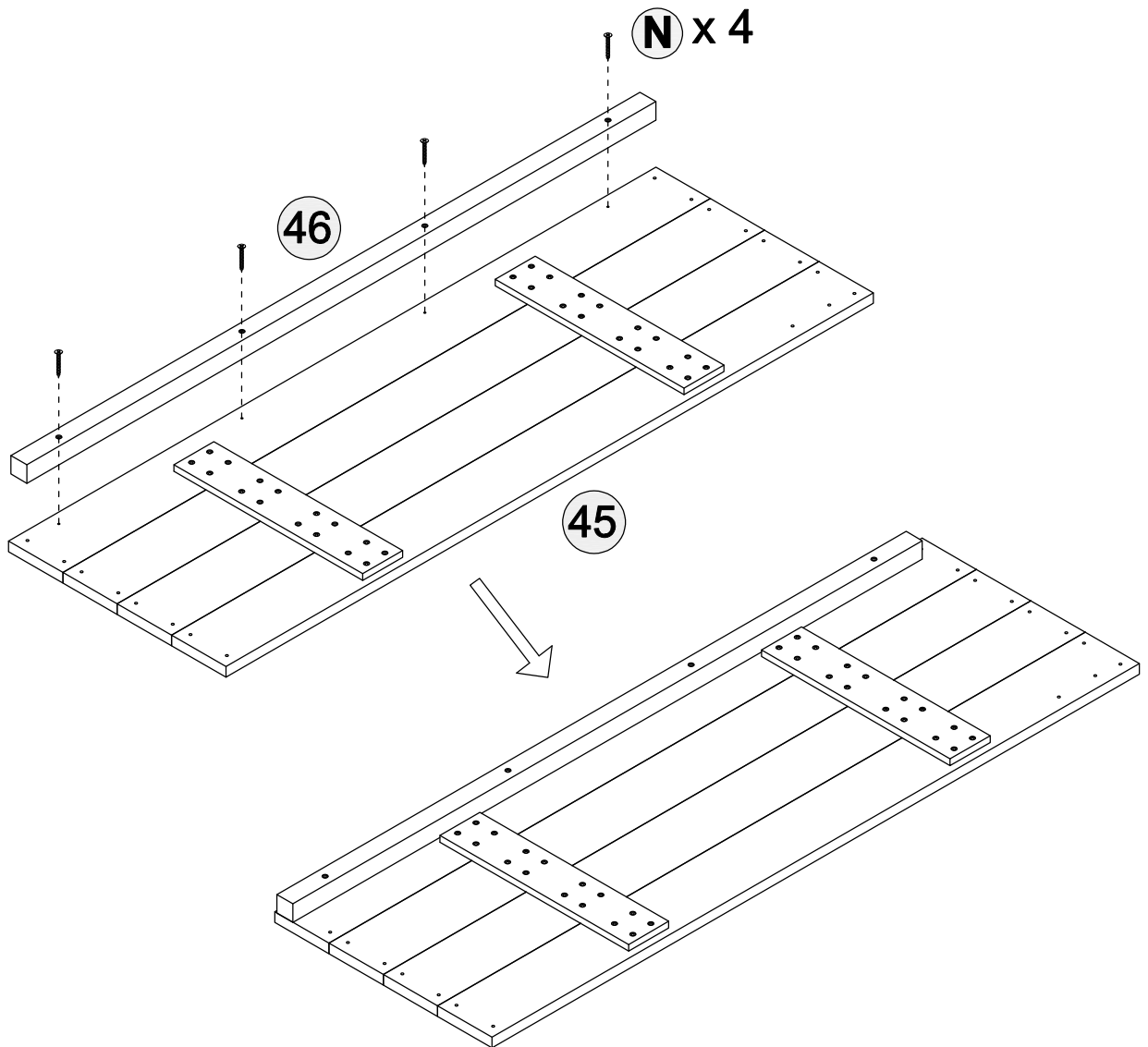

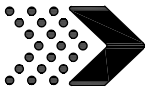

1. Use tool S to install hardware Z



M6\*45

**Z**

x 4

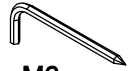

M6

**S**

x 1

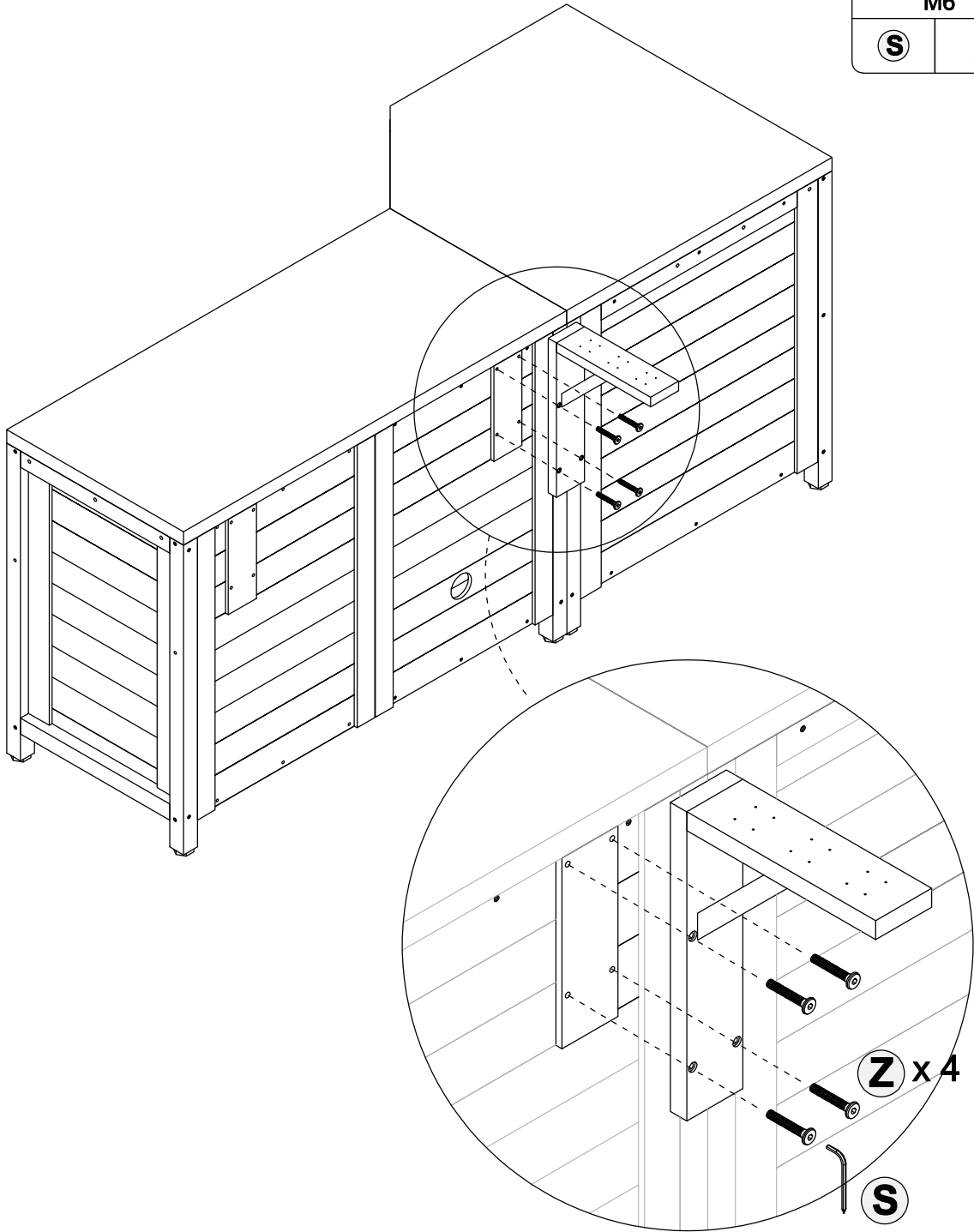

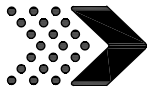

# Installation on both sides

## Step 7

1. Thread hardware O through hardware Q, and then use tool hardware T to install component
2. The installation method on both sides is the same

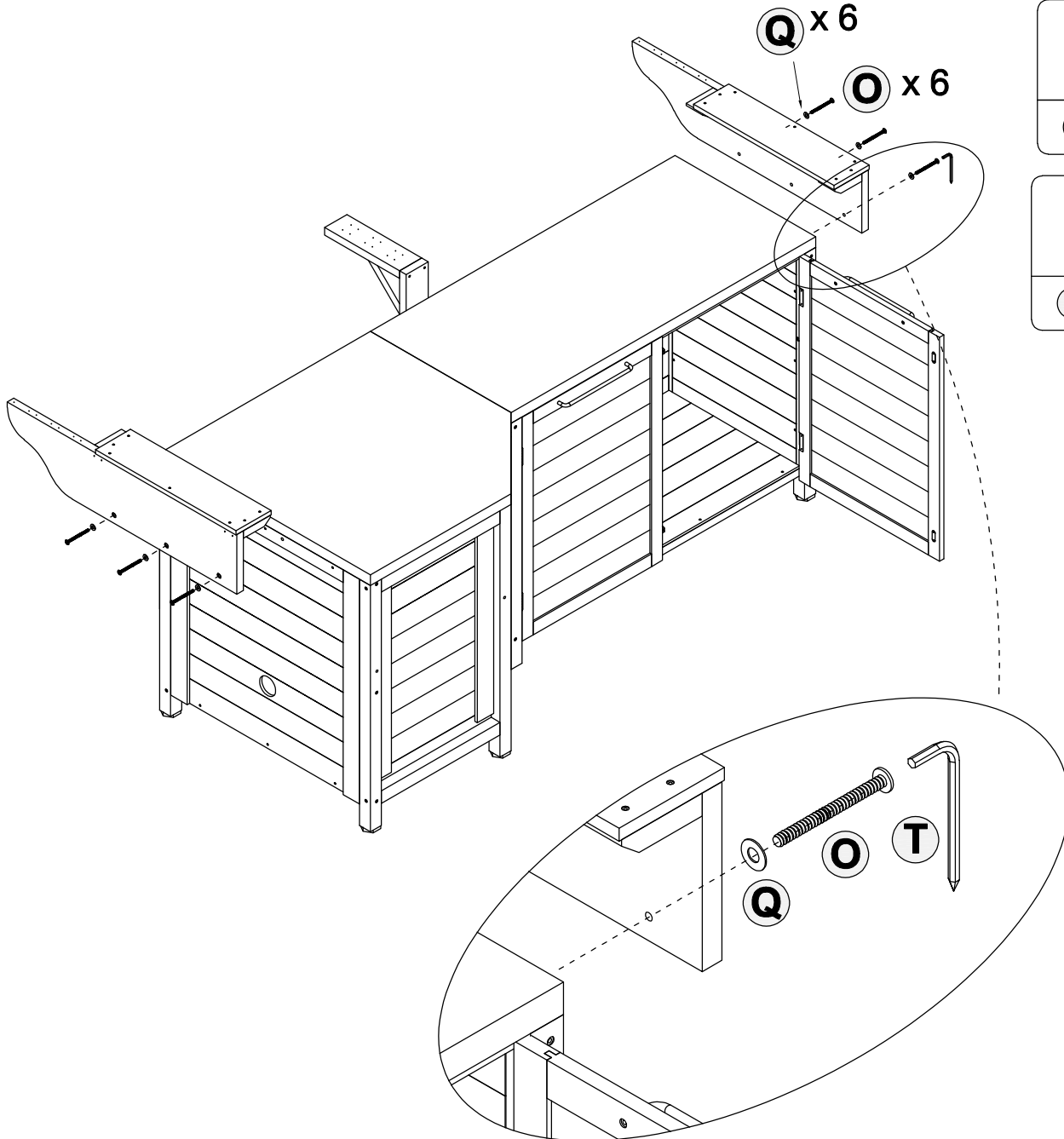

	M8*80
	x 6

	Ø21/Ø8
	x 6

	M8
	x 1

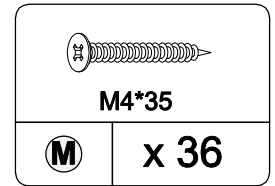
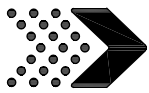

1. Pre-install the hardware M for the pilot hole, and then install the other holes of the hardware M.

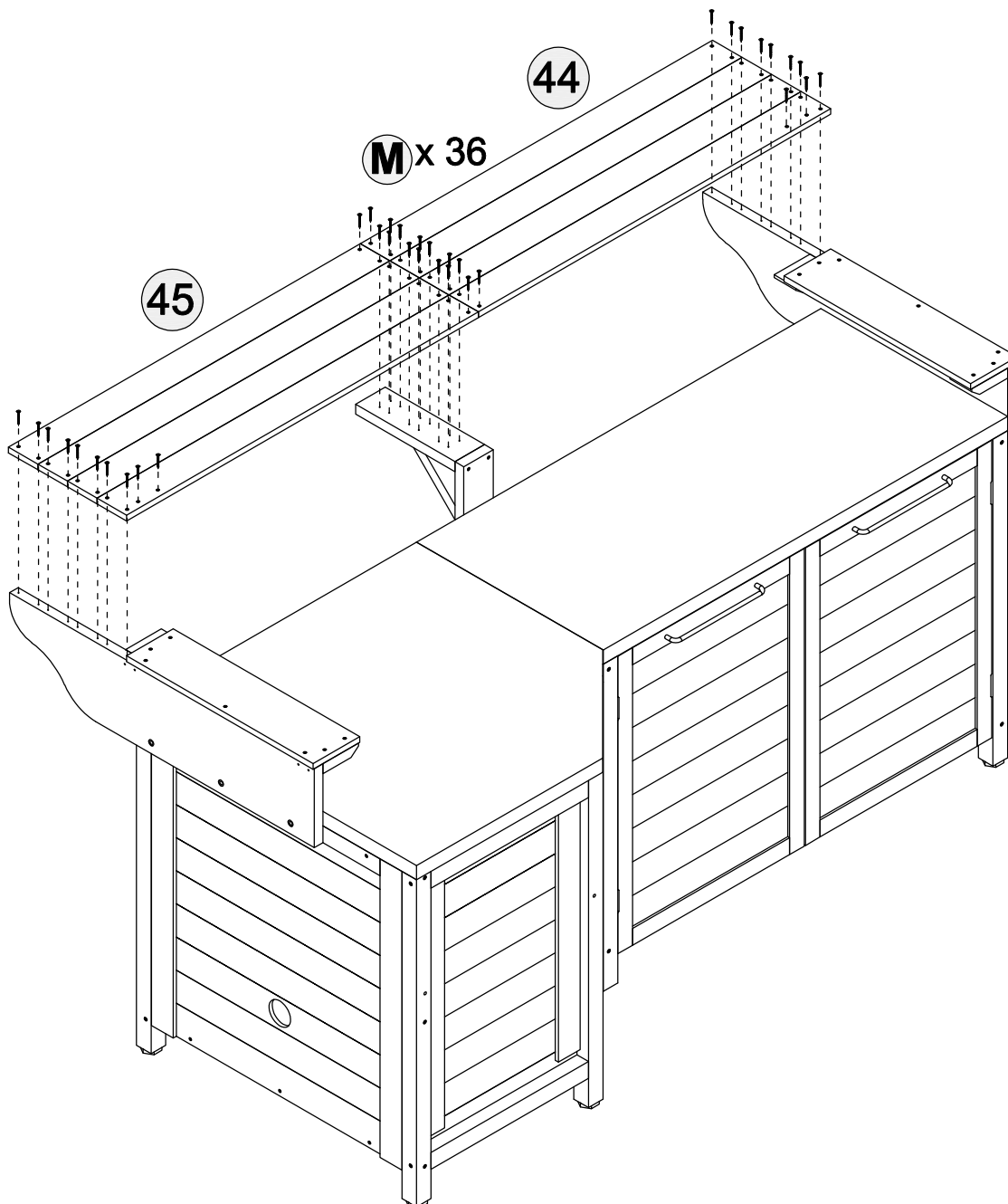

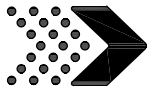

Installation completed

Step 9

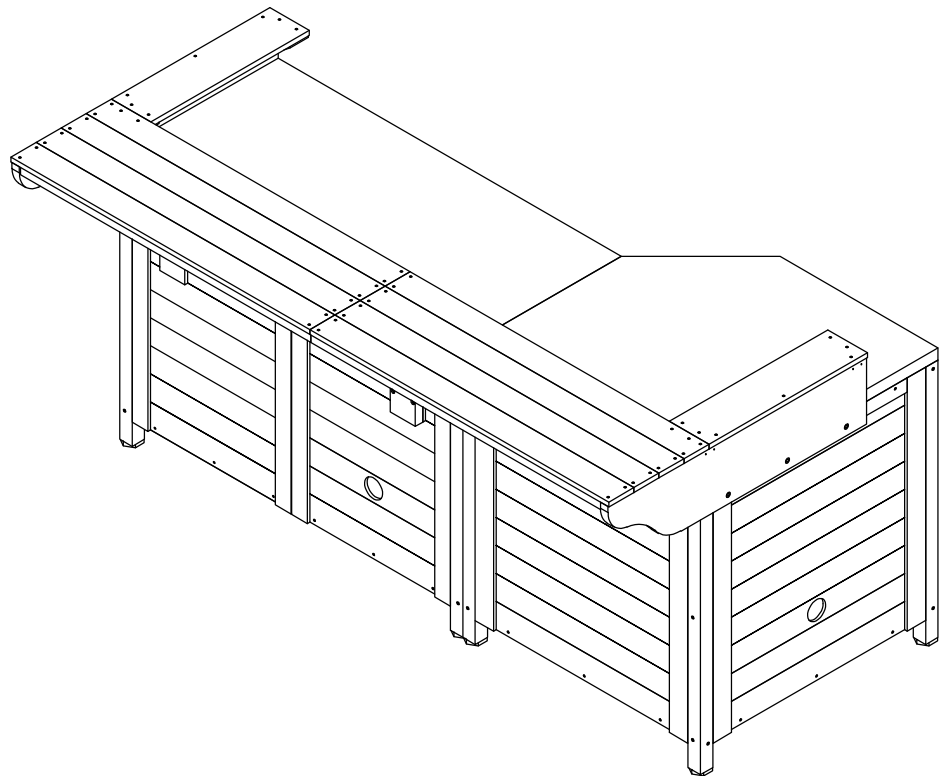
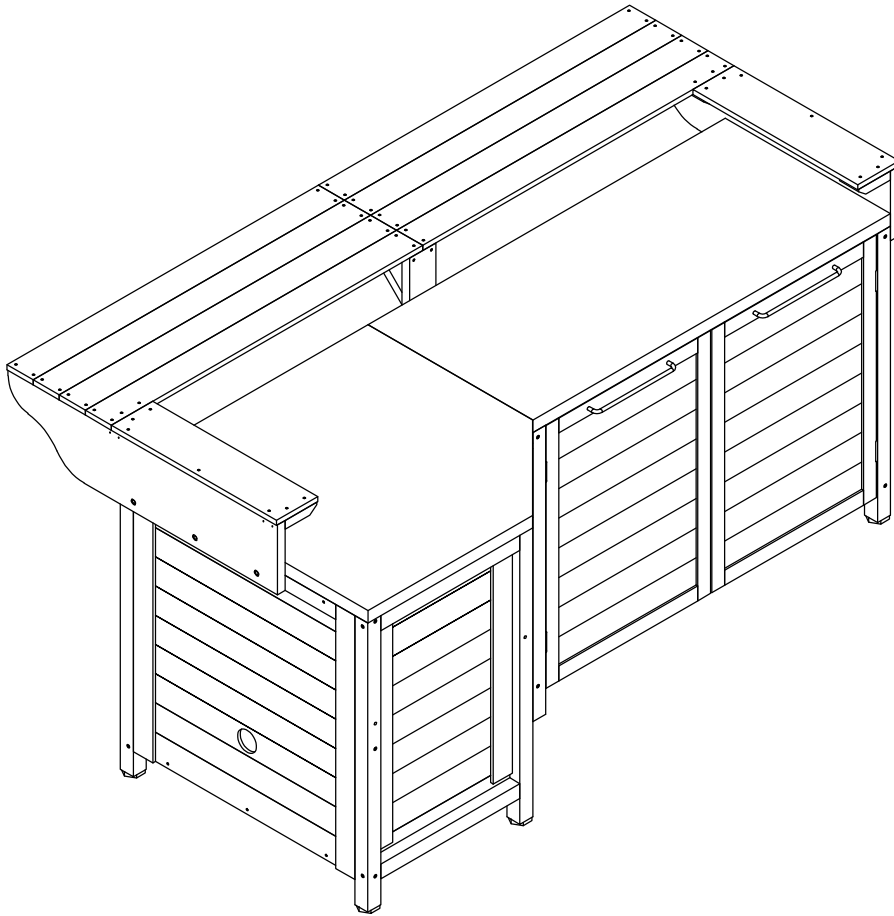

# WARRANTY

## WARRANTY CLAIMS

- There is a 30-day warranty for broken furniture or any other problems that do not work properly. The warranty will start from the date of purchase which must be verified by proof of purchase.
- Before making a claim, we may be able to answer your query, simply call us. Please leave your purchase order number, along with some details of the problem, if you want a replacement part. We will arrange within 48 hours. If there is out of stock, we will reply with a shipping date.
- The product must be used in accordance with the instructions provided. For health reasons.
- For other reasons, if the furniture needs to be returned, it must be cleaned and dried and operated within 30 days of receipt.

## Type of Warranty Claim

- Failure to follow the furniture instructions will invalidate the warranty. Attention please.
- Does not include damage during installation, but includes damage during transportation.

## Scope of responsibility

- Shall not bear any responsibility for misuse or user damage and / or loss of parts during the installation of furniture.
- After using, the damage and scratches of the furniture are not covered by the warranty.

## The Warranty Relates to All Bought in The Us and Covers The Following Areas

- Sheet parts: 1 month from the date of purchase.
- Electrical parts: 1 month from the date of purchase.

# RETURNS

## CHANGED YOUR MIND AND NEED TO RETURN YOU ITEM?

### PLEASE FOLLOW THE BELOW INSTRUCTIONS:

- If you have purchased and have simply changed your mind, follow the retailer's instructions for returns.

### DEFECTIVE ITEMS

- If your item is defective in any way, i.e. it doesn't work but you can't identify why, in the first instance, please call us.

### DAMAGED ITEMS

- If you receive an order with obvious shipping damage from the retailer, then we suggest the delivery is refused. If the delivery has been accepted and then shipping damage is found, please follow the specific instructions advised by the retailer.  
In all circumstances please save all packaging material and paperwork for the order. Please be aware that if you dispose of packaging material or attempt to return the merchandise without contacting the fulfiller, you jeopardise your chances of making a claim, and you may not receive a credit for the return.

### AFTER-SALES CONTACT



adelahu@fufugaga.com



208-820-0068  
208-820-0799