

ASSEMBLY INSTRUCTIONS

Item #: Hadley Sofa

Please identify and locate all assembly parts (see parts list) before discarding any packing materials.

Some parts may have become loose during transit.

Step 1: Leg can be found in the zipper compartment .

Step 2: Insert the leg bolts into each of the threaded holes as seen below and rotate clockwise to secure the legs in place.

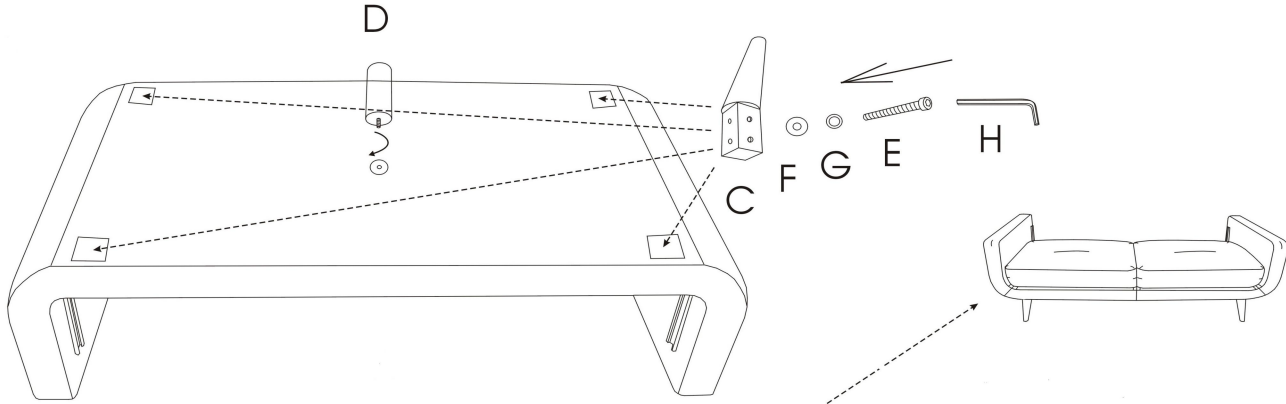

Step 3: Two person assembly insert the backrest into the body base on the both side at the same time . At the same time for quick and easy assembly .

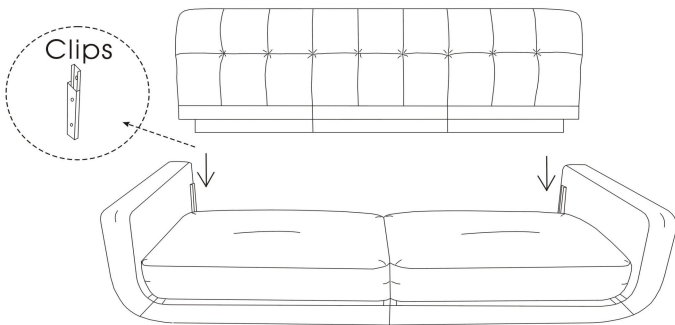

Complete: Your sofa should looks like this when assembled.

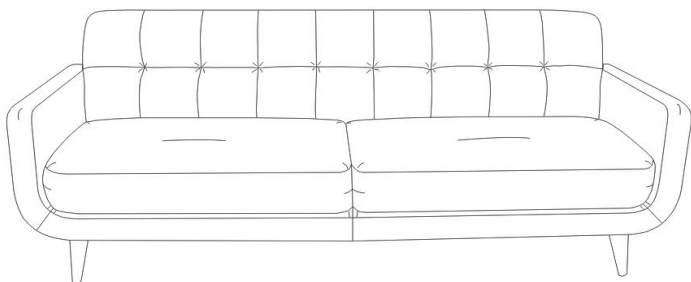

PARTS LIST

NO	SKETCH	DESCRIPTION	QTY
1		SEAT BASE	1 PC
2		BACKREST	1 PC
3		WOOD LEG	4 PCS
4		MIDDLE LEG	1 PC
5		SCREW	8 PCS
6		LOCK WASHER	8 PCS
7		FLAT WASHER	8 PCS
8		ALLEN KEY	1 PC

ASSEMBLY INSTRUCTIONS

Item #: Hadley Loveseat

Please identify and locate all assembly parts (see parts list) before discarding any packing materials.

Some parts may have become loose during transit.

Step 1: Leg can be found in the zipper compartment .

Step 2: Insert the leg bolts into each of the threaded holes as seen below and rotate clockwise to secure the legs in place.

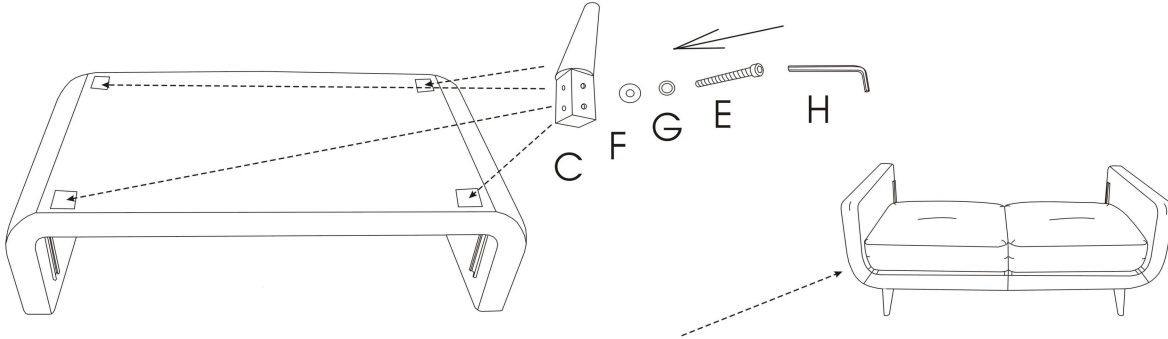

Step 3: Two person assembly insert the backrest into the body base on the both side at the same time . At the same time for quick and easy assembly .

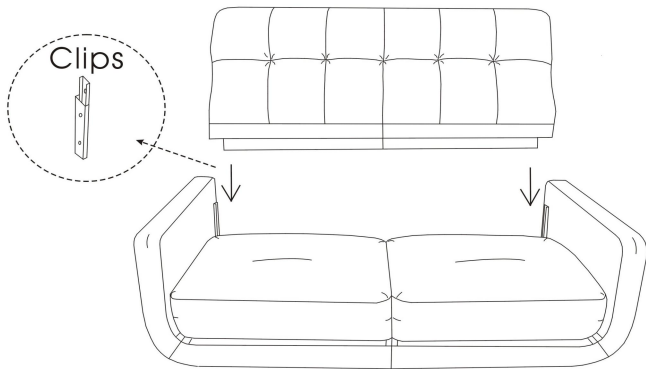

Complete: Your Loveseat should looks like this when assembled.

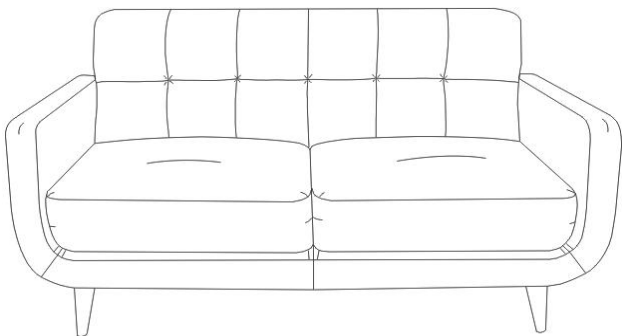

PARTS LIST			
NO	SKETCH	DESCRIPTION	QTY
1		SEAT BASE	1 PC
2		BACKREST	1 PC
3		WOOD LEG	4 PCS
4		SCREW	8 PCS
5		LOCK WASHER	8 PCS
6		FLAT WASHER	8 PCS
7		ALLEN KEY	1 PC

ASSEMBLY INSTRUCTIONS

Item #: Hadley Chair

Please identify and locate all assembly parts (see parts list) before discarding any packing materials.

Some parts may have become loose during transit.

Step 1: Leg can be found in the zipper compartment .

Step 2: Insert the leg bolts into each of the threaded holes as seen below and rotate clockwise to secure the legs in place.

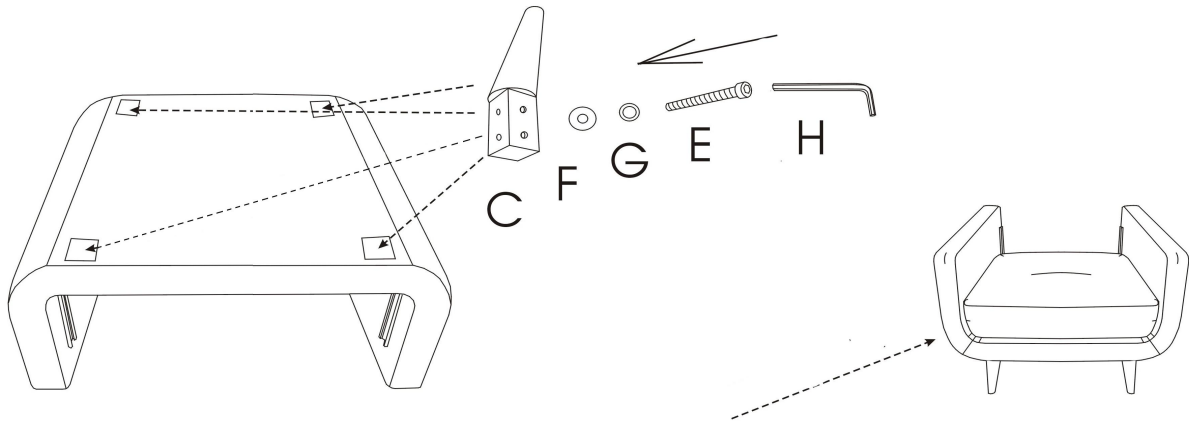

Step 3: Two person assembly insert the backrest into the body base on the both side at the same time . At the same time for quick and easy assembly .

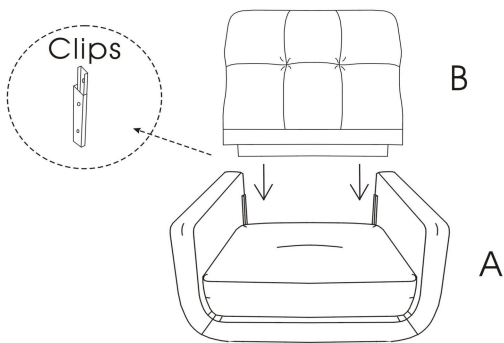

Complete: Your Chair should looks like this when assembled.

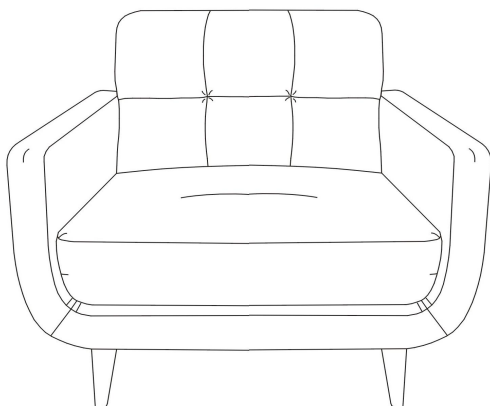

PARTS LIST

NO	SKETCH	DESCRIPTION	QTY
1		SEAT BASE	1 PC
2		BACK REST	1 PC
3		WOOD LEG	4 PCS
4		SCREW	8 PCS
5		LOCK WASHER	8 PCS
6		FLAT WASHER	8 PCS
7		ALLEN KEY	1 PC