

Congratulations on choosing your boxed pocket spring mattress! This manual will guide you through the unboxing process, provide tips for daily care and maintenance, and explain our after-sales service policy.

Unboxing Guide

Your mattress has been compressed and carefully packed in a box for convenient transport. Please follow the steps below to carefully unbox your mattress and allow it to fully expand:

1

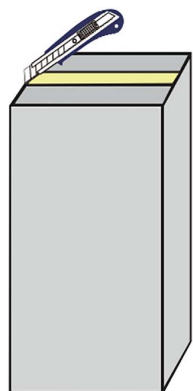

Upon receiving the package, lay it in your bedroom and use scissors to open it within 72 hours.

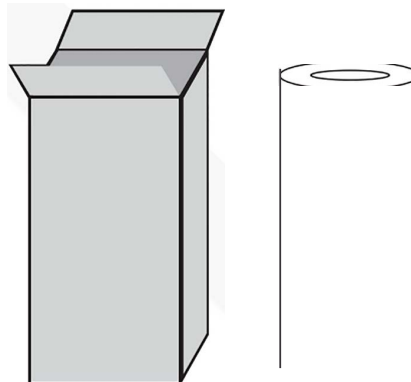

Take the mattress out of the box.

3

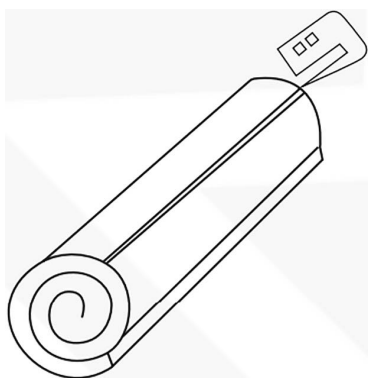

Remove the mattress from the plastic bag without using any sharp objects to avoid tearing or damage.

4

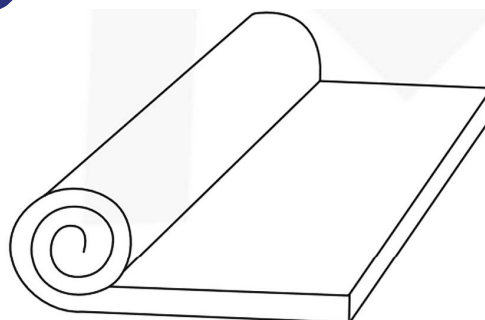

Place the rolled mattress on a clean, flat area or directly onto your bed, then unroll it gently.

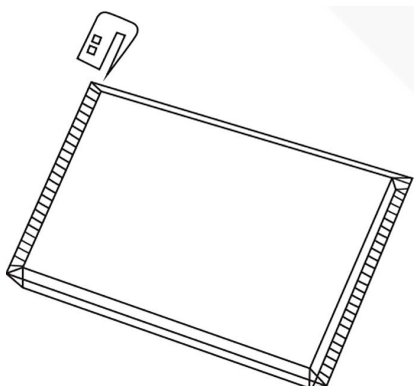

Open the plastic packaging along the edges with care, allowing the mattress to fully decompress. Remove the plastic wrap afterward.

6

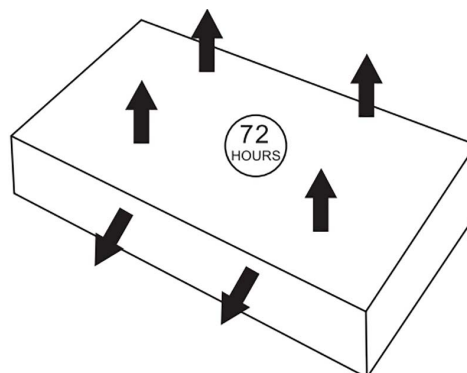

Give the mattress up to 72 hours to expand completely. For any slight odor, place it in a ventilated space to air out naturally.

Cleaning & Maintenance

Proper cleaning and maintenance will extend the life of your mattress, ensuring you enjoy comfortable sleep for longer.

- **Rotate Your Mattress:** We recommend rotating your mattress head-to-foot every 3-6 months. This ensures even wear and helps prolong its lifespan. Please do not flip the mattress vertically.
- **Routine Cleaning:**
 - **Vacuuming:** Regularly vacuum the surface of your mattress to remove dust, dead skin cells, and debris.
 - **Spot Cleaning:** For small stains, use a small amount of mild soap solution or a specialized mattress cleaner. Dampen a cloth with the solution, gently dab the stain, and then use a clean, dry cloth to blot dry. Avoid over-saturating the mattress.
 - **Do Not Wet or Dry Clean:** Do not immerse your mattress in water or have it dry cleaned, as this may damage the internal structure.
- **Ventilation:** Maintain good ventilation in your bedroom and regularly air out your mattress. This helps prevent moisture buildup and odors.
- **Mattress Protector:** We highly recommend using a **stain-resistant mattress protector**. It effectively guards against stains, dust, and allergens, and helps maintain your warranty coverage.
- **Avoid Jumping:** Do not jump on the mattress, as this can damage its spring structure.
- **Avoid Prolonged Heavy Pressure:** Avoid placing excessively heavy objects on specific areas of the mattress for extended periods.
- **Foundation/Base:** Ensure your mattress is placed on an **appropriate and supportive foundation, platform, or base**. An improper or inadequate base can damage the mattress and may void your warranty.

Limited Warranty Policy

Our mattresses come with a Limited Warranty to ensure your satisfaction.

Warranty Period

Your mattress is covered by a **10-year** Limited Warranty from the date of purchase against defects in workmanship and materials. The mattress cover is warranted for **two (2) years** for defects in material or workmanship.

What's Covered?

During this Limited Warranty period, if your mattress is deemed defective due to faulty workmanship or structural defects, we will, at our option, **repair or replace** it. Our responsibility is limited to this repair or replacement as stated below. This warranty applies only to the **original purchaser** and requires the original sales invoice as proof of purchase.

What's Not Covered?

This warranty does **not** cover:

- **Normal changes in softness** or resilience that can occur during the normal break-in period, or a lessening of the gradual recovery aspect of visco-elastic memory foam, provided such changes do not reduce the pressure-reducing and pressure-relief properties of the mattress.
- **Normal impressions** less than 1.5 inches in depth, not associated with a sag in the foundation, box spring, platform, or frame.
- **Normal wear and tear.**
- Damage resulting from **misuse or improper maintenance**, including but not limited to:
 - **Improper foundations or bases:** Using a foundation, platform, or other base that is not appropriate or supportive for the mattress. It is the consumer's responsibility to maintain the foundation and provide appropriate support.
 - **Physical damage:** Intentional damage, accidents, and/or neglect, including burns, cuts, water damage, mold, stains, or if the product is abnormally soiled or unsanitary.
 - Damage caused by fire, flooding, roughhousing, inadequate support, or excessive weight imposed on the mattress.

- **Alteration or repair by unauthorized representatives.**
- **Removal of the mattress cover:** The mattress cover is not designed for laundering or other care. **Removing the mattress cover will void this Limited Warranty**, as it affects the flammability performance and poses health and safety risks.
- Use of **heating pads or electric blankets** with the mattress.
- **Handles:** Handles are for adjustment purposes only and are not intended for lifting, turning, or transporting the product.
- **Transportation costs:** All transportation costs related to warranty claims are the responsibility of the purchaser during the entire Limited Warranty period.
- **Comfort preferences:** Individual comfort preferences, sheet fit, or height issues resulting from the purchaser's bed frame size or headboard style.
- **Medical conditions:** We do not warrant our product as a remedy for any specific medical condition, nor do we warrant against complications from the use or inability to use this product.

Important: All mattresses submitted for warranty coverage must retain their **original labels and tags**, including the required law label, and must be in **clean condition**. The law tag must not be removed from the original product as it identifies the product.

Service & Support

Should a warranty claim arise, the original purchaser should contact us for Warranty Claim Instructions. You will be required to complete a Warranty Claim Form, clearly detailing the defect, and email it along with a copy of your **original sales receipt** for the product. Incomplete forms or those sent without the original sales receipt will not be processed.

Upon receipt of the completed form and sales receipt, our representative or designated agent will make the final determination regarding repair or replacement. If this Limited Warranty is applicable, a replacement product of equal or greater value (at our option, especially if a model has been discontinued) will be sent to you. The original purchaser will be responsible for shipping, handling, and processing fees. **No monetary refunds and/or credits will be issued.**

Please retain this warranty document and your original invoice for ten (10) years for future reference.

Legal Disclaimers

Limitation of Implied Warranties:

We limit the duration and remedies of all implied warranties, including without limitation the warranties of merchantability and fitness for a particular purpose, to the duration of this express limited warranty. Some states do not allow limitations on how long an implied warranty lasts, so the above limitation may not apply to you.

Limitation of Liability:

The remedies described above are your sole and exclusive remedies and our entire liability for any breach of this limited warranty. Our liability shall under no circumstances exceed the actual amount paid by you for the defective product, nor shall we under any circumstances be liable for any consequential, incidental, special, or punitive damages or losses, whether direct or indirect. Some states do not allow the exclusion or limitation of incidental or consequential damages, so the above limitation or exclusion may not apply to you.

Your Legal Rights:

This limited warranty gives you specific legal rights, and you may also have other rights that vary from state to state.

Body Conformity:

As with all premium sleep products, certain body conformity adaptations will take place as your mattress adapts to your particular body shape and type and any peculiarities in your spinal alignment or bone structure. This is to be expected and is part of the performance of your mattress.

Warranty Duration Not Extended: Should this limited warranty be exercised and your product replaced and/or repaired, the duration of the limited warranty will not be extended or restarted.