

Product size:
2-Seat Sofa: W141*D76*H71cm
Armchair: W81*D76*H71cm

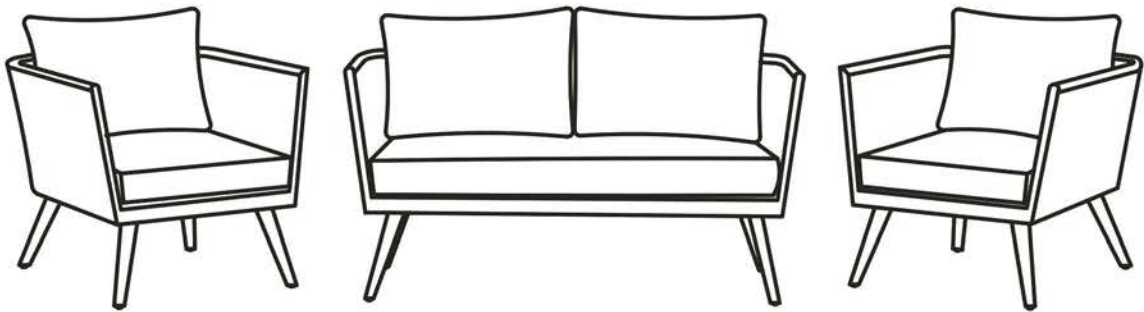

The intended use of this product is for domestic use only.

Important, please retain for future reference.

Read carefully.

2-Seat Sofa and Armchairs

Assembly Instructions

Before you start



Warnings

IMPORTANT, RETAIN FOR FUTURE REFERENCE READ CAREFULLY

See enclosed instructions for assembly, safety and care information.

Failure to follow the warnings could result in serious injury.

Handle heavy parts with care.

Ensure that this product is fully assembled as illustrated before use.

This product should only be used on firm, level ground.

Keep small parts out of reach of children.

Do not stand or climb onto this product.

This product is intended for **domestic use** only.

Furniture can be dangerous if incorrectly used. No liability will be accepted for damage or injury caused by incorrect use of this product.

✓ Dos

When you are ready to start, make sure that you have the right tools, plenty of space and a clean, dry area for assembly.

Remove all packaging and banding and place the components carefully on suitable surfaces to prevent damaging or scratching them.

Check the pack and make sure you have all of the parts listed.

Check all screws and bolts are tightened and inspect regularly.

This product is suitable for all year outdoor use, but we recommend that a furniture cover be used to add additional protection to your product when not in use.

During severe weather conditions and in the winter months we recommend moving your furniture inside into a cool, dry place.

Before storage, ensure that the product is clean and dry.

To clean, wipe down with a sponge and warm soapy water and wipe with a clean, dry cloth.

Cushions should be cleaned following the care instruction on the label.

If the set is stored outside then we recommend that cushions are brought inside for storage and protection.

Torrential rain! No problem, just shake it dry. Red Wine, Drinks & Sauce spillages! It's no problem, just wipe it off.

✗ Don'ts

Do not use scourers, abrasives, washing powders, chemical cleaners or any other substances containing abrasives since these substances can damage the product, including the glass panel.

Do not place very hot or very cold items on the glass surface unless adequately thick table-mats are used to prevent such items from coming into contact with the glass.

Do not use the glass as a chopping surface.

Do not strike the glass with hard or pointed items.

Do not use power tools to construct this product.

Do not use this product if parts are missing, damaged or worn.

Do not sit or lean on this product.

Do not stand or climb onto the product and do not use it as a ladder, as this could lead to it unbalancing and overturning.

Never drag furniture when moving it, always lift it.

Number of people required for assembly

Two people



Time to assemble



20 minutes

Tools required



Tips:

Do NOT fully tighten bolts before all components are connected. Only fully tighten once you are satisfied with the alignment of all components.

2-Seat Sofa and Armchairs Assembly Instructions



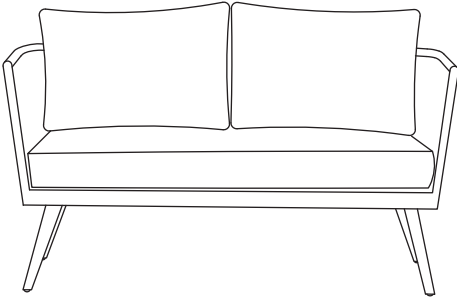
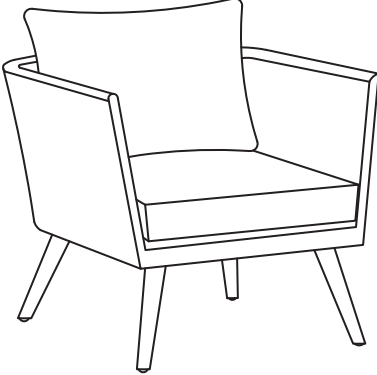

Member Parts

Part No.	Diagram	Name	Qty.
1		2-Seat Sofa	1 PC
2		Armchair	2 PCS

2-Seat Sofa and Armchairs

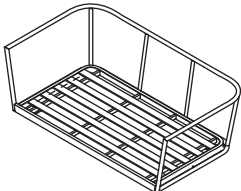
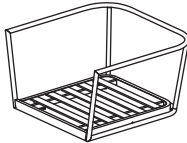
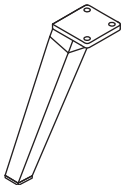
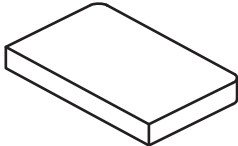
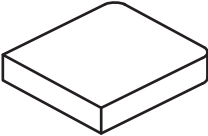
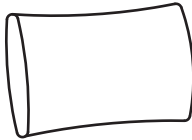
Assembly Instructions

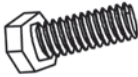
Components, fixtures & fittings (not actual size)

Parts List					
Part No.	Diagram	Qty.	Part No.	Diagram	Qty.
A	 2-Seat Sofa Seat	1 PC	B	 Armchair Seat	2 PCS
C	 Leg	12 PCS	D	 Sofa Seat Cushion	1 PC
E	 Armchair Seat Cushion	2 PCS	F	 Backrest Cushion	4 PCS
F2	 Bolt Head Cap	36 PCS	W25	 M6*25mm Bolt	36 PCS
F3	 Flat Washer	36 PCS	S1	 Spanner	1 PC

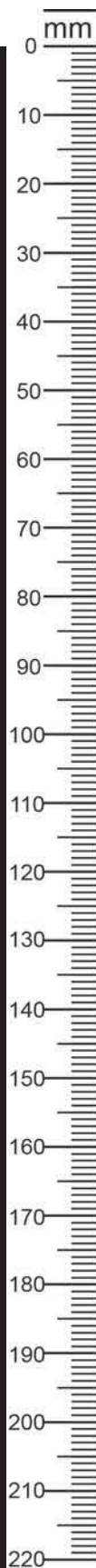

2-Seat Sofa and Armchairs

Assembly Instructions

Step by step assembly instructions

Part 1: 2-Seat Sofa

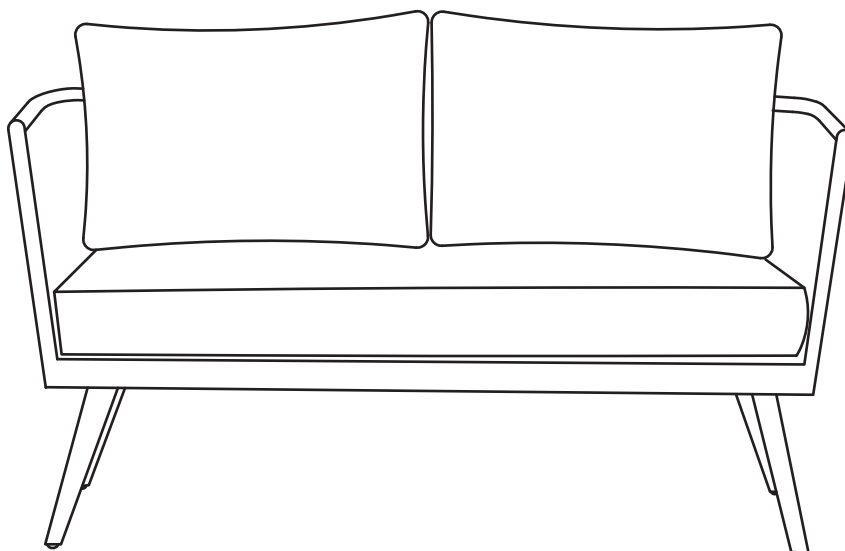

Step One

Open the packaging, with the help of another person, place the 2-Seat Sofa upside down on a flat, non-abrasive surface to avoid scratching the surface or rim.

Loosely attach the Legs (C) onto the Sofa Seat (A) using Flat Washers (F3), Bolts (W25) and Bolt Head Caps (F2).

Only tighten the bolts when all bolts and washers are in place and turn freely. Once you are satisfied with the alignment of the components carefully tighten all bolts using Spanner (S1). Do not over-tighten. Cover each bolt with Bolt Head Cap (F2).

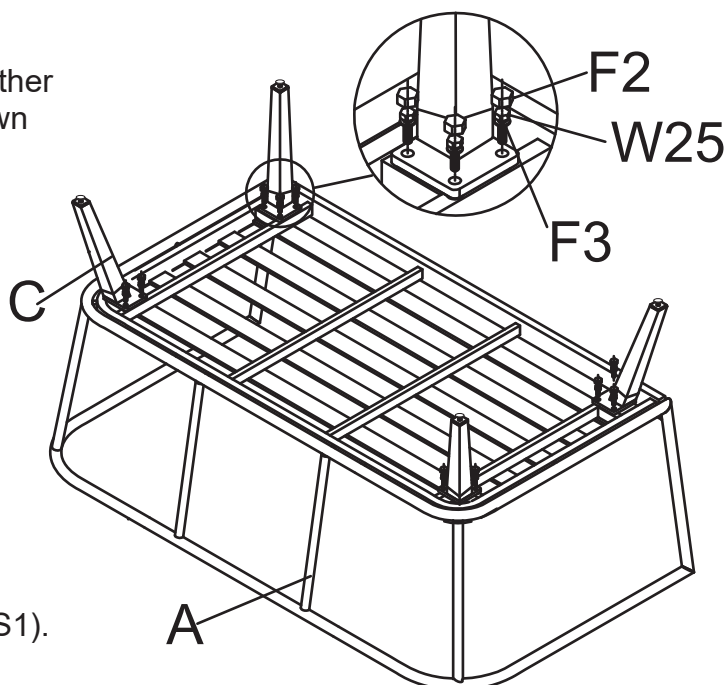

2-Seat Sofa and Armchairs Assembly Instructions

Step Two

With the help of another person, stand the 2-Seat Sofa.

Level the 2-Seat Sofa by adjustable feet screws.

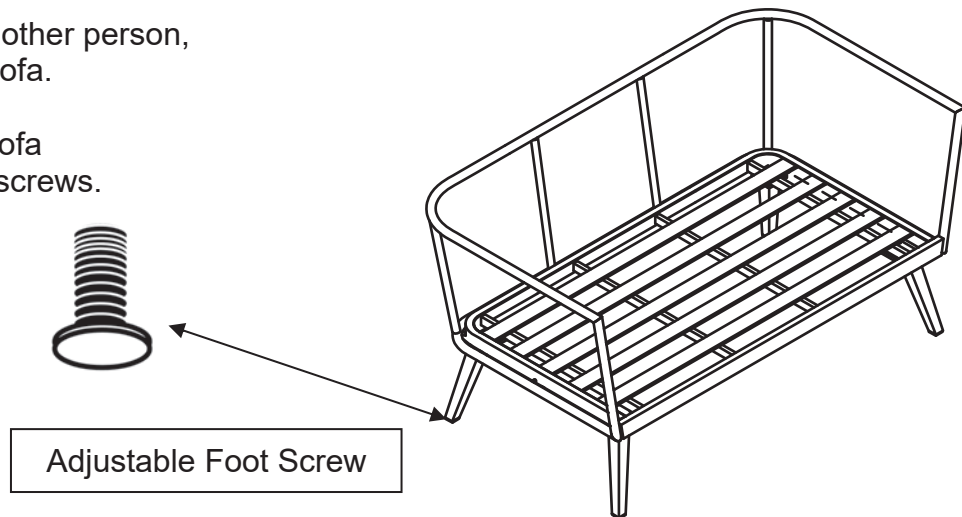

Step Three

Place the Sofa Seat Cushion (D) and Backrest Cushions (F) onto the 2-Seat Sofa Seat.

Your 2-Seat Sofa is now ready for use.

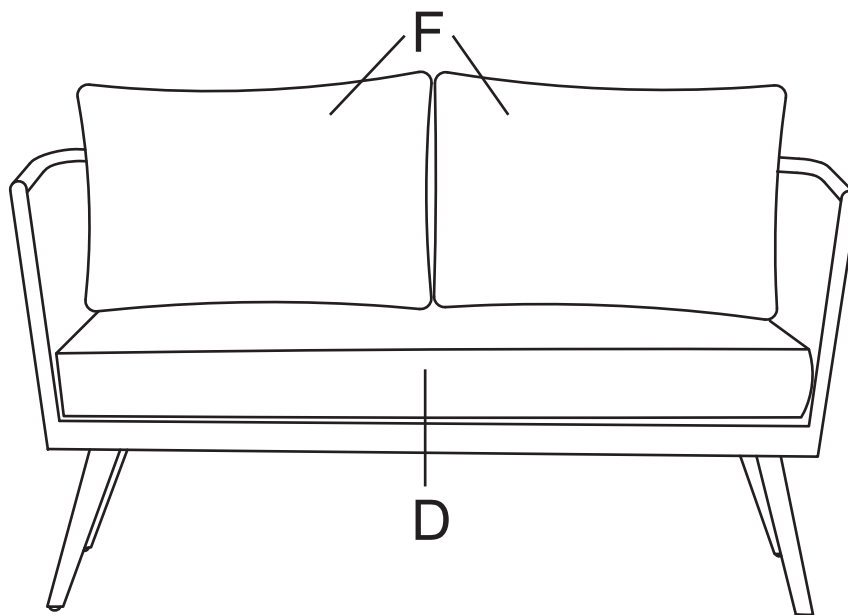

2-Seat Sofa and Armchairs

Assembly Instructions

Part 2: Armchair

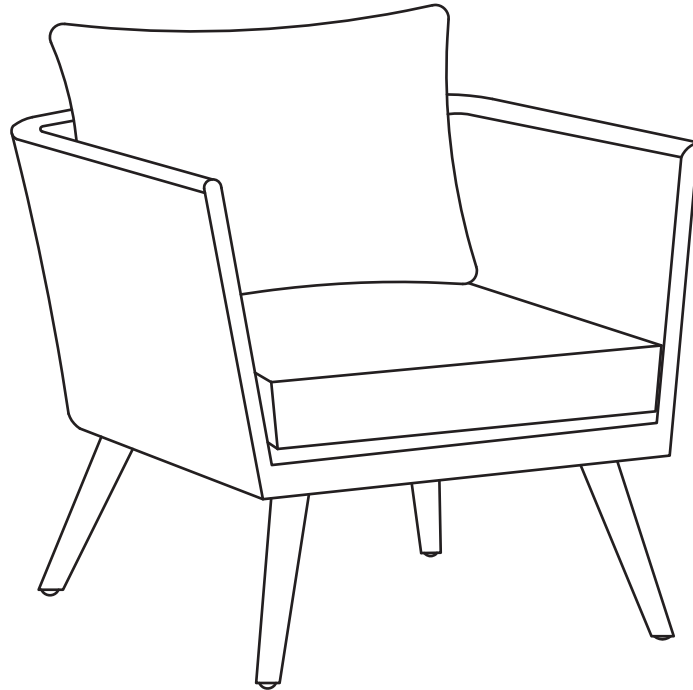

Step One

Open the packaging, with the help of another person, place the Armchair upside down on a flat, non-abrasive surface to avoid scratching the surface or rim.

Loosely attach the Legs (C) onto the Armchair Seat (B) using Flat Washers (F3), Bolts (W25) and Bolt Head Caps (F2).

Only tighten the bolts when all bolts and washers are in place and turn freely. Once you are satisfied with the alignment of the components carefully tighten all bolts using Spanner (S1). Do not over-tighten. Cover each bolt with Bolt Head Cap (F2).

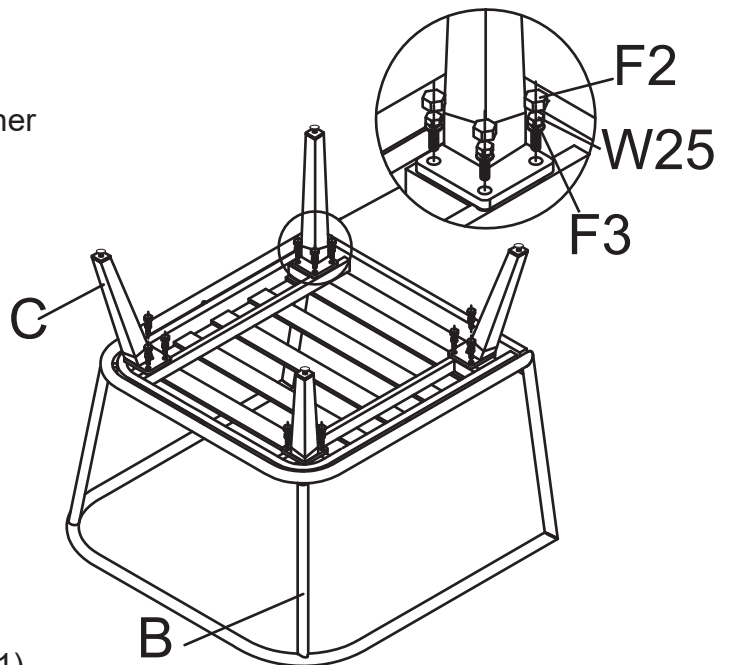

2-Seat Sofa and Armchairs Assembly Instructions

Step Two

With the help of another person, stand the Armchair.

Level the Armchair by adjustable feet screws.

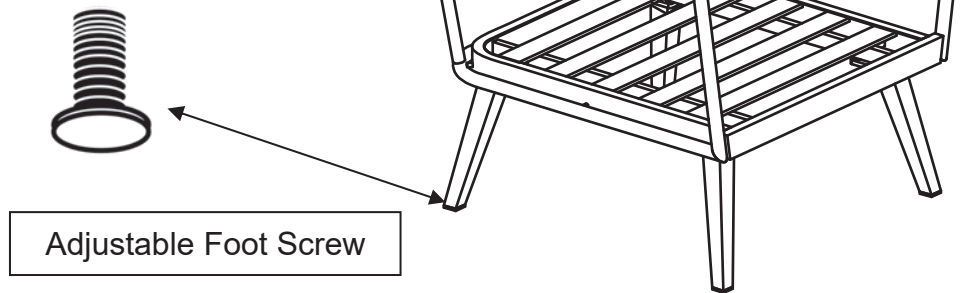

Step Three

Place the Armchair Seat Cushion (E) and Backrest Cushion (F) onto the Armchair Seat.

Your Armchair is now ready for use.

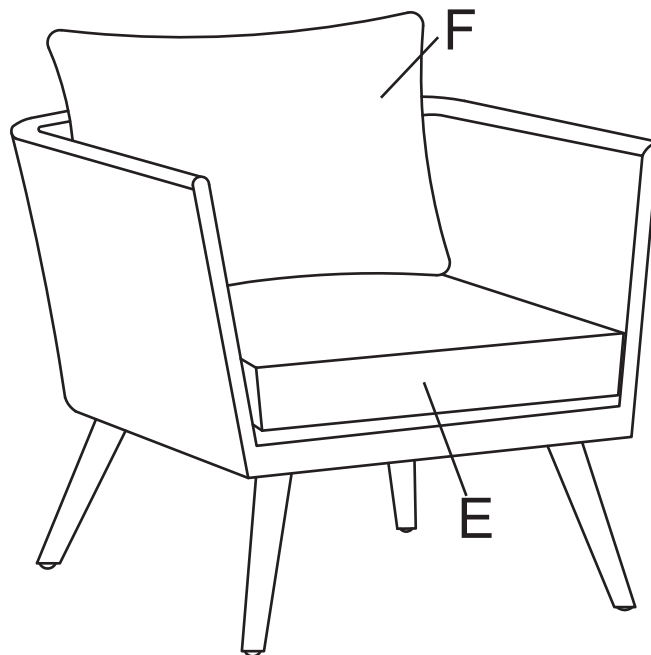

2-Seat Sofa and Armchairs Assembly Instructions

Never tilt the products during use.
Ensure the product is always placed firmly on the ground.

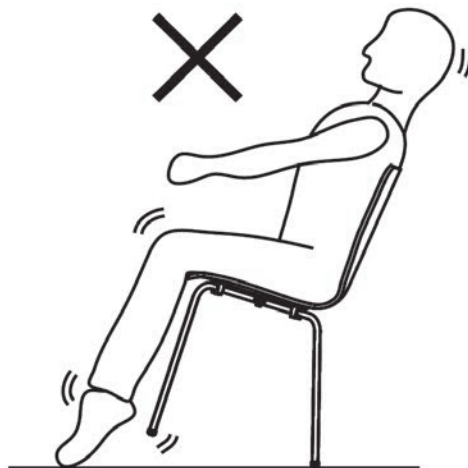

PLEASE KEEP THESE INSTRUCTIONS FOR FUTURE REFERENCE