

INSTALLATION AND OPERATING MANUAL

VIDALUX

SS1200 Rectangular



INSTALLERS PLEASE NOTE, THESE
INSTRUCTIONS ARE TO BE LEFT WITH
THE CUSTOMER

Technical Support: 01524 489939

Warranty Claims Or Delivery Damage: www.vidalux.co.uk

VIDALUX CLEAR & BRIGHT WATER SOFTENER

Guaranteed to get rid of limescale

Live in a hard water area?? Limescale in the kettle and on bathroom fixtures?? Suffering from unknown adverse health effects from this polluted drinking water??

If you have a steam shower and the generator becomes blocked with limescale and stops working THIS IS NOT COVERED BY THE WARRANTY, as in reality it is not the products fault, it's the poor quality water it has been subjected to

GOOD NEWS - Designed in partnership with one of the UK's largest and most trusted water softener manufacturers, this sleek, easy fit model is GUARANTEED to work or your money back!! Remove all the limescale in a 1-4 bedroom home and benefit from the following

Better tasting drinking water - Easy to install - Guaranteed to work or your money back
No plumbing or chemicals – Cost as little as £2.00 a year to run and the improved condition of the water pipes will reduce your heating bills - Made in the U.K - Trialled and tested Over 10 years | Used by professionals



Thank you for purchasing this product. To guarantee the product delivers a long service life, please ensure it is fitted and used in accordance with the instructions contained in this booklet.



Please check that the boxes contain all the items listed below, and report to us any parts that are missing or damaged prior to assembly and within 48 hours of receipt. Damages notified to us after this time will be chargeable.

CAREFULLY CHECK THE PRODUCT IS AS ORDERED: CORRECT SIZE AND COLOUR OPTION BEFORE YOU COMMENCE ANY OF THE INSTALLATION PROCESS







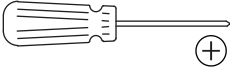

You should ensure that the floor where the shower is to be located is smooth, level and able to support the weight of the product when in use.

Installation of the shower cabin is designed for a DIY installation. However any electric supply to the unit itself is required by law to be installed by a qualified trades person to ensure safety and quality. Failure to have the showers electric feed installed by qualified fitters will invalidate your product guarantee and be dangerous.

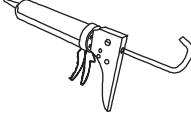
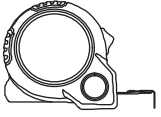

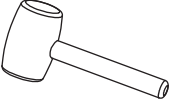
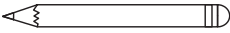

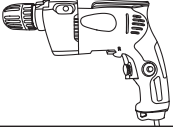

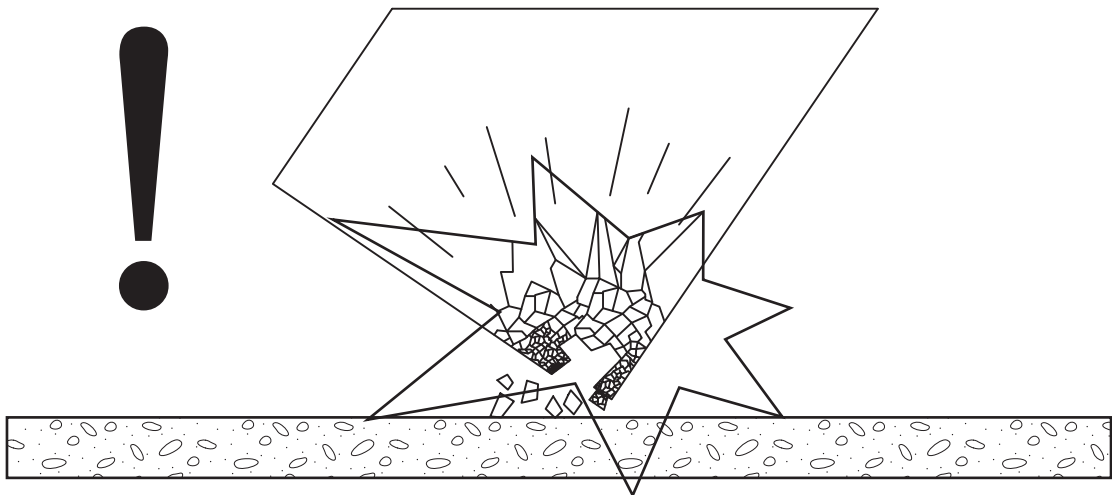
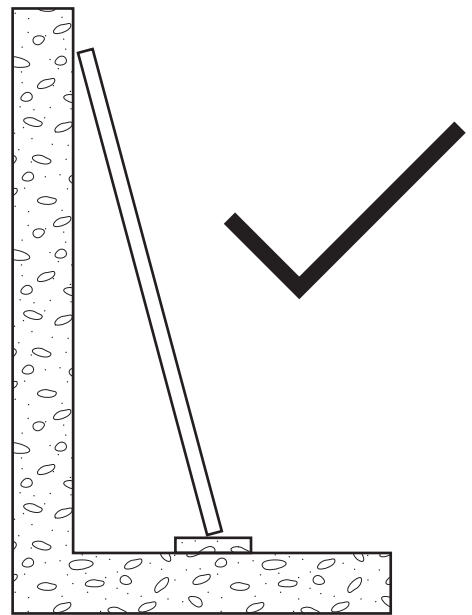
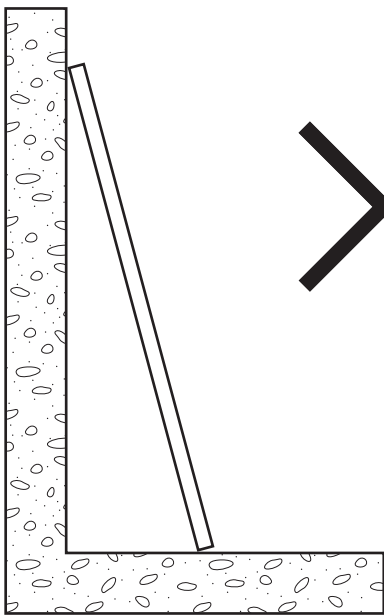

Please ensure that all connections are water tight, safe and insulated (where applicable) as the unit has connections that are made for transport purposes only and are not fully tightened.

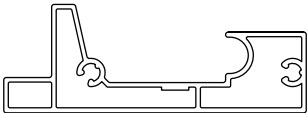
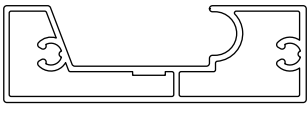
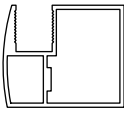
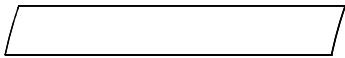



Refer also to contents list with images on the next pages.

No installation should take place until all items have been deemed cosmetically acceptable. Once installation commences all products then enter into their governing warranty periods and no returns can be accepted, by commencing with the installation you are accepting the goods cosmetic state with all 'workings' being covered by warranty. (contact us for more information before installing if required)

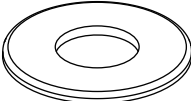
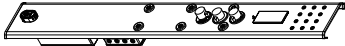
| | | | |
|--|---|--|---|
|  |  |  |  |
|  |  |  |  |
|  ø 4mm |  |  | |

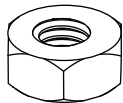

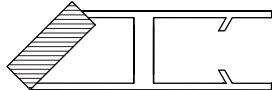
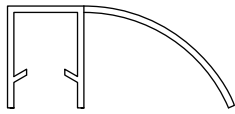
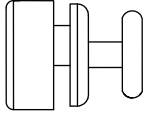
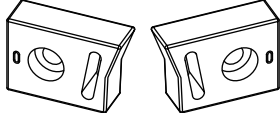
| Serial Number | Graphics | Name | Quantity | Remark |
|---------------|---|------------|----------|--------|
| 01 |  | | 1 | |
| 02 |  | | 1 | |
| 03 | | 2 | L/R | |
| 04 |  | | 2 | L/R |
| 05 |  | | 2 | L/R |
| 06 |  | ST4 × 16mm | 22 | |
| 07 |  | ST4 × 25mm | 2 | |
| 08 |  | | 2 | L/R |
| 09 |  | | 2 | L/R |
| 10 |  | ST4 × 10mm | 32 | |
| 11 |  | | 1 | |
| 12 |  | | 1 | |
| 13 |  | | 36 | |
| 14 |  | | 1 | |

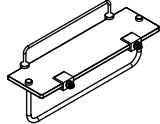
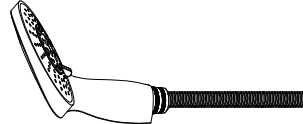
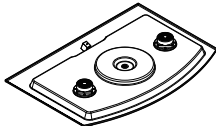
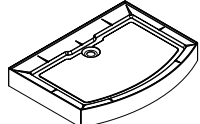
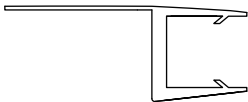
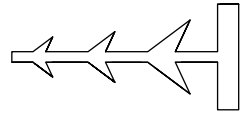
| Serial Number | Graphics | Name | Quantity | Remark |
|---------------|---|-----------|----------|--------|
| 15 |  | M4 × 20mm | 12 | |
| 16 |  | | 12 | |
| 17 |  | | 2 | |
| 18 |  | | 2 | |
| 19 |  | | 2 | |
| 20 |  | | 8 | |
| 21 |  | | 8 | L/R |
| 22 |  | | 2 | |
| 23 |  | | 1 | |
| 24 |  | | 1 | |
| 25 |  | | 1 | |
| 26 |  | | 1 | |
| 27 |  | | 2 | |
| 28 |  | | 4 | |

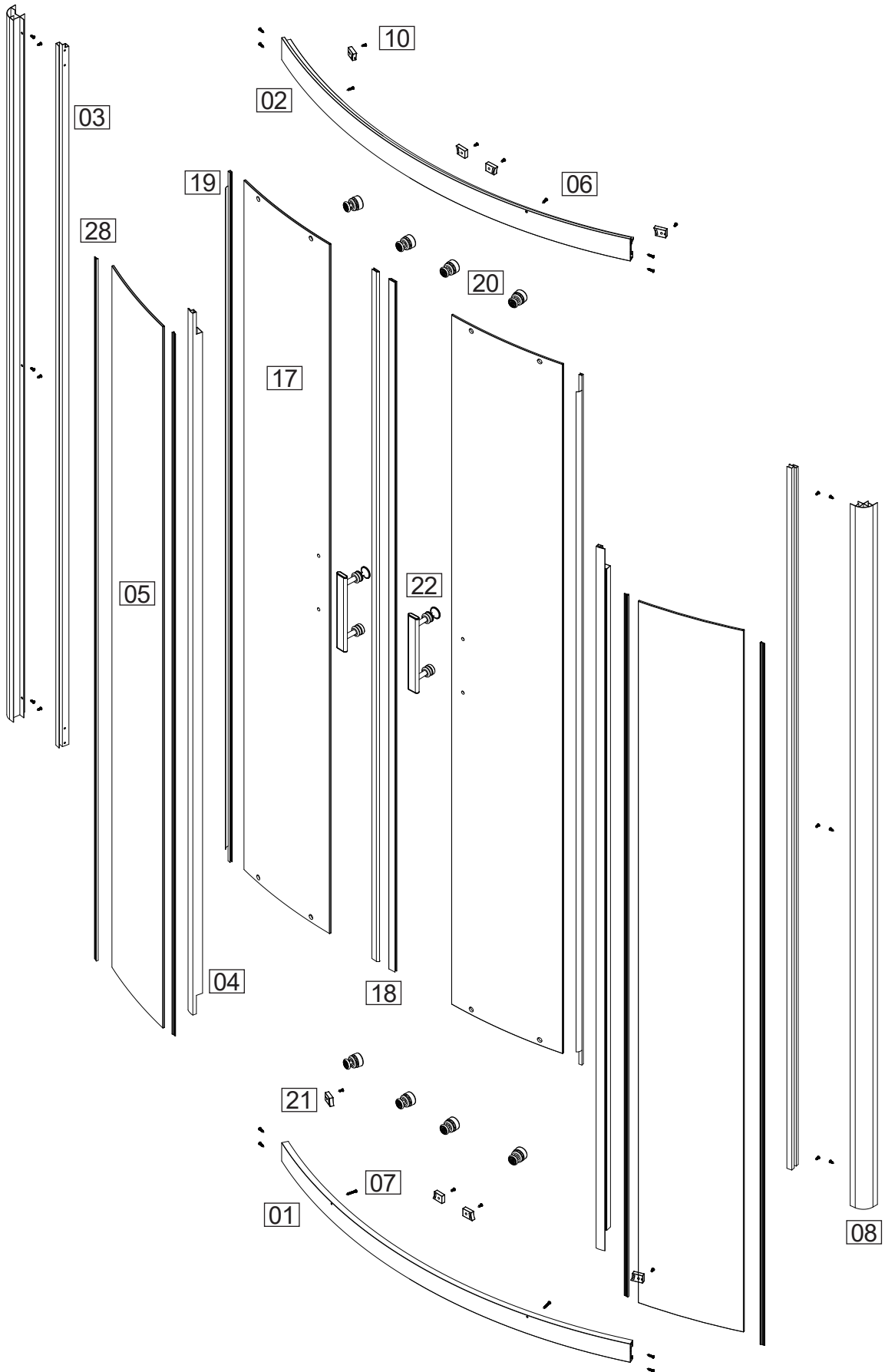

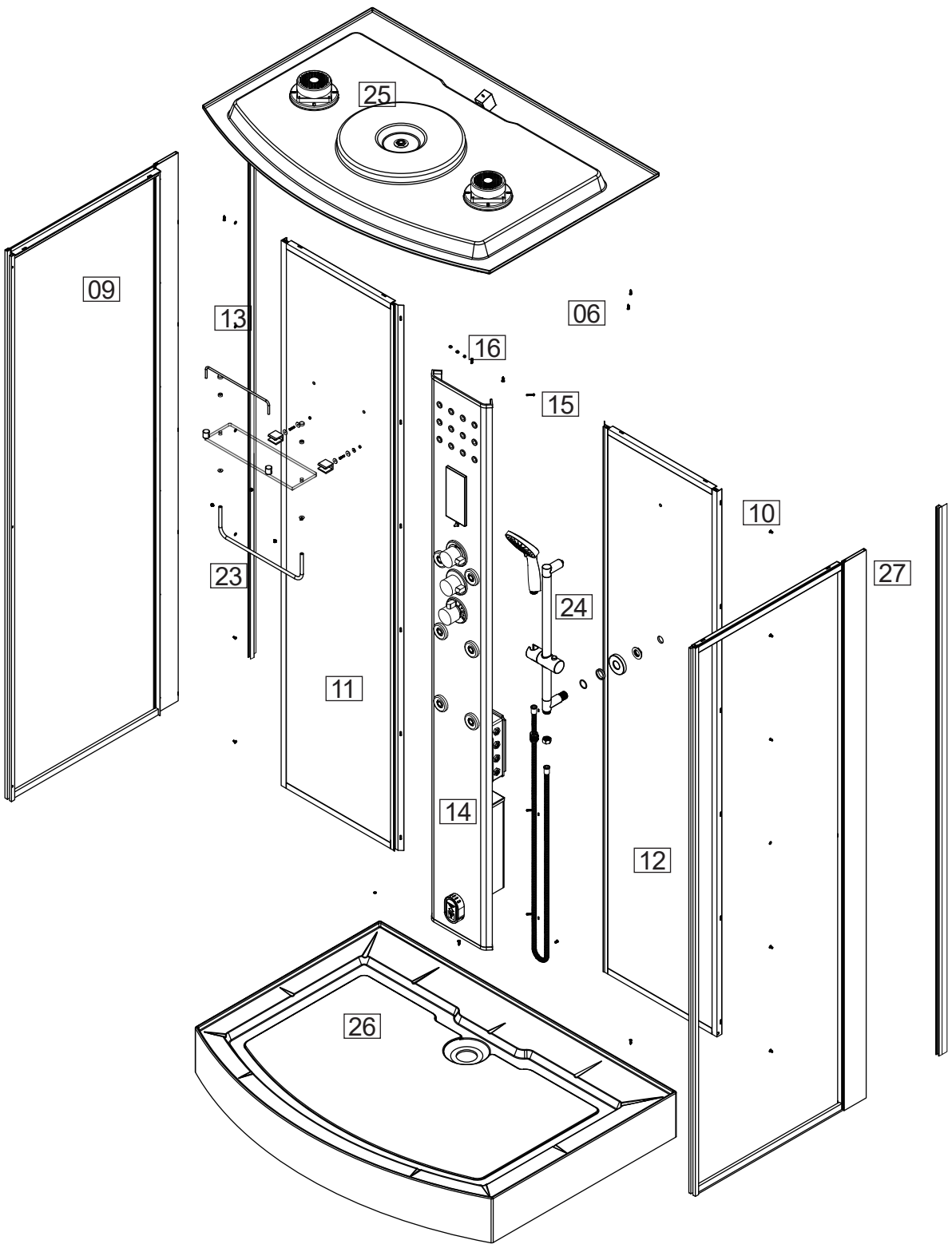

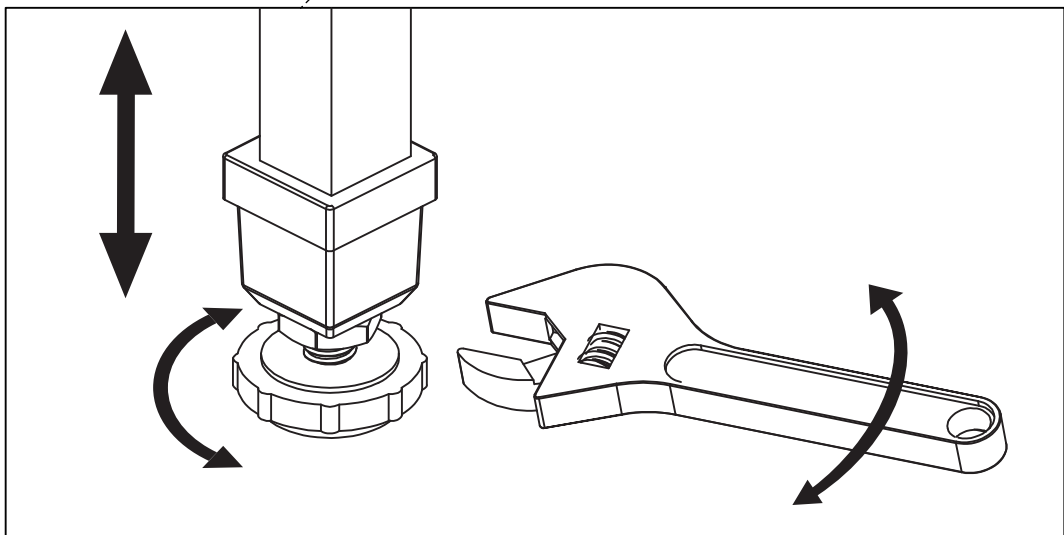
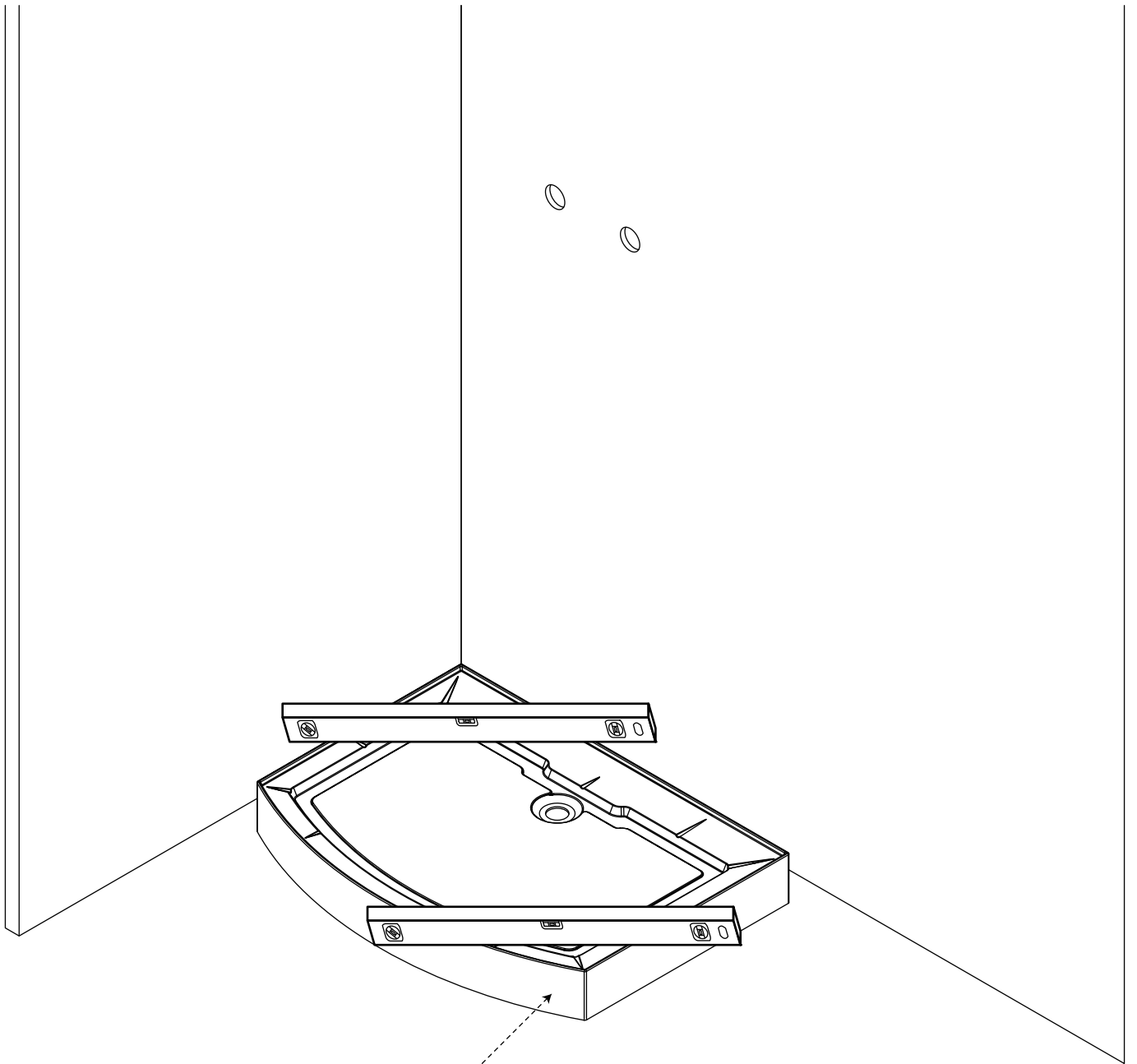

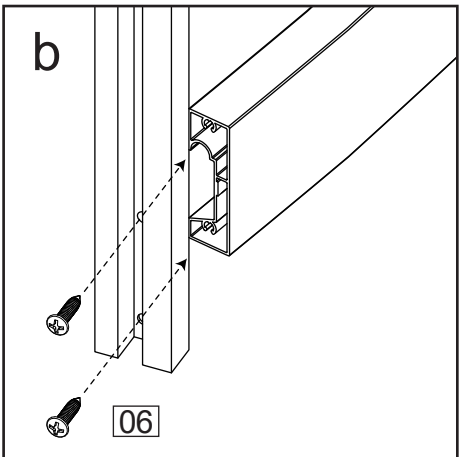
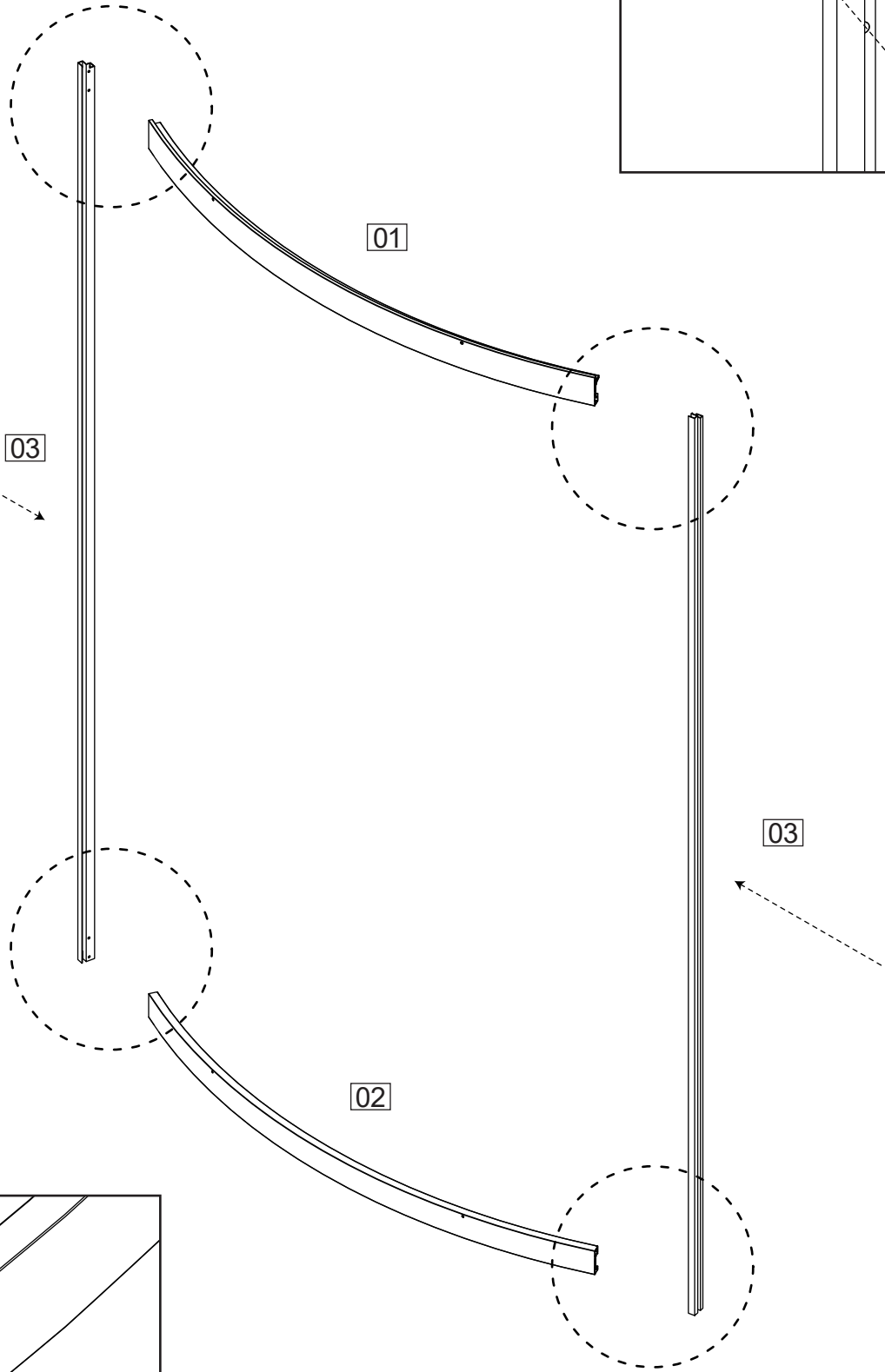
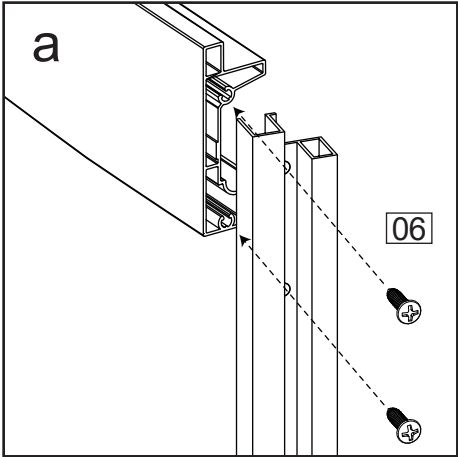

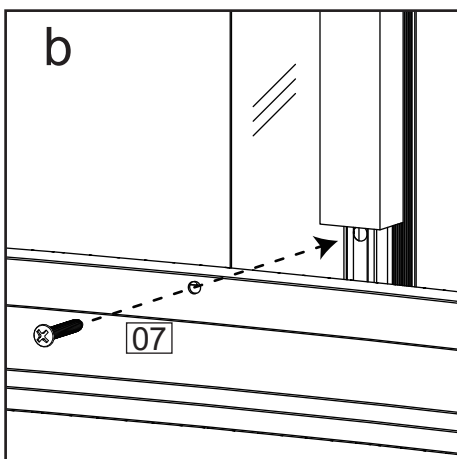
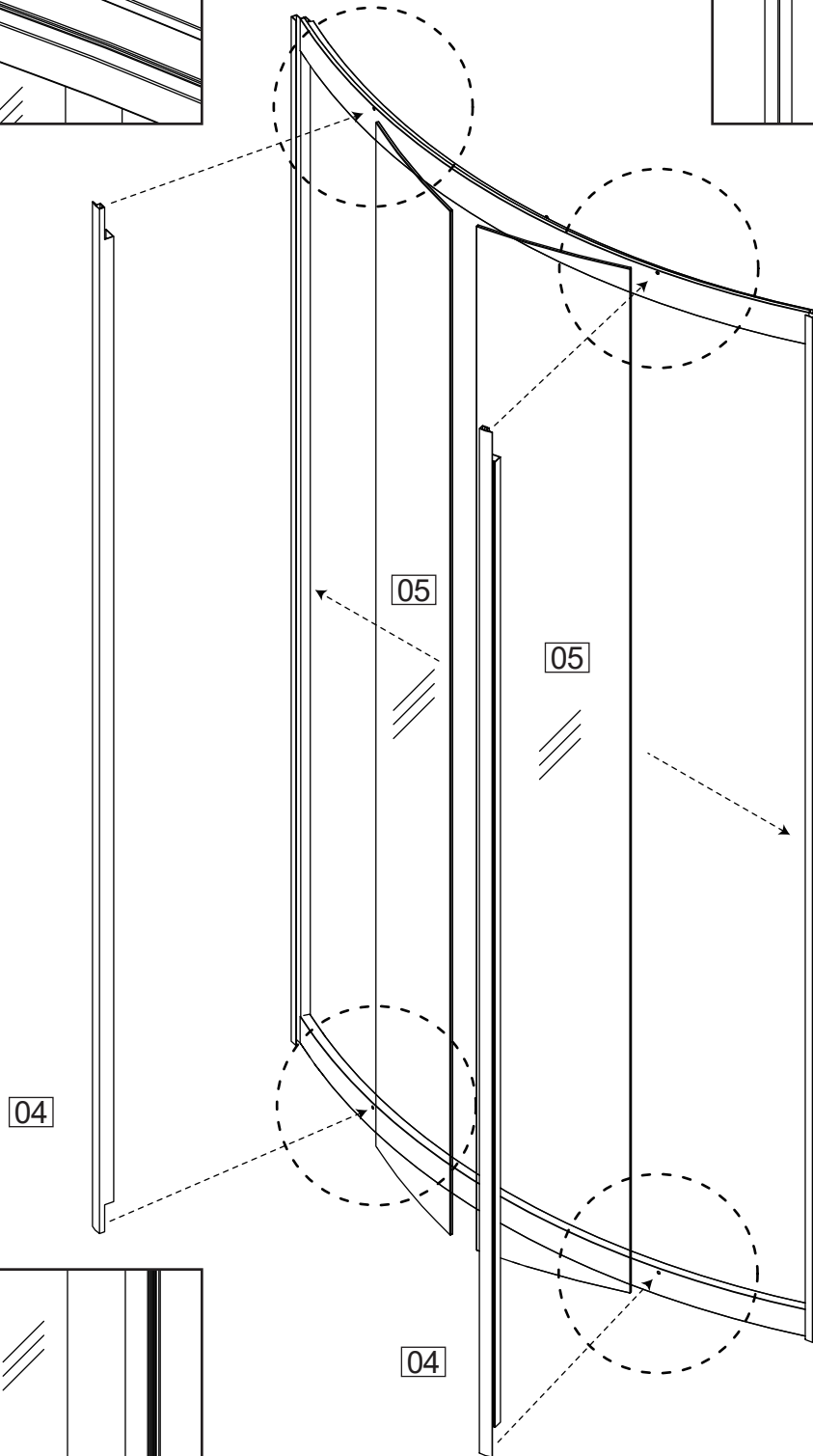
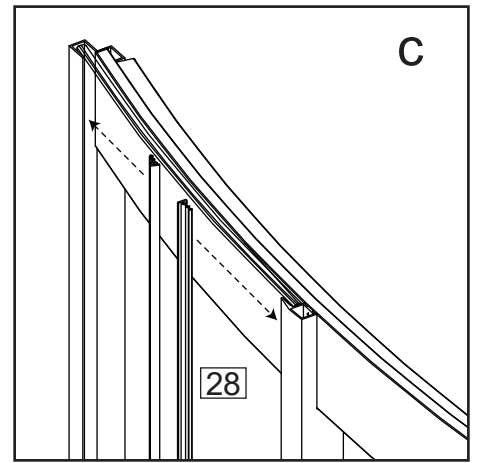
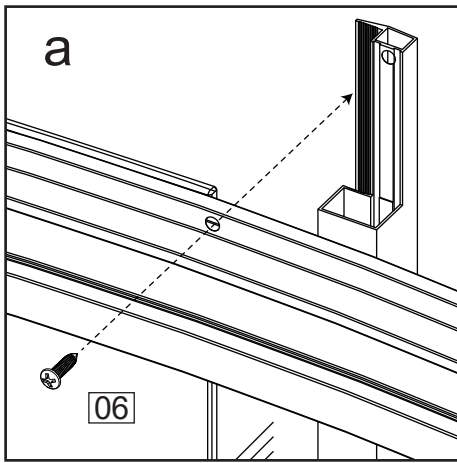

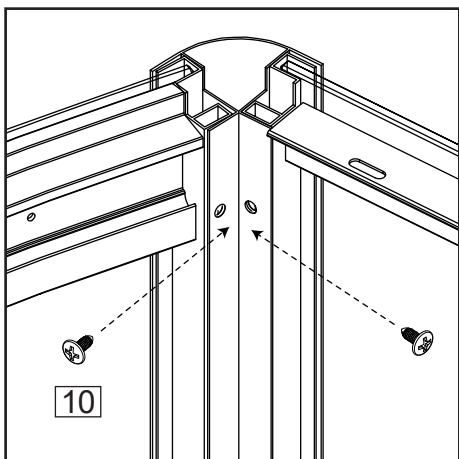
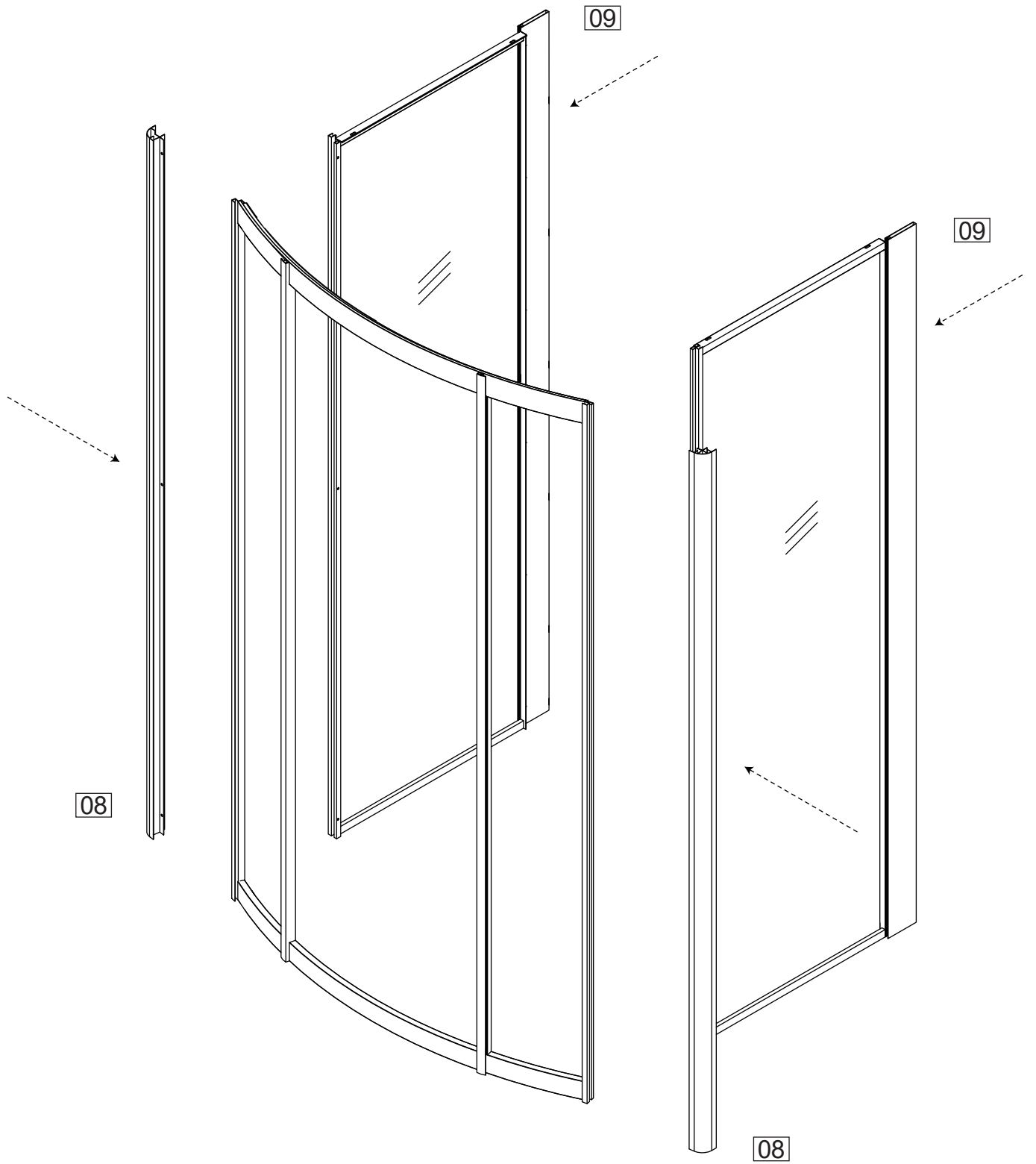

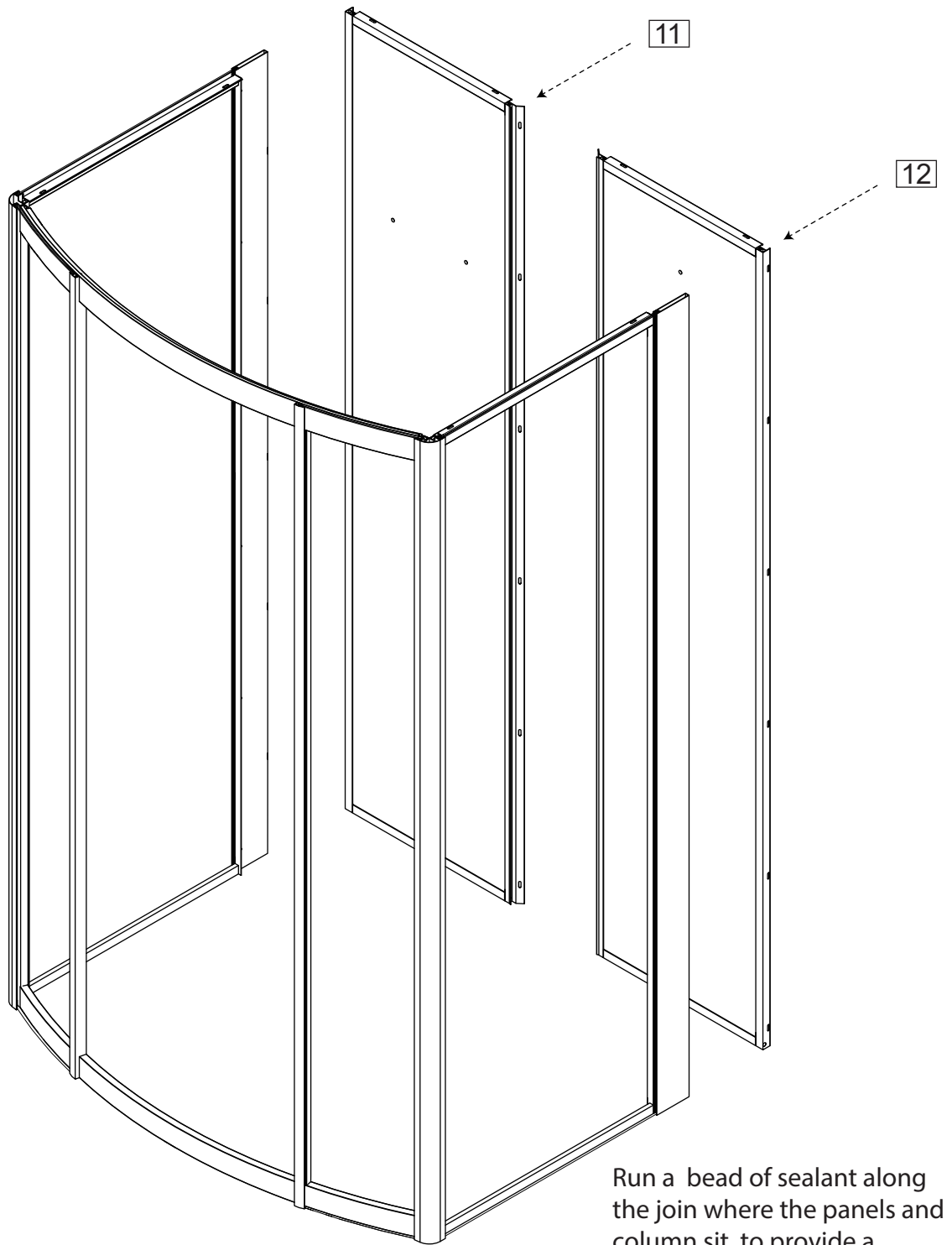

Run a bead of sealant along the join where the panels and column sit ,to provide a watertight barrier.

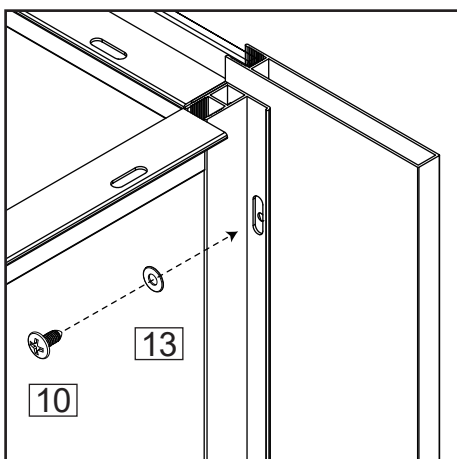

Remember to remove any excess sealant once the panels have been seated into position.

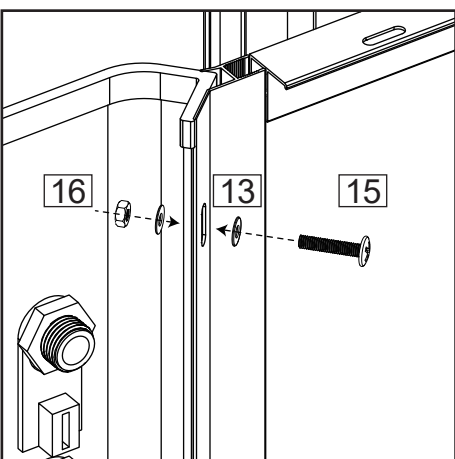
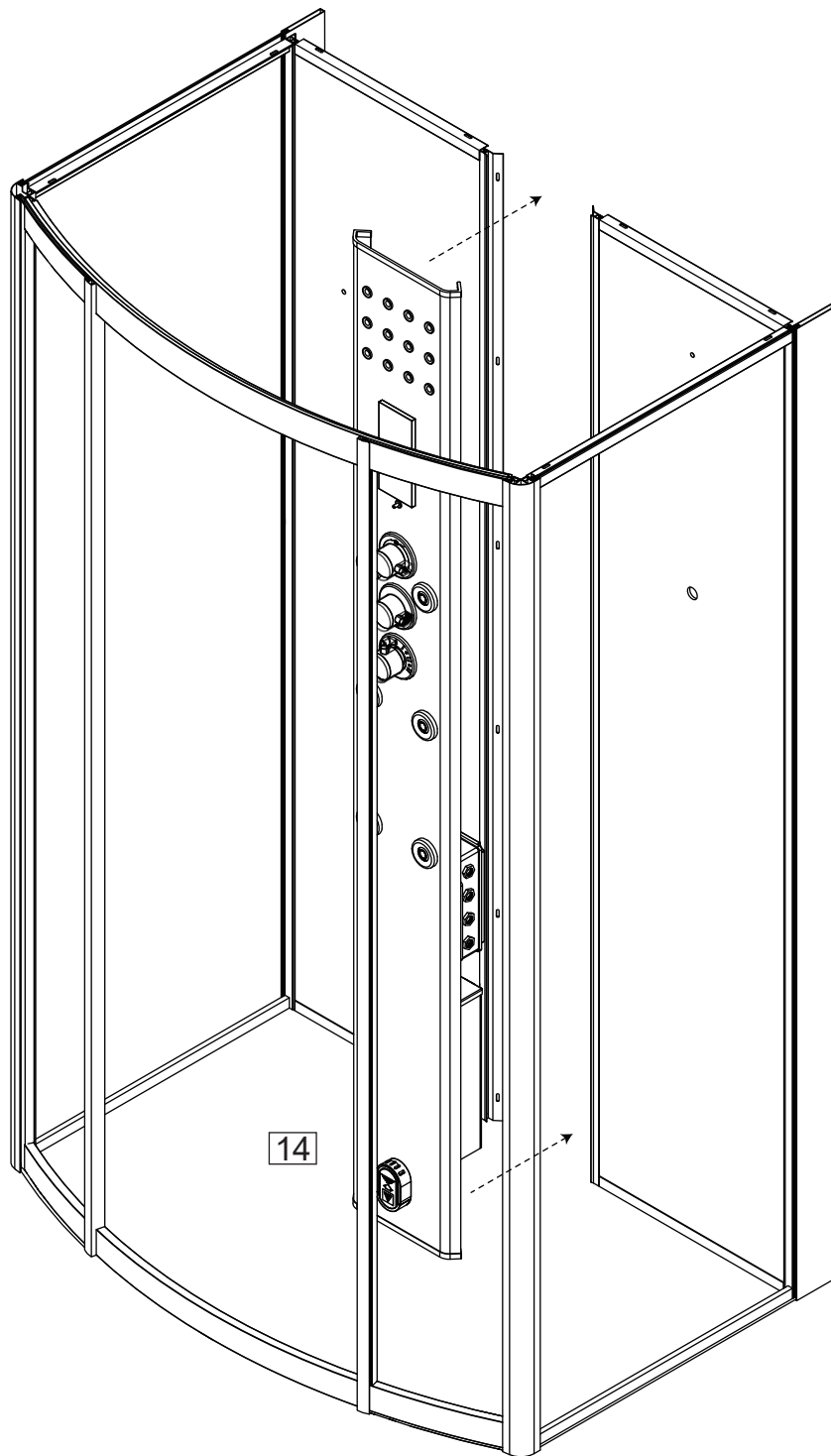

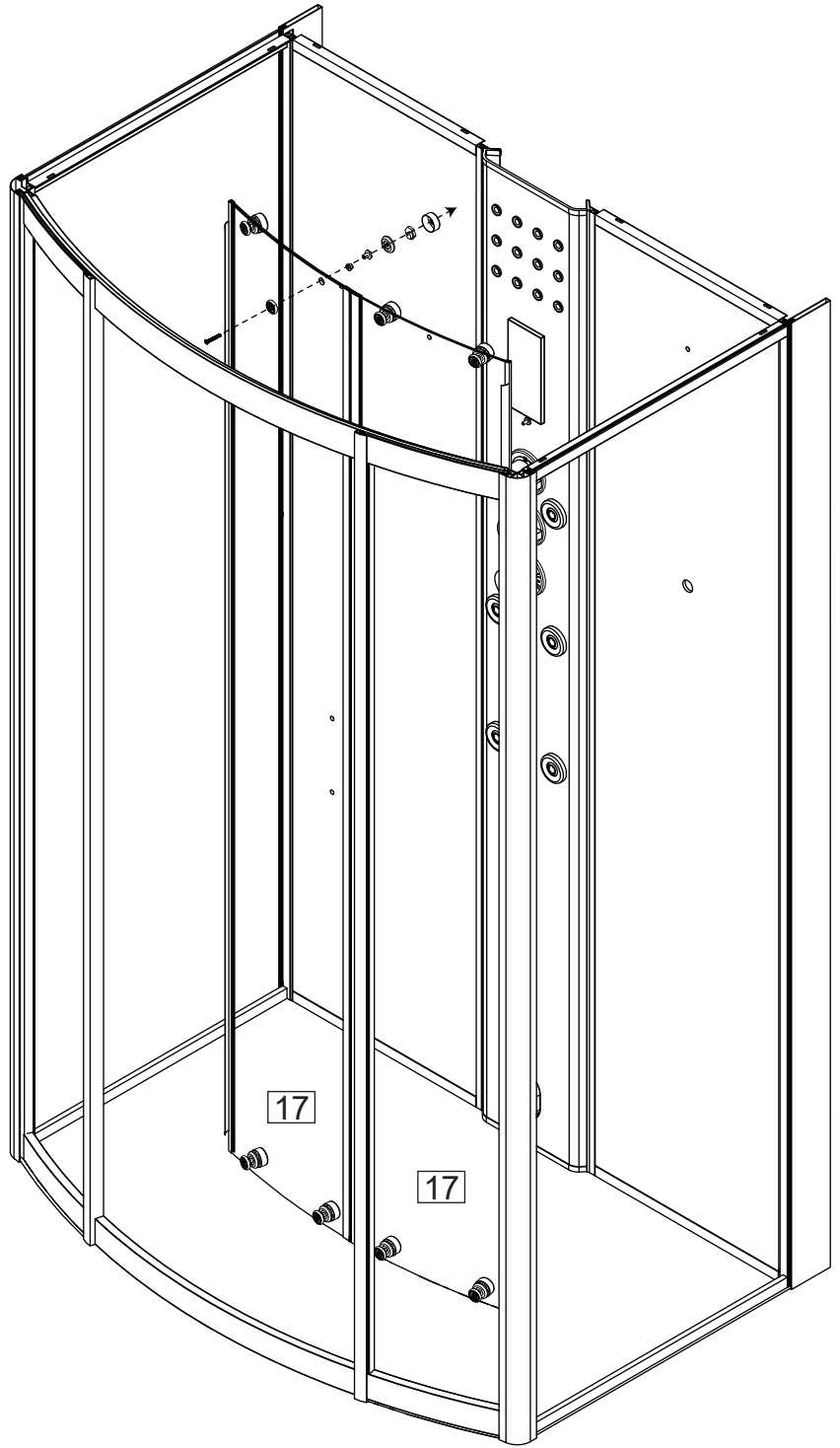
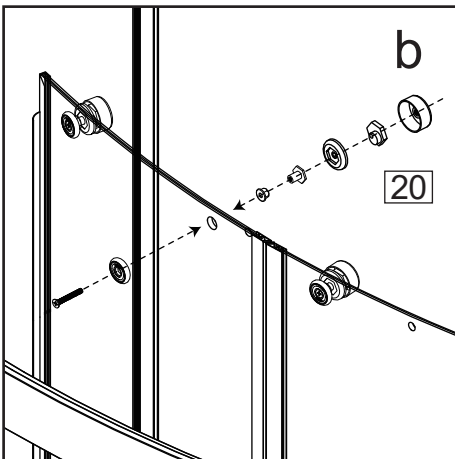
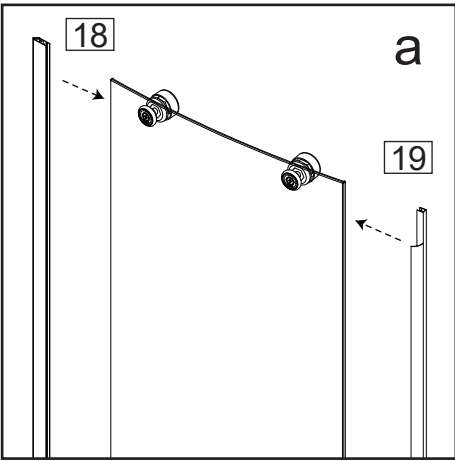
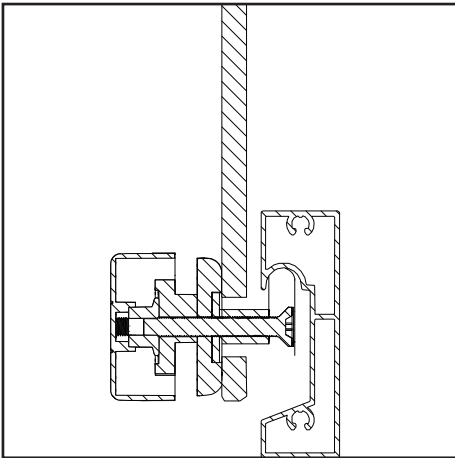
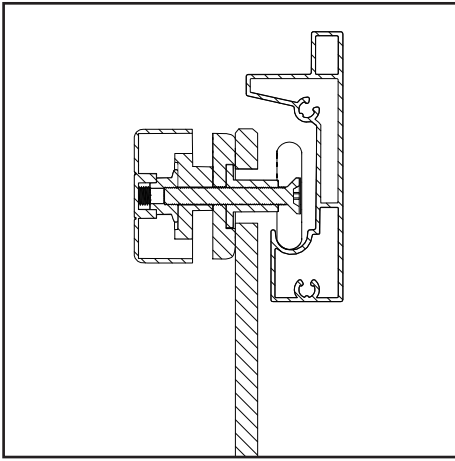

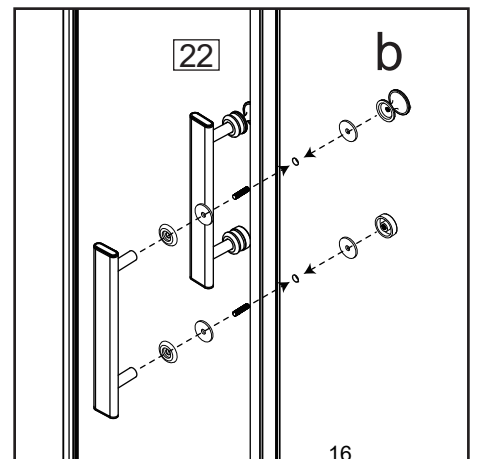
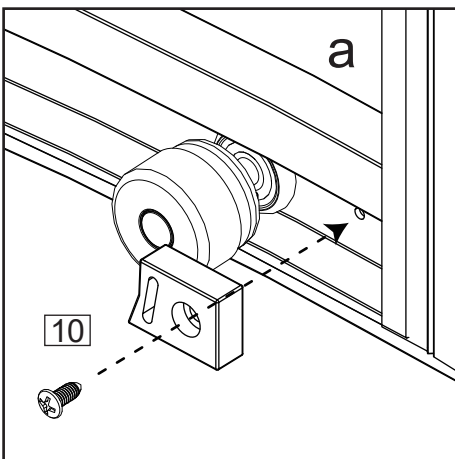
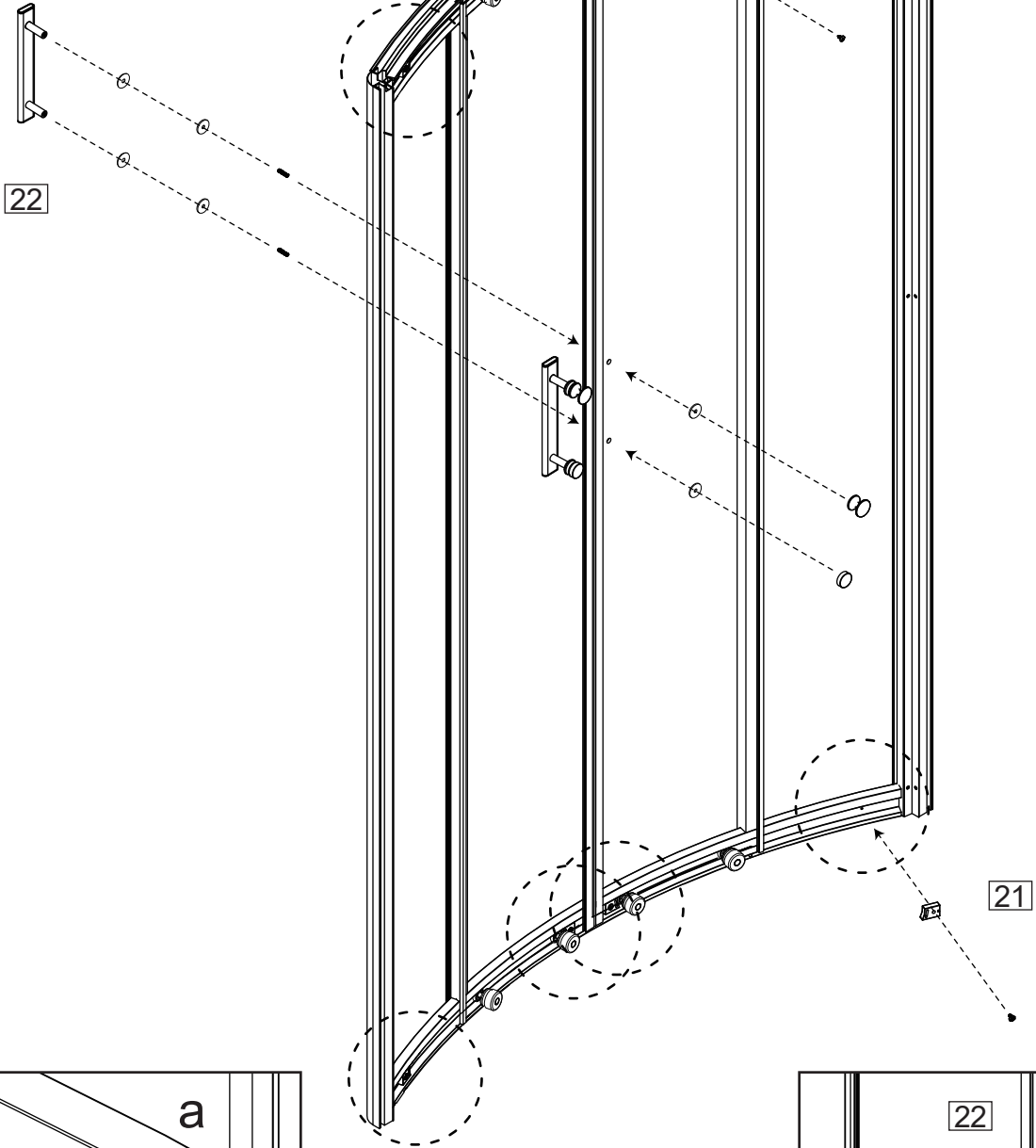
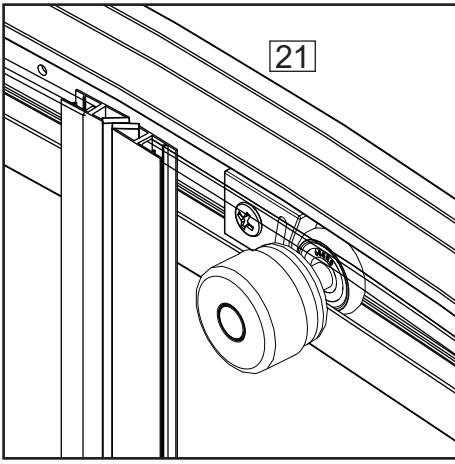

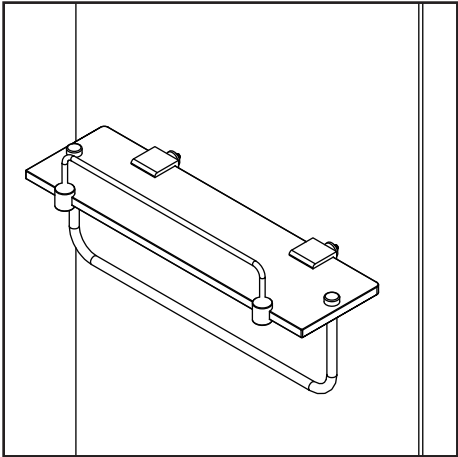

23

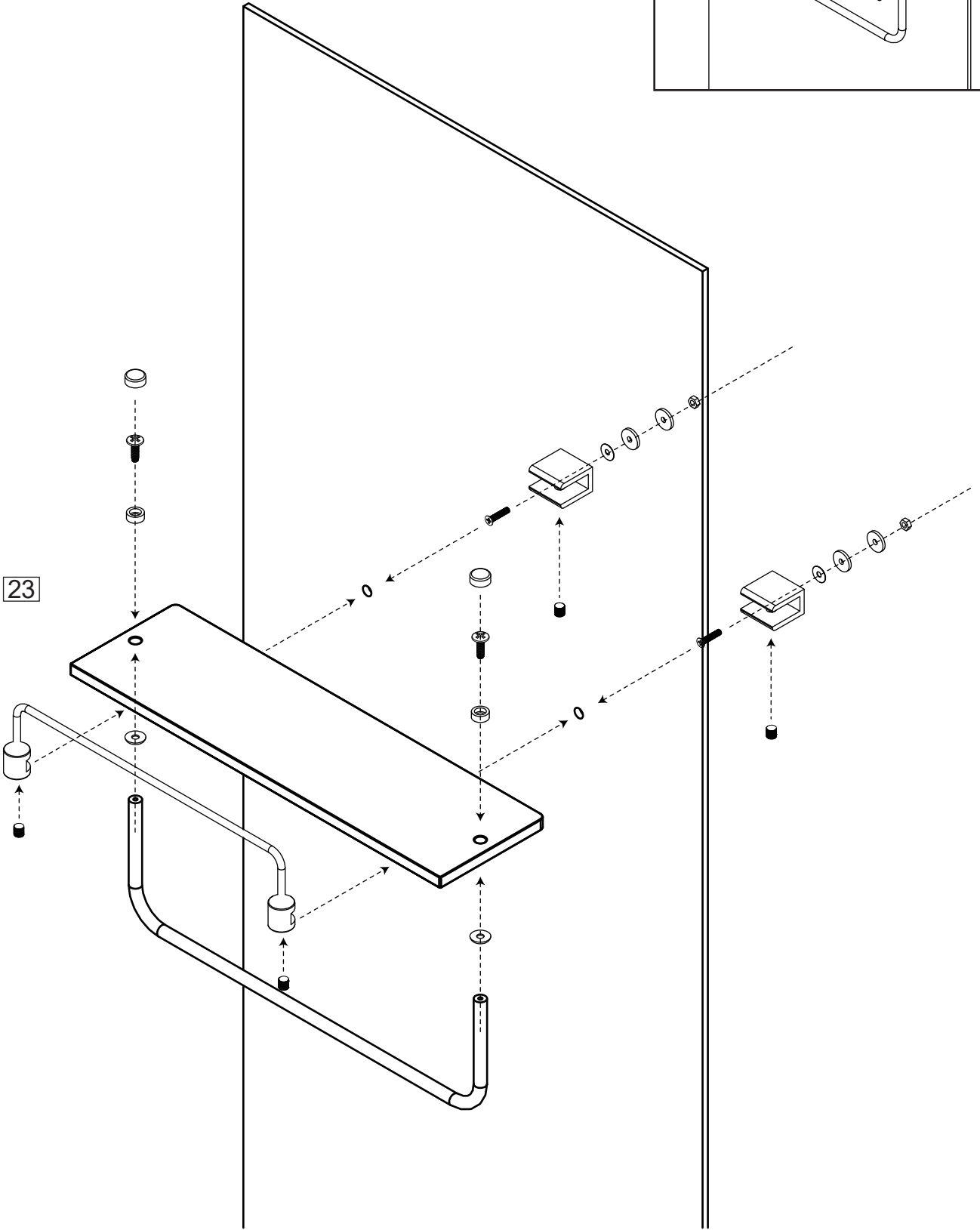

LEVELING AND FITTING THE TRAY

Remove the protective film covering the base.

Connect the soil pipe, trap and any couplings to the flexible waste under the tub. You may choose to fit either a HEPV0 trap with the appropriate couplings or choose to fit a McAlpine ST28M coupling to a McAlpine 28-NRV trap.

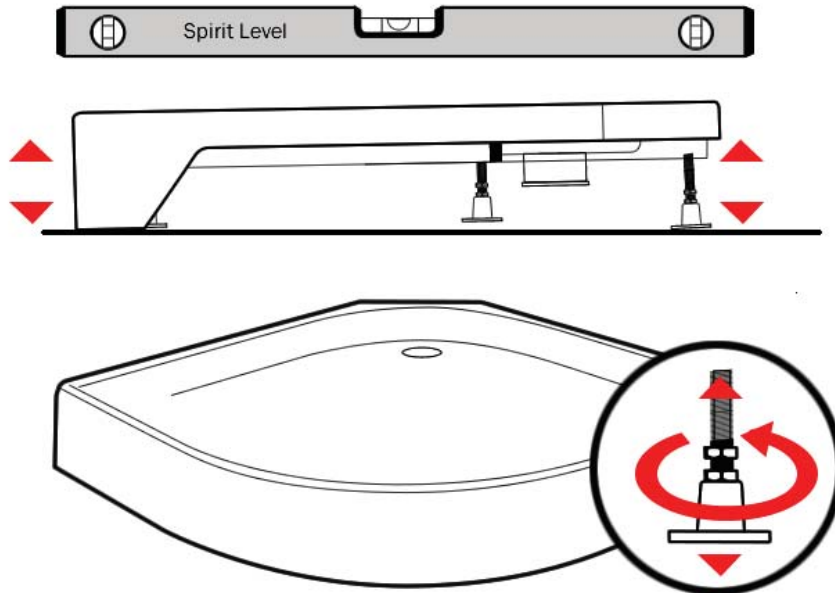

Position the tub base in what will be its final location and adjust the feet until the base is level. You can raise/lower the feet under the tub and with a spirit level laid across the tub, ensure the tub is level.

Now fill the base with some water and check that the water flows adequately to the plug and exits satisfactorily. If the water does not flow to the plug fully, then you will need to increase the fall on the tray by adjusting the legs. If the water does not exit the waste section fast enough, then ensure there is suitable fall in the waste pipe and/or no blockage or kinks in the pipe work.

Check and attend to any leaks.

Now slide the tub away from the wall to allow access all around the shower as you assemble.

This product is freestanding so you do not need to fix the feet to the floor.

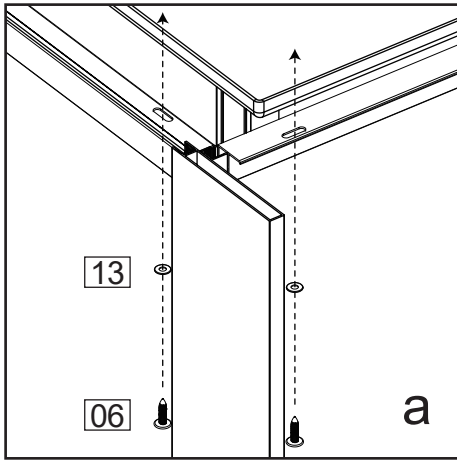

Run a bead of sealant along the tray where the panels will sit to provide a watertight barrier.

Remember to remove any excess sealant once the panels have been seated into position.

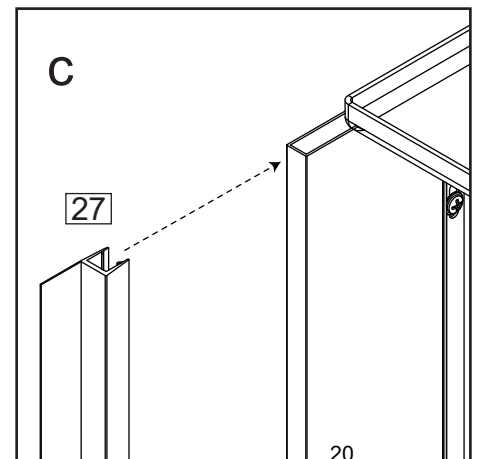
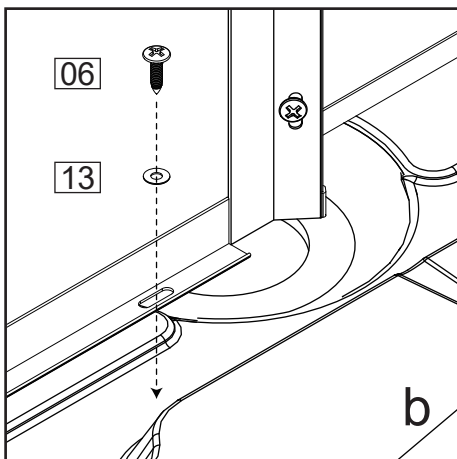
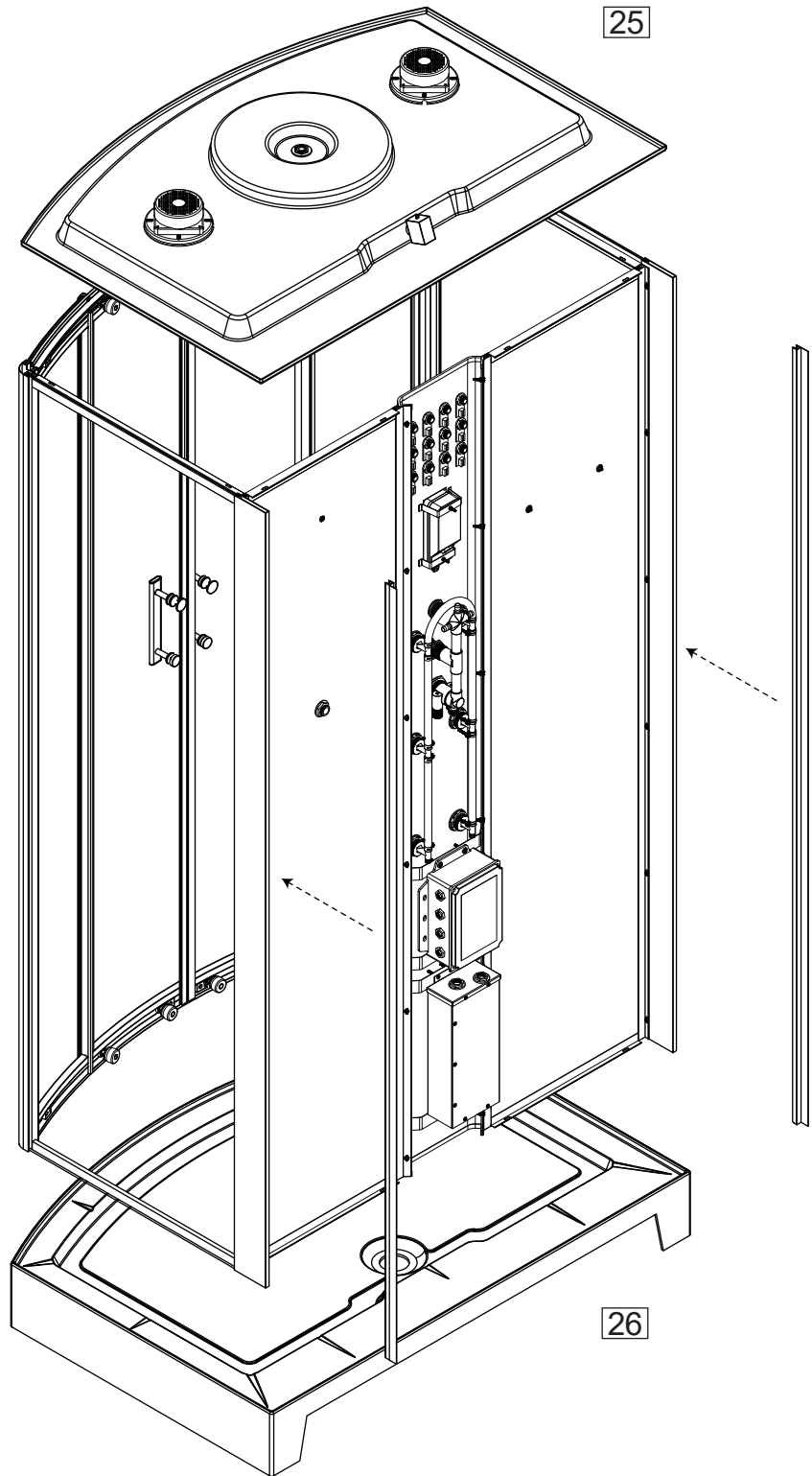

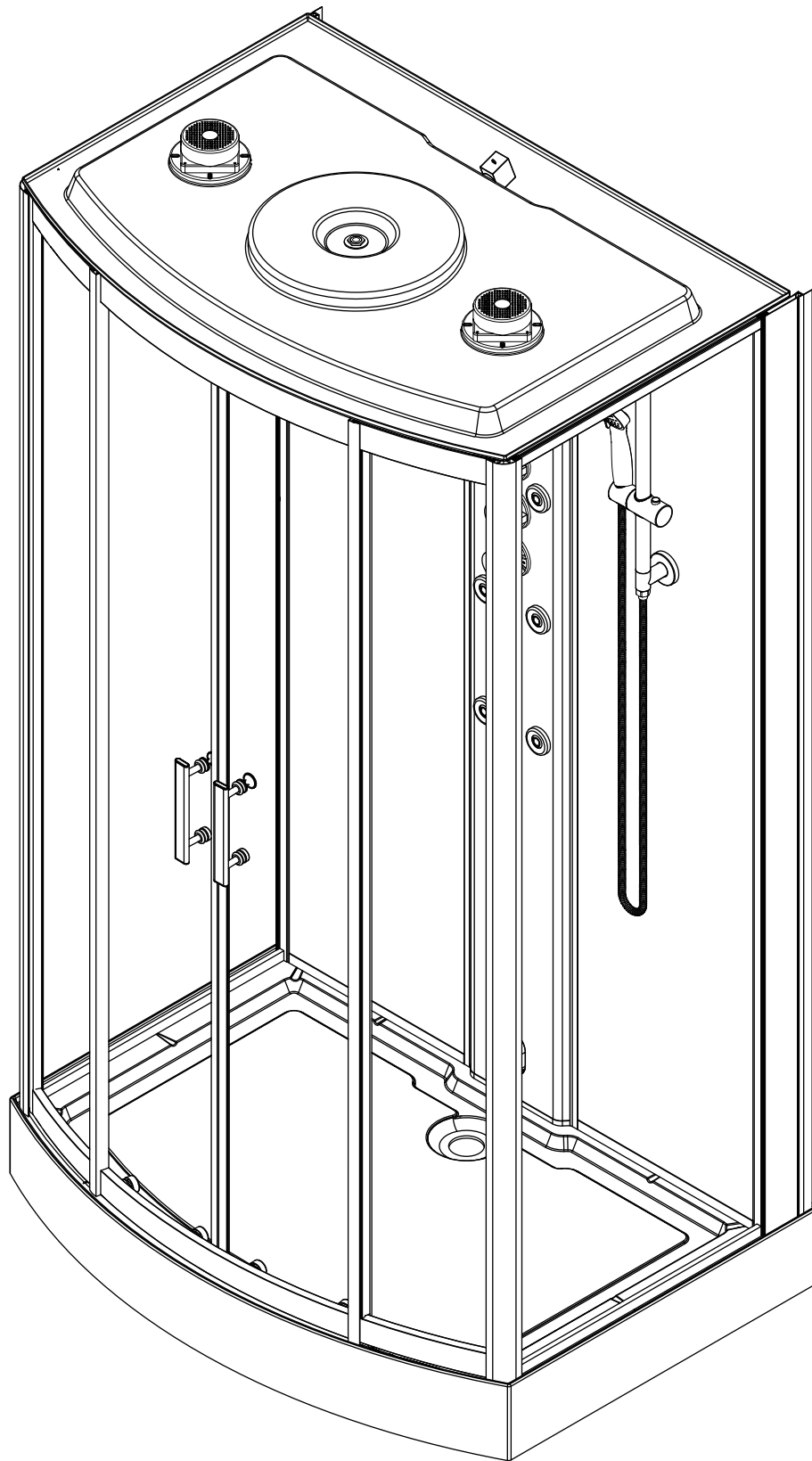

Water Connections

This product requires a hot and cold water supply. Your Hot and Cold water supply pipes should ideally be finished about 1 meter above the floor centrally in the corner and finished with 15mm compression isolating valve. The shower will require two braided flexible hoses that connect to these water supply pipes from the shower valve.

WATER PRESSURE: 1-3 bar (ideally above 2 for optimum results)

WATER FLOW: above 7.5 litres per minute

Important Note Do not exceed 3.4 BAR pressure under any circumstances. Warranty is void if so as damage will occur. If you have a combi supply, please use a pressure reducing valve if required to lower the BAR pressure to the shower.

Fitting Isolating valves is recommended as this makes service access easier than locating the house Stop Cock. Additionally Isolating valve enable you to disconnect water to the shower if you are away from home for long periods of time.

Combination boiler installation and PEV's

This product does not normally require a Pressure Equalising Valve (PEV) as it uses the latest generation of shower valve Thermostatic Cartridge, which enables it to handle un-balanced water pressures itself, to provide accurate temperature control.

This shower product can be connected to Combi Boiler system that provide suitable water pressure and water flow rates.

Gravity Fed and Shower Pumps

Where the water is supplied by a hot water cylinder (gravity fed type systems) a shower pump should be installed. Ideally a shower pump rated over 2 bar supplying just the shower is recommended, or alternatively a pump of higher specification can be fitted to supply multiple showers within the property.

When choosing a pump, a twin impeller pump is recommended as this will ensure both the hot and cold water is of the same pressure. (You must seek further advise from a plumber to correctly spec the right shower pummp for your set-up

Always refer to the manufacturers instructions regarding shower pump installations and choose the correct type for your particular situation (negative head/positive head etc). All pipe work between the storage tank, cylinder and to the pump should be 22mm and the shower positioned at least 250mm below the header tank. Please note that locating the pump further from the shower and cylinder may reduce the effectiveness of the pump and will certainly reduce the output pressure of water.

Ensure the pump is correctly installed and commissioned. Failure to fit the pump in accordance with the manufactures instructions may result in inadequate water supplies and lead to pump pulsing etc.

Maximum pressure: The shower requires water pressure up to but not exceeding 3 bar. Exceeding this maximum rating may damage the product and will invalidate your Guarantee.



CHECK ALL WATER CONNECTIONS ARE WATERTIGHT. PREFITTED CONNECTIONS MAY ONLY BE MADE HAND TIGHT AT MANUFACTURE AND/OR MAY WORK LOOSE IN TRANSIT

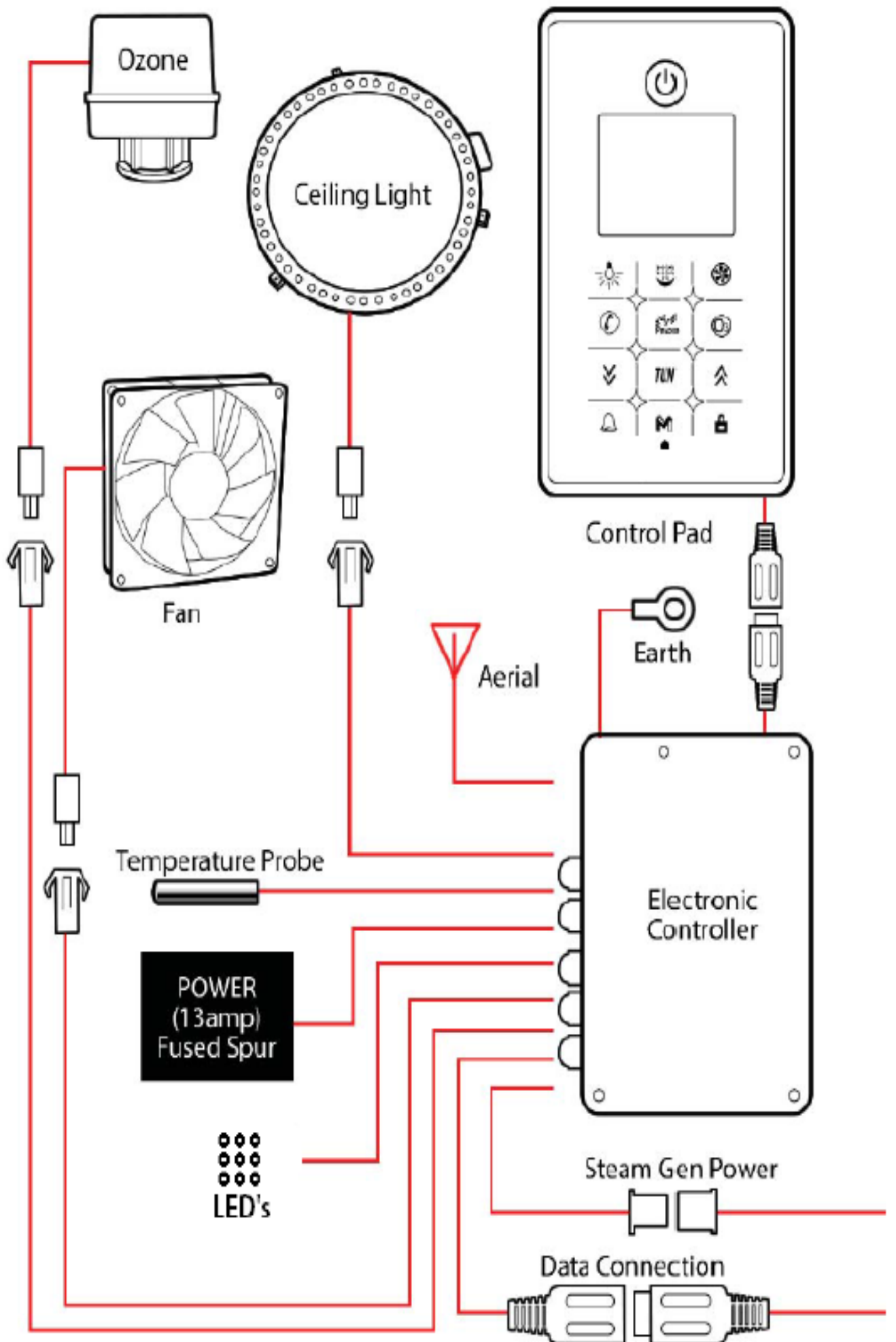

Steam Version Shown

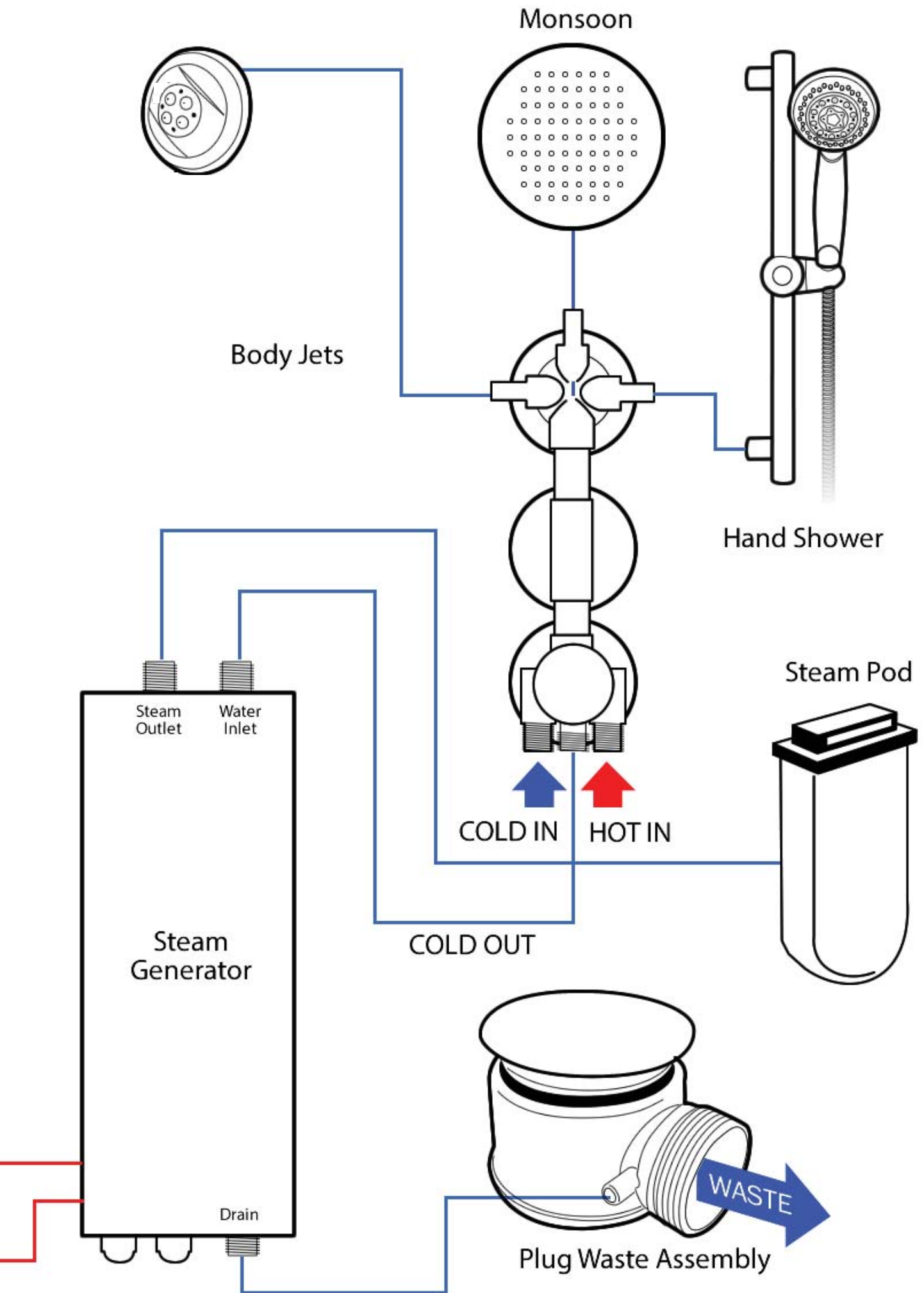

Steam Only Model Connections

Steam Shower Version

This Steam Shower requires connections to MAINS ELECTRICITY. 1 x 13amp

RCD (Residual Current Device)

This shower product also comes pre-fitted with an RCD. This device provides safety cut of in case of an electrical fault.

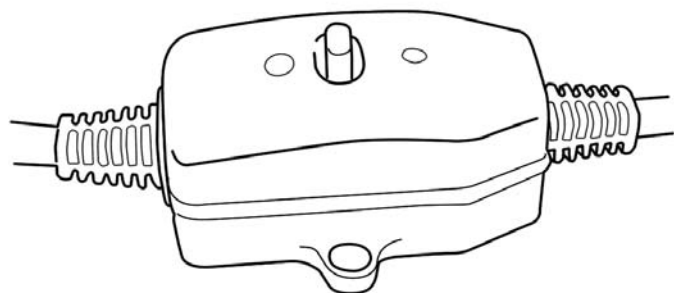

STEAM GENERATOR & ELECTRONIC CONTROL UNIT

This model has a separate Steam Generator and Electronic Control Unit. Both parts have a Data Cable to provide electrical communication between each part and a Power transfer connection. Make these connections and ensure they are secure.

If the Main Board (Consumer Unit) in the property is already RCD protected you **MUST** remove the one fitted to this product.

Hydro none Steam Model

The shower is supplied with a 12 volt transformer that needs connecting to the mains
The plug should be left in place and plugged directly into a socket that is in a suitable IP rated zone

DO NOT CUT THE WIRE OR REMOVE THE PLUG

All Model Connections

ELECTRONIC CONTROL PANEL

The Shower has an electronic control panel to allow you to operate and control the steam production, lights, radio and audio system. Locate the communication cable coming from the panel at the rear of the shower and connect it to the corresponding cable that will be found coming from the electric control unit. This connection uses a series of small pins inside, **CARE MUST BE TAKEN MAKING THIS CONNECTION** to not bend the pins. The plugs are marked with an ARROW to identify which way they connect.

You MUST ensure all electrical work is carried out in accordance with current Legal requirements.

CONNECTING LIGHTS, FAN, OZONE Etc

Each component needs to be connected to the Electronic Control Unit. Each component (Fan, Ozone, Speaker etc) has a thin 12v cable with a plug on the end. You will also see that each cable has a sticker with an Icon to indicate what it is. The electronic control unit behind the showers central tower panel has a large number of cables. Again, each of these cables has a similar plug and a label corresponding to those of the Fan, Ozone, Lights etc. Match each item and make the connection securely.

AERIAL

Position the Radio aerial wire in a position that allows the radio to receive the best possible signal. Note that local interference from Taxis, Ham Radio, Emergency Service, Hospitals etc may affect reception.

Sealing the Shower

OPTIONAL:

Under normal use, the shower will return all water back into the tray. Should you choose, we recommend that you seal the shower internally with a good quality bathroom sealant to provide an extra level of water proofing.

All sealant placed on the inside of the shower with a good quality 'Anti-Moulding' Sealant.

After allowing the sealant to set (as per the sealant directions), move on to the water test and check for signs of water leaking, please attend to them as required.

Water Testing

This is an important step to complete the shower. You should test all fittings and fixtures of the shower to ensure the shower is fit for use.

Items such as, but not exclusive to, the connections for example are connect prior to delivery for illustration purposes ONLY and will not be water tight and further can become more loose during transit.

You should treat all connections and fittings as such and fully ensure all connections are complete and ready to be used

You should run and completely test all fixtures and features on the shower, as well as its water integrity to the level of normal use until you are confident of its completion

PLEASE NOTE:

The shower is made up of solid parts (glass, metal, Acrylic) Any leaks found during testing will be down to incorrect installation/sealing - you should spend a good amount of time water testing the shower before 'signing it off' with the customer to avoid returning

Due to the design of the shower, no excessive silicone should be on display. This means that with normal use and cleaning, there will not be any escape of over the trays edge and on to the bathroom floor. There will be areas on the shower where water will pass and escape to the shower tray, however this will travel around the tray and return via the water channels back into the shower.

There might be areas on the shower, like corners or gaps that during normal showering are subjected only to sustainable amounts of water. These areas when sprayed directly and heavily with the shower head in a fashion thats inconsistent to showering, may overwhelm the shower tray lip and return channels allowing water on to the bathroom floor. We guarantee our showers will not leak during regular showering use/practices without any silicone on show.

However, if you wish to obtain a further level of security you can do so by adding the sealant. You should water test and add where required as you test to gauge the level of sealing required to meet your requirement

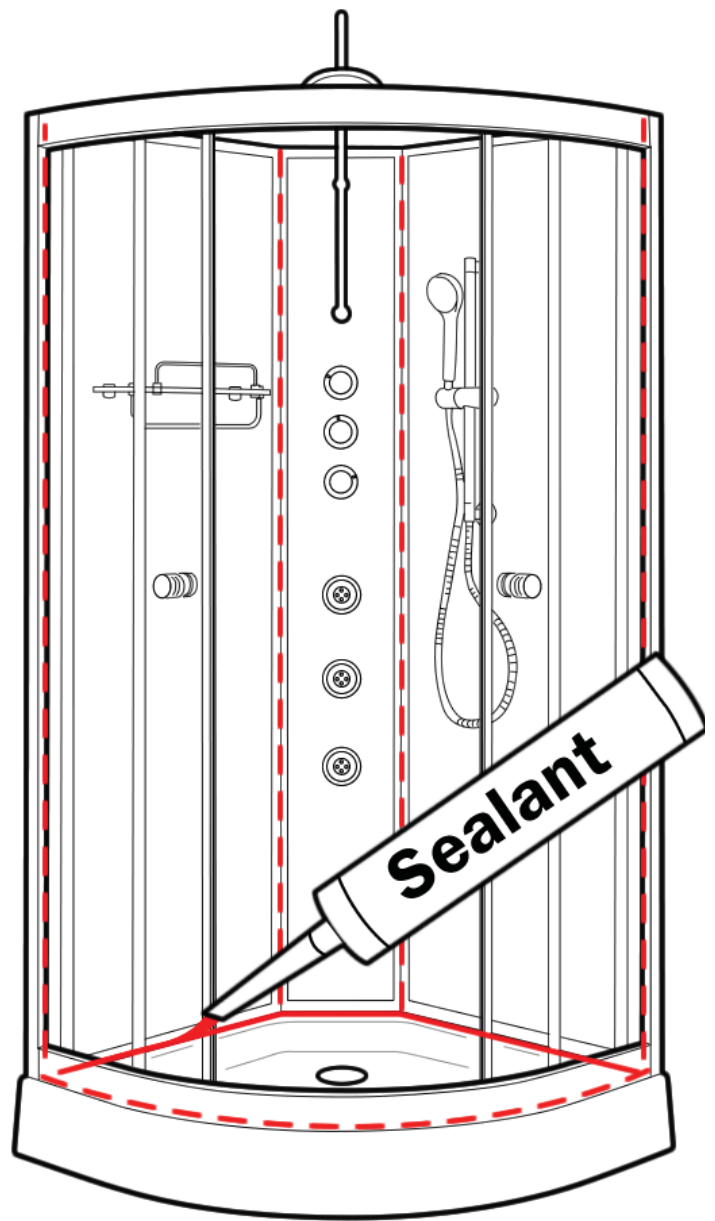

DO NOT PUT SEALANT INTO THE WATER RETURN CHANNELS

Final Testing

Check and test that each outlet function (hand shower, body jets and monsoon) work as expected by rotating the DIVERTOR DIAL (top chrome dial).

Check the ON/OFF dial enables the water to be fully on or off in the position indicated on the valve markings.

Check the Temperature can be increased and decreased by turning the lower chrome shower valve dial. Test that the button can be pressed at 38 degrees to turn the dial to the hottest settings.

Check the water runs to the waste/plug efficiently. A small amount remaining in the tray is normal.

FAULT FINDING

Water does not exit tray fast enough.

The tray must be leveled and a suitable 'fall' on the tray that enable the water to run to the plug. Additionally, the waste hose (under the tray) should have suitable fall to allow water to exit quickly.

Water pressure / flow is low on some or all shower options.

Check all the hoses are not trapped or kinked and thus restricting flow. Check also that any washers are not out of position and restricting flow. Ensure you have OVER 7.5 litres per minute flow and over 2 bar water pressure.

Water is 'pulsing'.

If a pump has been used to supply water under pressure and the back jets, or hand shower cause the pump to start and stop (PULSING WATER), remove the NON RETURN VALVES. Remove the Braided hoses at the rear of the shower. Look inside the valve where the hoses connected and you will see a silver coloured 'C' clip. Remove this and this will enable the NRV to be removed (white plastic item). Refit the hoses and re-test. Pulsing may also be noted where a pump has not been fully commissioned and there is air in the system.

Doors do not meet correctly and or bind when opening or closing.

Adjust the door runner cam wheels correctly to enable smooth running and operation.

Water is leaking out of the shower.

Dry the shower fully. Once dry, turn on the shower and operate the functions and look for where the water is leaking from. Apply sealant to the area where the water is leaking from.

The shower temperature is low.

If the water in the rest of the house is at a suitable temperature, then you may need to replace the thermostatic cartridge. Limescale or other dirt can impair the function of the cartridge.

For more help with your shower, please call, our technical team will be on hand to help.

Valve Operation

There are 3 control dials inside your Shower Cabin. These dials control the output functions, water flow and temperature of your shower.

The top dial can be turned to allow you to choose which output you wish to use: Body Jets, Overhead (Monsoon) Shower and Hand Shower. Turn the dial to the required output, there will be an audible click as the selection is made. Do not turn the dial when water is flowing as this will decrease the life of the selector mechanism.

The middle dial adjusts the water flow rate. The dial rotates though 90 degrees. This dial also acts as the on/off for water flow.

The lower dial controls the temperature. The dial rotates from 20 degrees to 38 degrees and then will stop. This is a safety feature. To enable temperatures higher than 38 degrees, simply press the knob on the dial in (toward the main dial) and then turn the dial past the 38 degree mark.

Turning the temperature dial past 30 degrees **MUST** be done with care to prevent scaling.

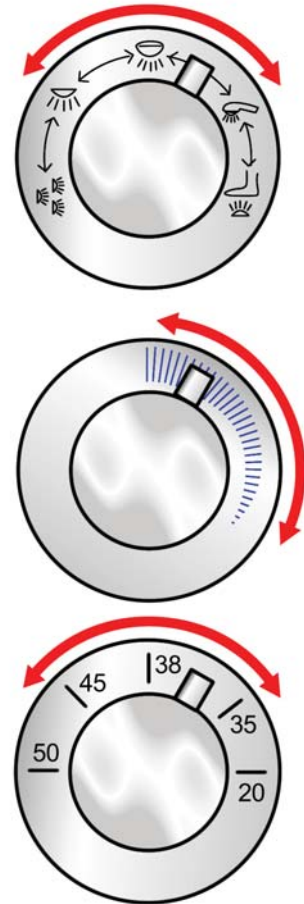

Safety Precautions

On models fitted with Steam functions, it is normal for the steam generator to get quite hot during use. Please allow up to half an hour for the generator to cool before touching associated areas including the steam pod.

Always disconnect or isolate the water supply to the shower before commencing any investigations, service or replacement of parts. Where the product has electrical power, this should also be turned off.

Children should NOT use the shower unless under strict adult supervision.

All products are single person occupancy unless otherwise sold as twin person.

The tray surface inside the product can become slippery especially if soap, gel or shampoo is on the surface, we therefore advise care when stepping in, out and during use.

Electronic Control Panel

Your steam shower is fitted with an electronic control panel that allows you to operate the electronic features of your shower.

From the control panel you can control the lights, Steam, Radio and Bluetooth audio.



Power ON / OFF



LIGHTS

This model comes with an LED 'Halo' ring light surrounding the monsoon. Press the light button once and both the top light and LED's come on in white. A second press turns the LED's off and starts the top light cycle. Press for a third time to stop the top light on current colour. Toggle for a fourth time to turn the light off.



STEAM (Steam Version Only)

Pressing the Steam button activates the steam Generator.

Press the SET button to toggle between the Temperature and Duration/Time settings. Temperature is the setting the cabin will try to maintain inside the cabin and duration is the length of time you plan to use the steam. Do NOT use the steam function for longer than 15 minutes in a session, allowing to fully cool before re-use.

SET

When the radio function is in use. Pressing the set button for a third and fourth time brings up the volume and channels where once tuned you hit the 'M' button to save the station you are on the the current chanel



RADIO

This button activates the built in FM Radio. Once in this mode the left and right keys can be used to browse stations and channels as well as increasing and decreasing volume



BLUETOOTH

Pressing this button will allow you to receive audio played from Bluetooth enabled device. You can control skip tracks as from the left and right arrows . You will have to PAIR the shower to a bluetooth device first



REMOVE PROTECTIVE FILM ON CONTROL PANEL BEFORE USE



FAN

The circulation fan can be activated to draw air/ steam inside the cabin out. This may be used in conjunction with the steam.



ARROWS

The Arrow buttons control Tuning, Volume, Track Skip etc depending upon which mode is currently selected.

PHONE

Use this button to answer calls whilst connected to bluetooth



M

The button can be used to Store Radio stations into Memory. The button also serves as a toggle the function of the ARROW keys for time/ temperature/track/volume/tuning etc.

OZONE (Steam Version Only)

This is a silent function and turns on automatically when the unit is powered down. Leave the shower to carryout the process which takes approximately 10 minutes. then open the doors and allow the shower to fully air dry. This device does not make any audible or visual notification other then the panel display, but the aroma of Ozone may be noticeable when you open the doors.

Bluetooth Pairing

Before you can start streaming Audio to your shower you must first establish a connection between the shower and the device that will stream the audio to the shower; this is called Pairing. You can stream up to 10 meters away, depending upon interference of walls etc.

Most devices that are Bluetooth Audio Streaming enabled can be connected to the shower, such as Smart Phones (Android, iPhone etc), Tablets (Galaxy Tab, iPad etc) and even computers and Laptops.

- 1: Press the BLUETOOTH Button on the control pad. The display will now say BT.
- 2: On your Smartphone/Tablet etc, go to the Bluetooth settings (If unsure, refer to your manual for more information on how to access this)
- 3: Ensure Bluetooth is active/running on your device.
- 4: Initiate a SEARCH/SCAN for New Devices to Pair to.

5: After a small amount of time you should see the device name of the shower appear " SJ-02". Select this to complete the Pairing of the two devices.

You are now ready to stream audio. Go to your music playing App, choose a track and press play.

Once Paired you can stream music at any time to the shower. Only once device can be Paired at any time.

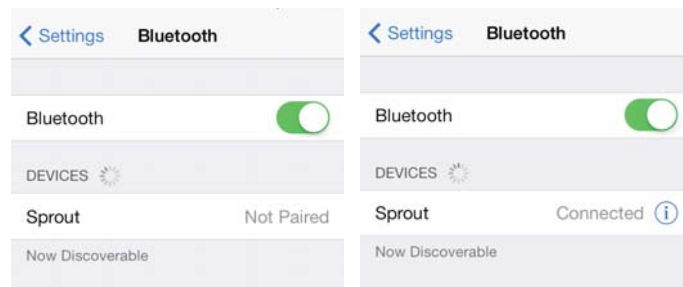

Due to the various different number of devices that have Bluetooth, and the variations on the implementation of Bluetooth enabled in your device we are unable to guarantee connectivity or to provide support for connecting, however the product has been tested on a number of Apple and Android Tablets and Phones with complete success.

Cleaning and third party product use

DO NOT CLEAN BY SPRAYING THE HAND SHOWER DIRECTLY INTO AREAS THAT MAY PASS WATER - UNLESS YOU HAVE ADDED THE ADDITIONAL INTERNAL SILICONE IN PREVIOUS STEP

This shower should be cleaned after every use to remove the build up of dirt and bacteria. We would recommend that after normal showering use, that the cabin doors are left open until the inside is fully dry. This will help prevent the build up of soap scum, dirt and bacteria.

The shower cabin can trap dirt in gaps between joints of panels etc, which may require extra care and attention during cleaning. To minimise dirt build up between panels, the application of a bead of silicone sealant suitable for shower/bathroom use will fill the gap leaving a smooth finish and both stop dirt build up and offer an extra level of water tightness.

The shower cabin can be cleaned with any suitable cleaning solution that is not abrasive, and is recommended by its manufacturer for use on acrylic, chrome and glass surfaces as appropriate to the materials in the shower. Not all general bathroom cleaners are designed for use on some materials of this product. Harsh abrasive cleaners containing bleach or peroxide **MUST NOT** be used

DO NOT USE CIF OR OTHER ABRASIVE CLEANING PRODUCTS ON THIS SHOWER.

In hard-water areas, wash down the unit and remove the dirt periodically. Fitting a water filtration device is also advisable in areas where the water is likely to lead to a build up of minerals within the pipes and diverter assembly. Hard water WILL reduce the life of the Parts that come into contact with water, such as the Thermostatic Valve. Fitting water softening devices will prevent this.

Steam Pod

Where products are being used to infuse the steam in the steam pod, only products that are designed for such use should be used. The use of products not designed for infusing of steam may lead to damage to this product inducing but not exclusively, discoloration to the pod, tray base and or cabin walls. Products such as, but not exclusive to Olbas Oil is an example of this.

Essential Oils, whilst no noted damaging effects have ever been reported on the materials of the products, Essential oils can be aggressive toward rubbers and plastics when in direct contact. Damage such as cracking, crazing, discoloration, therefore are NOT covered by Guarantee where oils have been used.

Additional information and help

For more details on the installation of this shower, technical support, FAQ please call The Technical Helpline on 01524 489939

If you need a replacement part for your product, please call use the warranty claim form on our website together with your warranty registration details.

To find parts for your product after the Guarantee has expired, please send us an email

Thermostatic Cartridge

Your shower is fitted with a Thermostatic Cartridge. Should you need to remove or replace the cartridge for maintenance or replacement, follow the instructions below.

Q: I am having to turn the dial round as far as it will go to the hottest setting and the water is only just warm.

A: Your Thermostatic Cartridge has showed signs of failure. You will need to replace the Cartridge.

Q: Why did my Thermostatic Cartridge fail?

A: Hard Water areas will result in calcification, which will build up in the Cartridge. Other reasons might be age of the Cartridge or even dirt or debris collecting in the Cartridge from the pipes.

BEFORE STARTING ENSURE THAT THE WATER SUPPLIES ARE DISCONNECTED OR ISOLATED

It is imperative that the water supply to your shower is between 1 and 3 bar as exceeding this may damage the Thermostatic Cartridge.

First check behind the shower. On the bottom dial, is there a small screw in the valve body holding the thermostatic cartridge in place? If so, remove this and replace when finished

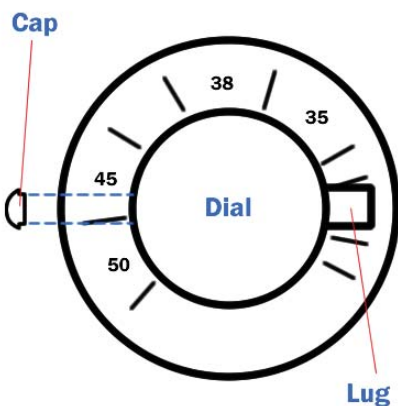

From inside the shower, on the lower of the three dials, remove the chrome coloured plastic cap that is fitted on the opposite side to the chrome lug.

The chrome cap will just pull off.

Keep the cap safe.

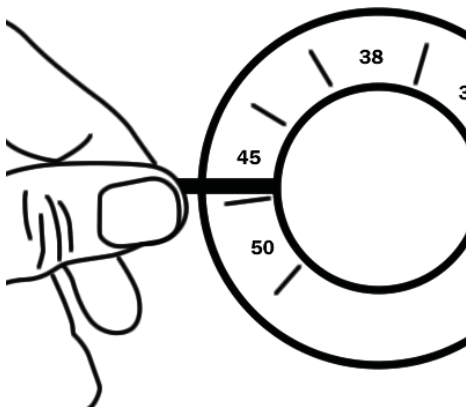

Using a 2.5mm Allen key, insert this into the hole where the chrome cap was fitted and loosen the grub screw about 1 turn to loosen.

DO NOT UNSCREW FULLY.

Now remove the chrome dial.

With the Chrome dial removed you will see a plastic ring covering with the Thermostat underneath.

Note down the position the ring is placed in.

Pull the plastic ring (Temperature safety lock) towards you to remove.

Keep this part safe

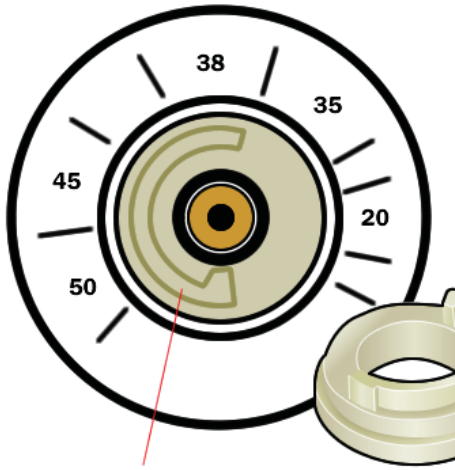

You will now see the head of the Thermostat clearly visible.

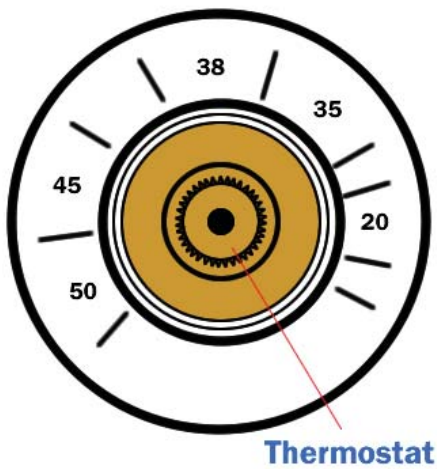

Thermostat

Turn the head of the cartridge counter-clockwise to remove.

To fit your new Thermostat, simple reverse this process.

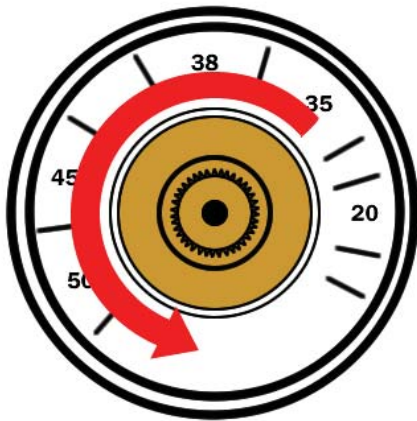

**FOR TECHNICAL
ASSISTANCE**

PLEASE CALL

01524 489939

Shower Completion Form

This form must be filled out by the plumber/installer and electrician (where applicable) in order to validate the warranty. You are required to register the warranty online at www.vidalux.co.uk

You MUST register the product warranty within 90 days following delivery

PLEASE RETAIN THIS CERTIFICATE FOR FUTURE REFERENCE

Shower Details

Model No.

Date Of Delivery

Invoice No.

Install Date

Install Information

Water Supply Type

Combi

Mega Flow/Pressurised

Pumped

Gravity Fed

**Cold Water Pressure
(LPM or BAR)**

**Hot Water Pressure
(LPM or BAR)**

PEV or PRV fitted?

PEV

Details

PRV

**Details of pressure
testing/flow rate
equipment used**

Plumbing Installation

Installer Name

Company

Address

Town/City

Post Code

Contact Tel

**Credentials/
Certificates held -
Reg number**

Signature

Date

Electric Installation

Installer Name

Company

Address

Town/City

Post Code

Contact Tel

Part P Reg No.

Date

Signature