

PARTS LIST

Your 6-Tier Metal Slat Shoe Rack should include the following parts. Please inspect box contents to ensure you have received all components.

If you are missing any parts, need assistance with assembly or have questions, please contact Customer Service.

You will NOT need additional tools for assembly.

A

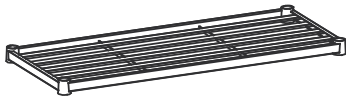

SHELF (6)

B

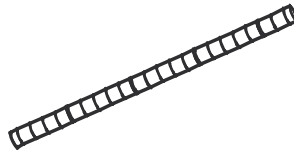

POLE (8)

C



THREADED INSERT (8)

D

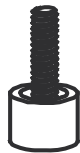

FEET LEVELER (8)

E



END CAP (8)

F



POLE CONNECTOR (4)

G



SLIP SLEEVE (48) + (2) extra

H

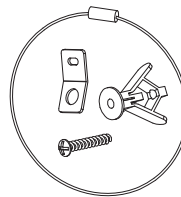

ANTI-TIPPING KIT (2)



Note: The black circular plastic spacers in between Shelves are used only for packaging purposes. They are NOT needed. Please discard.

ASSEMBLY OPTIONS

Option 1 6-Tier Shoe Rack

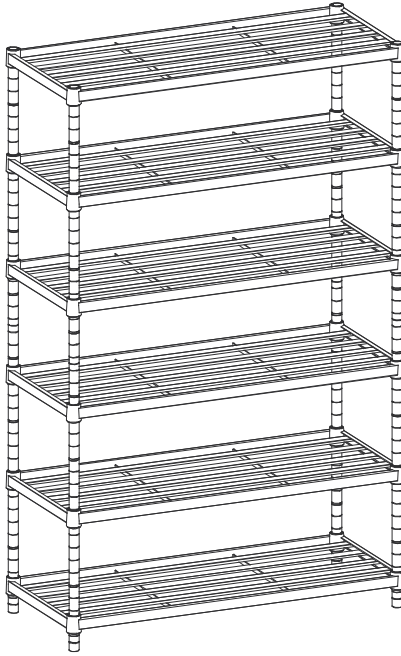

Option 2 (2) 3-Tier Shoe Racks

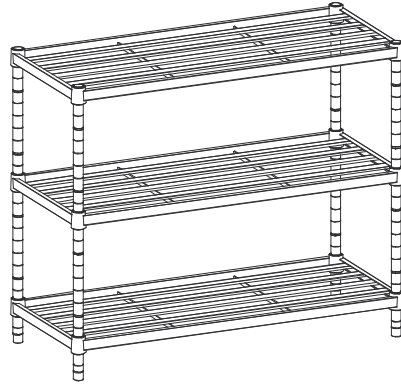
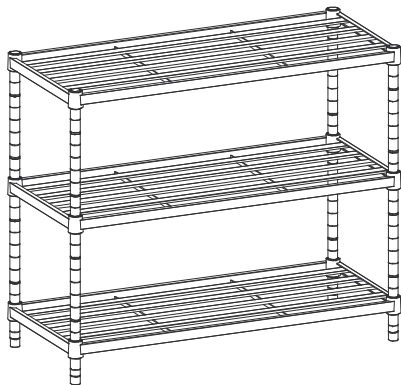

ASSEMBLY INSTRUCTIONS

Option 1 6-Tier Shoe Rack

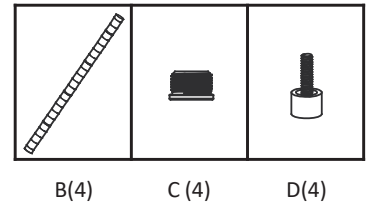

STEP 1

Take (4) THREADED INSERTS (C) and screw each into one end of POLE (B), turning clockwise to screw in place.

Take (4) FEET LEVELERS (D) and screw each into THREADED INSERT (C) that were screwed into POLE (B), turning clockwise to screw in place.

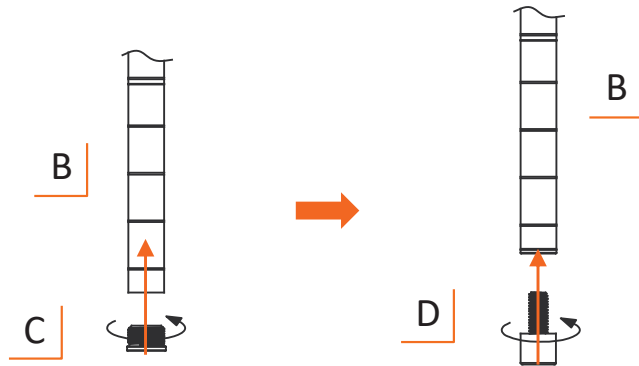

STEP 2

Note that POLES (B) have slight horizontal line indentations at 1" intervals. Each SLIP SLEEVE (G) has raised horizontal lines inside designed to lock them in place on POLES (B).

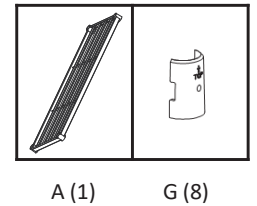

On POLE (B), place one pair of SLIP SLEEVES (G) at desired height **no higher** than 3rd indentation from bottom. Please make sure arrow faces up and word "TOP" is right side up. Slide pair of SLIP SLEEVES (G) until you hear a click to confirm pair is locked onto POLE (B). Do this for each POLE (B) and make sure height is identical for each POLE (B). Do NOT place more than one pair on each pole at a time.

Place SHELF (A) on its side and slide each assembled POLE (B) through each corner cylinder on SHELF (A). Make sure SHELF (A) corner cylinders are positioned over SLIP SLEEVES (G).

Stand the unit upright.

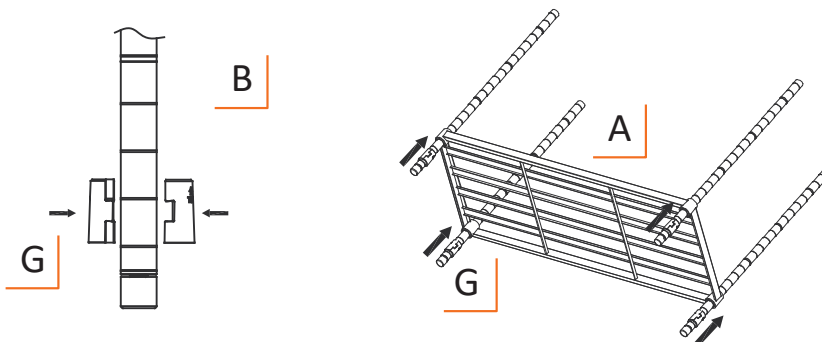

Note:

- Level side of SHELF (A) is TOP side.
- Use a rubber mallet, if needed, to secure SHELF (A).

ASSEMBLY INSTRUCTIONS

STEP 3

Repeat STEP 2, placing SLIP SLEEVES (G) on POLES (B) and assemble one more SHELF (A).

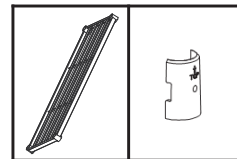

A (1)

G (8)

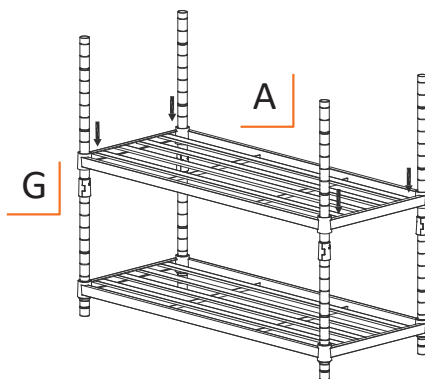

STEP 4

Screw each POLE CONNECTOR (F) into top of assembled POLE (B), turning clockwise to screw in place.

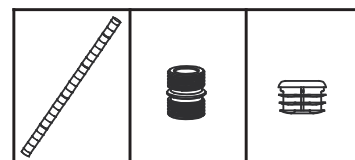

B(4)

F (4)

E (4)

Screw one unassembled POLE (B) clockwise onto POLE CONNECTOR (F). Repeat for other unassembled POLES (B).

As shown, take (4) END CAPS (E) and press each into top of POLE (B).

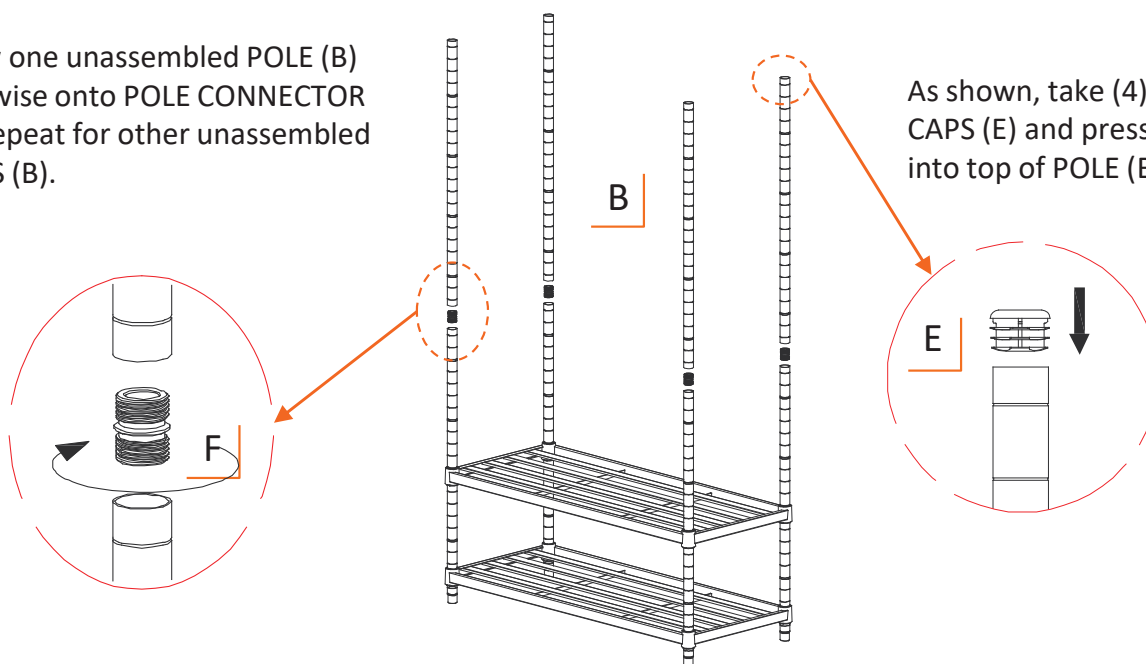

ASSEMBLY INSTRUCTIONS

STEP 5

Repeat STEP 2, placing SLIP SLEEVES (G) on POLES (B) and assemble (4) more SHELVES (A).

Note:

- Use a rubber mallet, if needed, to secure SHELF (A).

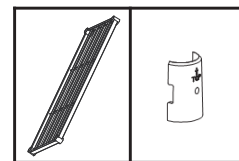
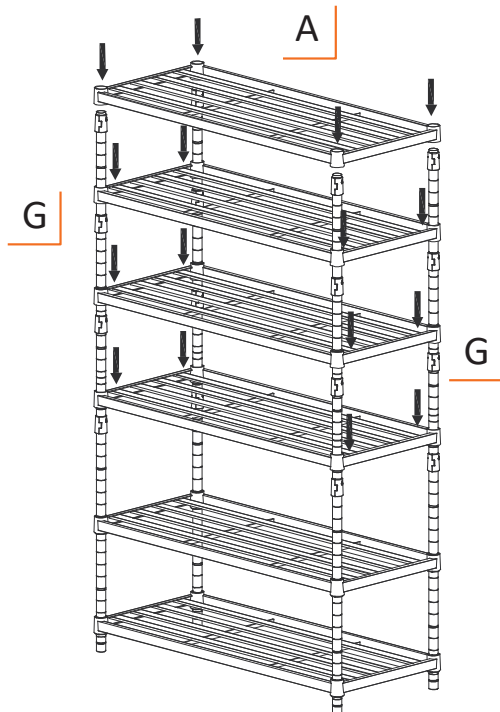

A (4)

G (32)

STEP 6

Place Shoe Rack by wall, drill 1 hole on each side of wall at same level of TOP SHELF (A) where ANTI-TIPPING KIT (H) will be placed.

Fasten ANTI-TIPPING KIT (H) to wall, loop cable through TOP SHELF (A) as shown, and close cable loop, connecting Shoe Rack to wall via ANTI-TIPPING KIT (H).

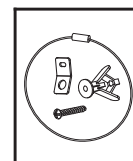
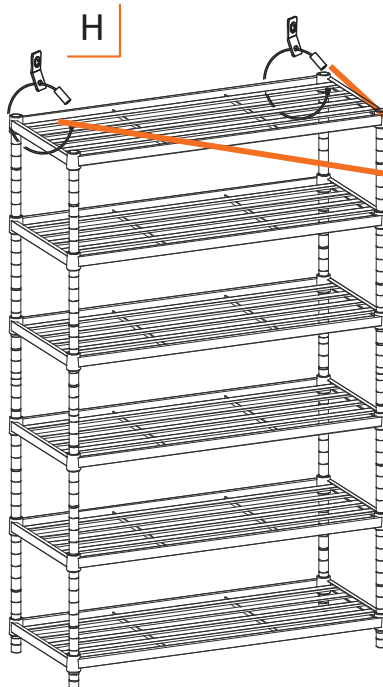

H (2)

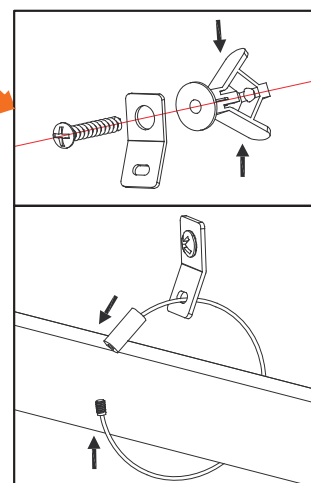

ASSEMBLY INSTRUCTIONS

Option 2 (2) 3-Tier Shoe Racks

Repeat STEP 1, 2 & 3 in Option 1

STEP 4

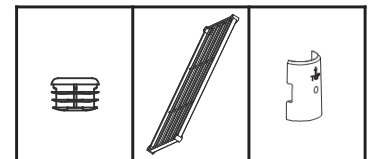

E (4)

A (1)

G (8)

Insert END CAP (E) into top of each assembled POLE (B).

Slide pair of SLIP SLEEVES (G) onto top indentation of each assembled POLE (B).
Place SHELF (A) corner cylinders onto SLIP SLEEVES (G) on POLES (B).

Repeat to assemble the other 3-Tier Shoe Rack.

Note:

- Use a rubber mallet, if needed, to secure SHELF (A).

