

SKU:SFBS2404003

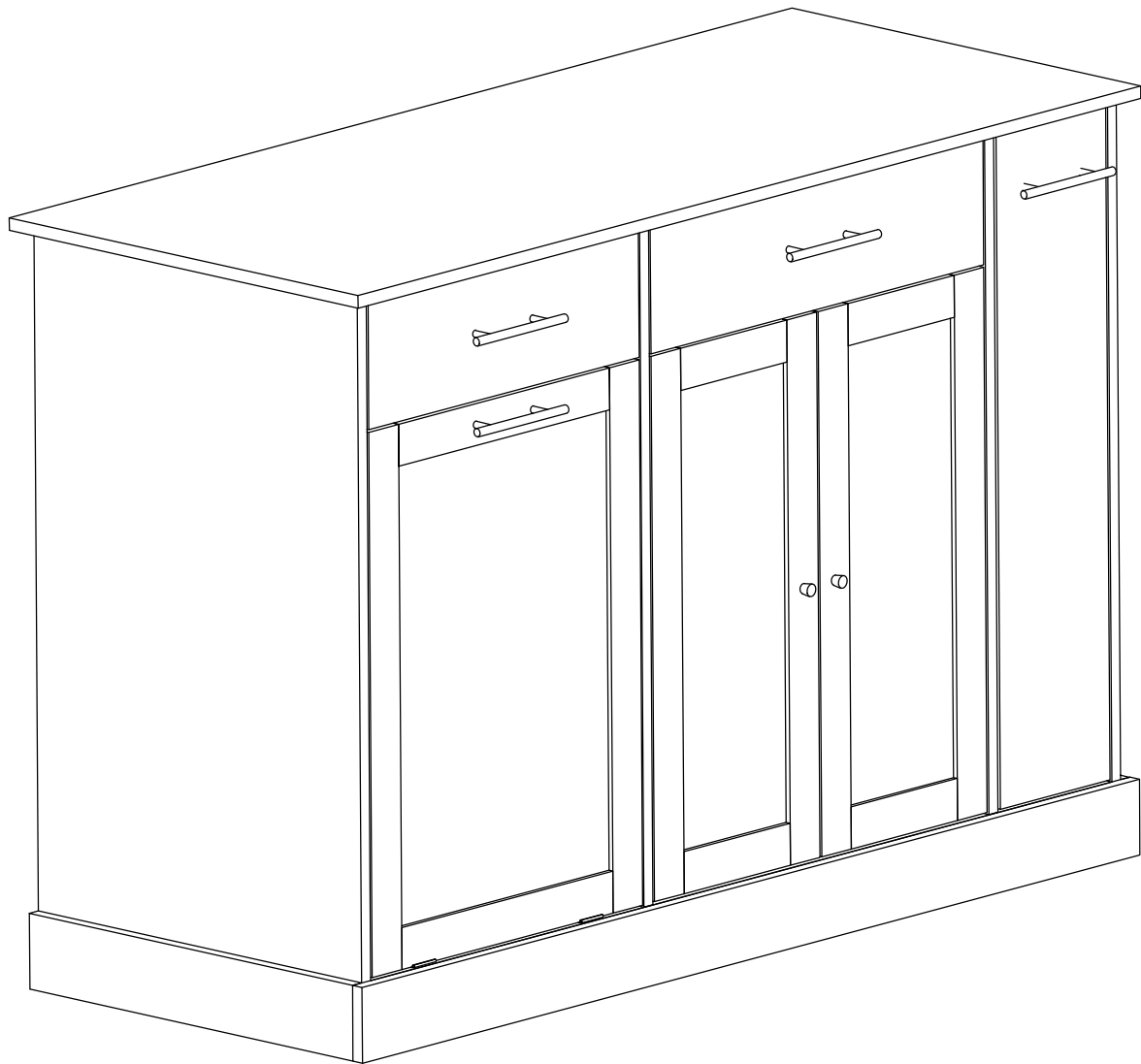

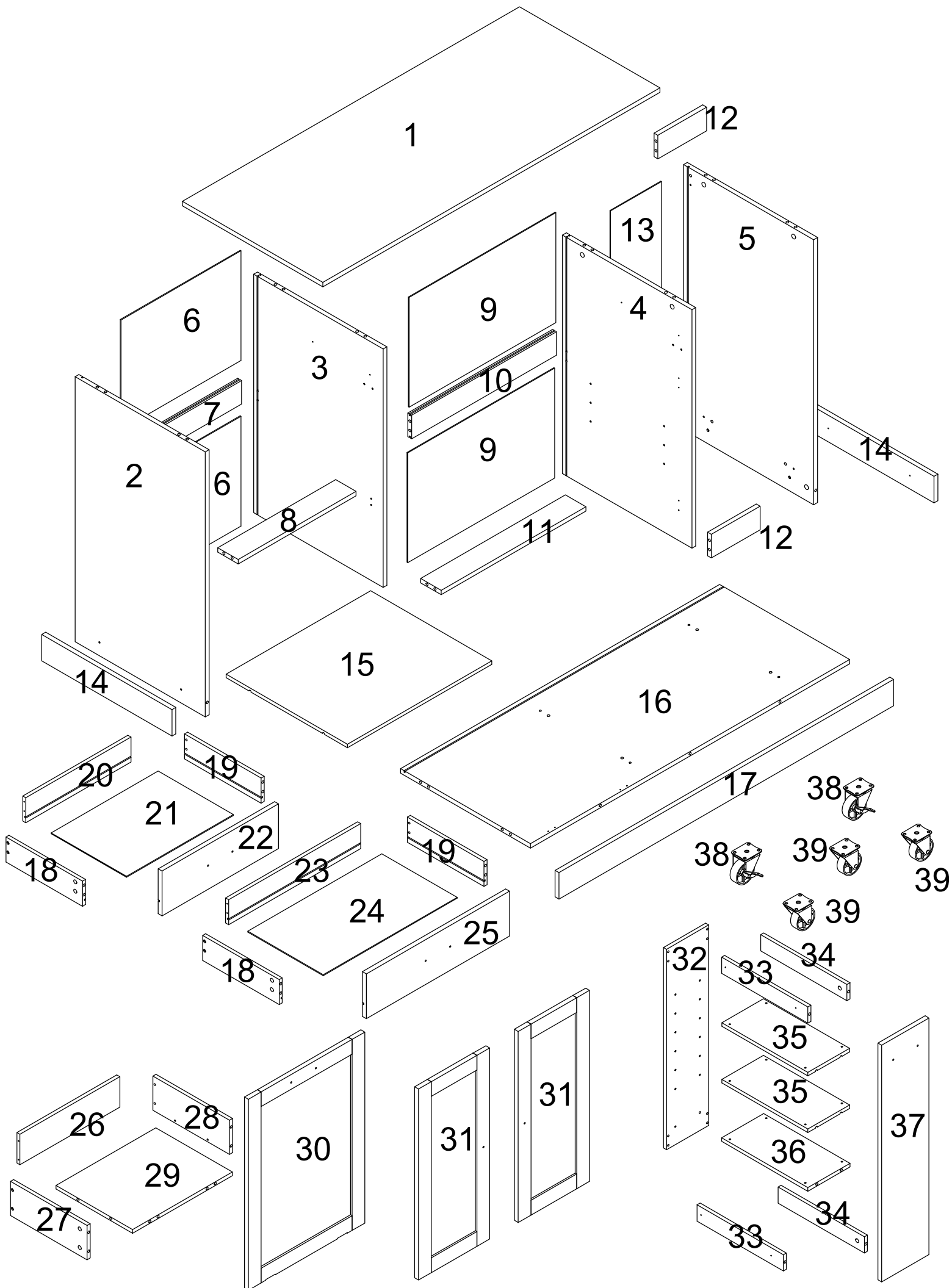

Trouble Shooting

Missing/Damaged pieces/
Wrong size and installation issues



Contact us with your problem, pic,
number and qty to the "Contact seller"
button in the detail page of your order



Respond with 24 hours to solve issue

Before You Start

1. Read through each step carefully and follow the proper order
2. Separate and count all your parts and hardware
3. Give yourself enough room for the assembly process
4. Caution: If using a power drill or power screwdriver for screwing, please be aware to slow down and stop when screw is tight. Failure to do so may result in stripping the screw

Cam Lock Fastening System

This Cam Lock Fastening System will be used throughout the assembly process

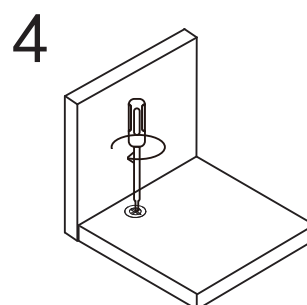
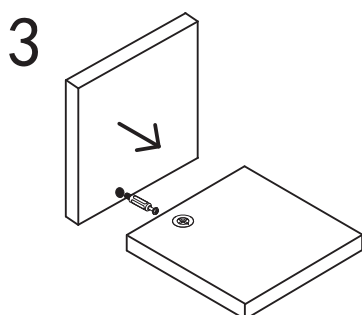
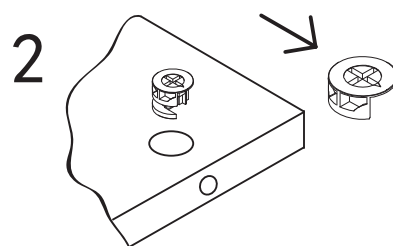

Parts List

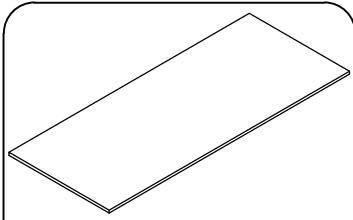

1

1PC

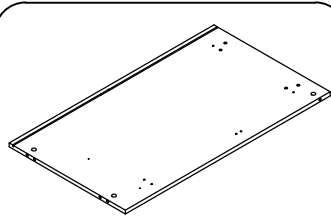

2

1PC

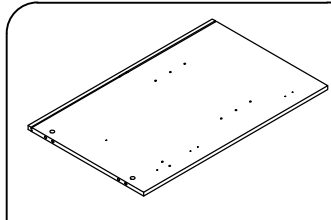

3

1PC

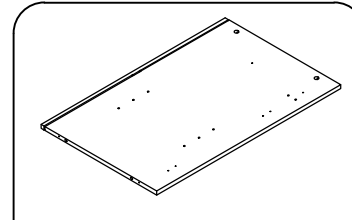

4

1PC

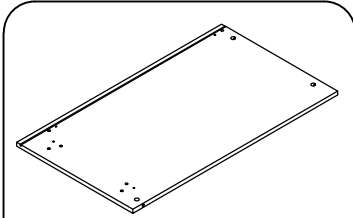

5

1PC

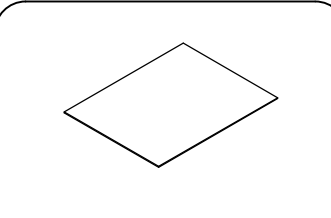

6

2PC

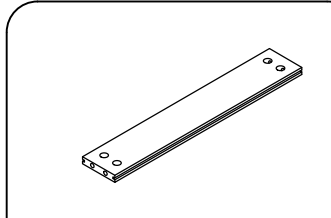

7

1PC

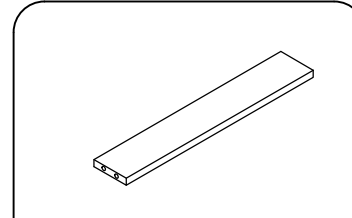

8

1PC

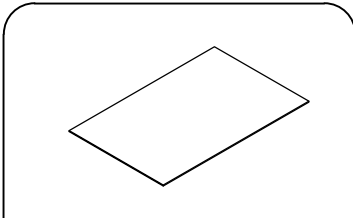

9

2PC

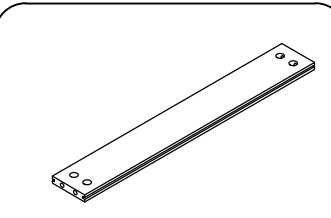

10

1PC

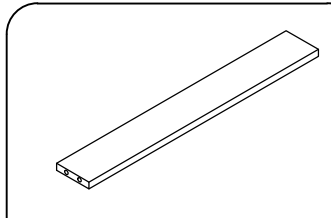

11

1PC

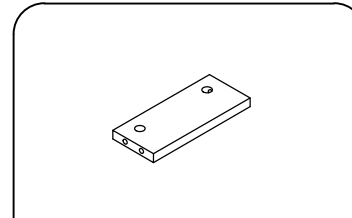

12

2PC

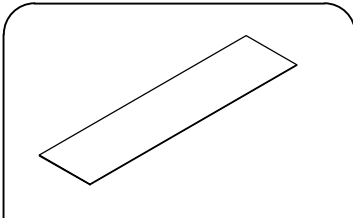

13

1PC

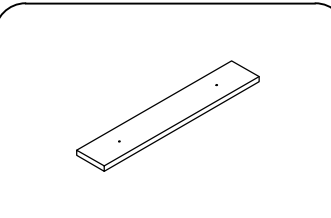

14

2PC

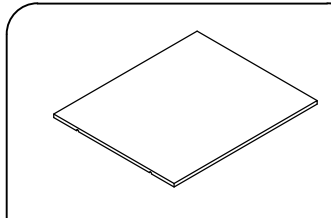

15

1PC

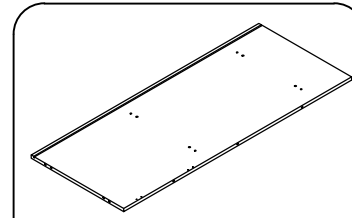

16

1PC

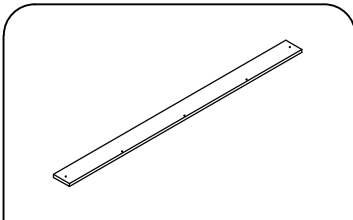

17

1PC

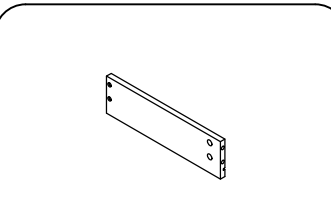

18

2PC

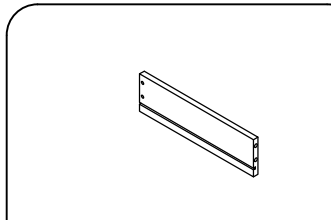

19

2PC

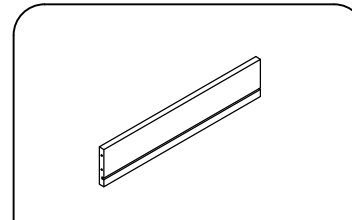

20

1PC

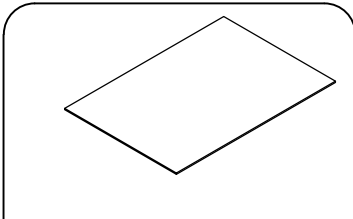

21

1PC

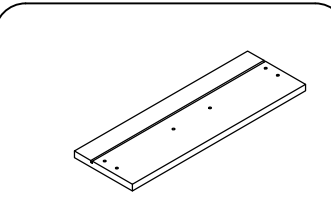

22

1PC

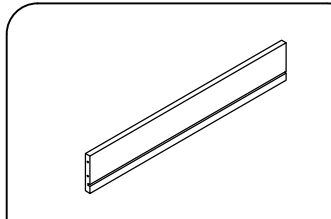

23

1PC

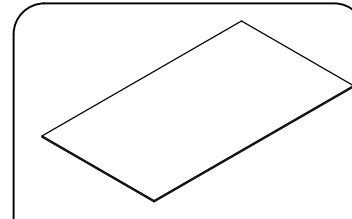

24

1PC

Parts List

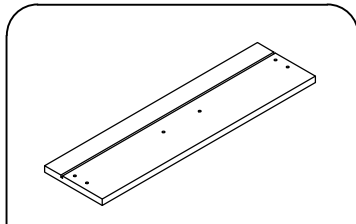

25 1PC

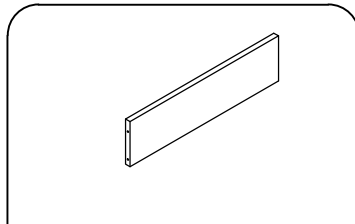

26 1PC

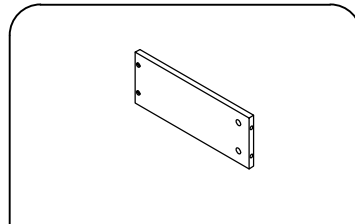

27 1PC

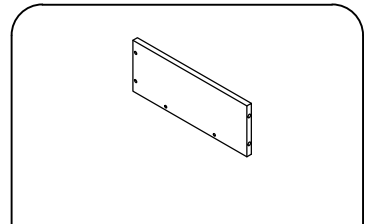

28 1PC

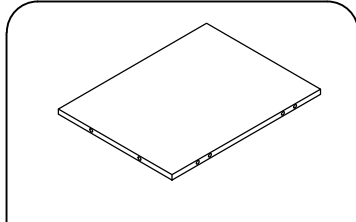

29 1PC

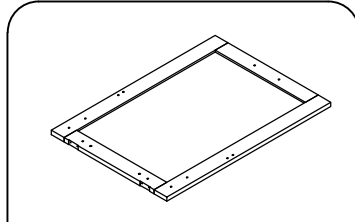

30 1PC

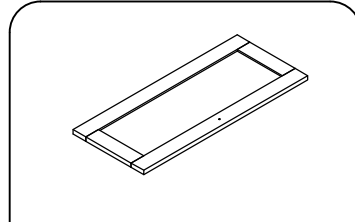

31 2PC

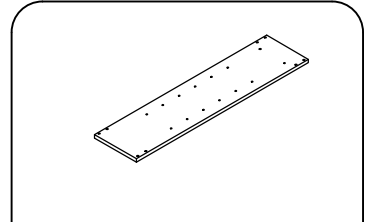

32 1PC

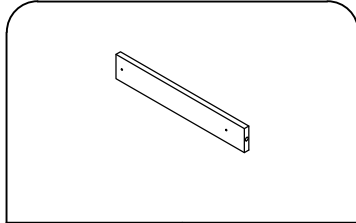

33 2PC

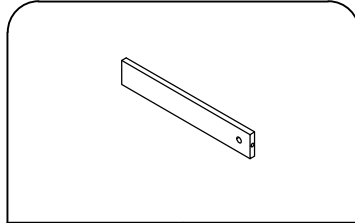

34 2PC

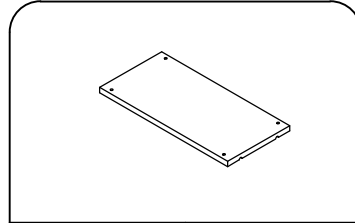

35 2PC

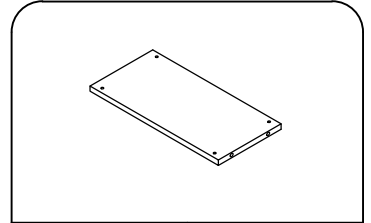

36 1PC

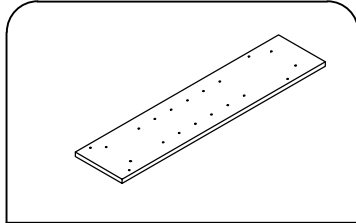

37 1PC

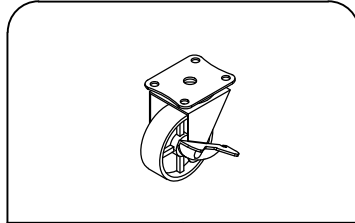

38 2PC

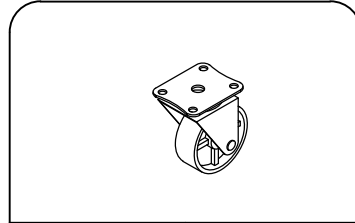

39 3PC

Hardware List



A 61PC

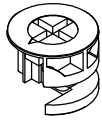

ø15

B 37PC



Ø8*30mm

C 20PC

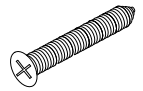

Ø4*40mm

D 26PC

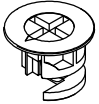

ø12

E 24PC

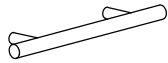

F 4PC



ø3*12mm

G 40PC



Ø4*14MM

H 20PC

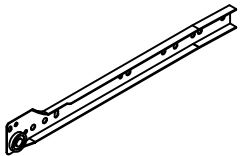

I 2PC

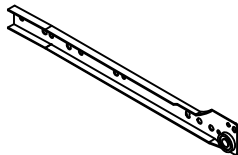

J 2PC

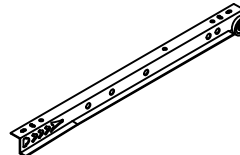

K 2PC

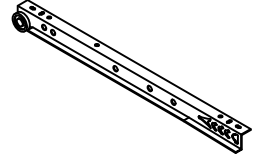

L 2PC



M4*18mm

M 10PC

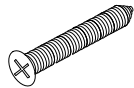

Ø4*25mm

N 4PC

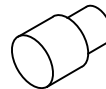

O 12PC



P 2PC



ø3.5*14mm

Q 16PC

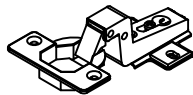

R 4PC



Ø6*30mm

S 2PC

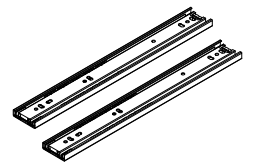

T 1PC



U 2PC

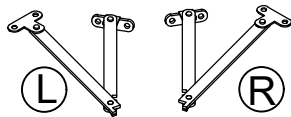

V 1PC

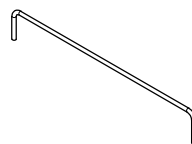

W 6PC

STEP 1

Slides Must Be Separated Before Assembly.
After Separated ,Set Aside Until Needed for
Assembly.

STEP 1: Extend Slide

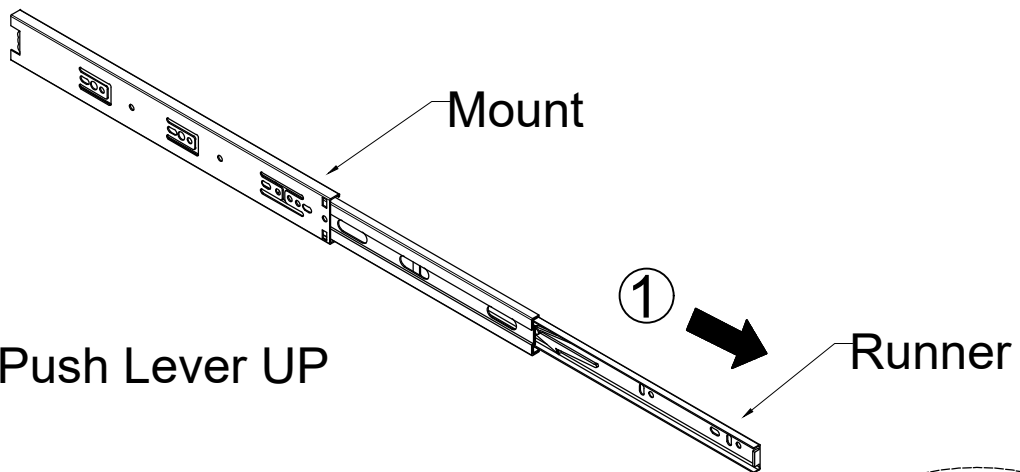

STEP 2: Push Lever UP

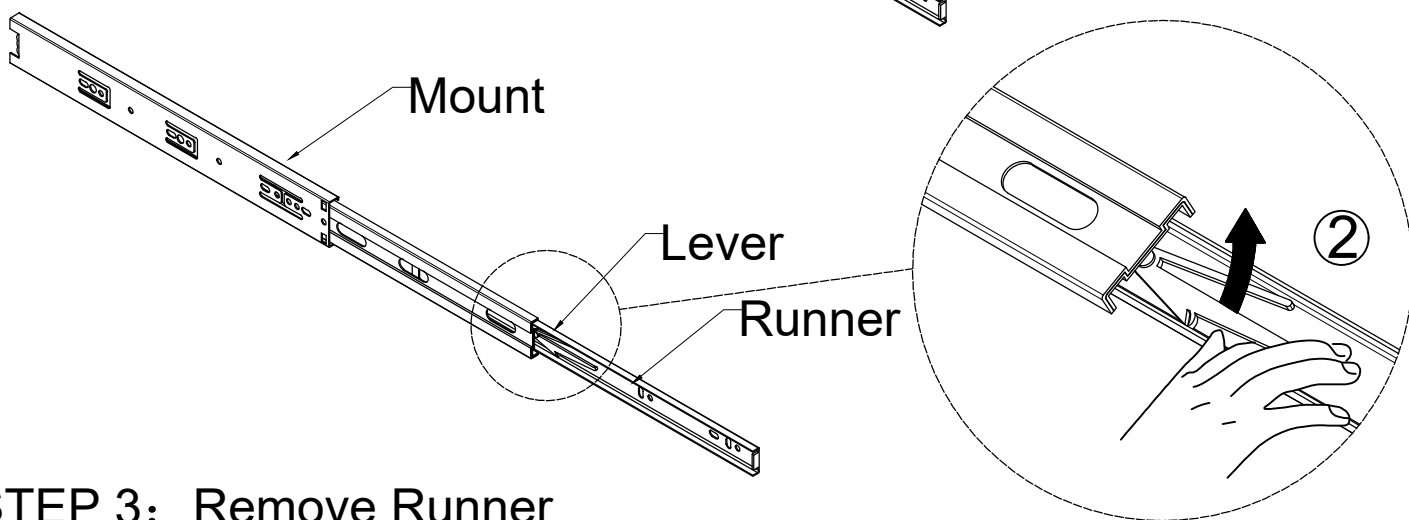

STEP 3: Remove Runner

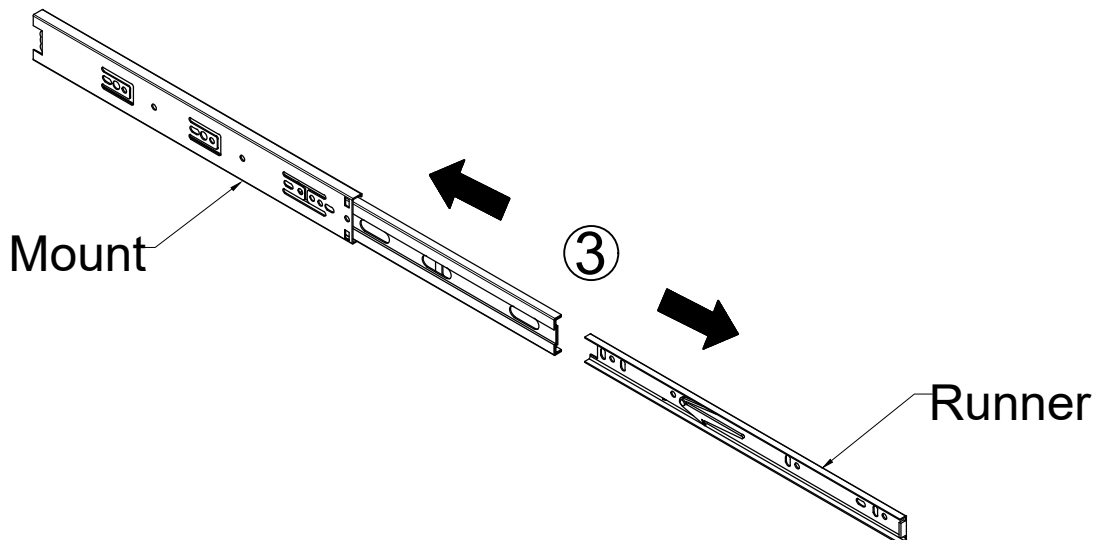

STEP 2

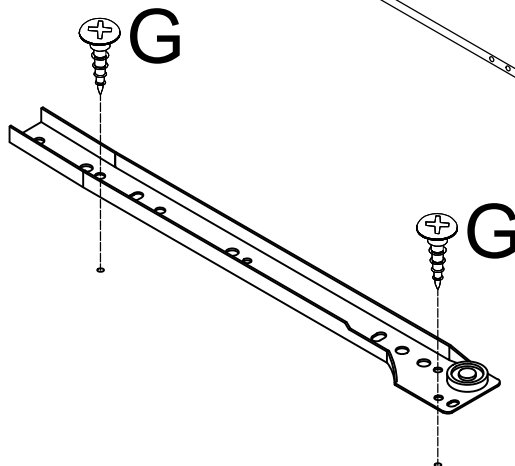
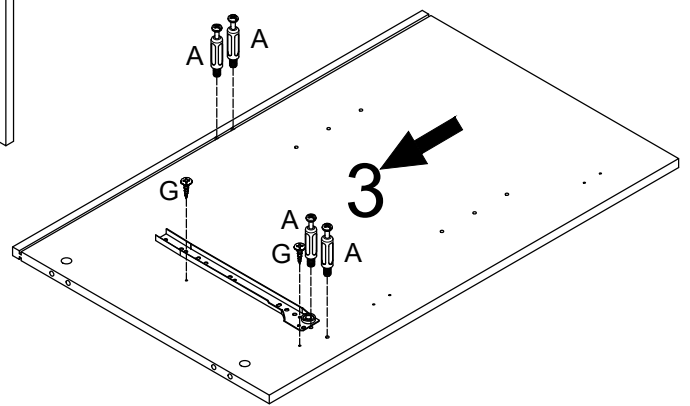
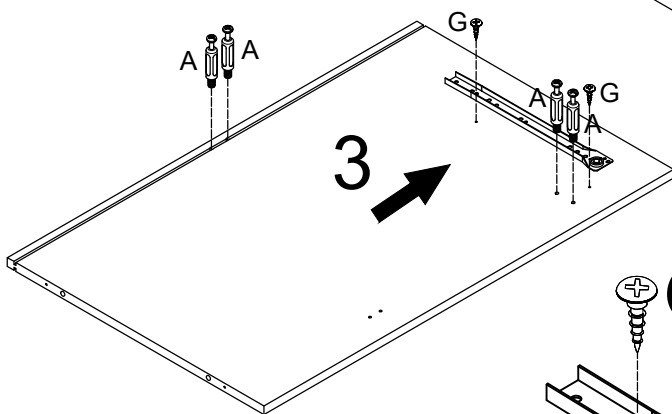
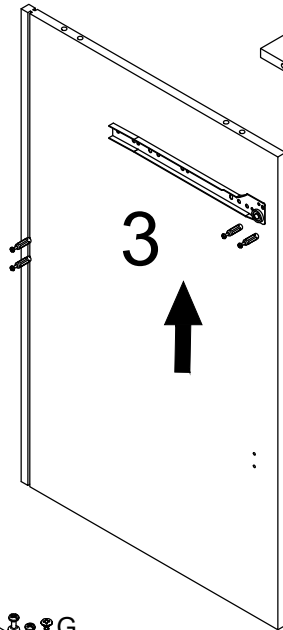
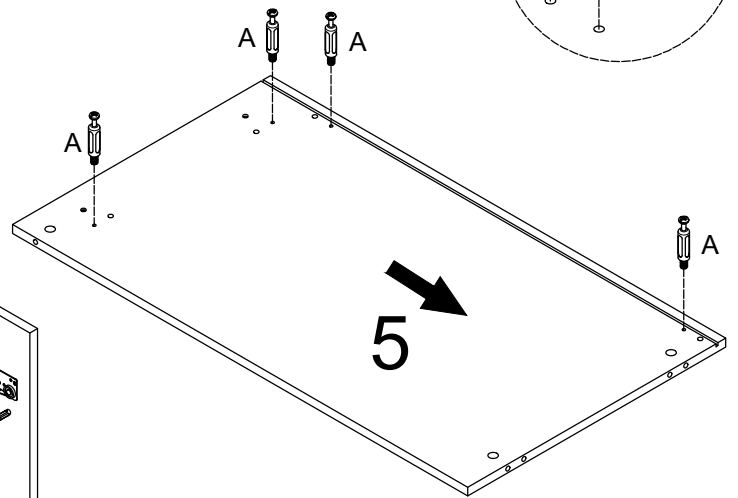
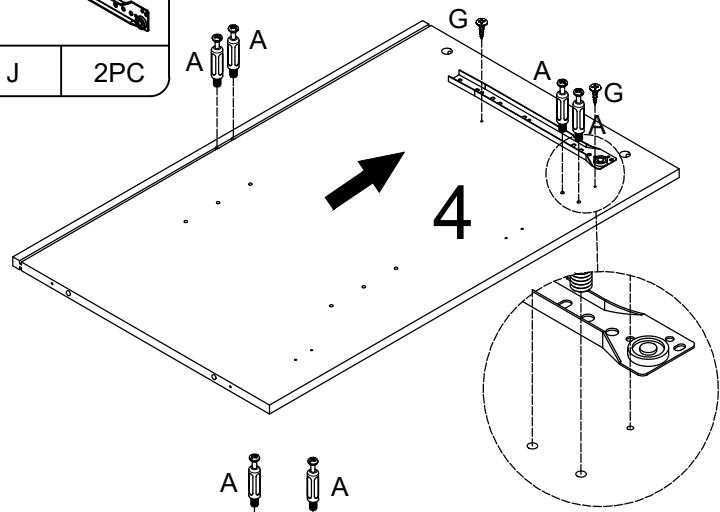
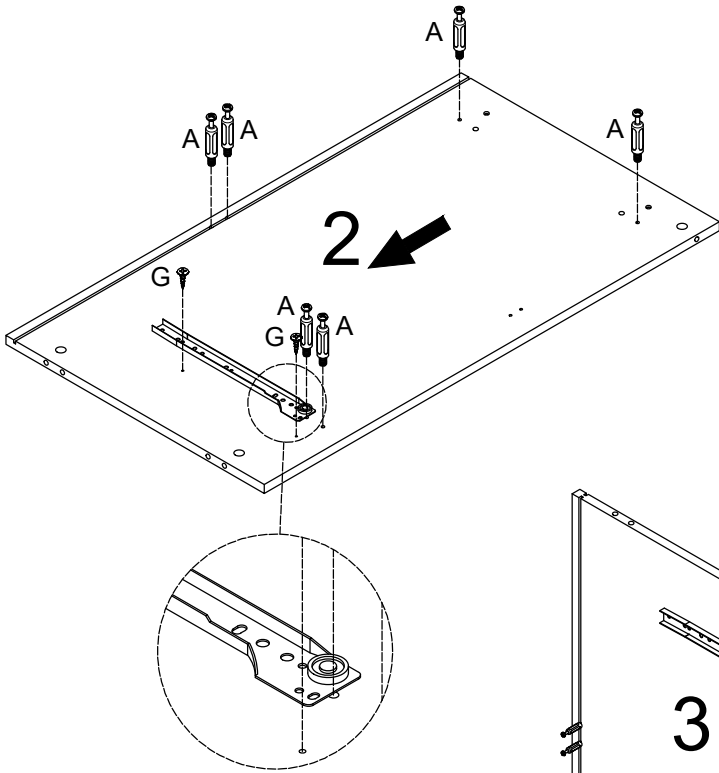
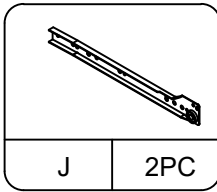
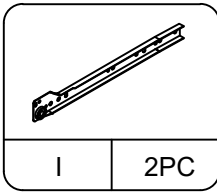
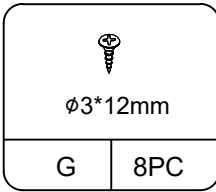
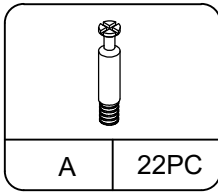

STEP 3

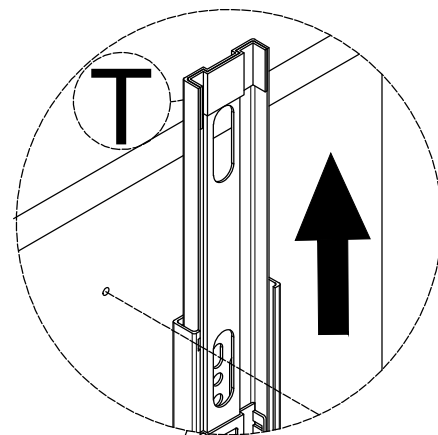
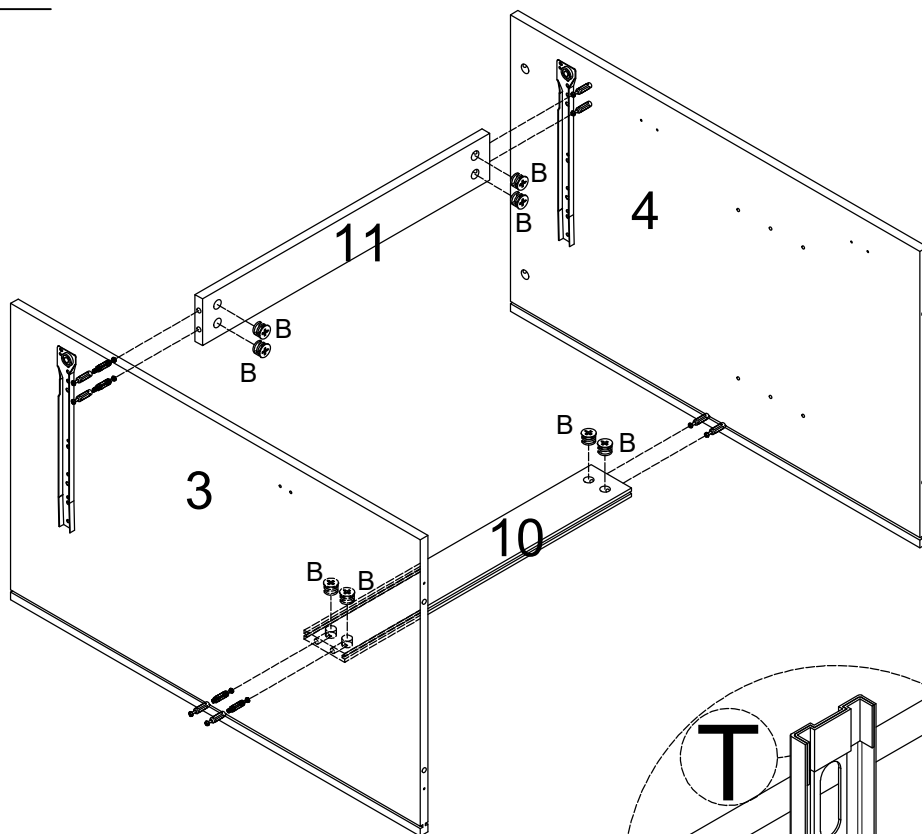
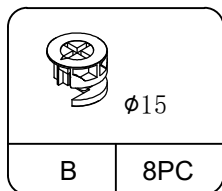

STEP 4

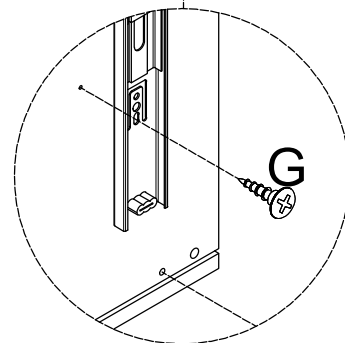
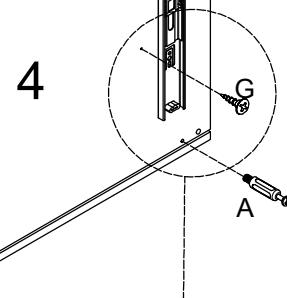
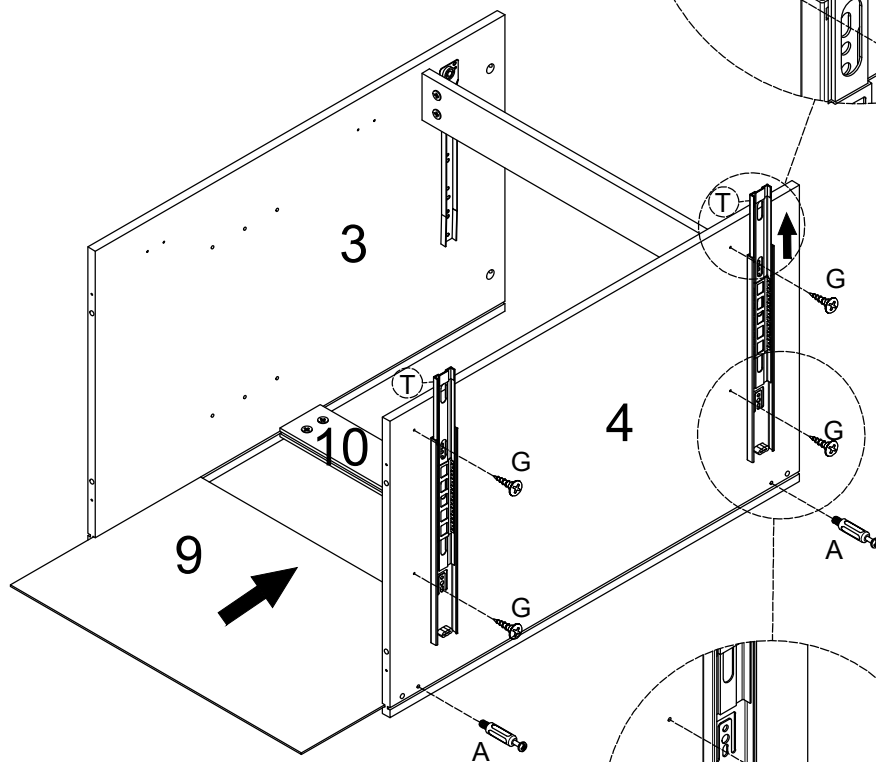
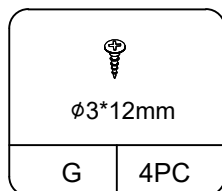
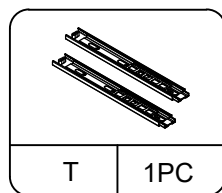
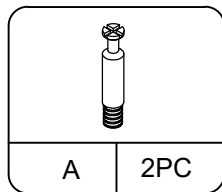

STEP 5

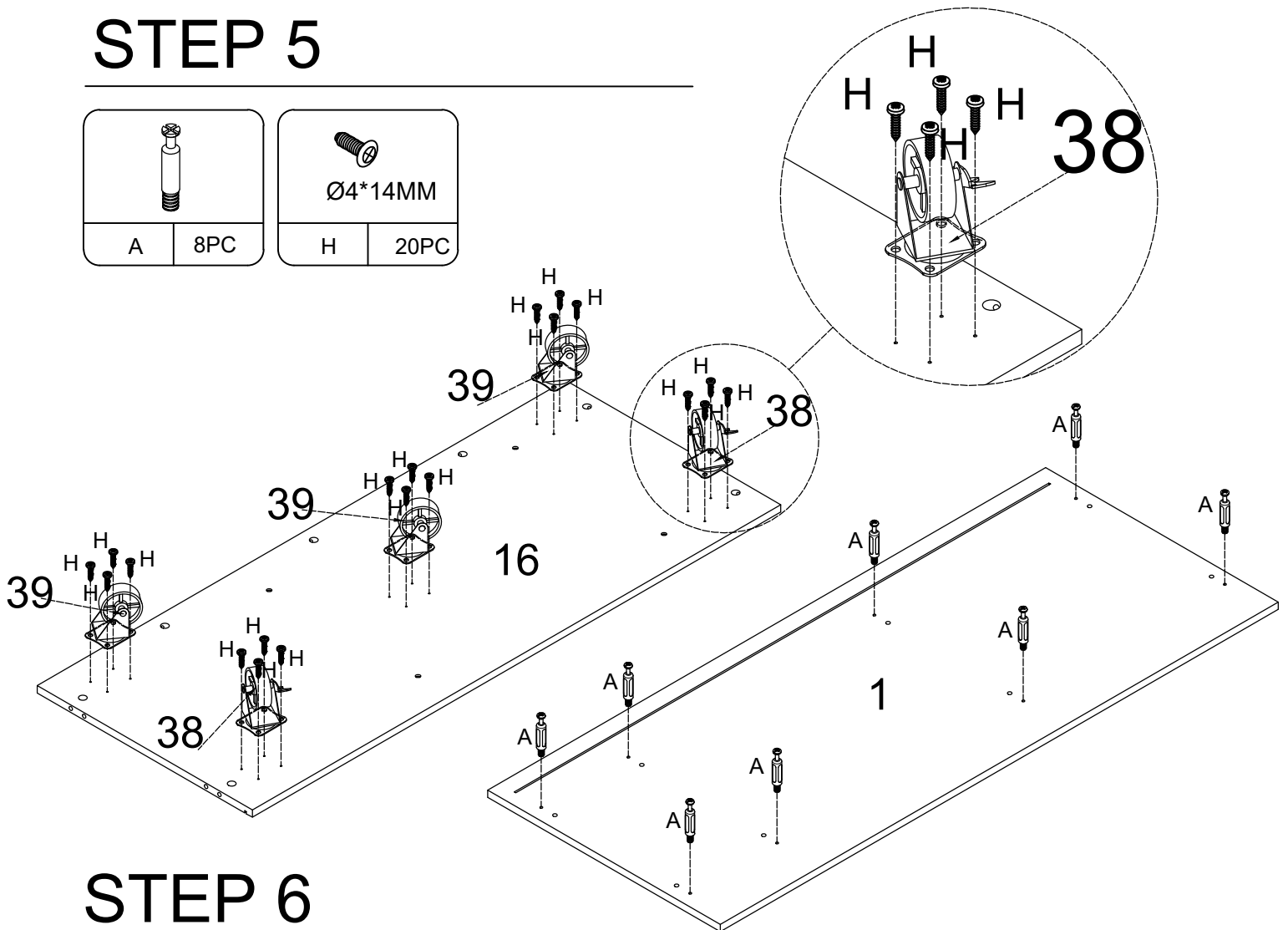
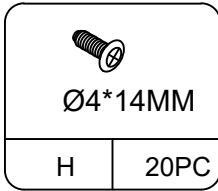
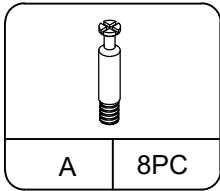

STEP 6

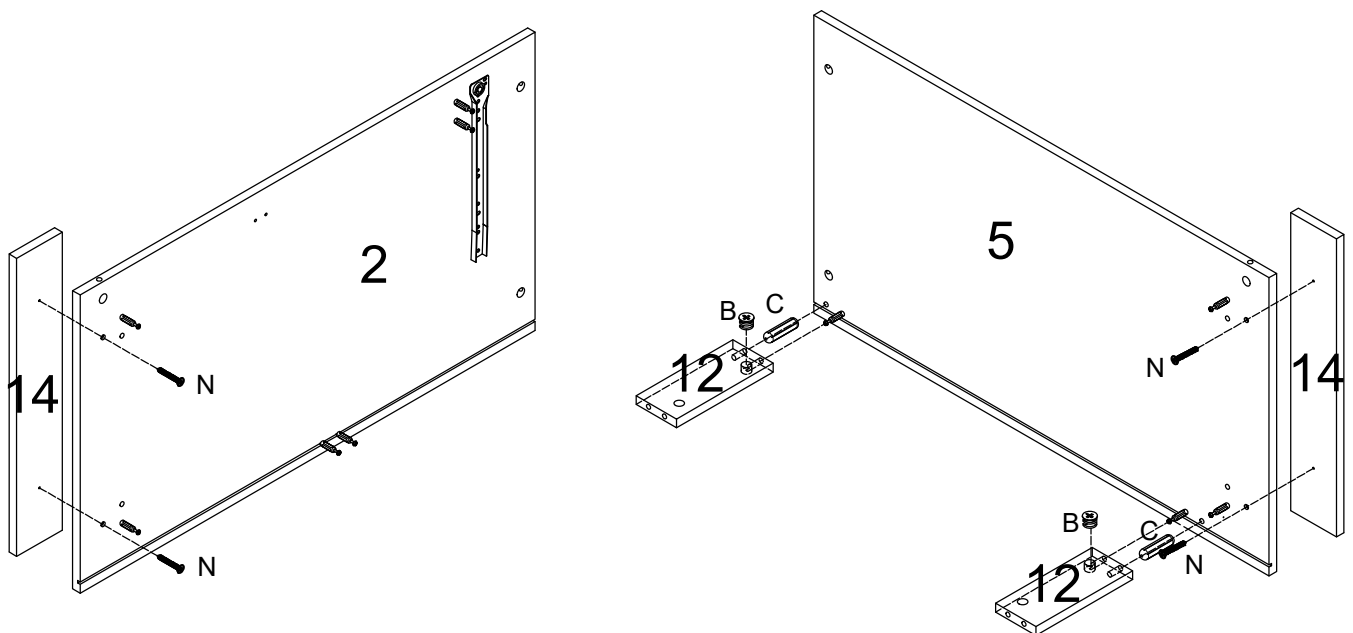
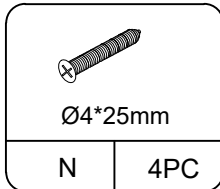
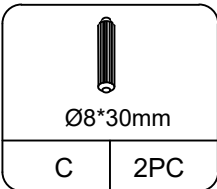
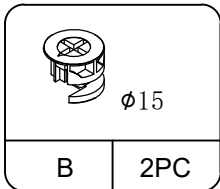

STEP 7

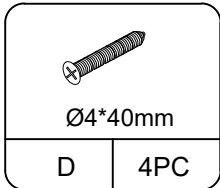
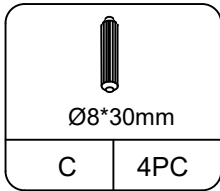
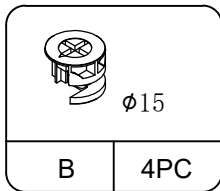

Important
2 people required
2 personnes requises
2 personas requeridas

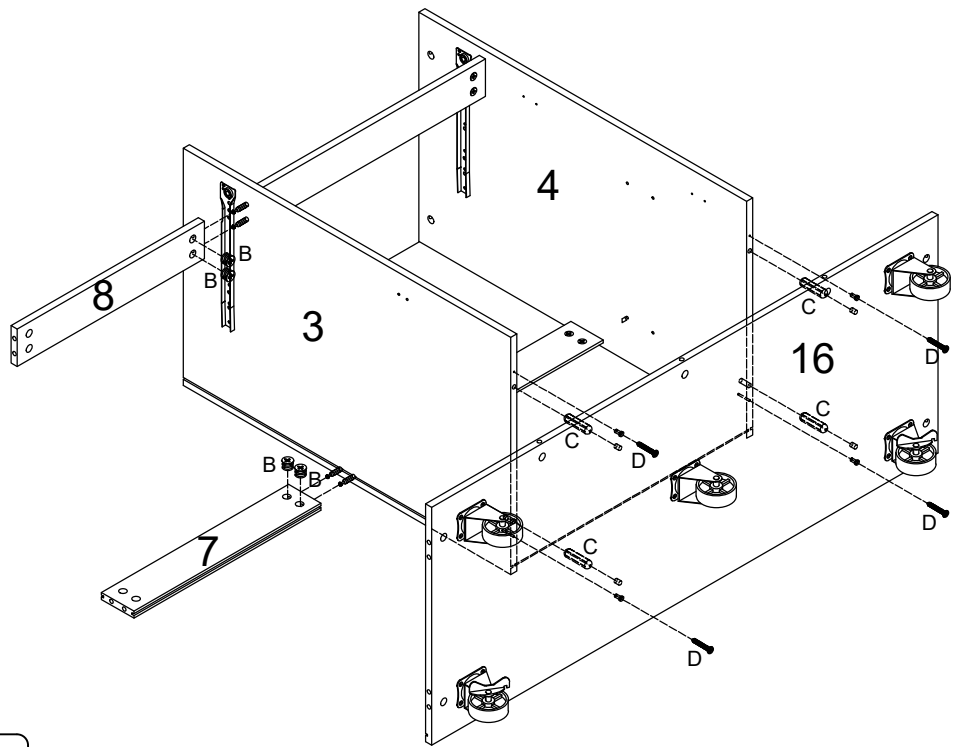

STEP 8

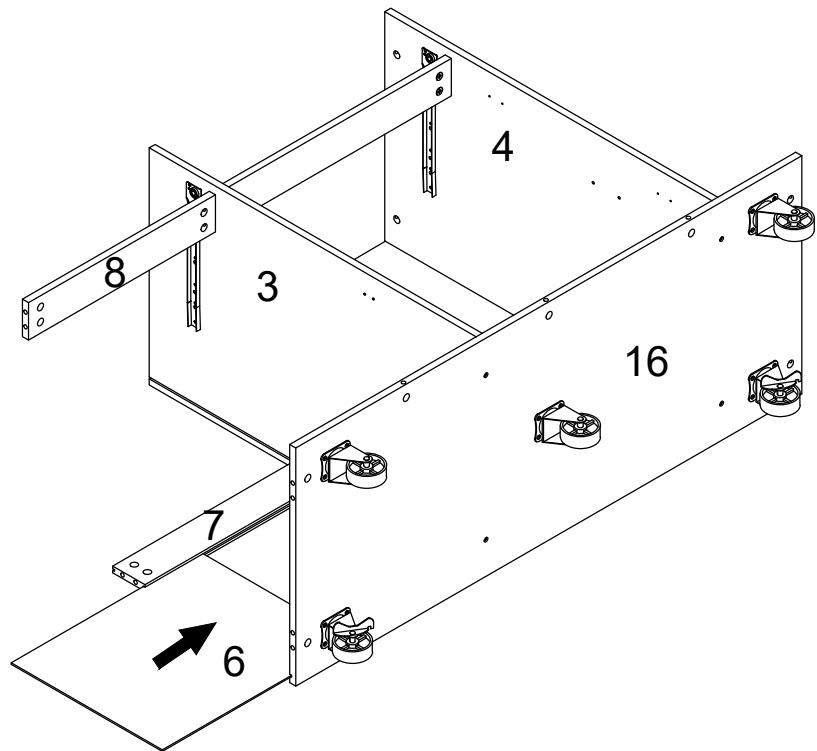

STEP 9



Ø15

| | |
|---|------|
| B | 10PC |
|---|------|



Ø8*30mm

| | |
|---|-----|
| C | 6PC |
|---|-----|



Important
 2 people required
 2 personnes requises
 2 personas requeridas

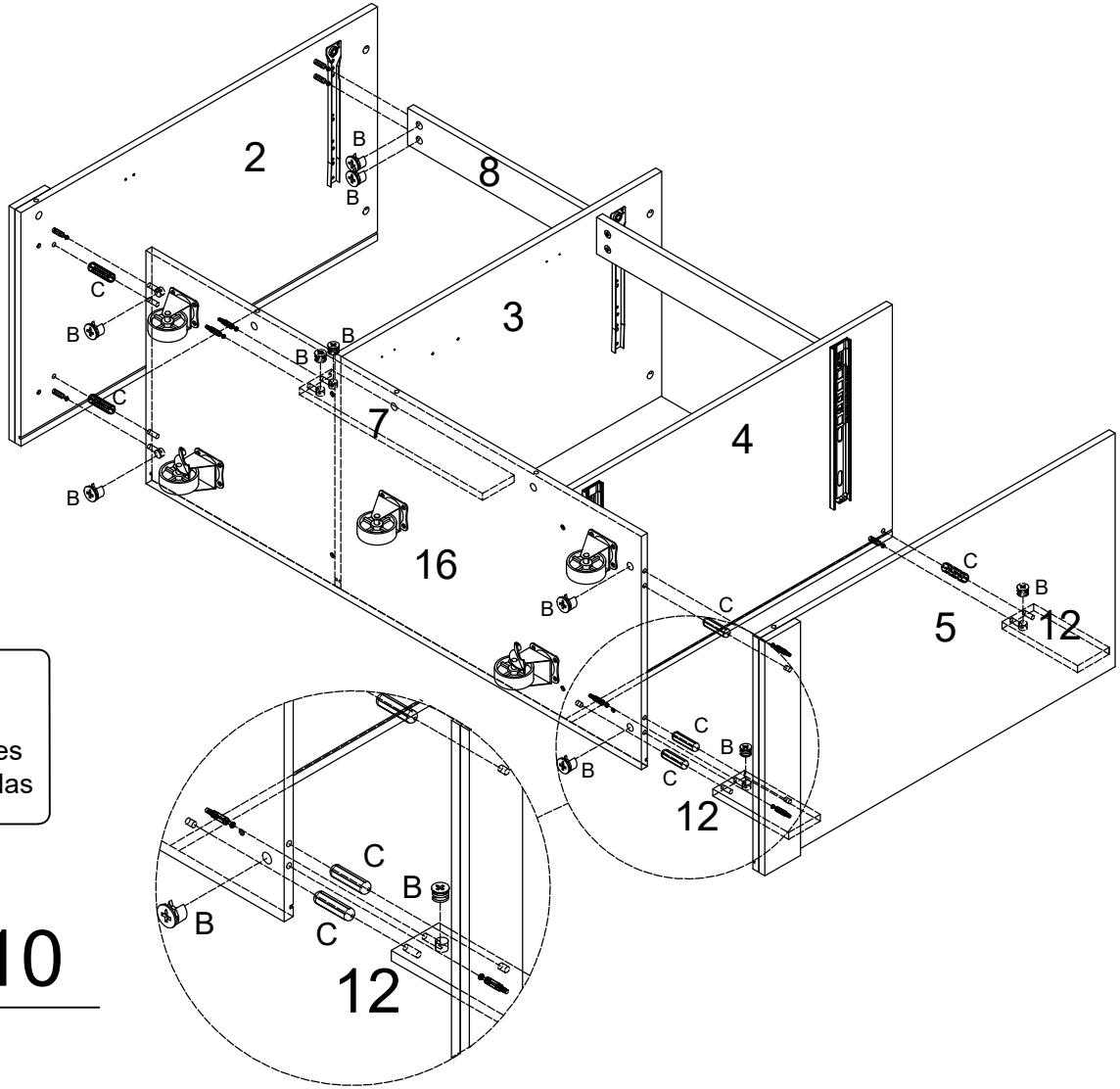

STEP 10



A

| | |
|---|-----|
| A | 5PC |
|---|-----|



Ø15

| | |
|---|-----|
| B | 5PC |
|---|-----|

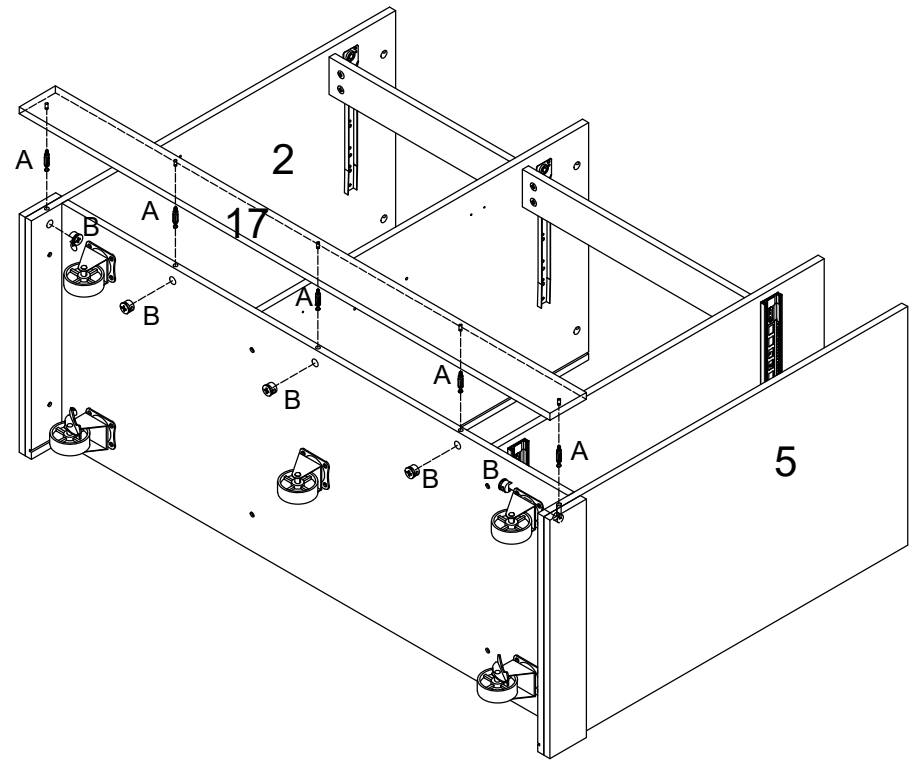

STEP 11

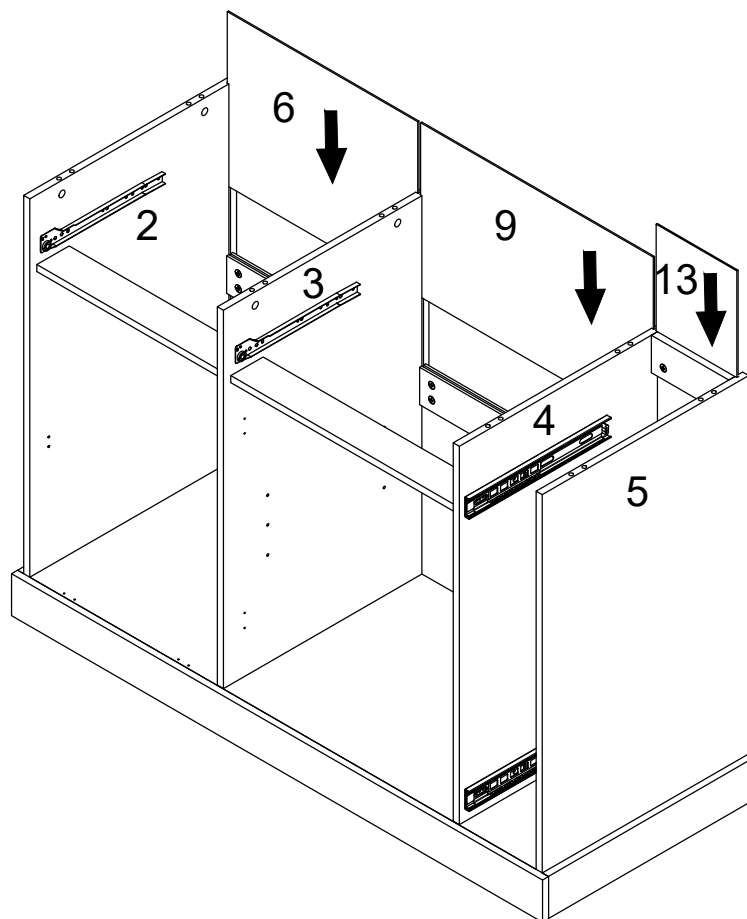

STEP 12

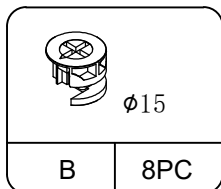

B 8PC

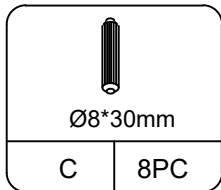

C 8PC

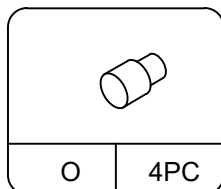

O 4PC

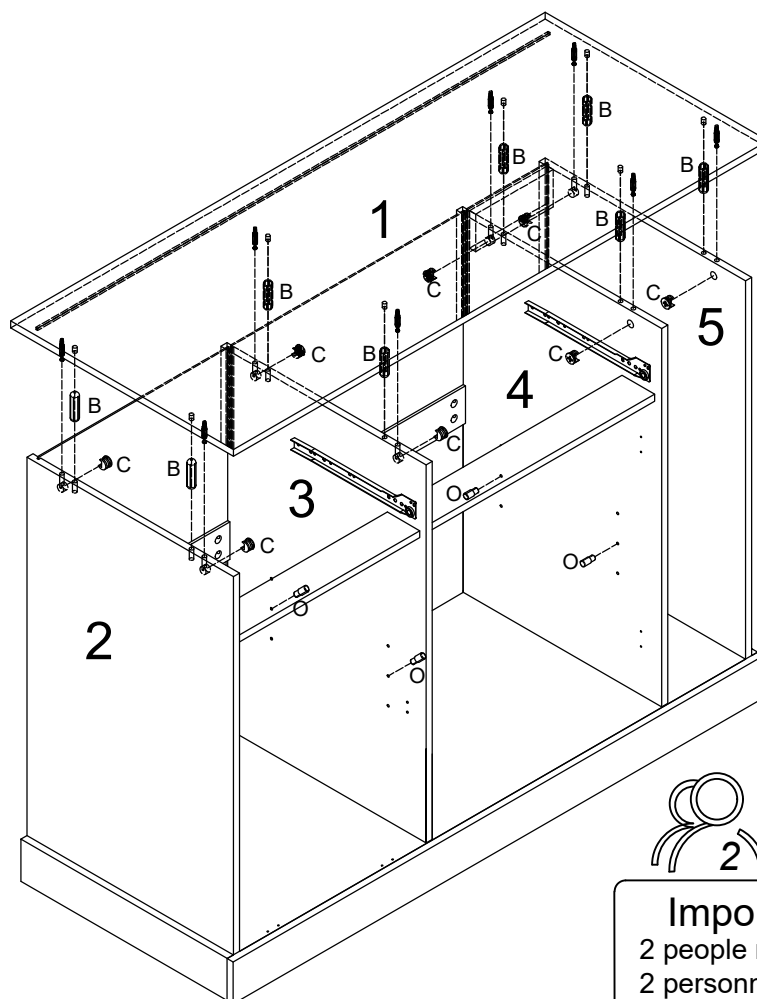

Important
 2 people required
 2 personnes requises
 2 personas requeridas

STEP 13

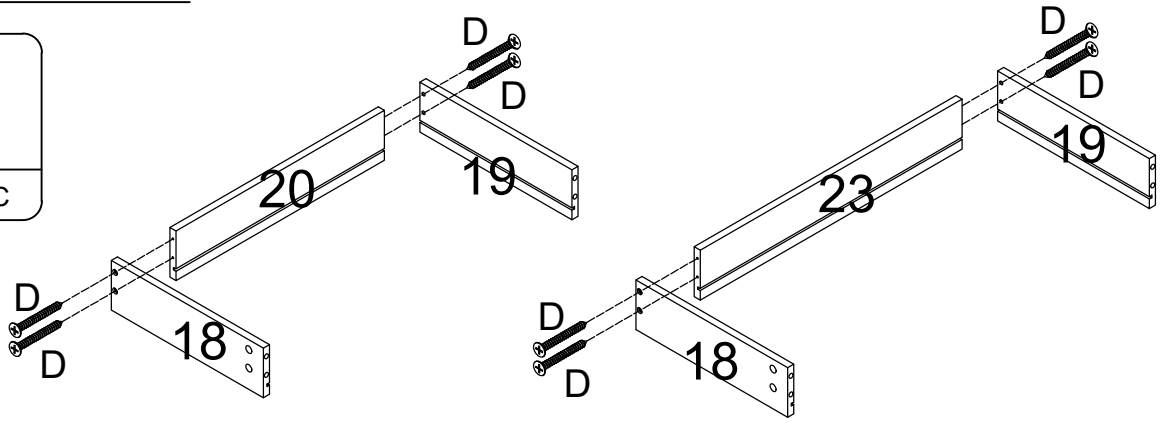
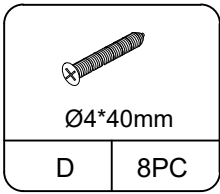

STEP 14

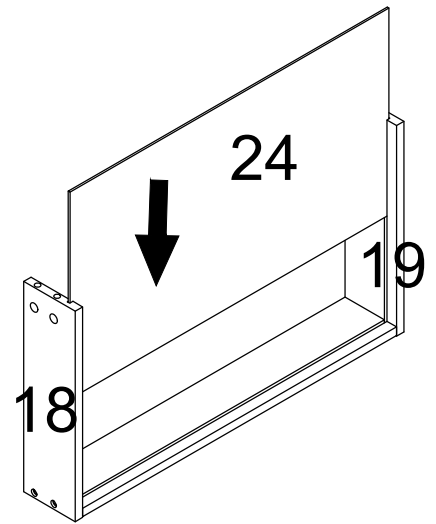
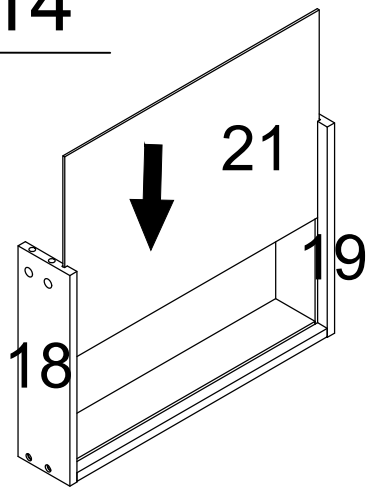

STEP 15

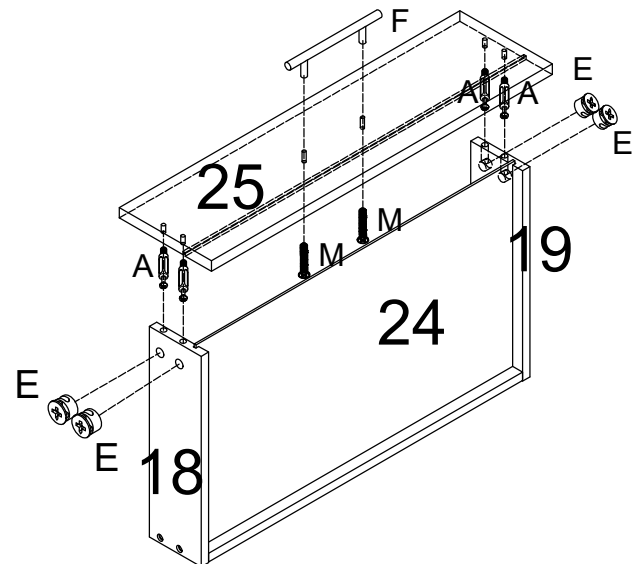
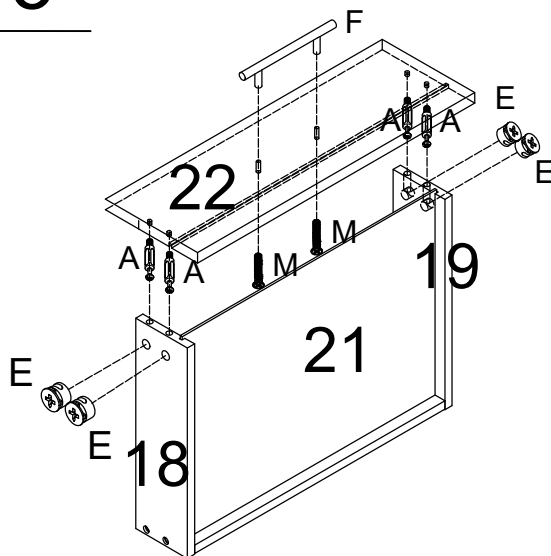
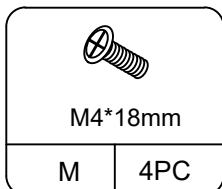
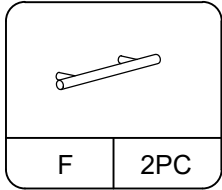
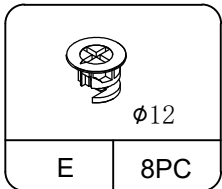
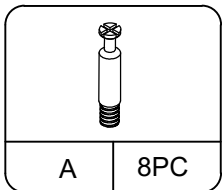

STEP 16

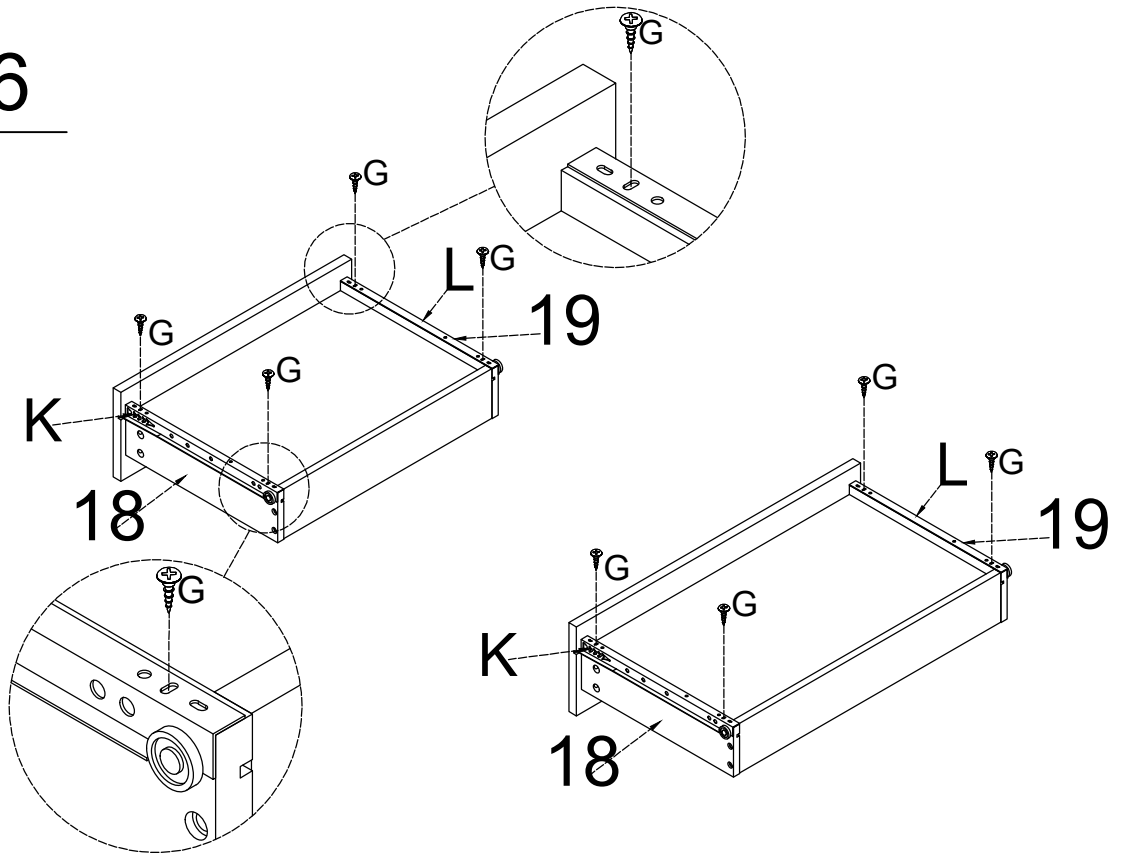
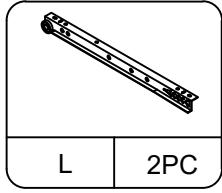
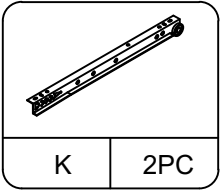
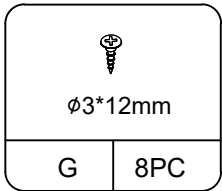

STEP 17

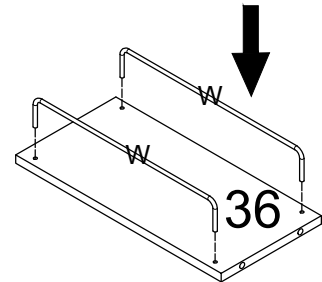
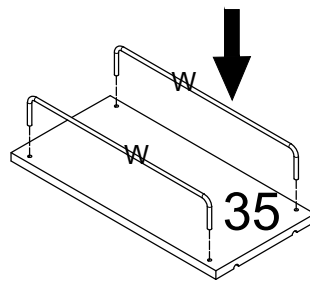
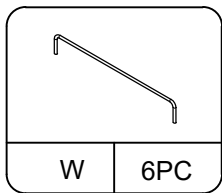

x2PCS

STEP 18

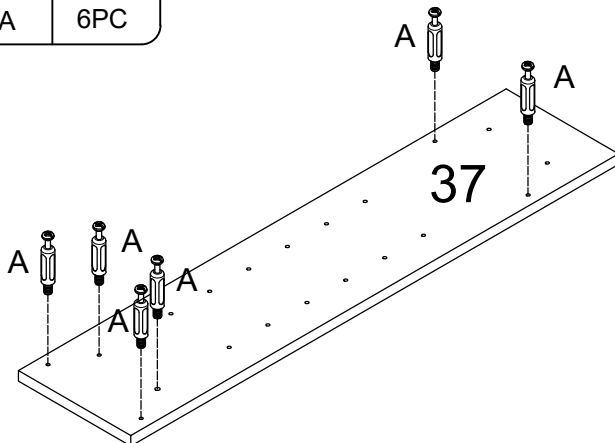
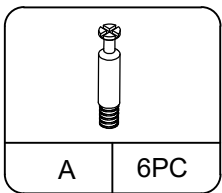

STEP 19

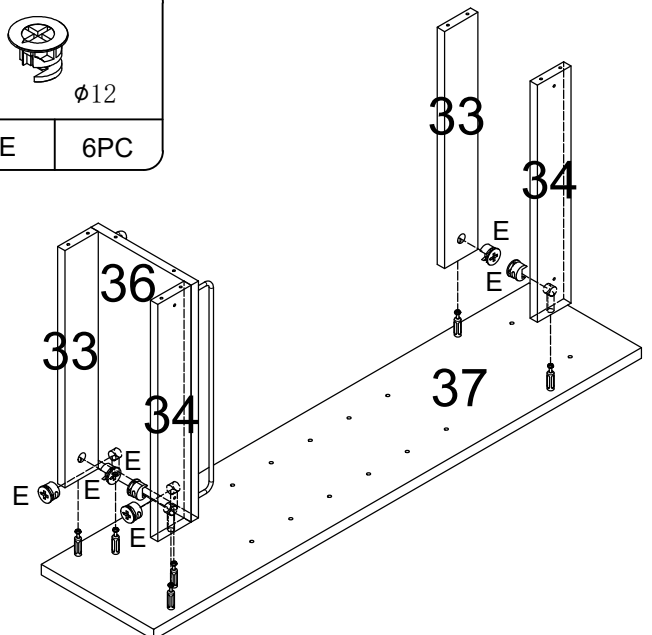
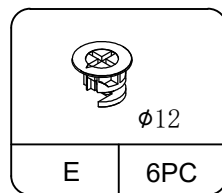

STEP 20

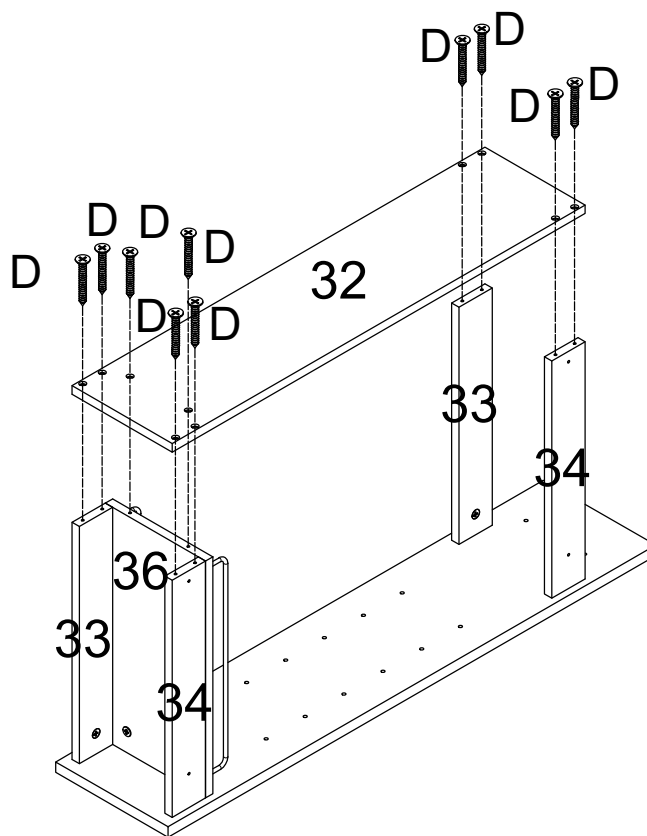
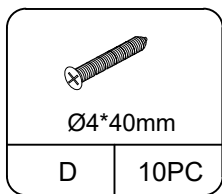

STEP 21

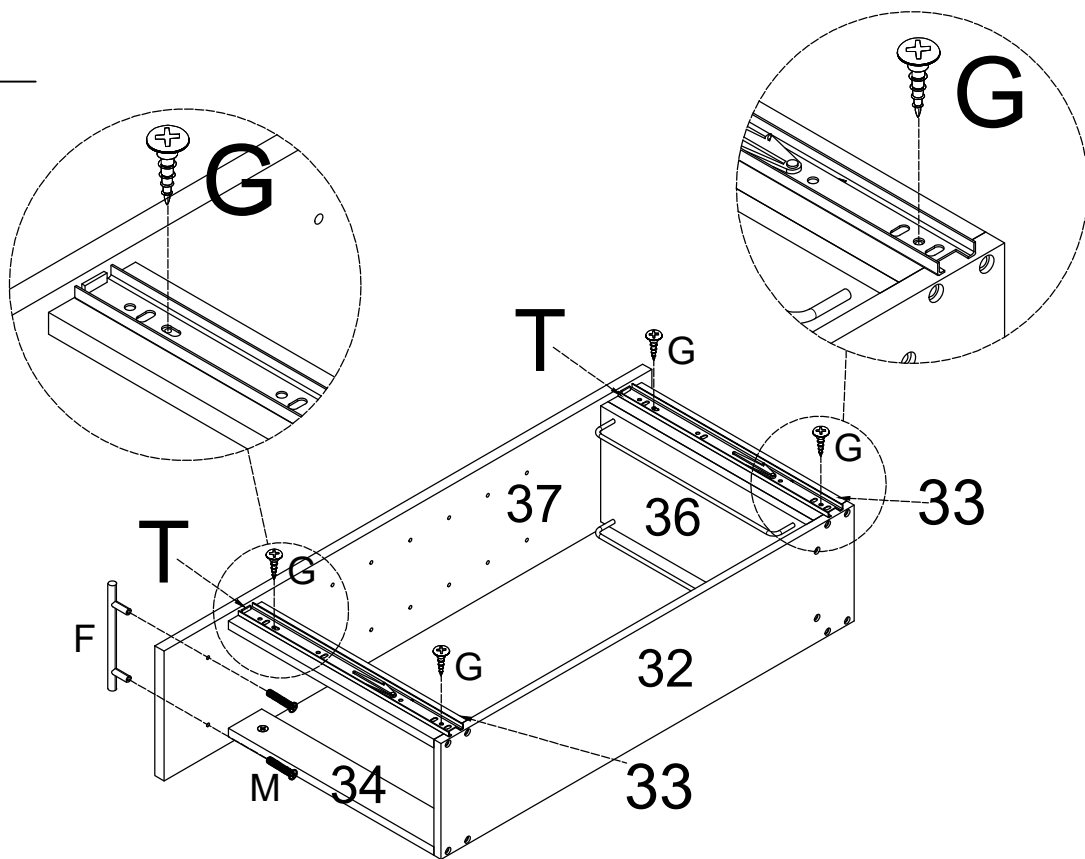
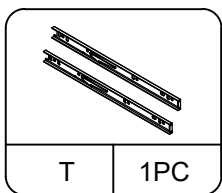
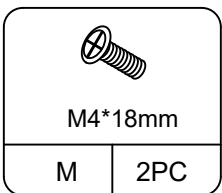
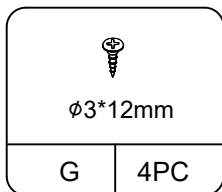
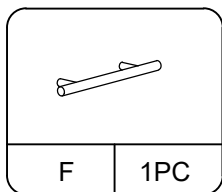

STEP 22

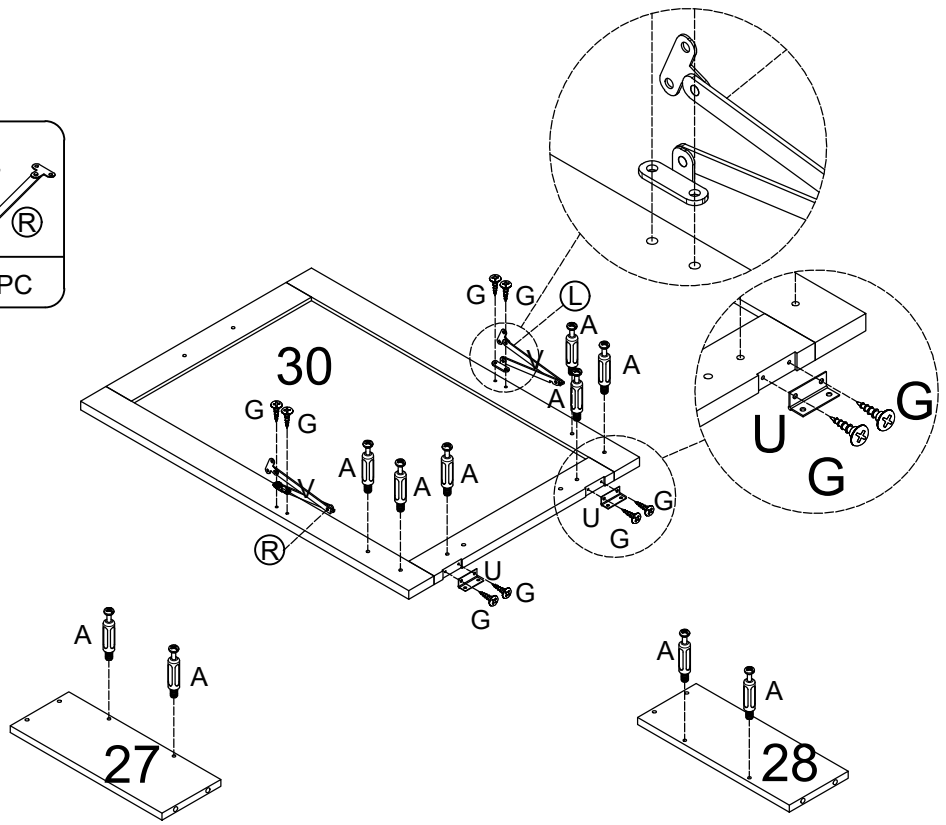
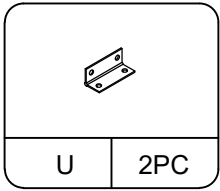
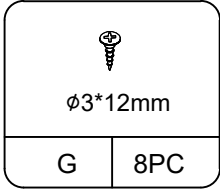
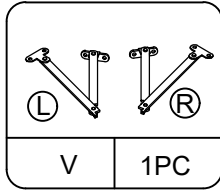
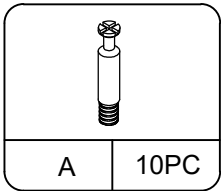

STEP 23

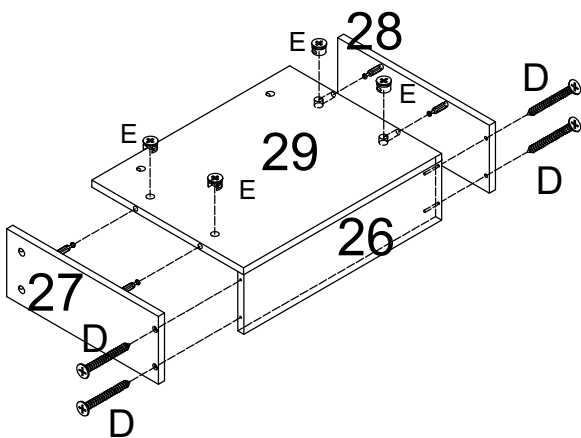
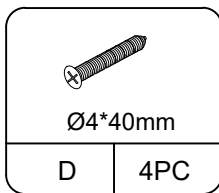
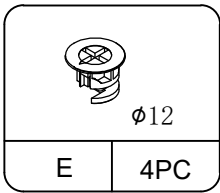

STEP 24

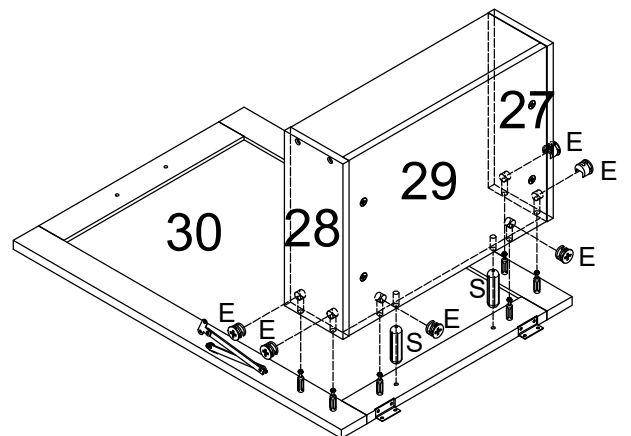
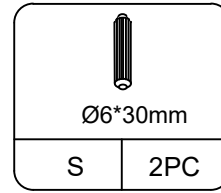
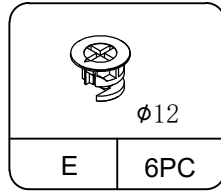

STEP 25

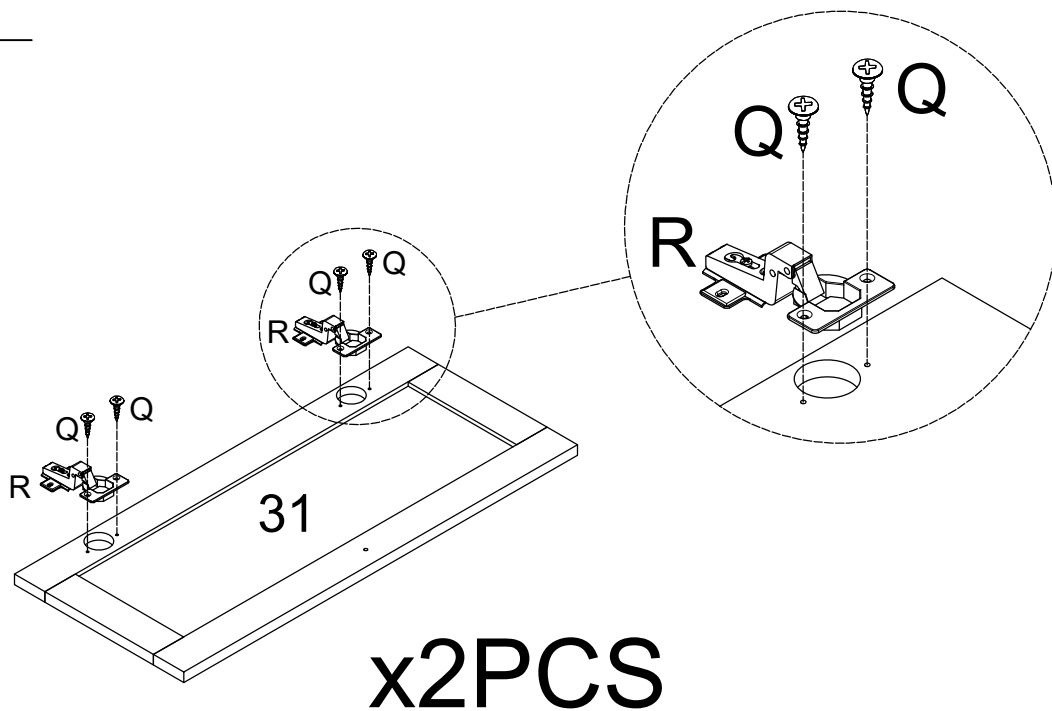
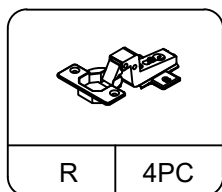
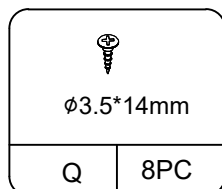

STEP 26

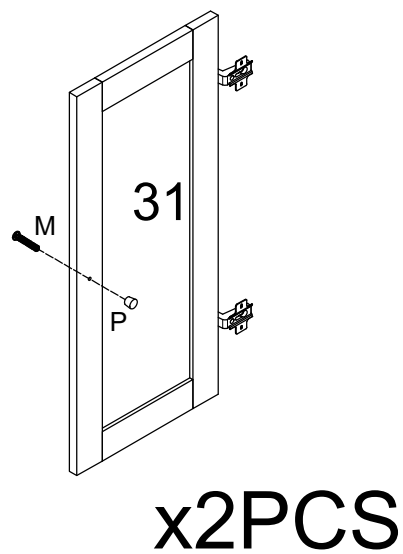
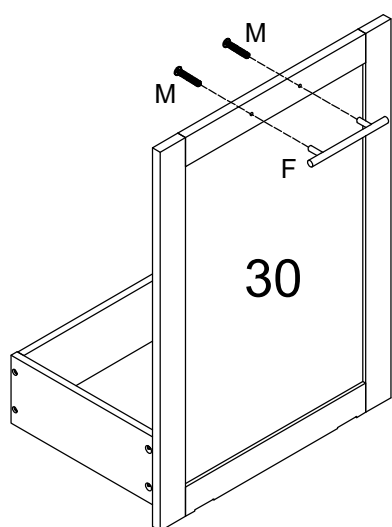
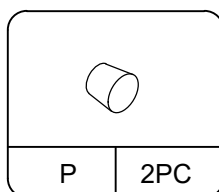
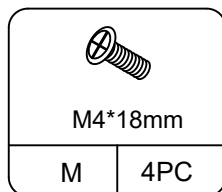
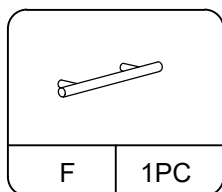

STEP 27

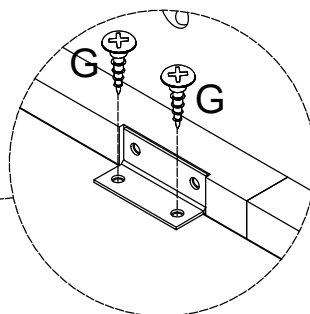
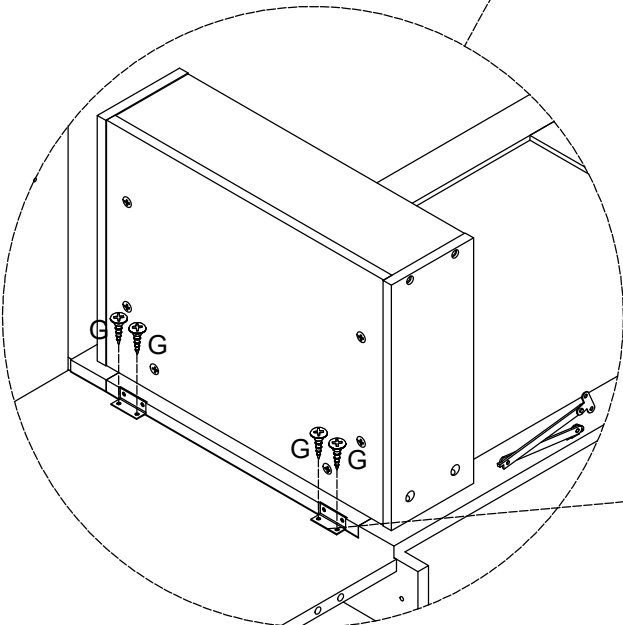
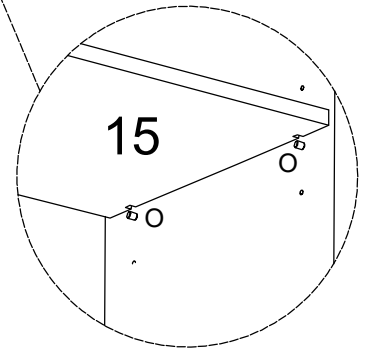
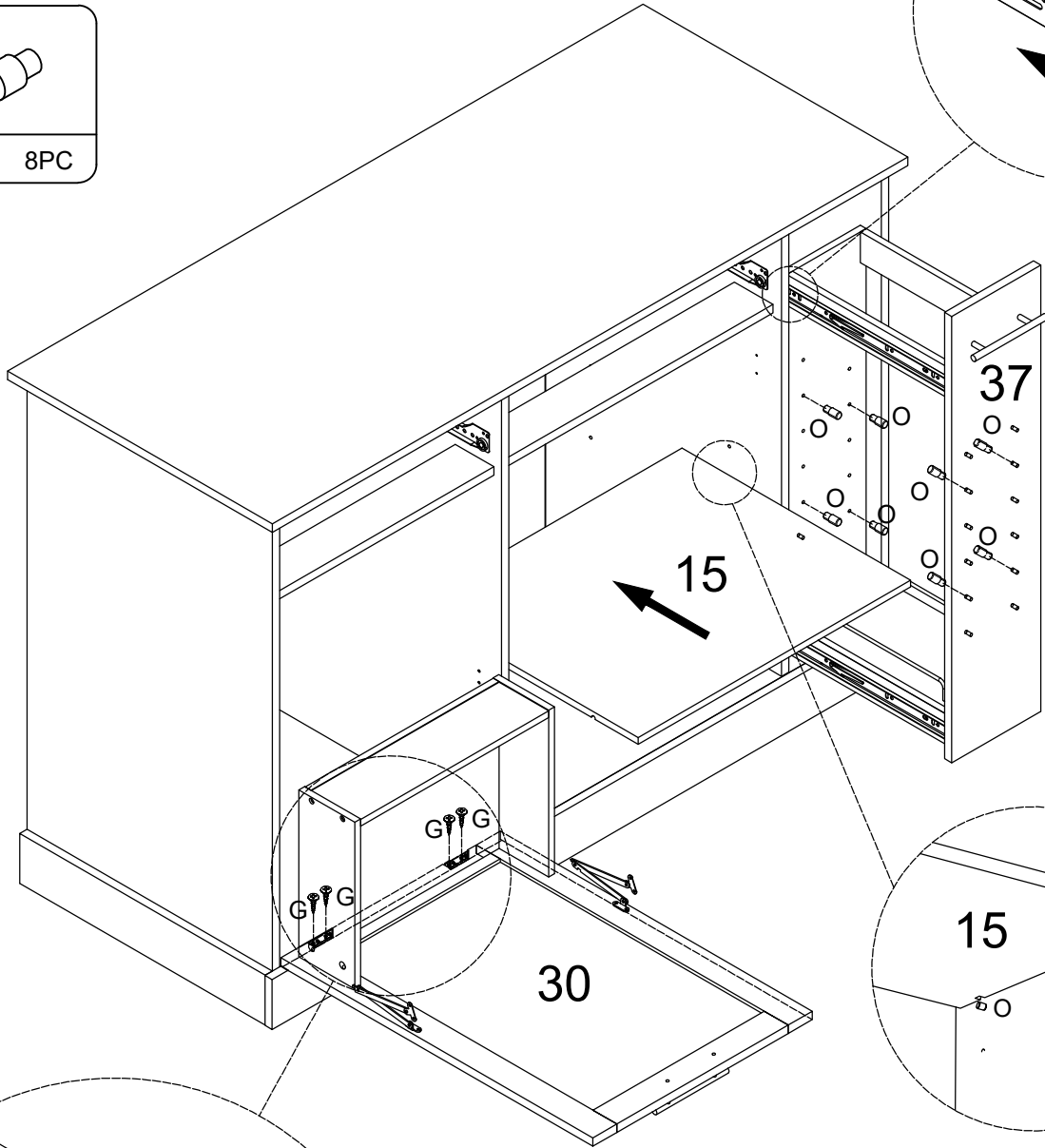
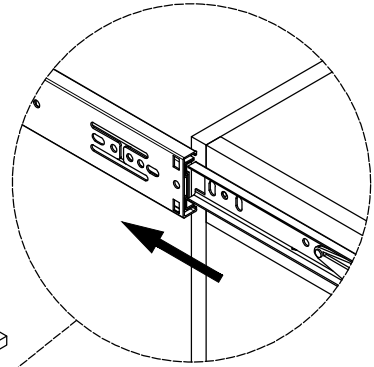
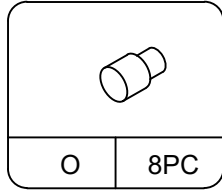
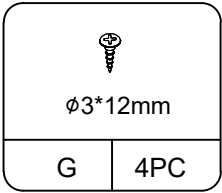

Important
2 people required
2 personnes requises
2 personas requeridas

STEP 28

| | |
|--|-----|
|  ø3*12mm | |
| G | 4PC |

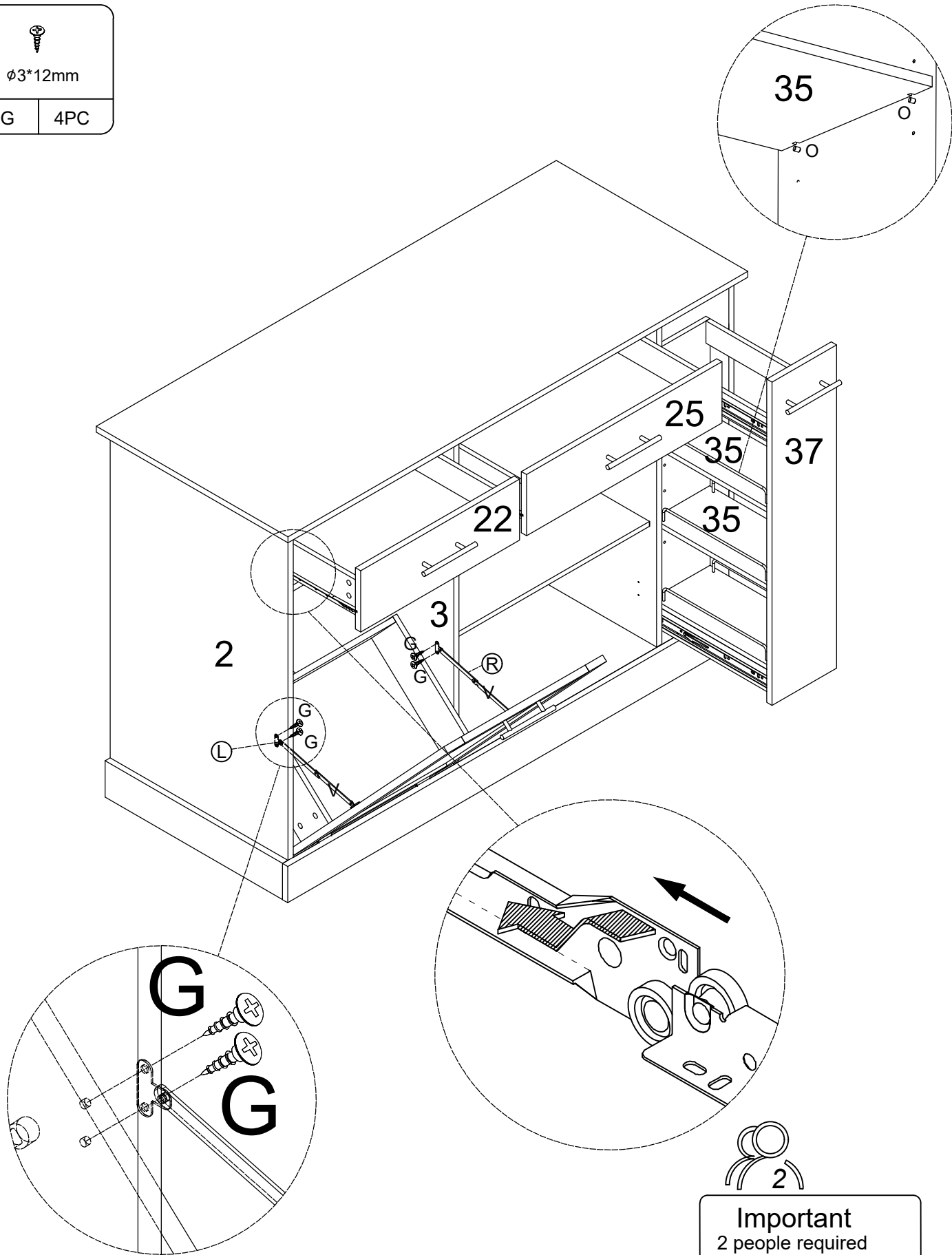

Important
2 people required
2 personnes requises
2 personas requeridas

STEP 29



Ø3.5*14mm

Q

8PC

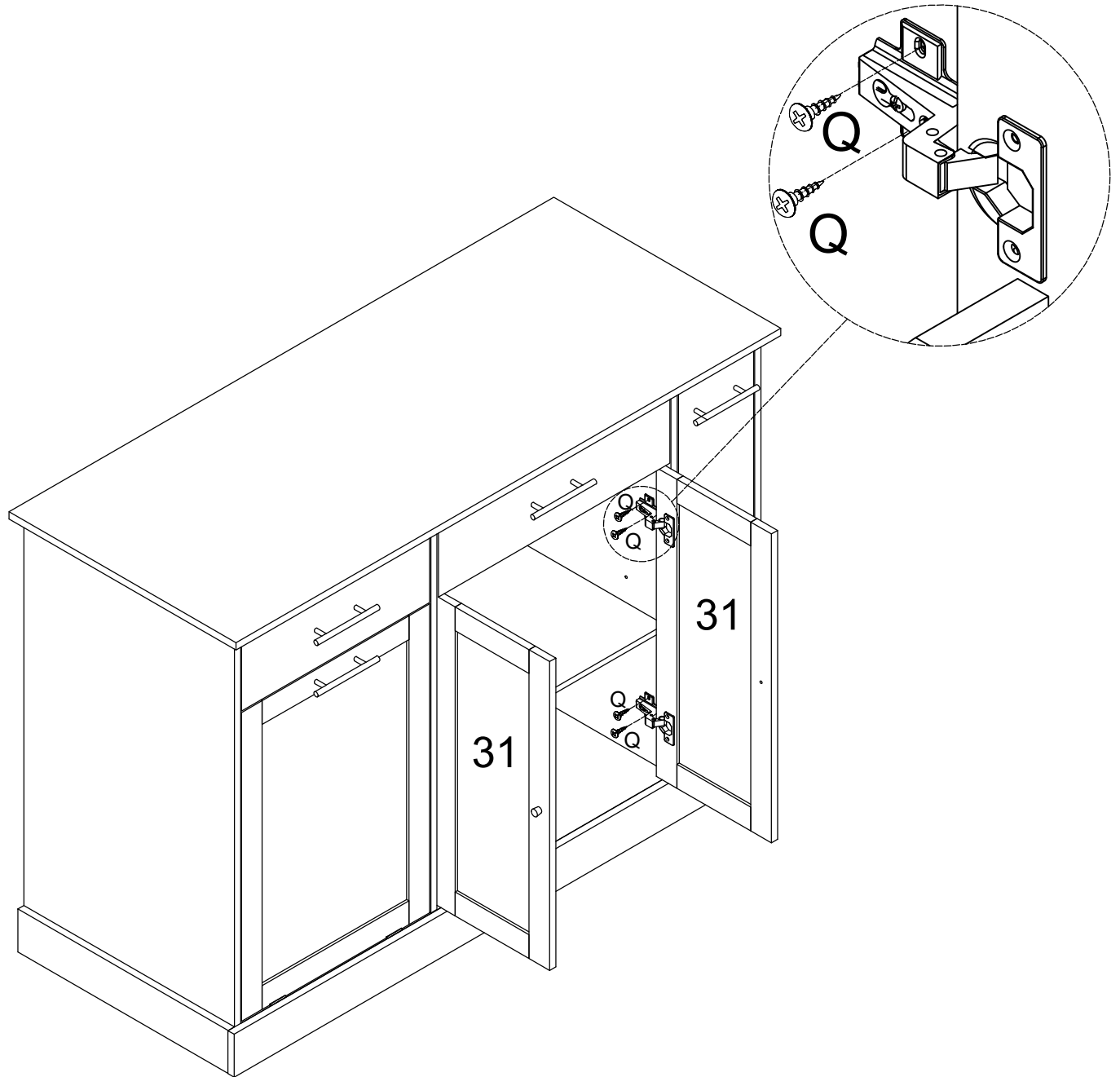

STEP 30

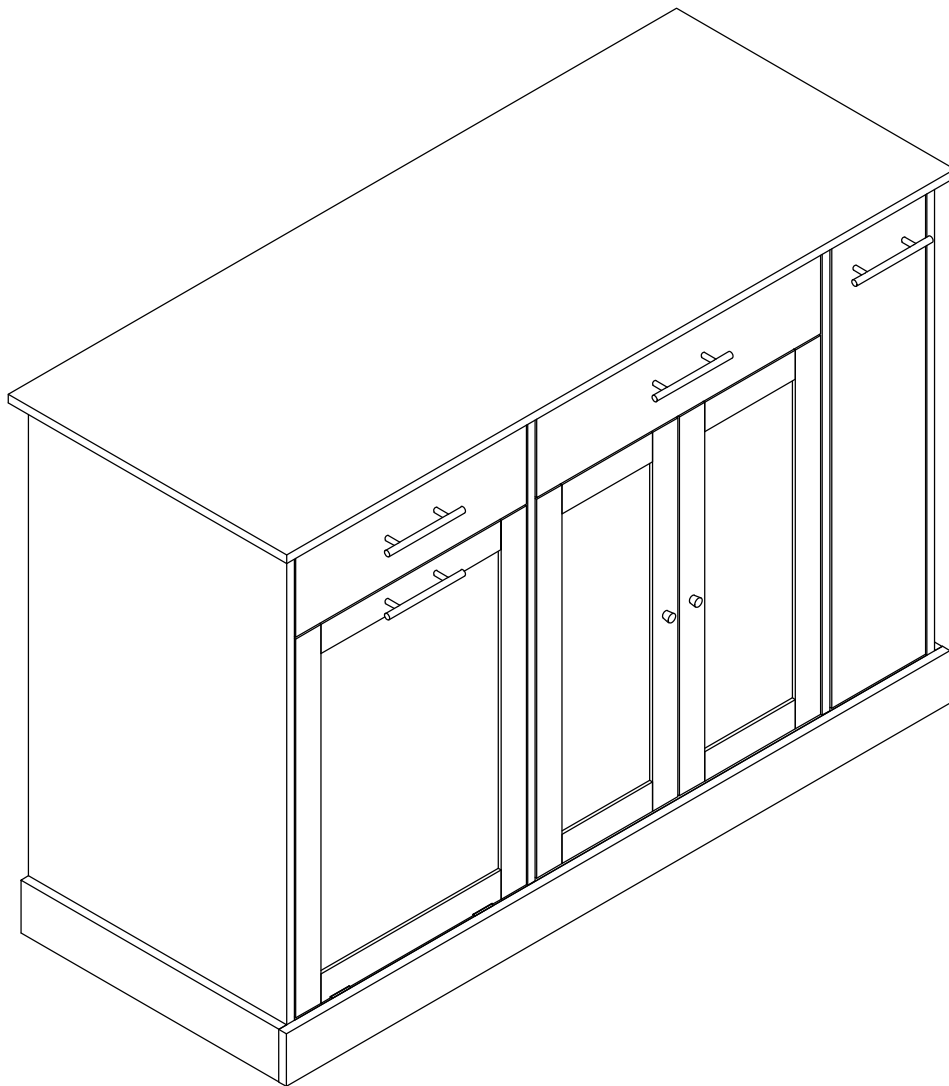

Please Make sure every screw is locked

Door Hinge Adjustment Instructions

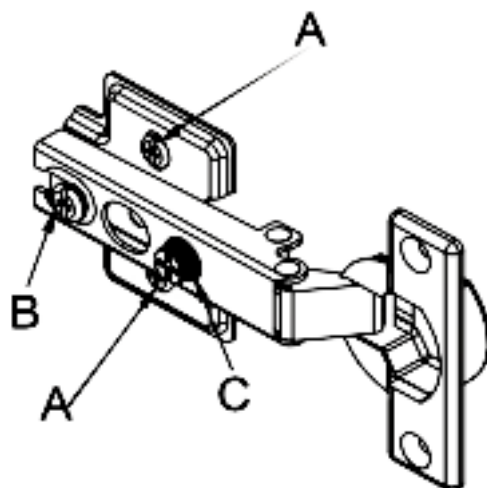

To adjust the vertical height.

Loosen the two screws "A" on hinges. Usually in slotted holes which allows you to adjust up or down by a few mm. Then tighten back.

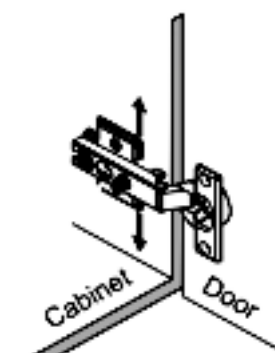
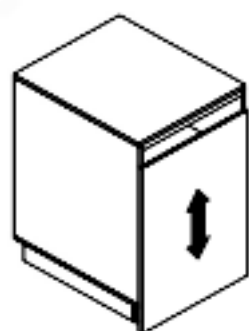

To adjust depth.

Loosen screw "B" and adjust door, if the door can not be adjusted, please loosen screw "C", then try again. Tighten screw "B" and "C".

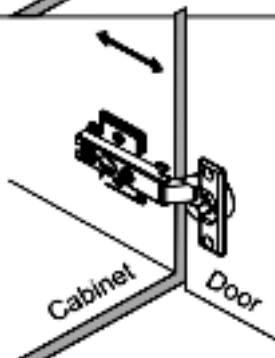
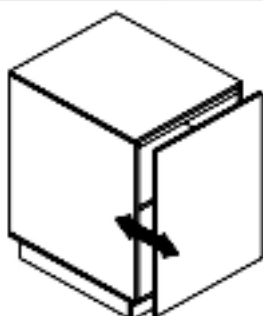

To adjust side ways.

Turning the screw "C" on BOTH hinges on each door.

