

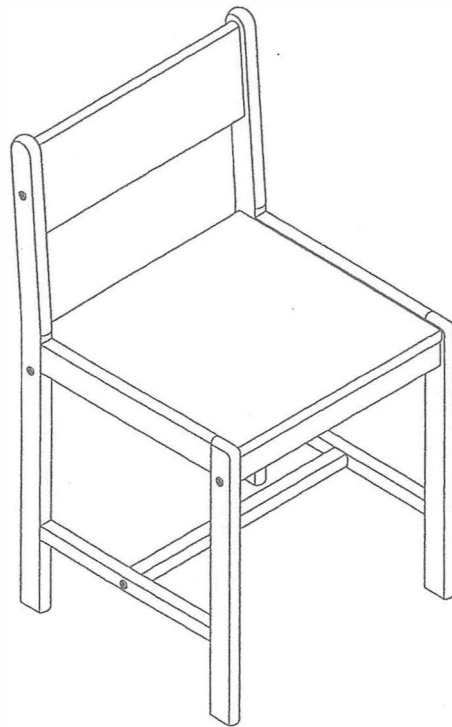







ASSEMBLY INSTRUCTION



HARDWARE LIST

<p>A</p>  <p>8 PCS</p> <p>DOWEL (M8 x 30MM)</p>	<p>B</p>  <p>8 PCS</p> <p>JCBC BOLT (M6 x 60MM)</p>	<p>C</p>  <p>8 PCS</p> <p>JRN NUT (M6 x 13MM)</p>
<p>D</p>  <p>4 PCS</p> <p>CSK C/B SCREW (M4 x 32MM)</p>	<p>E</p>  <p>1 PC</p> <p>ALLEN KEY (M4 x 60MM)</p>	<p><i>Tool Required :</i> Crosshead Screw Driver</p>

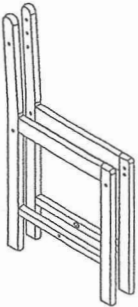
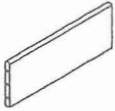
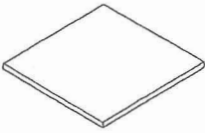
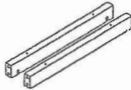
PARTS LIST

 <p>SIDE FRAME 2 PCS / SET (CARTON 1 OF 1)</p>	 <p>BACK REST 1 PC / SET (CARTON 1 OF 1)</p>	 <p>SEATER 1PC / SET (CARTON 1 OF 1)</p>	 <p>TOP RAIL 2 PCS / SET (CARTON 1 OF 1)</p>	 <p>BOTTOM RAIL 1 PC / SET (CARTON 1 OF 1)</p>
--	--	--	--	--

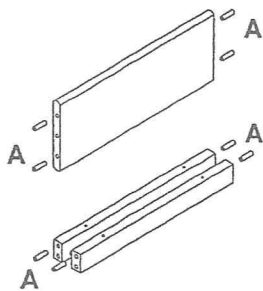

STEP 1
 Attach (A) into Back Rest and Top Rails.

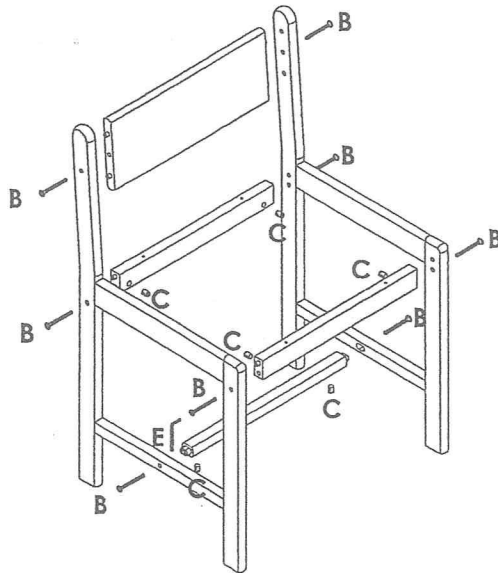

STEP 2
 Attach Back Rest and Rails to Side Frame by using (B) and (C), tighten it up by using (E).

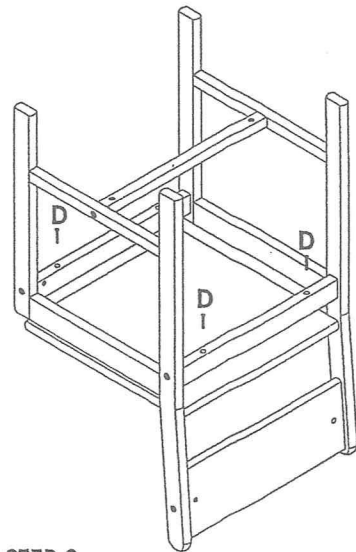

STEP 3
 Attach Seater to the Top Rails by using (D), tighten it up by using a Crosshead Screw Driver.