

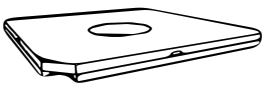

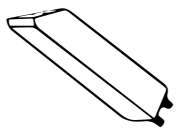

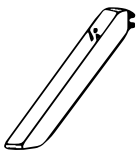





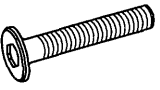

# ASSEMBLY INSTRUCTION

## DINING TABLE 46"-60" WITH LEAF

|   |   |   |  |
|---|---|---|--|
| <b>A</b> TABLE TOP WITH LEAF<br><br>1 PC   | <b>B</b> UPPER BASE<br><br>4 PCS                     | <b>C</b> BOTTOM BASE<br><br>4 PCS               | <b>D</b> BOTTOM BAR<br><br>1 PC               |
| <b>E</b> UPPER BAR<br><br>1 PC             | <b>F</b> SLAT SUPPORT<br><br>4 PCS                   | <b>G</b> ALLEN WRENCH<br>M4 x 100MM<br><br>1 PC | <b>H</b> JCBC BOLT<br>M6 x 70MM<br><br>12 PCS |
| <b>I</b> SPRING WASHER<br>M6<br><br>12 PCS | <b>J</b> SPANNER<br>13MM<br><br>1 PC                 | <b>K</b> HEX NUT<br>M8<br><br>8 PCS             | <b>L</b> SPRING WASHER<br>M8<br><br>8 PCS     |
| <b>M</b> FLAT WASHER<br>M8<br><br>8 PCS   | <b>N</b> WAFERHEAD SCREW<br>M4 x 25MM<br><br>25 PCS | <b>O</b> LEVELER<br>M6 x 23MM<br><br>4 PCS     | <b>P</b> WOOD CAP<br><br>1 PC                |
| <b>Q</b> METAL BARREL<br><br>1 PC        |   |   |  |

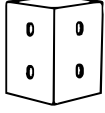
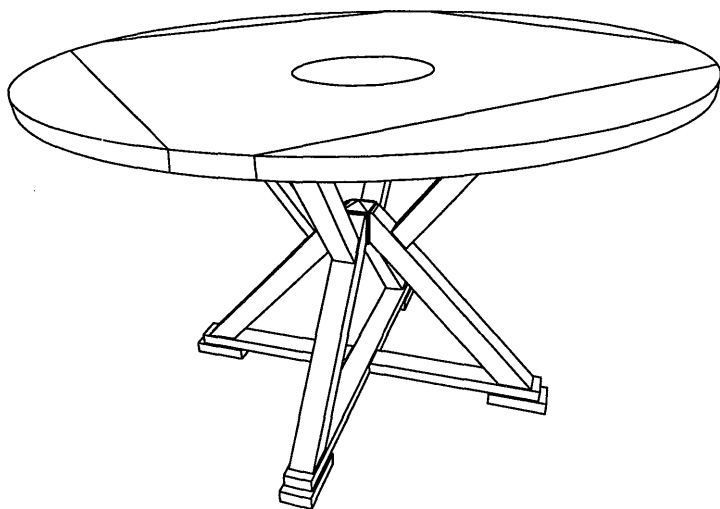

This page lists all the contents included in the box. Please take the time to identify the hardware as well as the individual components to this product. As you unpack and prepare for assembly, place the contents on a carpeted or padded area to protect them from damage.

- 1** Using the bottom wood dowel as a guide, align and attach one Upper Base (B) to the Bottom Base (C) using JCBC Bolt (H), Spring Washer (I) and tighten with Allen Wrench (G).

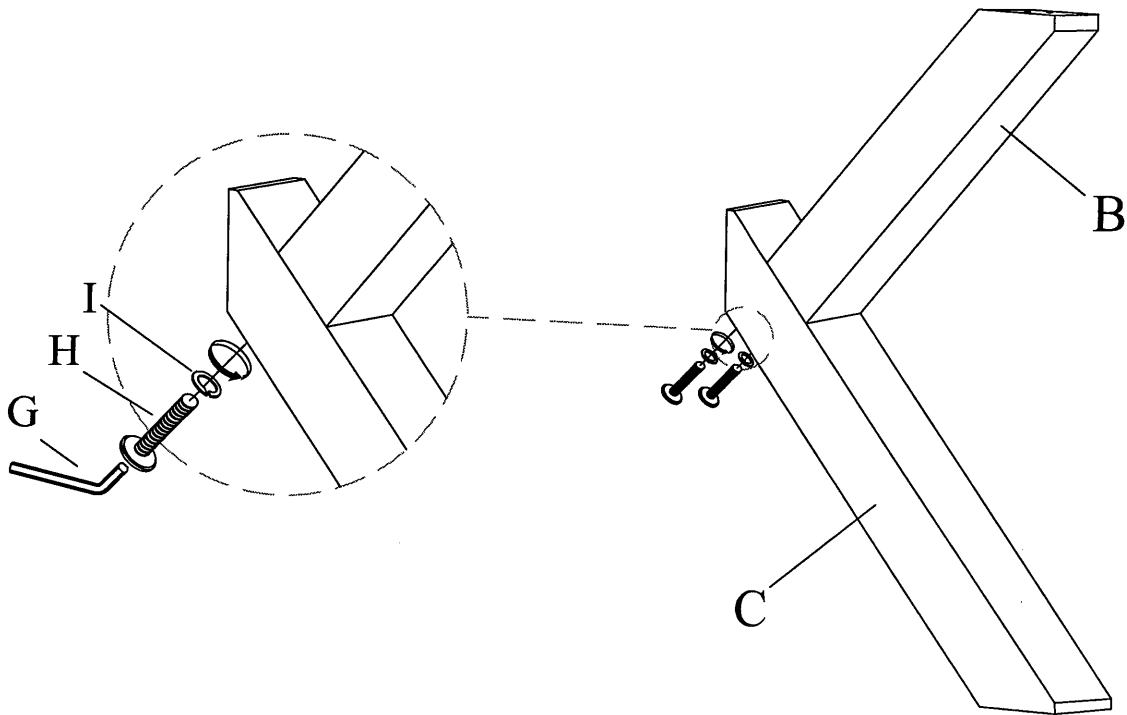

- 2** (i) Attach last assemblies to the Metal Barrel (Q) by using Hex Nut (K), Spring Washer (L) and Flat Washer (M). Please tighten the Hex Nut (K) using Spanner (J). Please make sure the leg is aligned with Metal Barrel (Q).  
(ii) Attach Slat Support (F) to the top of the Upper Base (B) using Waferhead Screw (N). Make sure it is centred properly and tighten with screw driver (not provided).

**\*\* Do not fully tighten all the bolts at this step. (Fully tighten the bolt after step 4)**

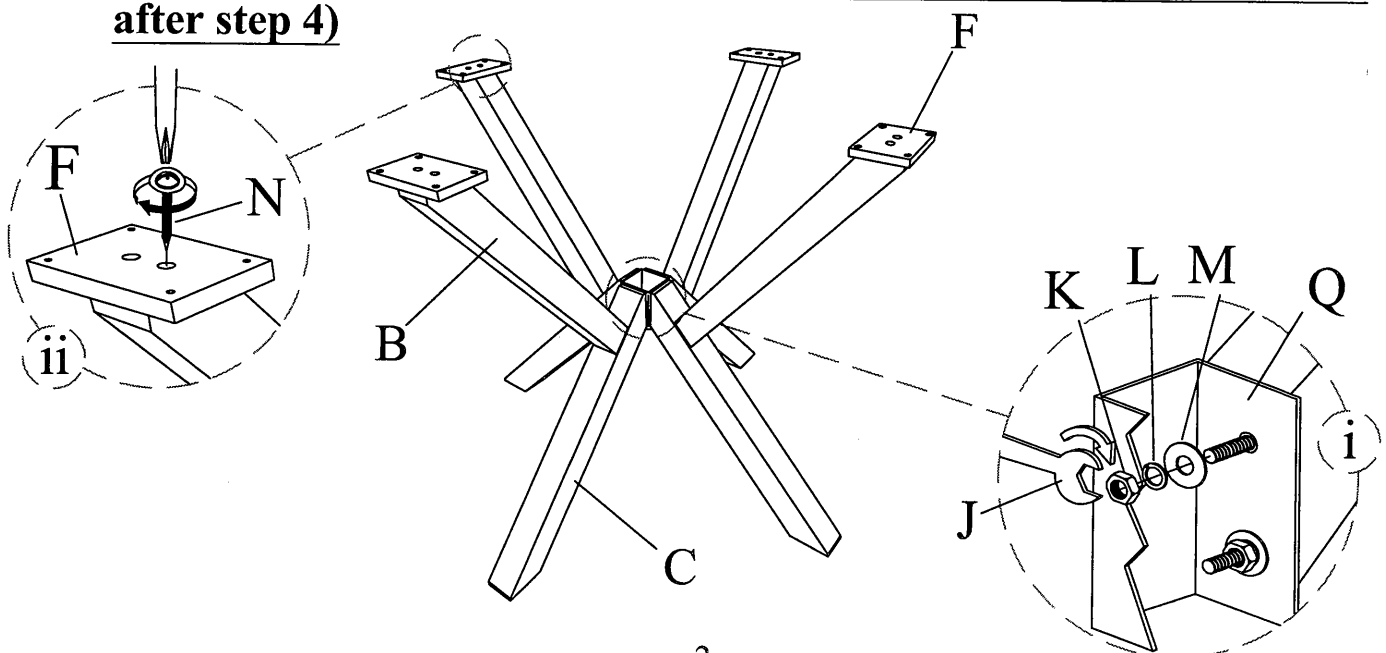

- 3** Place Table Top (A) upside down on soft surface. Align and fasten Slat Support (F) to the marking on Table Top (A) by using Waferhead Screw (N) and tighten with screw driver (not provided).

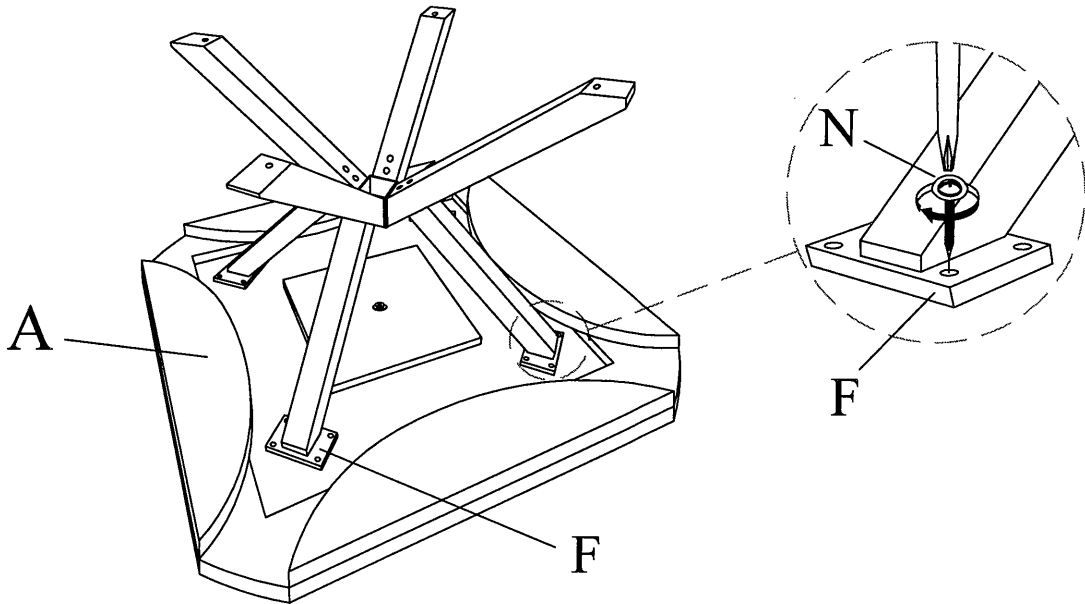

- 4** (i) Align and fasten Bottom Bar (D) and Upper Bar (E) to table leg using JCBC Bolt (H) and Spring Washer (I) and tighten with Allen Wrench (G). Do not tighten the bolt until all bolts are attached.  
(ii) Attach Upper Bar (E) and Bottom Bar (D) by using Waferhead Screw (N) and tighten with screw driver (not provided).  
(iii) Screw in the Leveler (O) in to the Bottom Bar (D) and Upper Bar (E).  
**\*\* Fully tighten all the bolts at this step. (Included all bolts at step 2)**

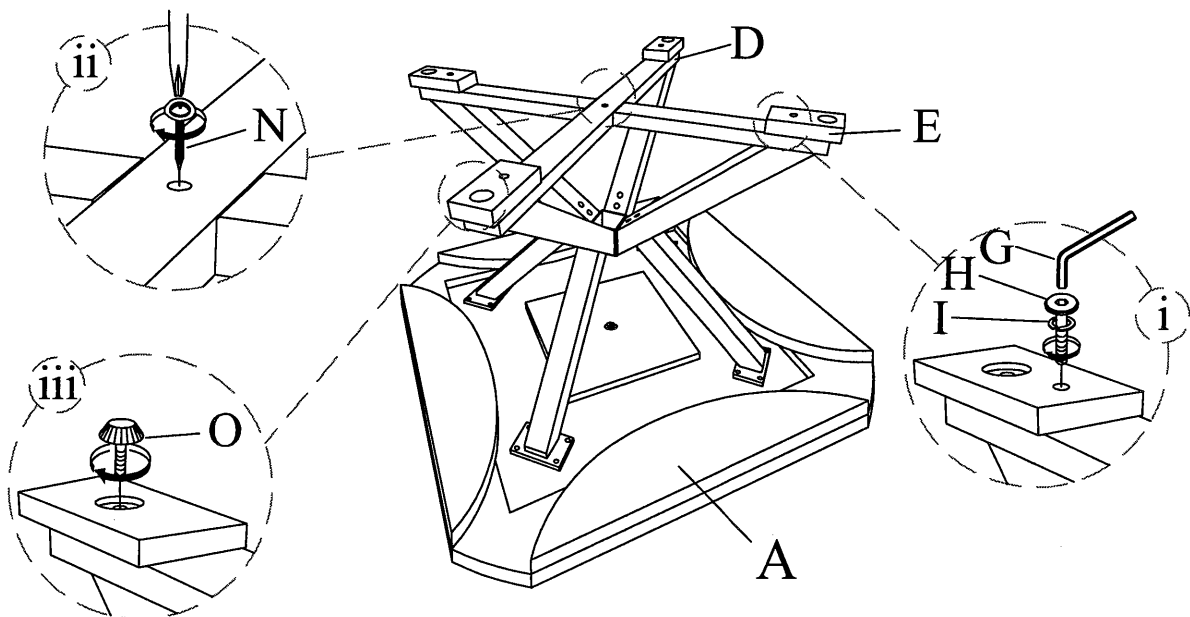

- 5** Cover the Metal Barrel (Q) by inserting the Wood Cap (P). Stand table up on the flat surface and check that it is balanced. If there is slight wobble, please adjust the leveler.

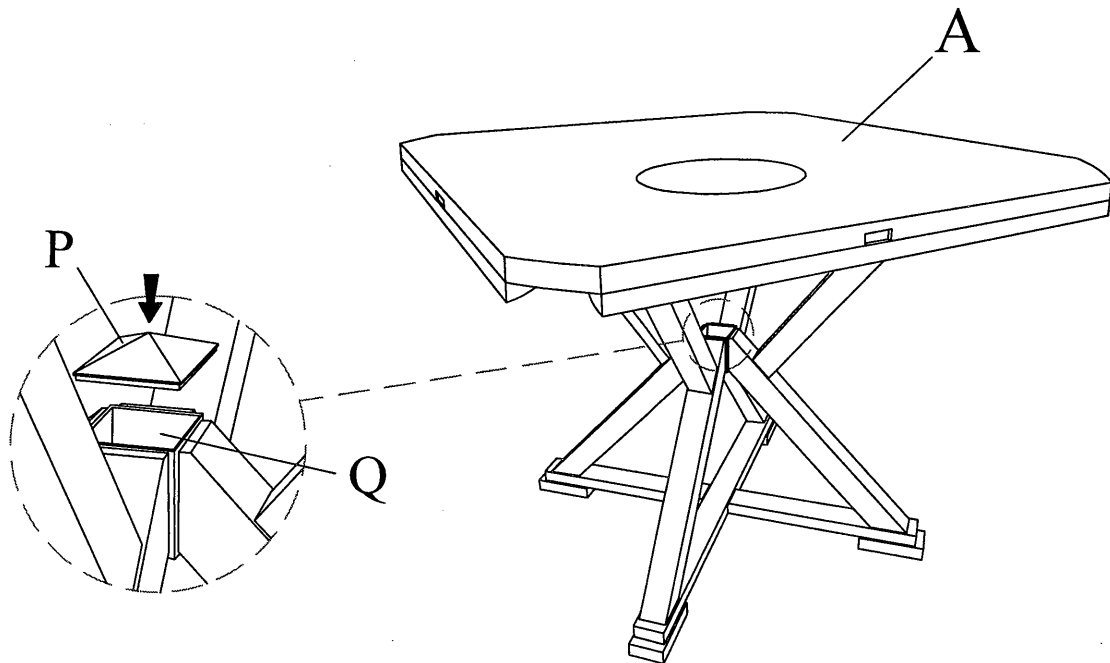

- 6** (i) Lift up the leaf and pull out the wood support which underneath of table top till fixed and tight.  
(ii) Unloose the JCBC Bolt (H) underneath the lazy susan.

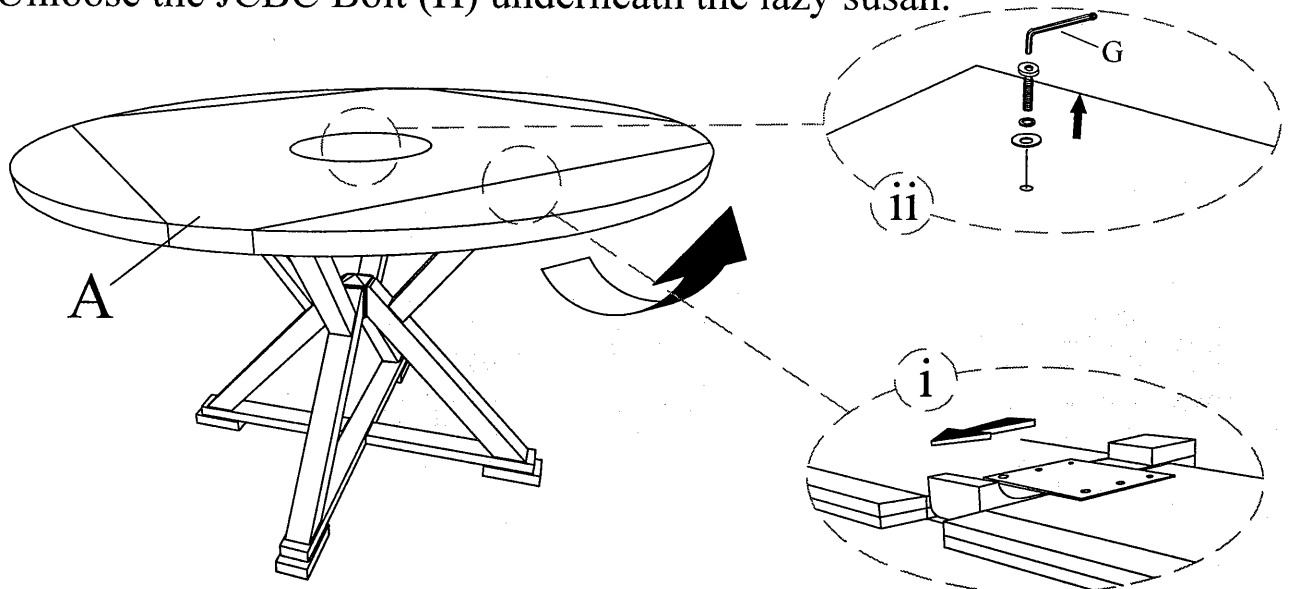

#### Cleaning & Care

Treat Surface with care. Surface is resistant to scratches but is not scratch resistant. Clean surface with a dry or damp soft cloth. Do not use abrasive cleaners. Hardware may loosen over time. Periodically check that all connections are tight.