

# User's Manual

---

## Sofa

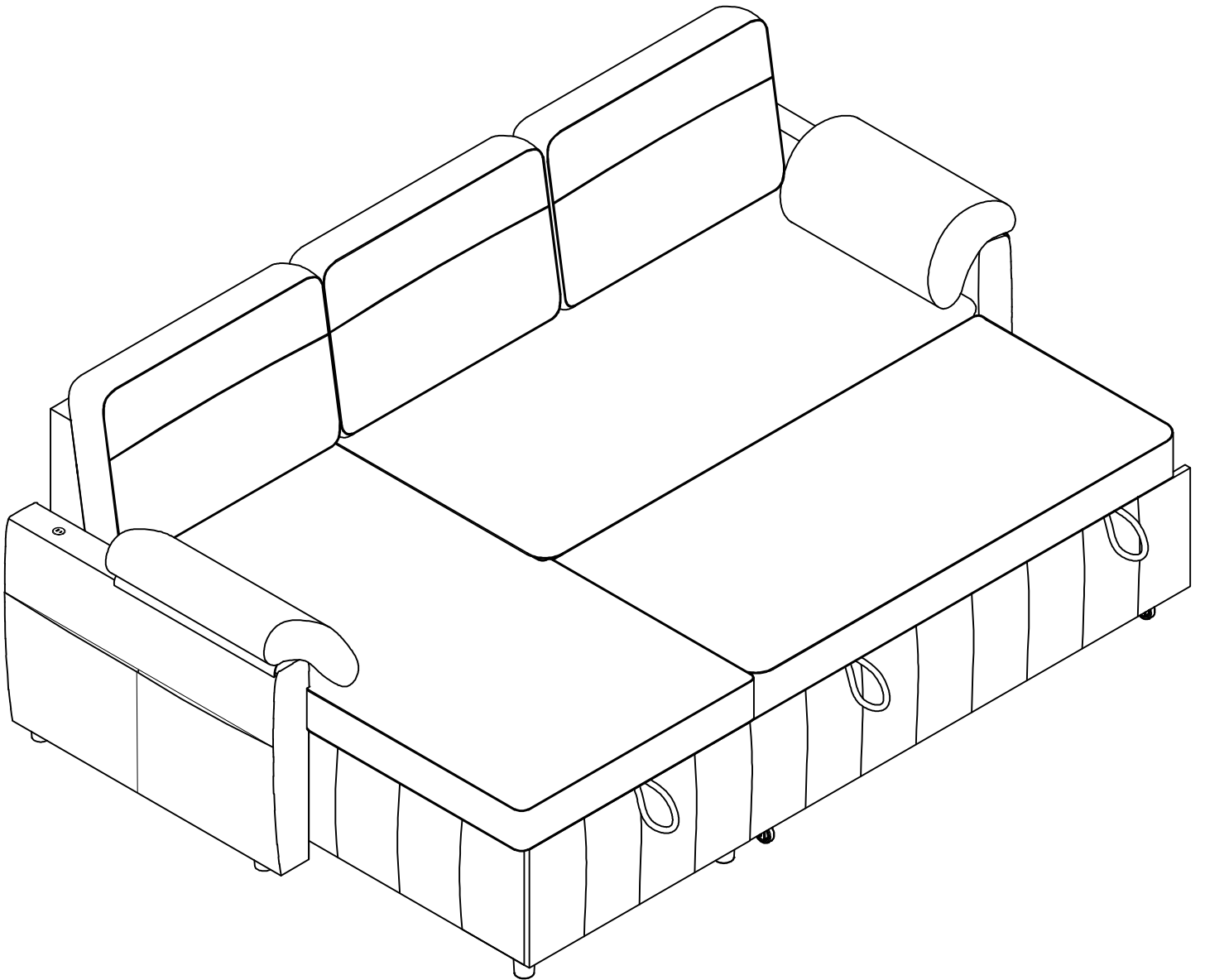



# Safety and Care Advice

**Important - Please read these instructions fully before starting assembly**

**Thanks for your purchase. Before assembling, please follow the instructions to check if all the spare parts and screws are intact.**

- Considering the size and weight of the sofa, we recommend two adults to assemble the sofa, on a carpeted or padded area, in the room that it is intended for. Approximate assembly time: 30 minutes.
- Please do not throw away any of the packaging or the instruction until you have checked all the components and hardware and the furniture is fully assembled. Please ensure that the packaging is disposed in a safe and environmentally friendly way.
- Keep all components and packaging out of reach of children or animals to avoid the risk of choking or suffocation.
- Please do not take off the cover, and do not wash.

**Your cushions come vacuum packed and sealed for shipping. To restore the cushion's original shape, follow the steps below.**

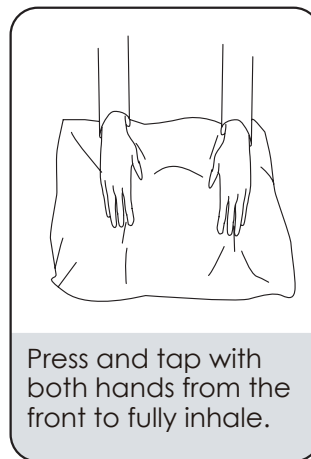
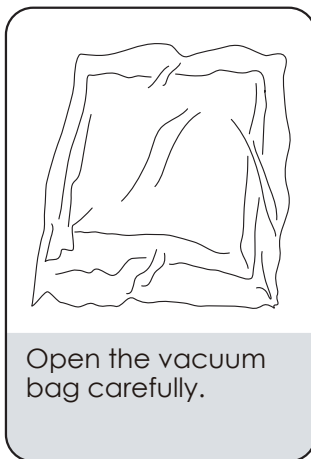

**Recovery takes 48 hours and requires tapping the backrest.**

## Attention:

1. Please install other parts first, and then open the compressed backrest and seat cushion.
2. Be careful not to scratch the product when opening the compressed package.
3. The sponge is expected to recover in 48 hours, and you can speed up the recovery by patting the backrest.

### Assembly Option ①

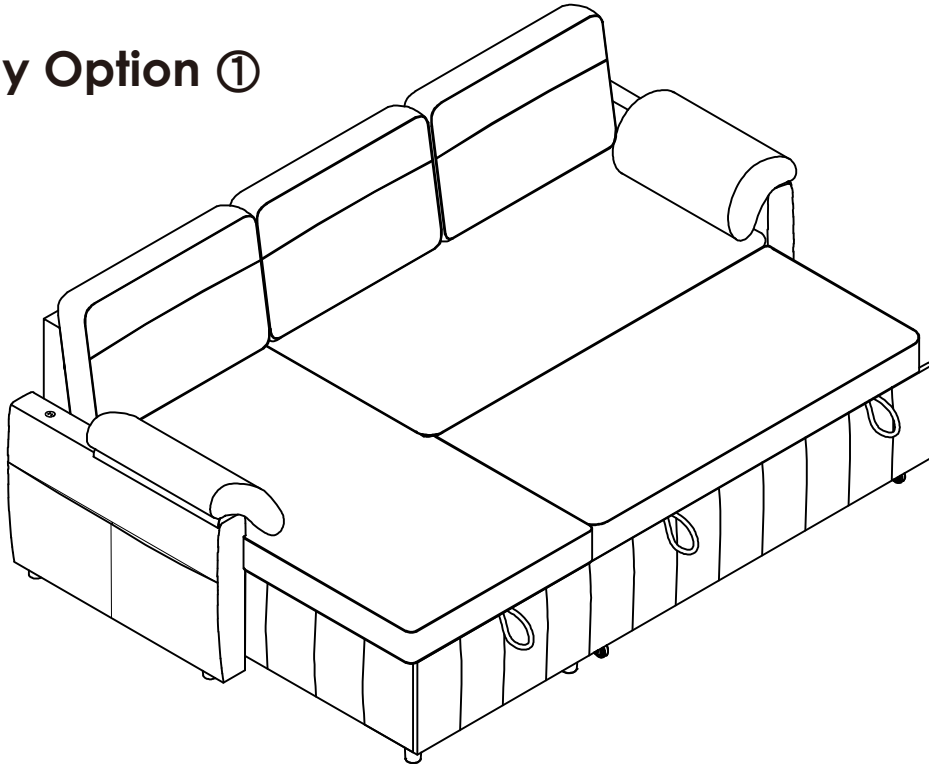

### Assembly Option ②

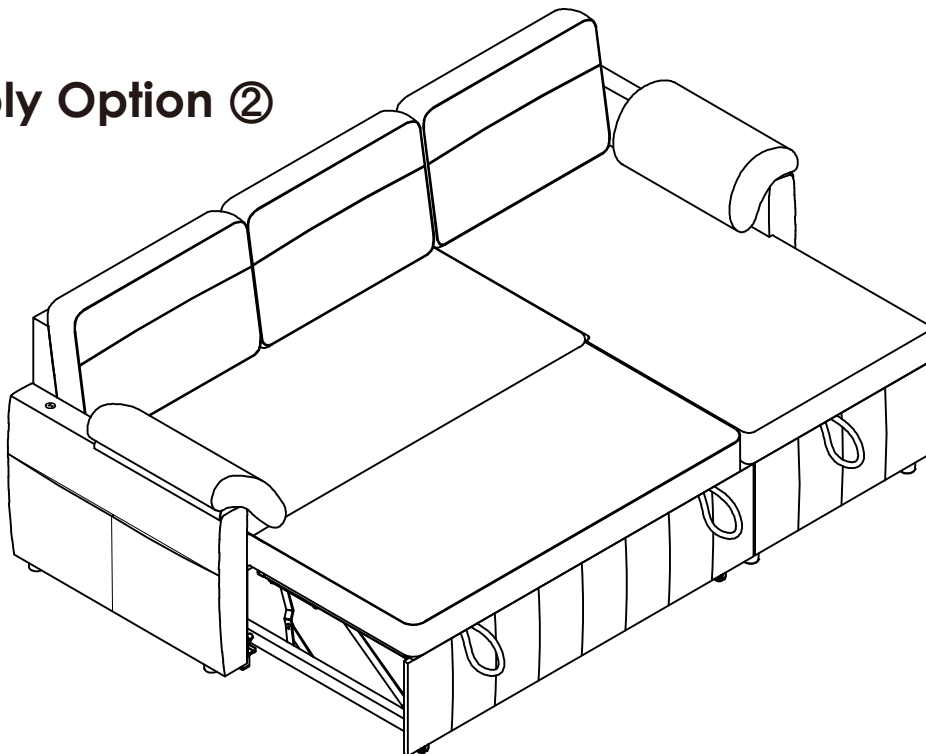

# Main Structure Accessories

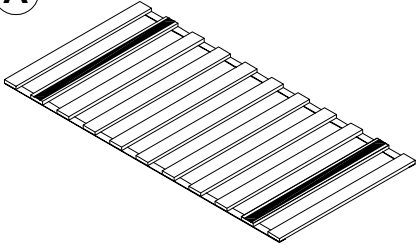
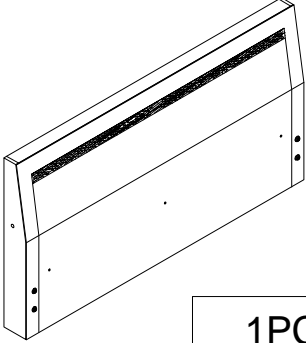
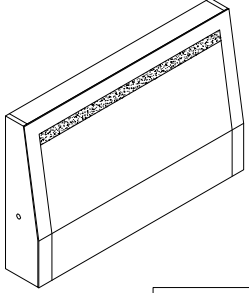
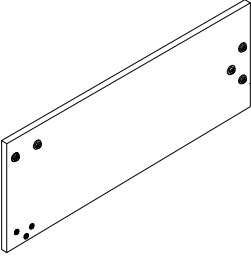
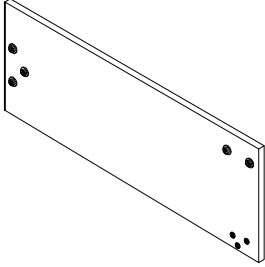
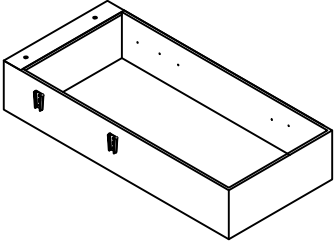
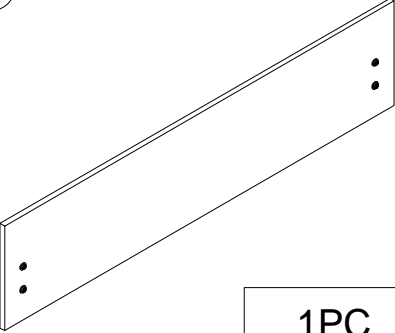
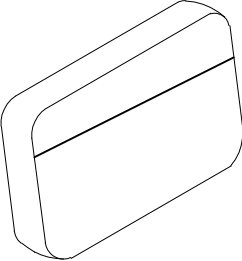
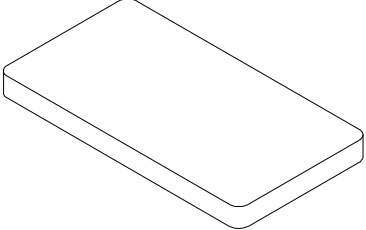
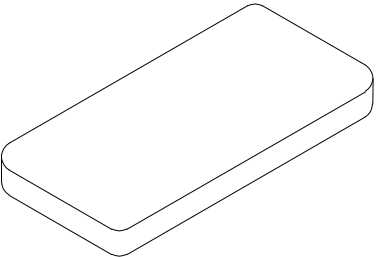
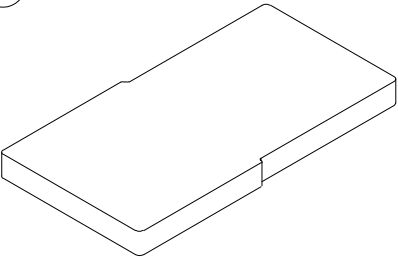
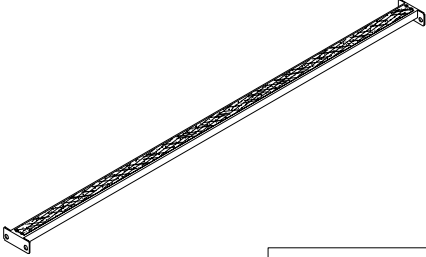
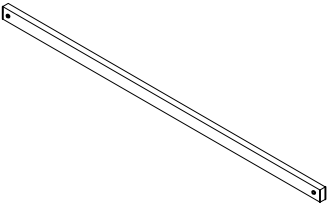
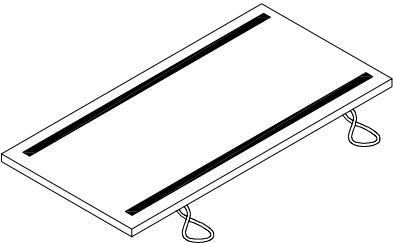
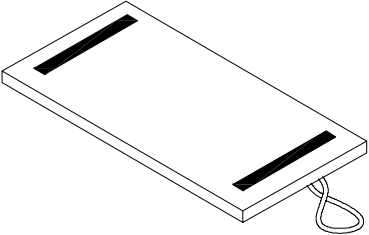
<p><b>A</b></p>  <p>1PC</p>	<p><b>C</b></p>  <p>1PC</p>	<p><b>C1</b></p>  <p>1PC</p>
<p><b>D</b></p>  <p>1PC</p>	<p><b>D1</b></p>  <p>1PC</p>	<p><b>D2</b></p>  <p>1PC</p>
<p><b>E</b></p>  <p>1PC</p>	<p><b>F</b></p>  <p>3PCS</p>	<p><b>F1</b></p>  <p>1PC</p>
<p><b>F2</b></p>  <p>1PC</p>	<p><b>F3</b></p>  <p>1PC</p>	<p><b>G</b></p>  <p>1PC</p>
<p><b>G1</b></p>  <p>1PC</p>	<p><b>H</b></p>  <p>1PC</p>	<p><b>H1</b></p>  <p>1PC</p>

# Main Structure Accessories

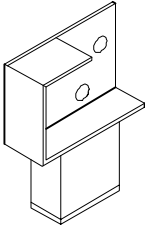
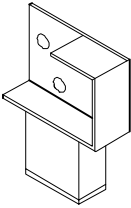
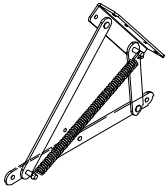
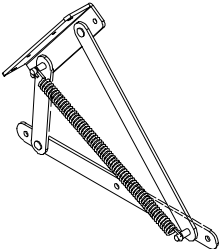
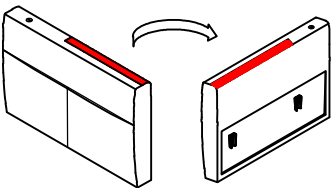
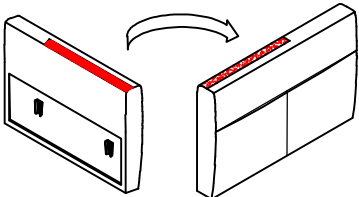
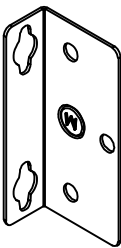
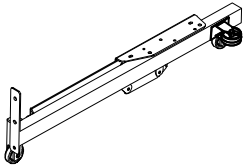
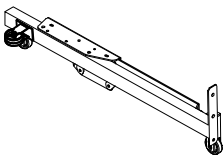
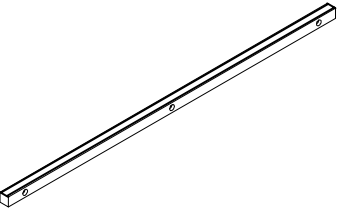
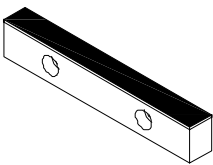
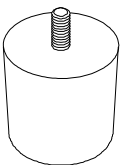
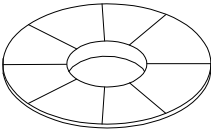
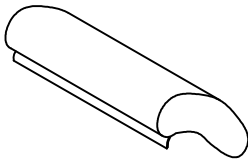
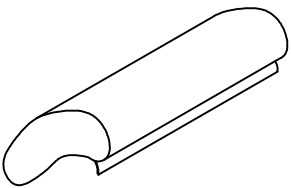
<p><b>J</b></p>  <p>1PC</p>	<p><b>J1</b></p>  <p>1PC</p>	<p><b>L</b></p>  <p>1PC</p>
<p><b>L1</b></p>  <p>1PC</p>	<p><b>R1</b></p>  <p>1PC</p>	<p><b>R2</b></p>  <p>1PC</p>
<p><b>W</b></p>  <p>2PCS</p>	<p><b>S</b></p>  <p>1PC</p>	<p><b>S1</b></p>  <p>1PC</p>
<p><b>Z</b></p>  <p>1PC</p>	<p><b>Z2</b></p>  <p>3PC</p>	<p><b>M</b></p>  <p>10PCS</p>
<p><b>M2</b></p>  <p>10PCS</p>	<p><b>(F5-R1)</b></p>  <p>1PC</p>	<p><b>(F5-R2)</b></p>  <p>1PC</p>

# Hardware Parts

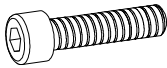
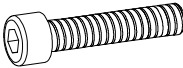
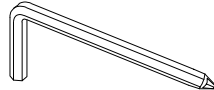
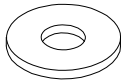
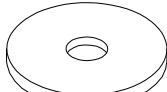
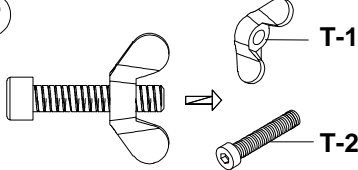
<p><b>(N)</b></p>  <p>M8x30mm</p> <p style="text-align: right;">11+1PCS</p>	<p><b>(N1)</b></p>  <p>M8x45mm</p> <p style="text-align: right;">4PCS</p>	<p><b>(P)</b></p>  <p style="text-align: right;">1PC</p>
<p><b>(P1)</b></p>  <p>Small</p> <p style="text-align: right;">11+1PCS</p>	<p><b>(P2)</b></p>  <p>Big</p> <p style="text-align: right;">6PCS</p>	<p><b>(T)</b></p>  <p>M8x50mm</p> <p style="text-align: right;">1SET</p>

# Main Structure Accessories

## CHAISE

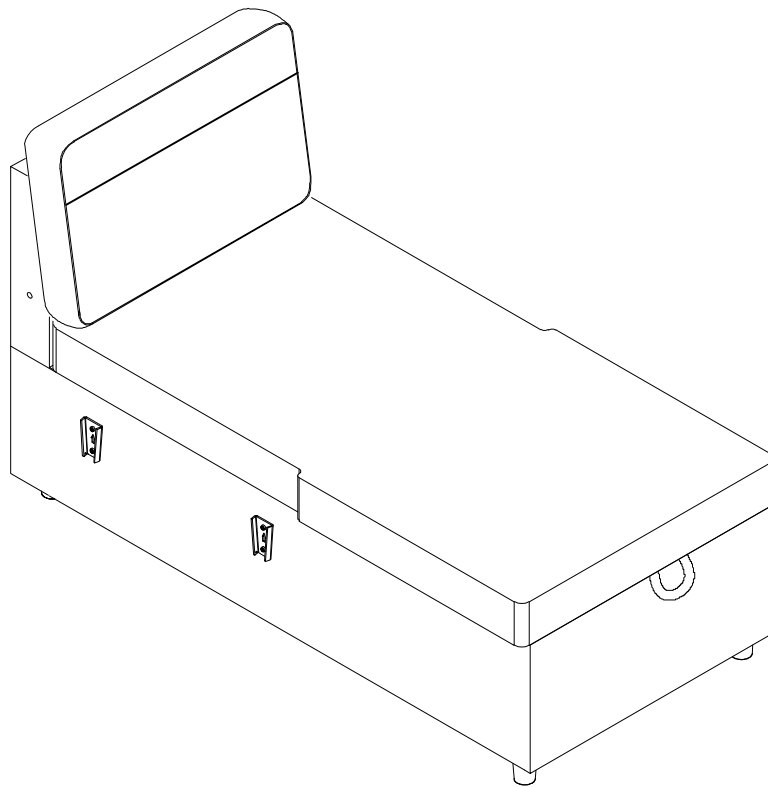
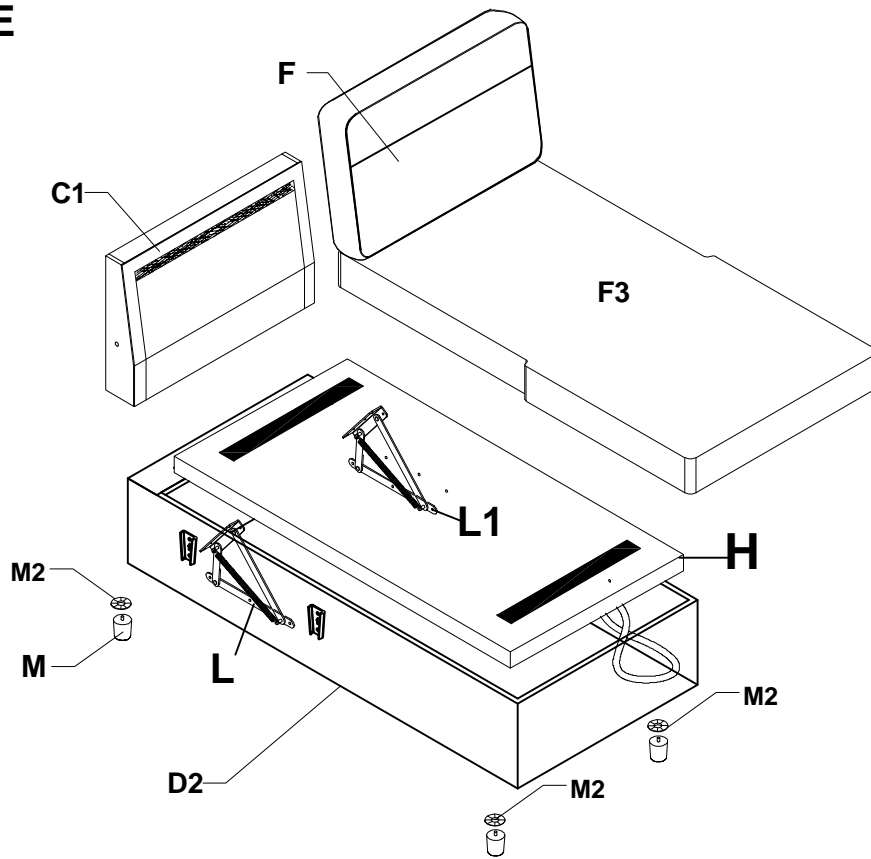

# STEP 1

How to find out  
he hidden parts

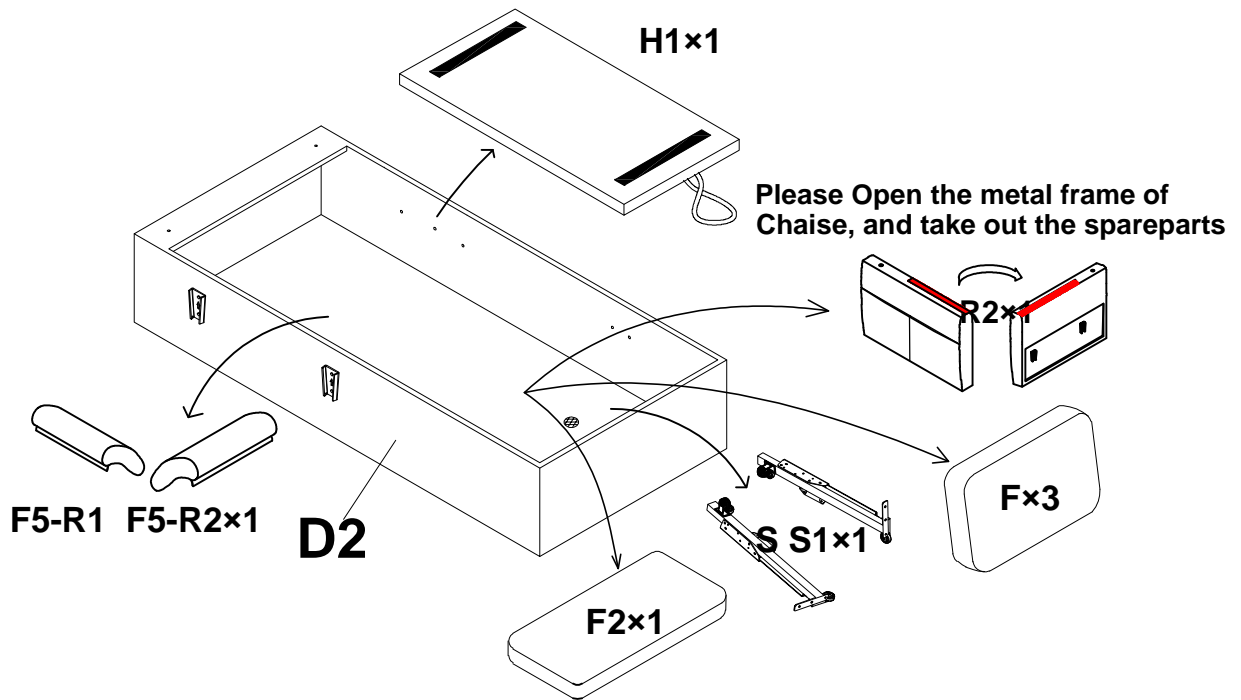

Please take out the A  
from the back of C1.

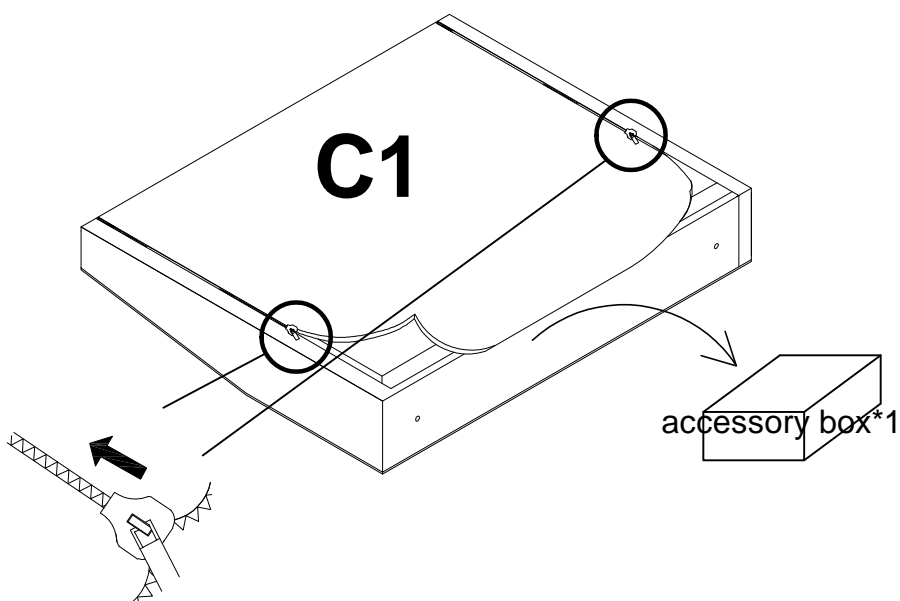



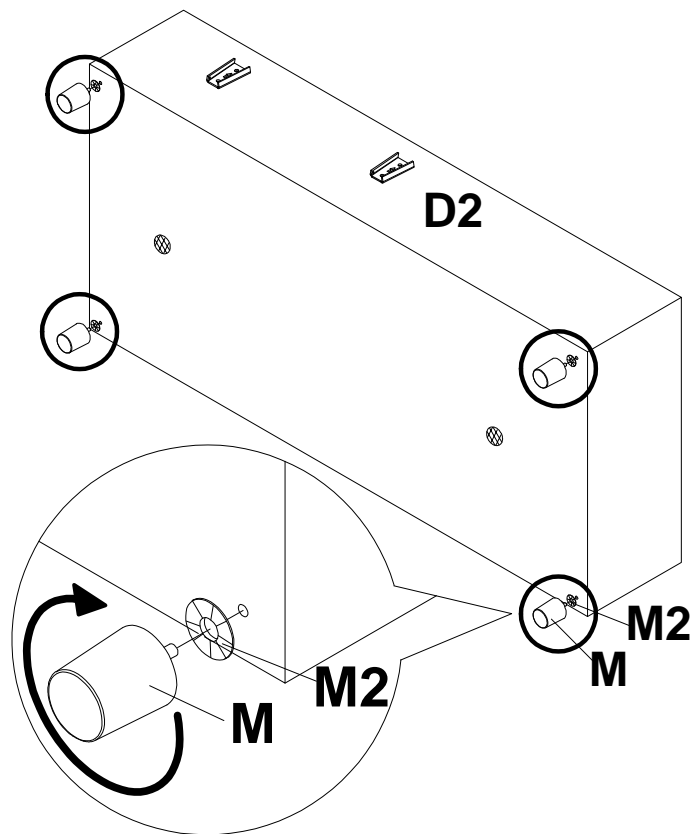

# Assembly Steps(EN) / Montageschritte(DE)

## STEP 2

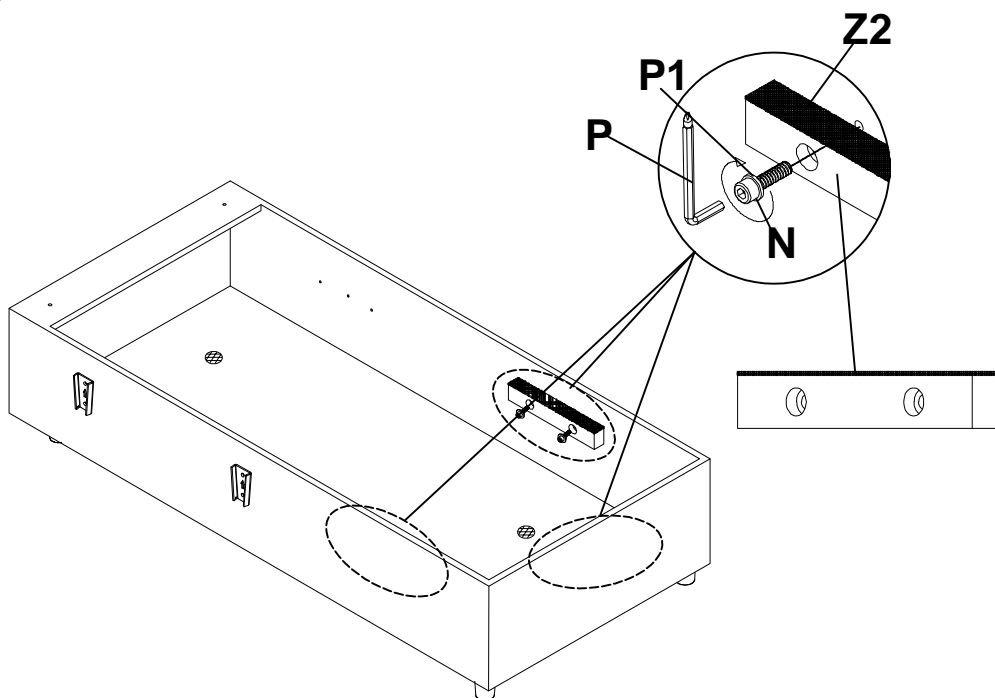

## STEP 3



	N x 6PCS
	P1 x 6PCS
	P x 1PC

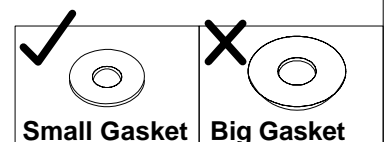

## Assembly Steps(EN) / Montageschritte(DE)

### STEP 4

Loosen the screw, align the hole, and then tighten the screw.

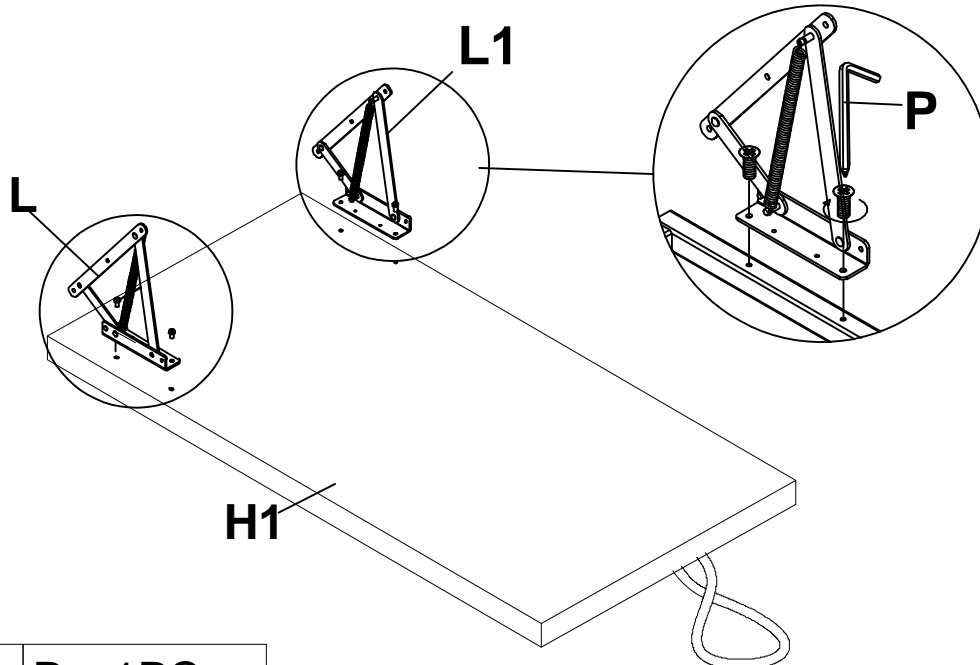

P x 1PC

### STEP 5

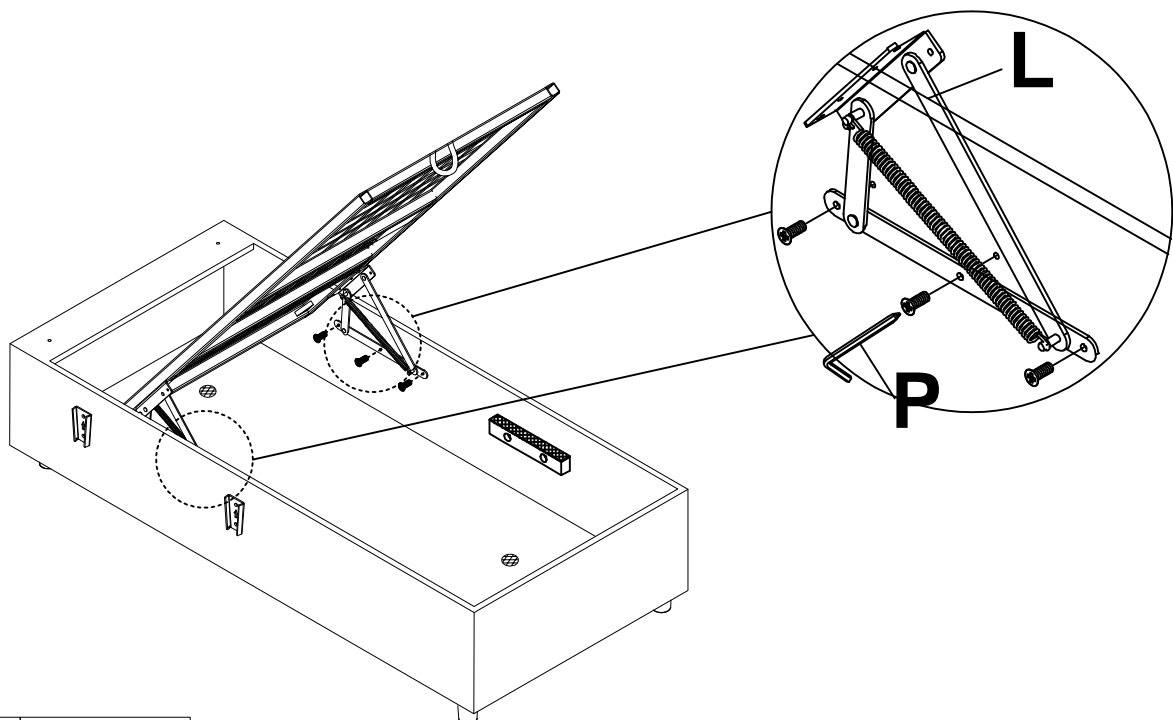

Loosen the screw, align the hole, and then tighten the screw.

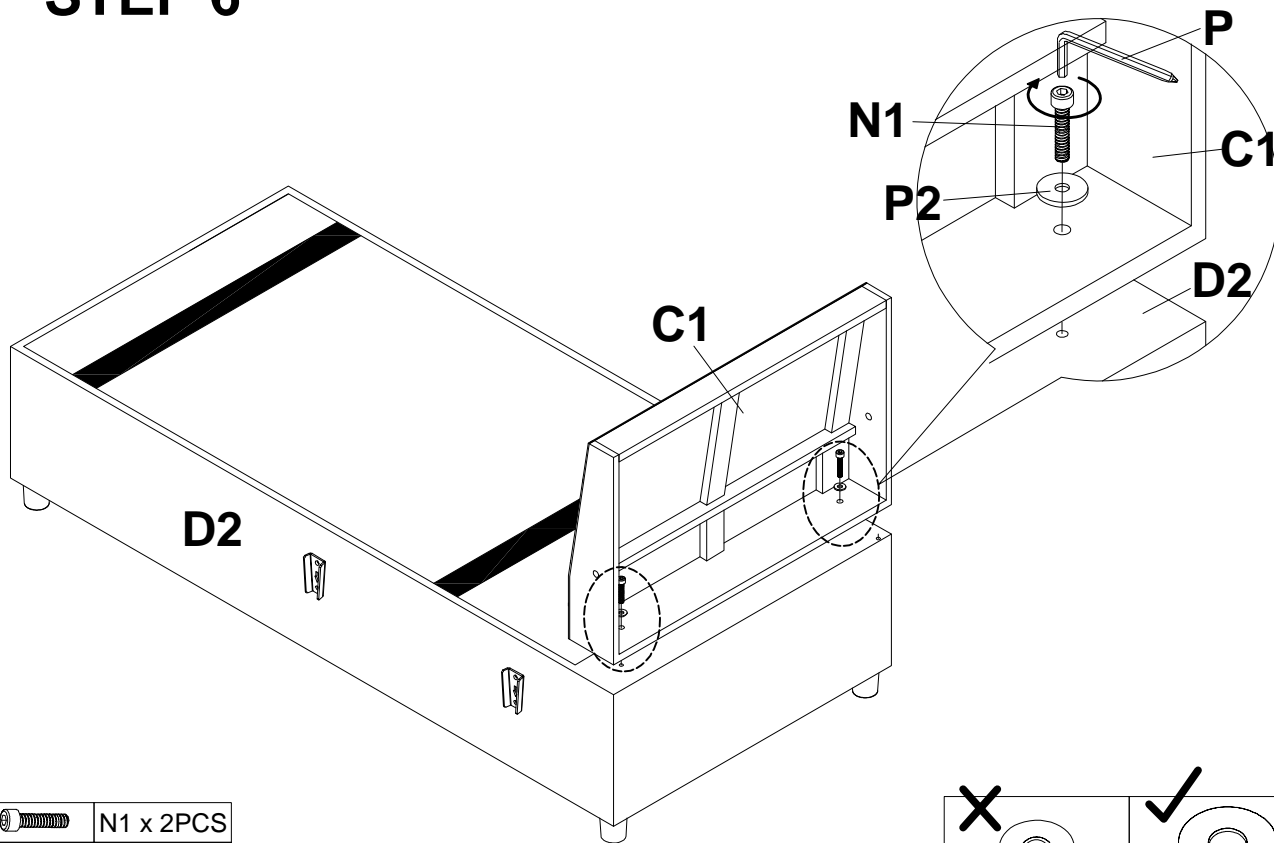

P x 1PC

# STEP 6



	N1 x 2PCS
	P2 x 2PCS
	P x 1PC

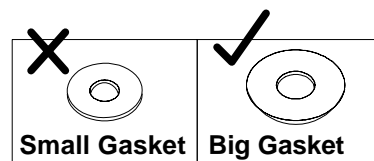

Main Structure Accessories

CHAISE

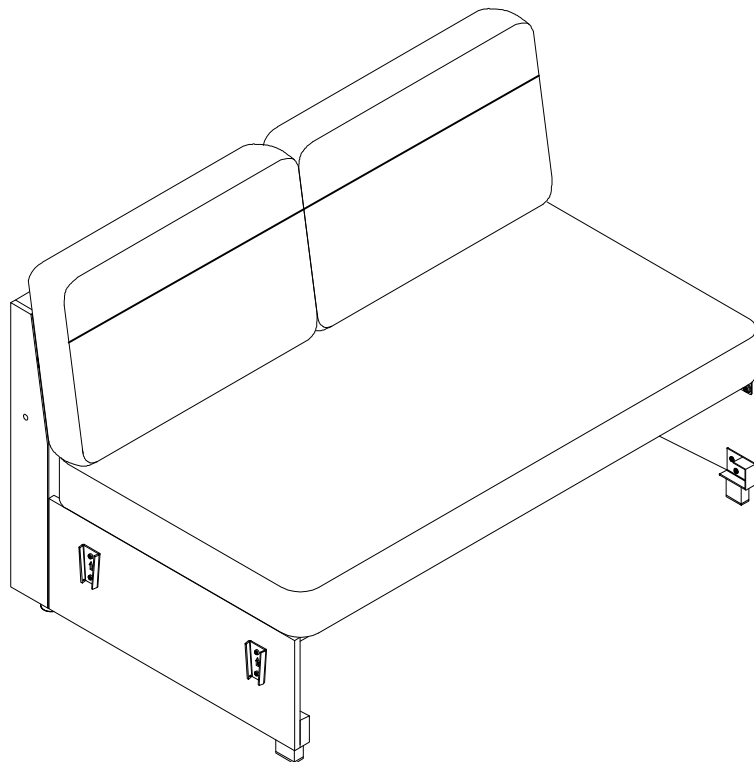
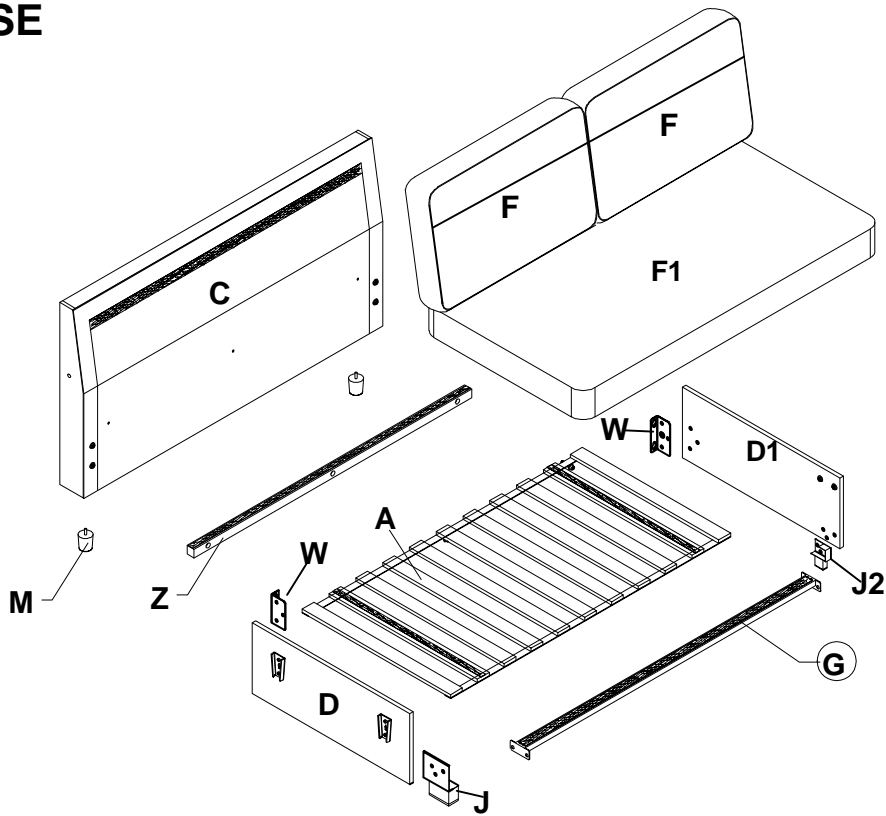

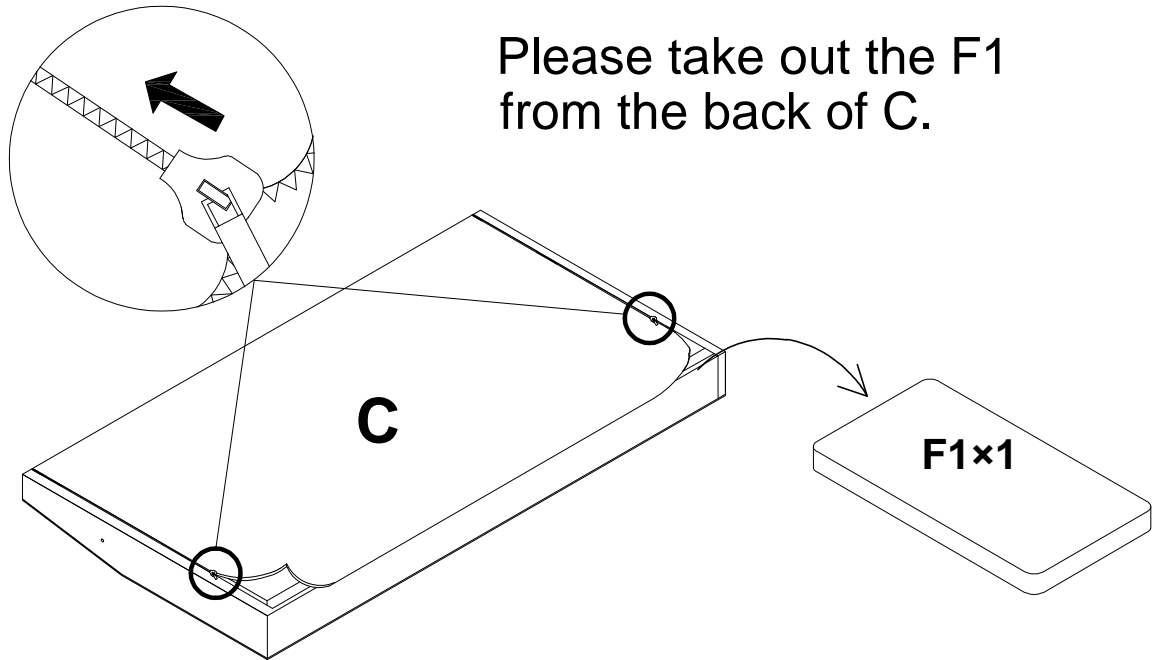

## STEP 7

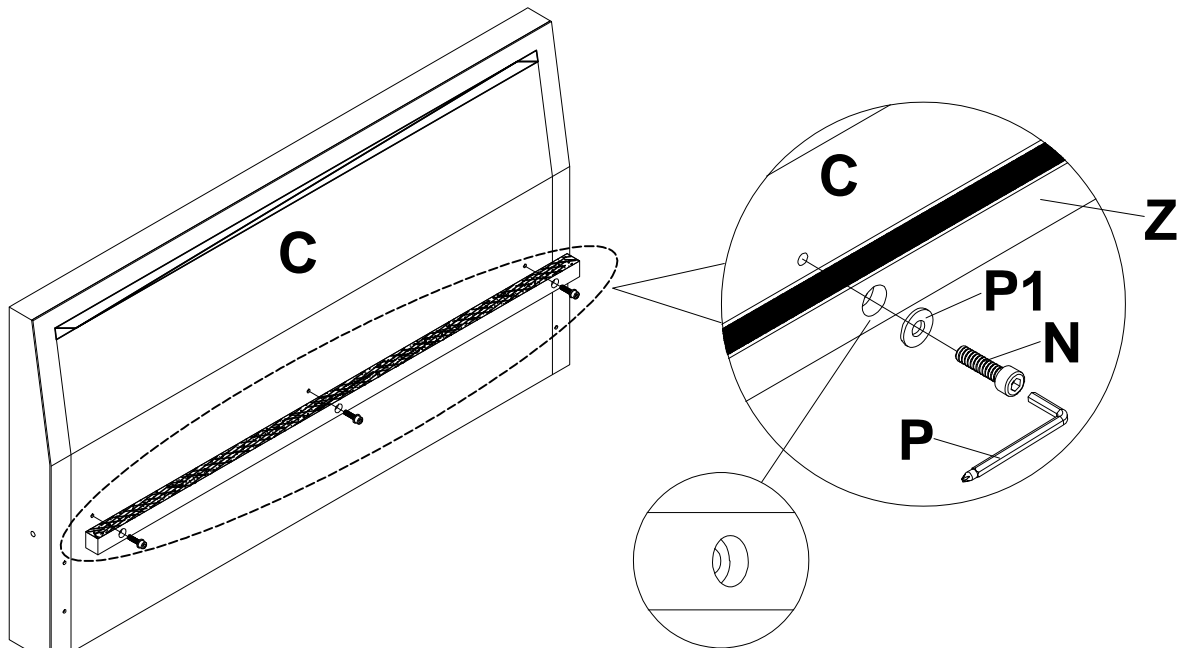

## STEP 8



Countersunk holes face outward.

	N x 3PCS
	P1 x 3PCS
	P x 1PC

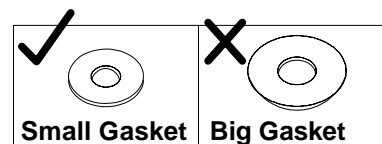



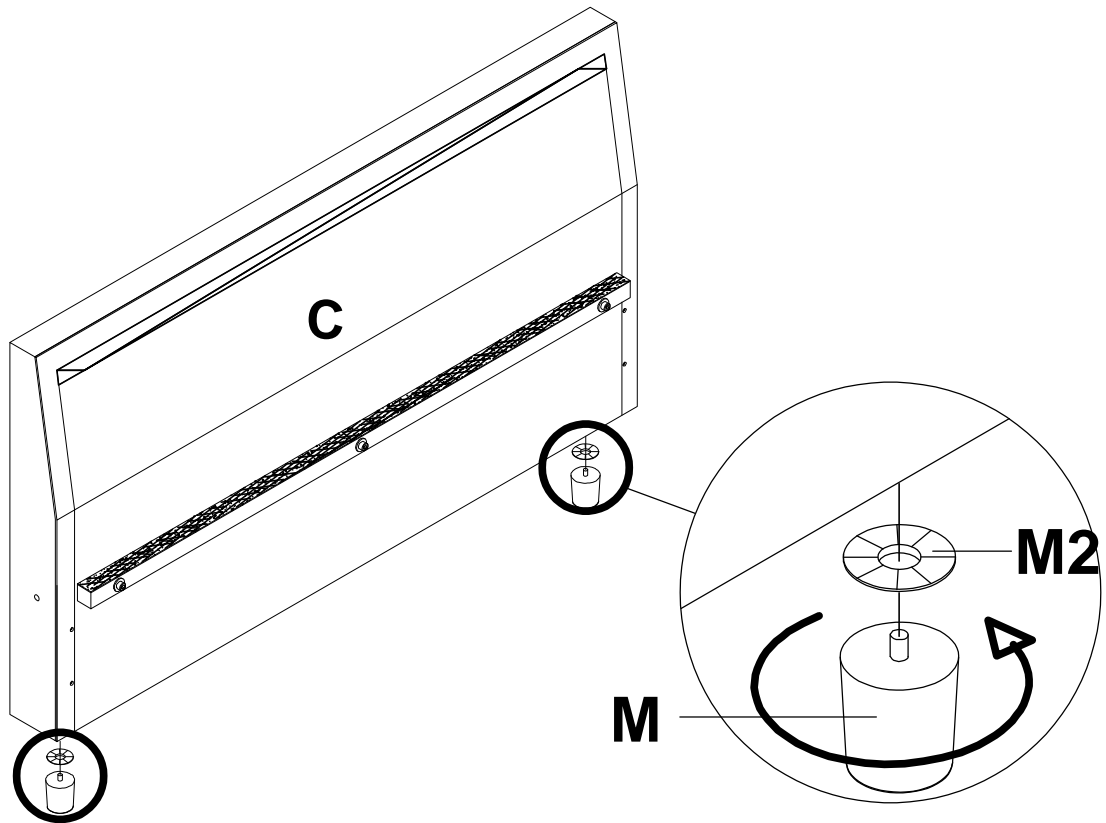

## STEP 9

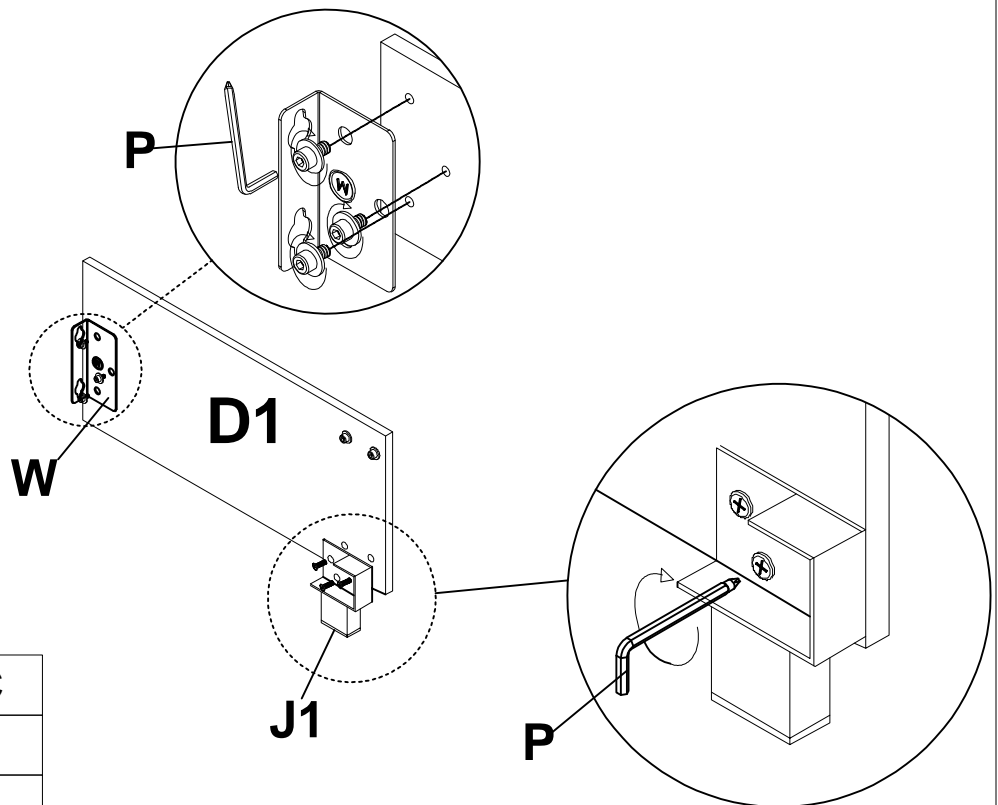

## STEP 10

Loosen the screw, align the hole, and then tighten the screw.







	J1 x 1PC
	W x 1PC
	P x 1PC

## Assembly Steps(EN) / Montageschritte(DE)

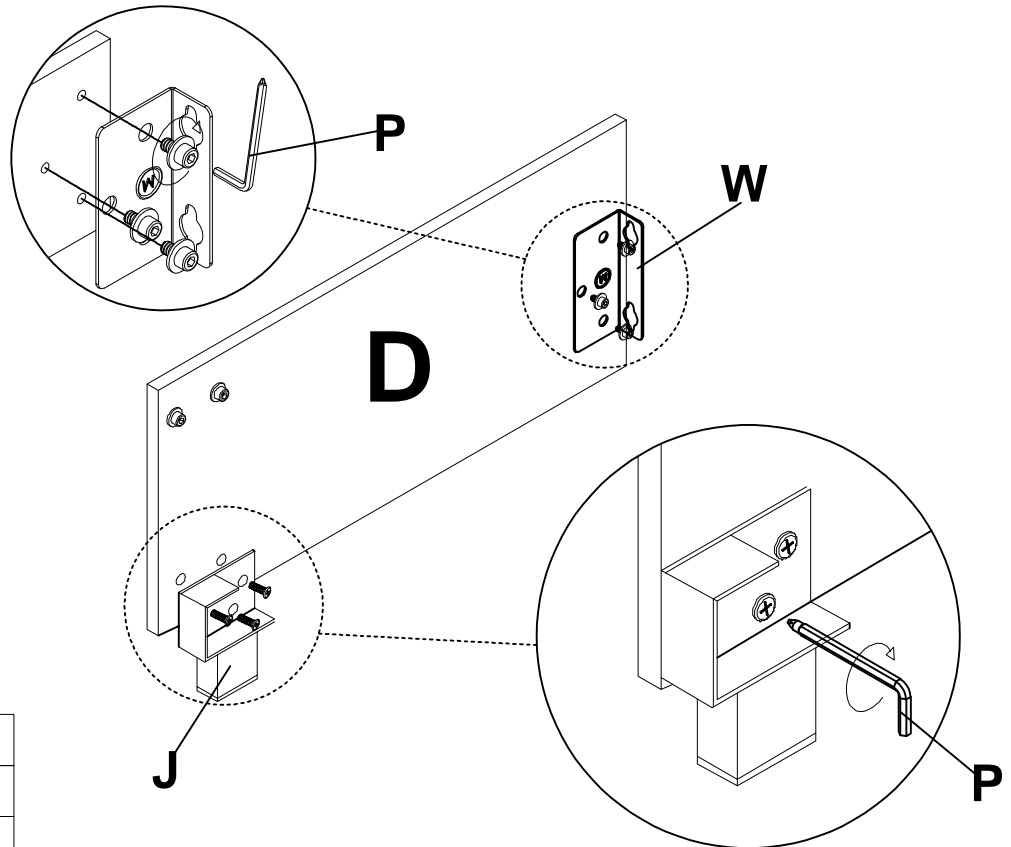
### STEP 11

Loosen the screw, align the hole, and then tighten the screw.



	J x 1PC
	W x 1PC
	P x 1PC

### STEP 12

First loosen the bolts, install D/D1 and lock the bolts

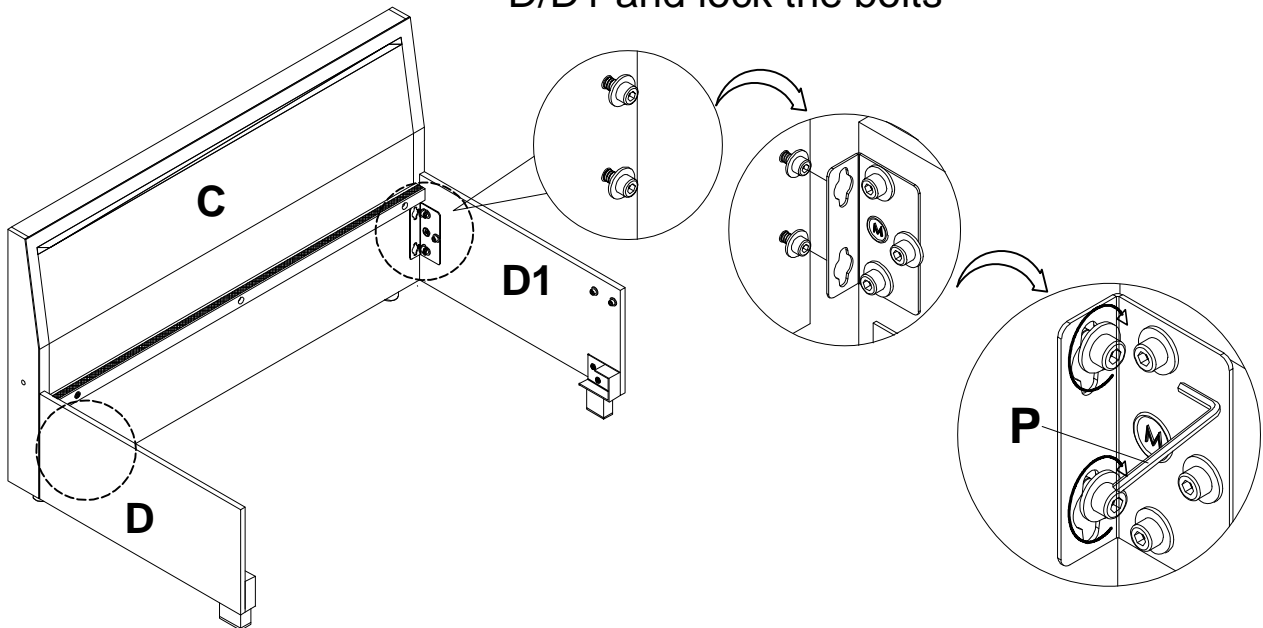

	P x 1PC
---	---------

## STEP 13

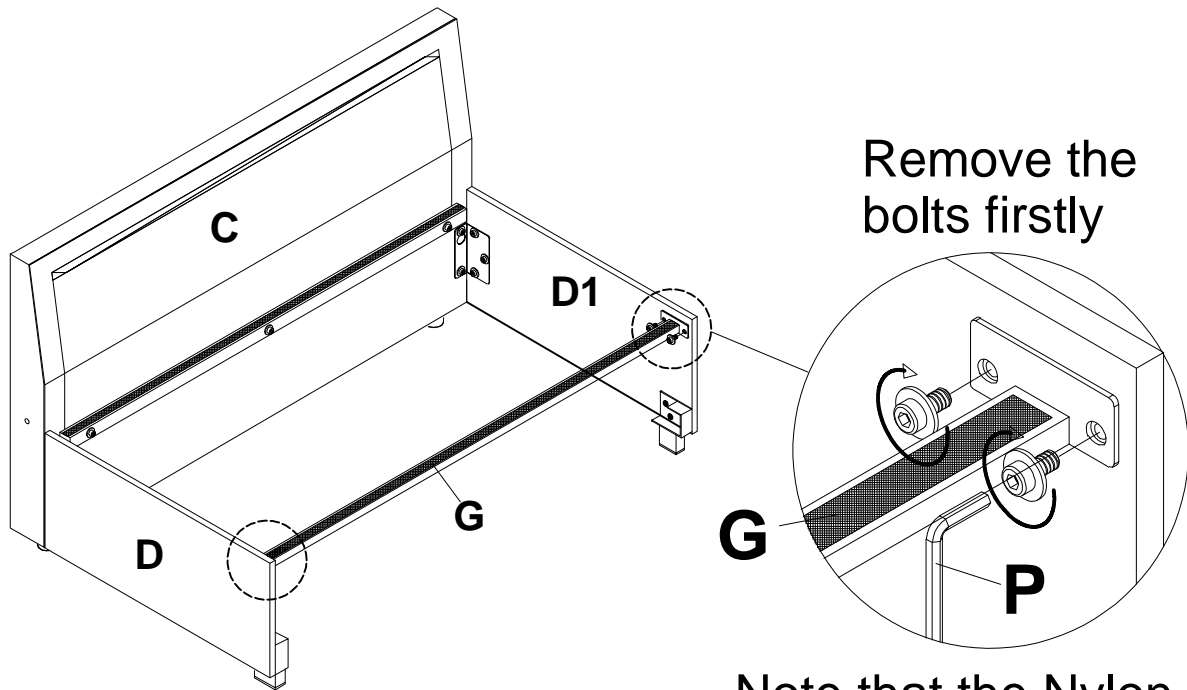

Note that the Nylon Fastener is facing upwards

## STEP 14

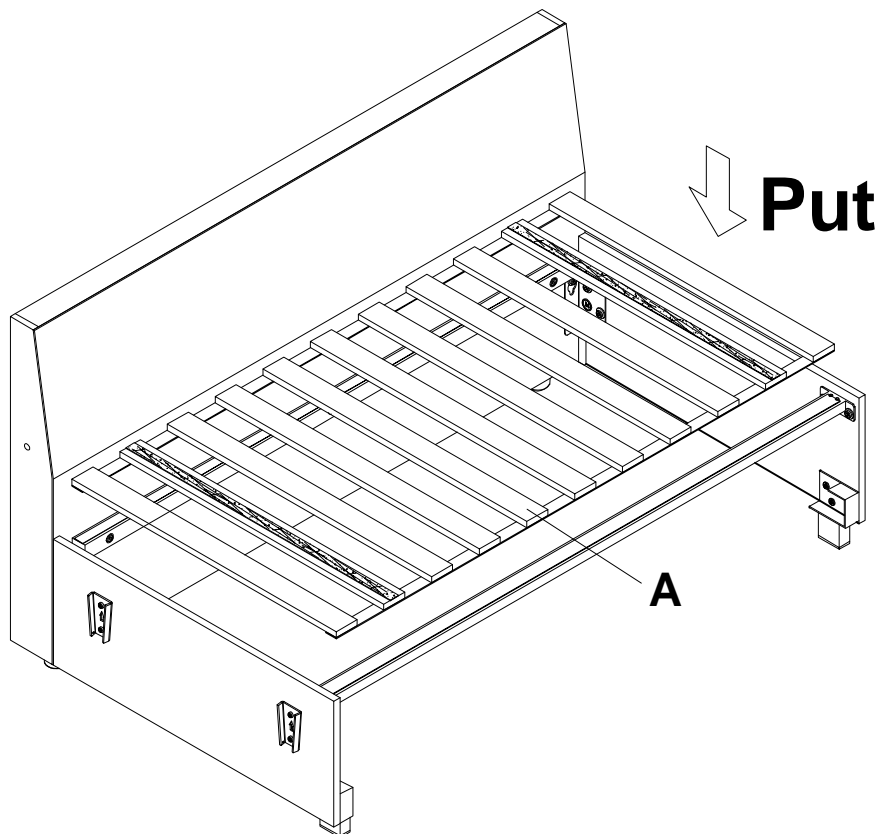

Main Structure Accessories

CHAISE

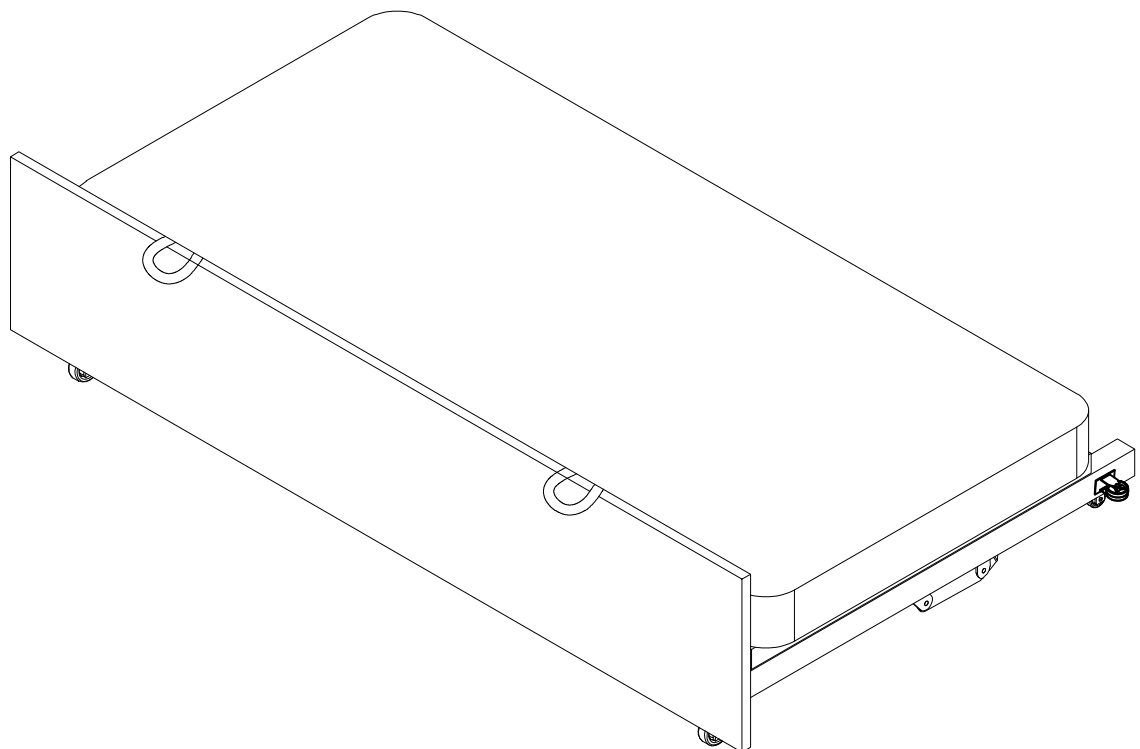
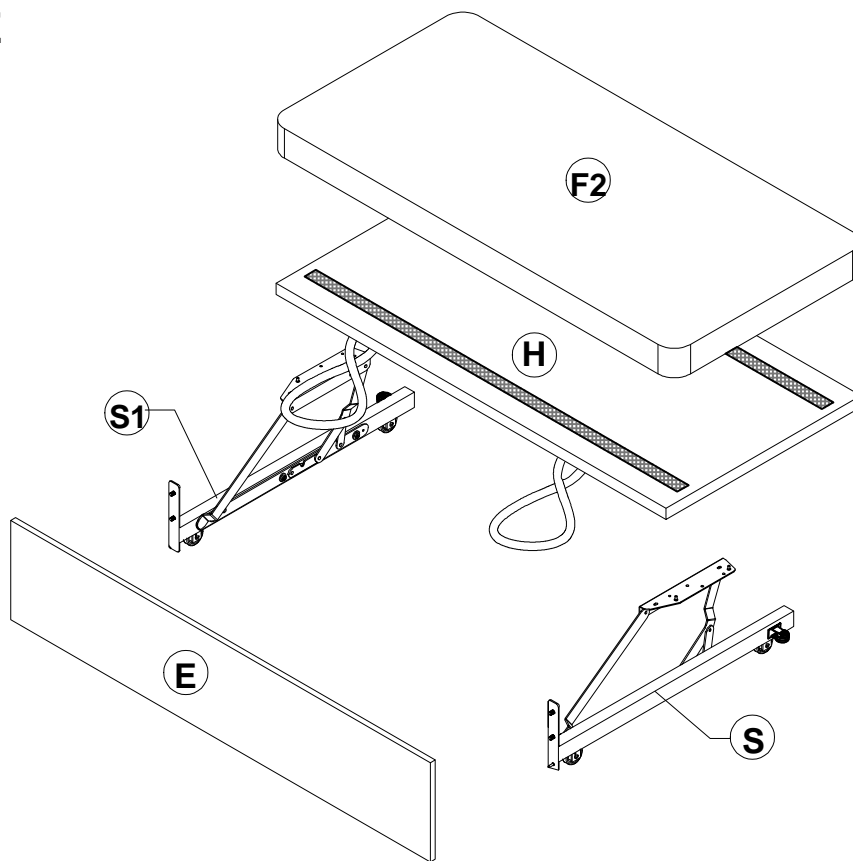

## STEP 15

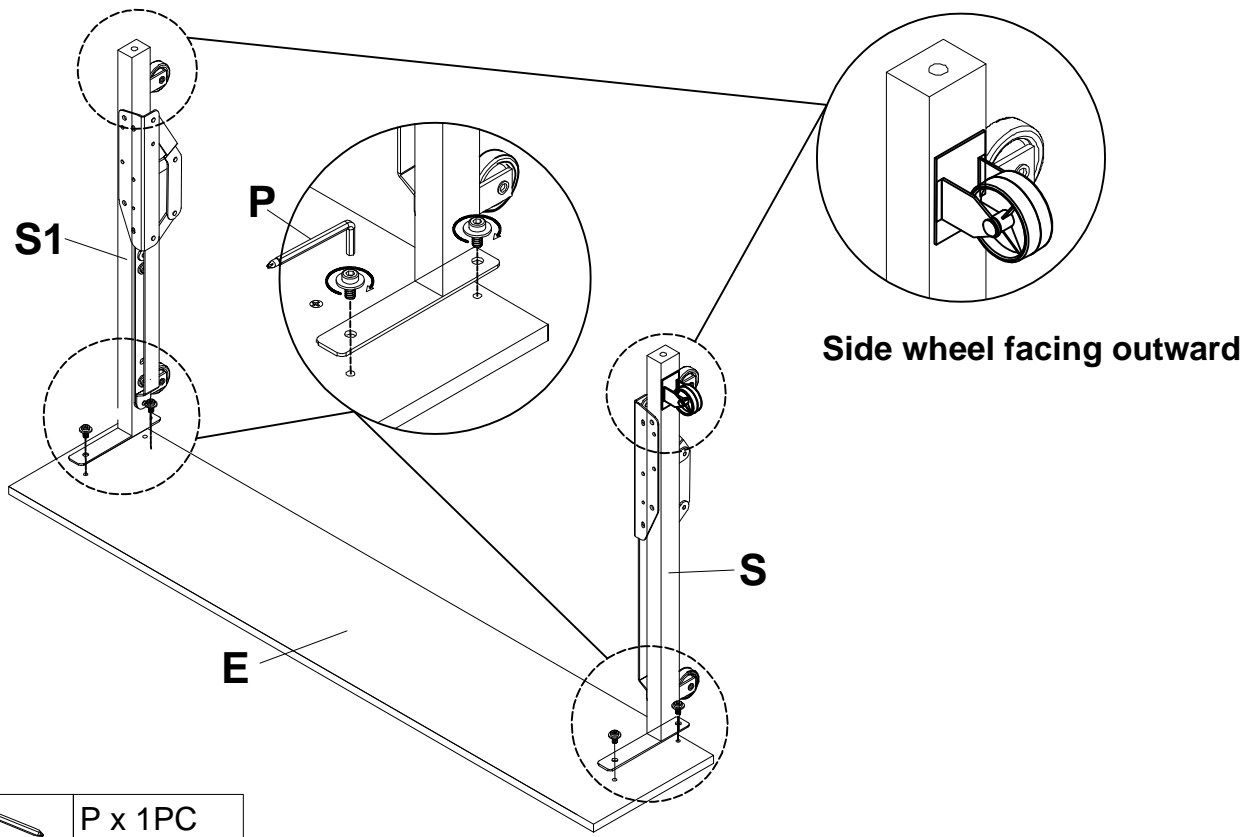

## STEP 16

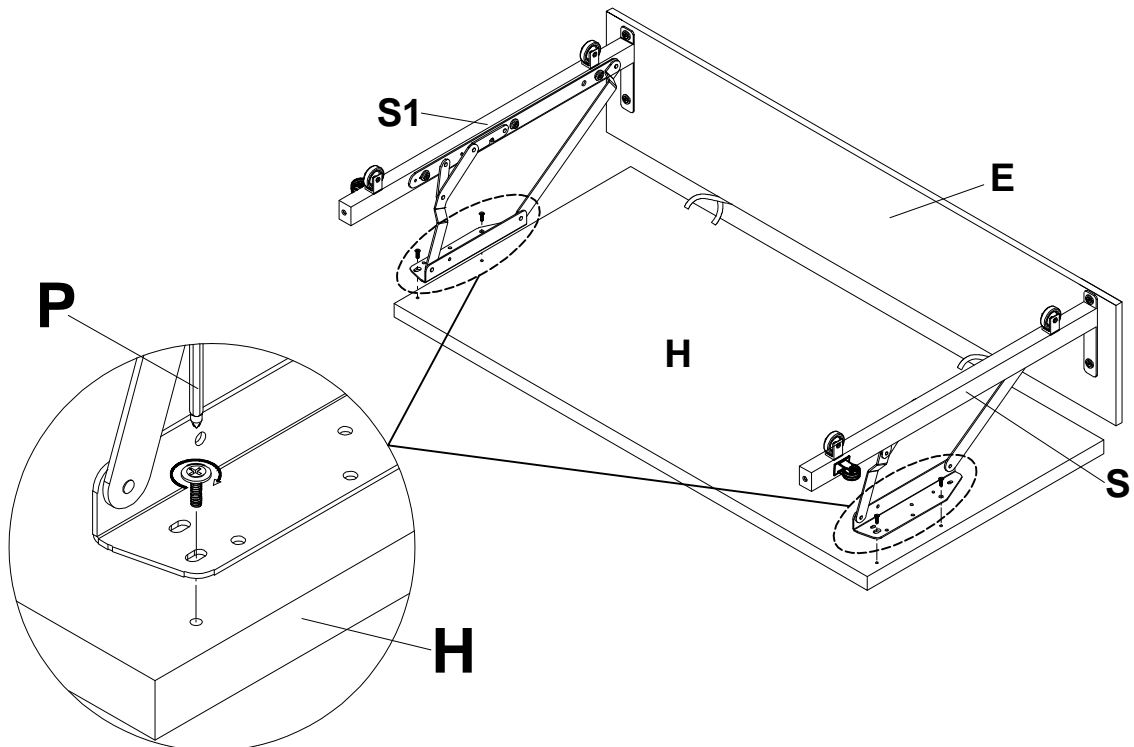

First loosen the bolts, instal  
S/S1 and lock the bolts

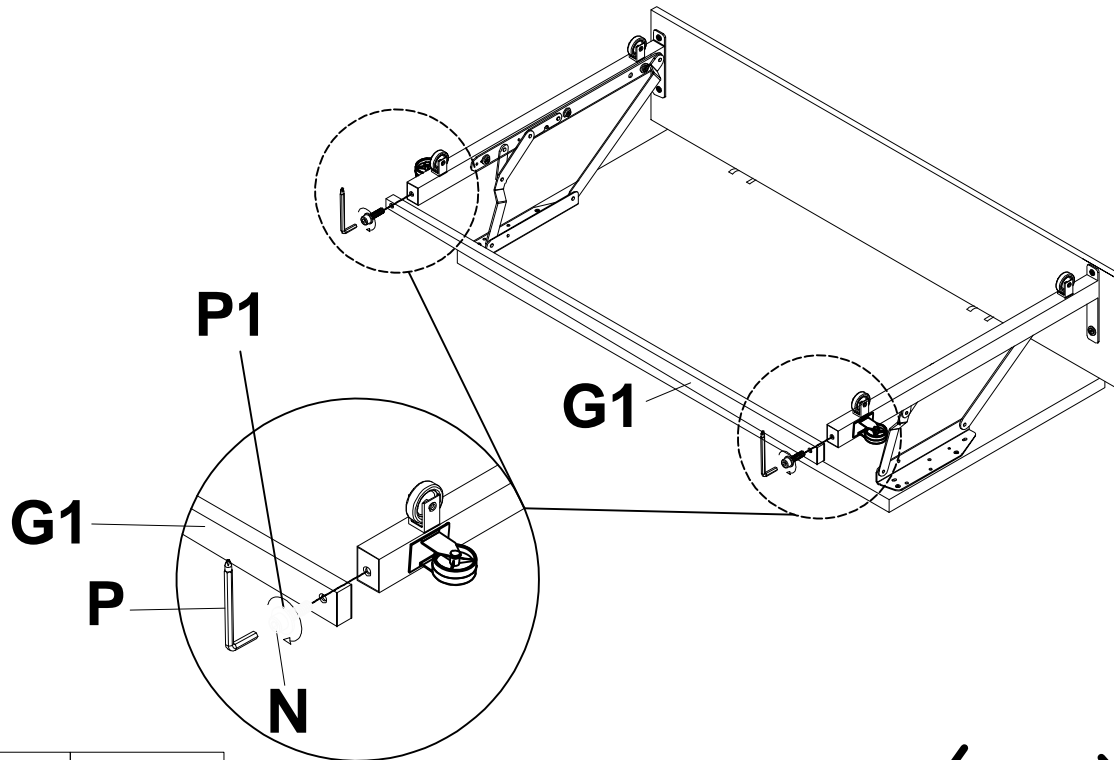

# Assembly Steps(EN) / Montageschritte(DE)

## STEP 17



	N x 2PCS
	P1 x 2PCS
	P x 1PC

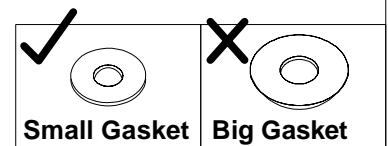

## STEP 18

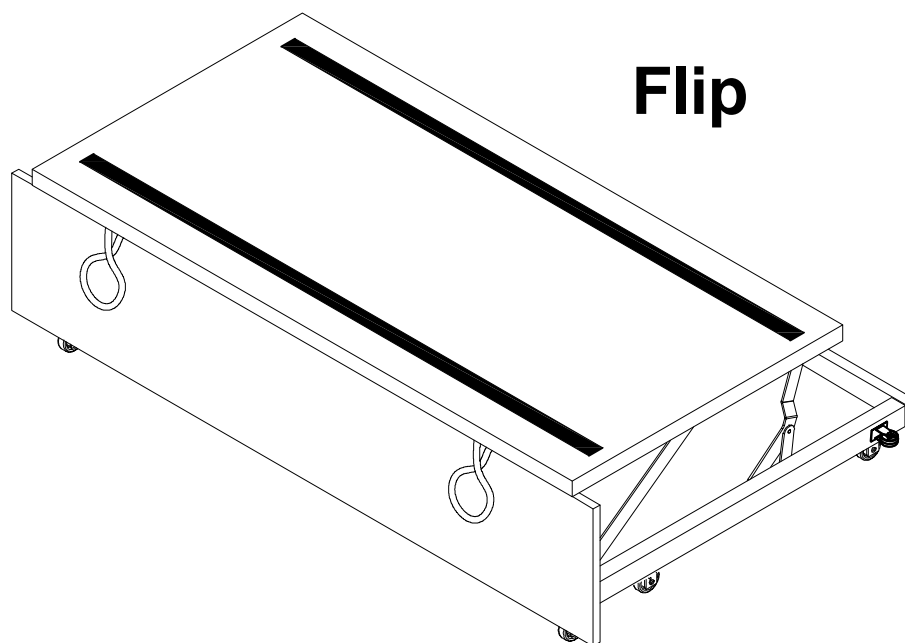

**STEP 19**

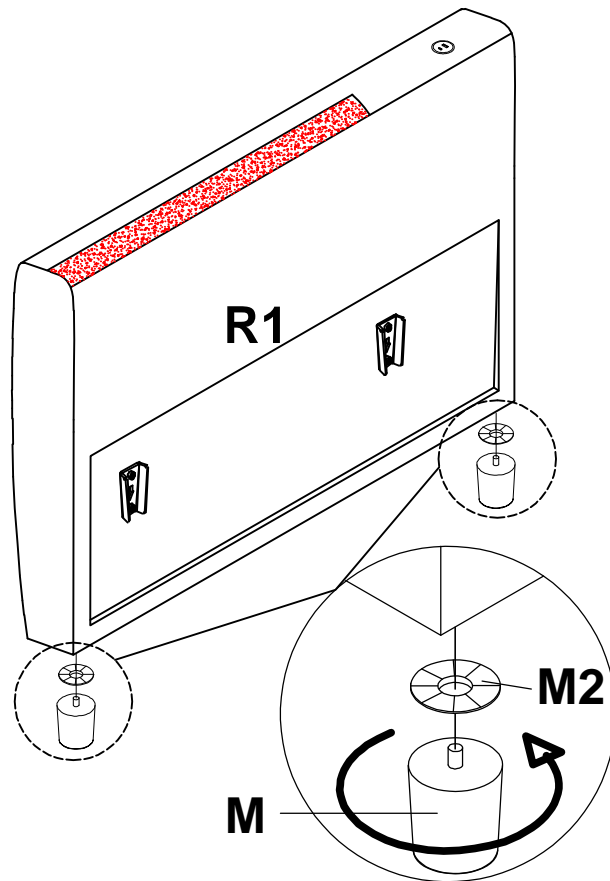

**STEP 20**

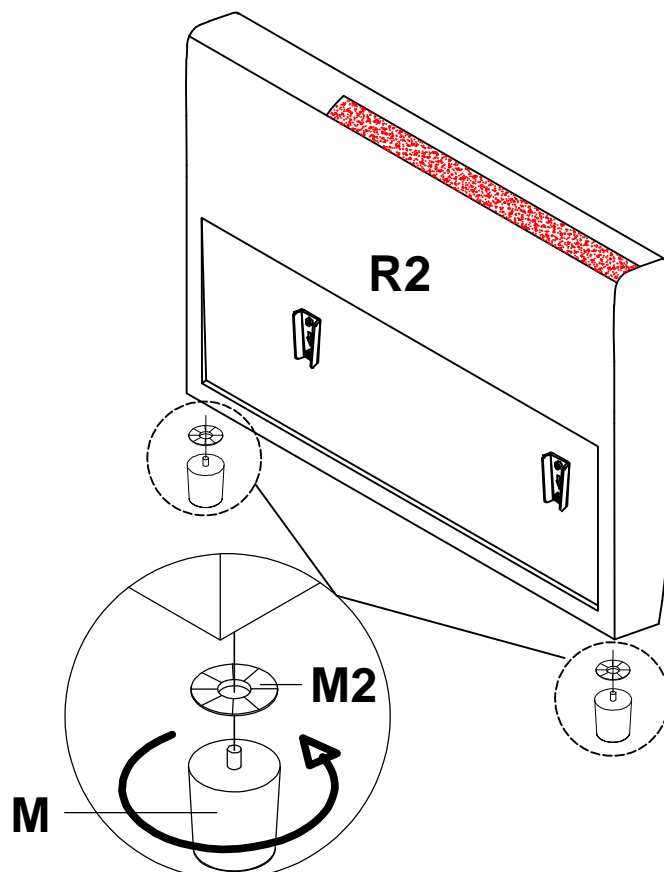

## STEP 21

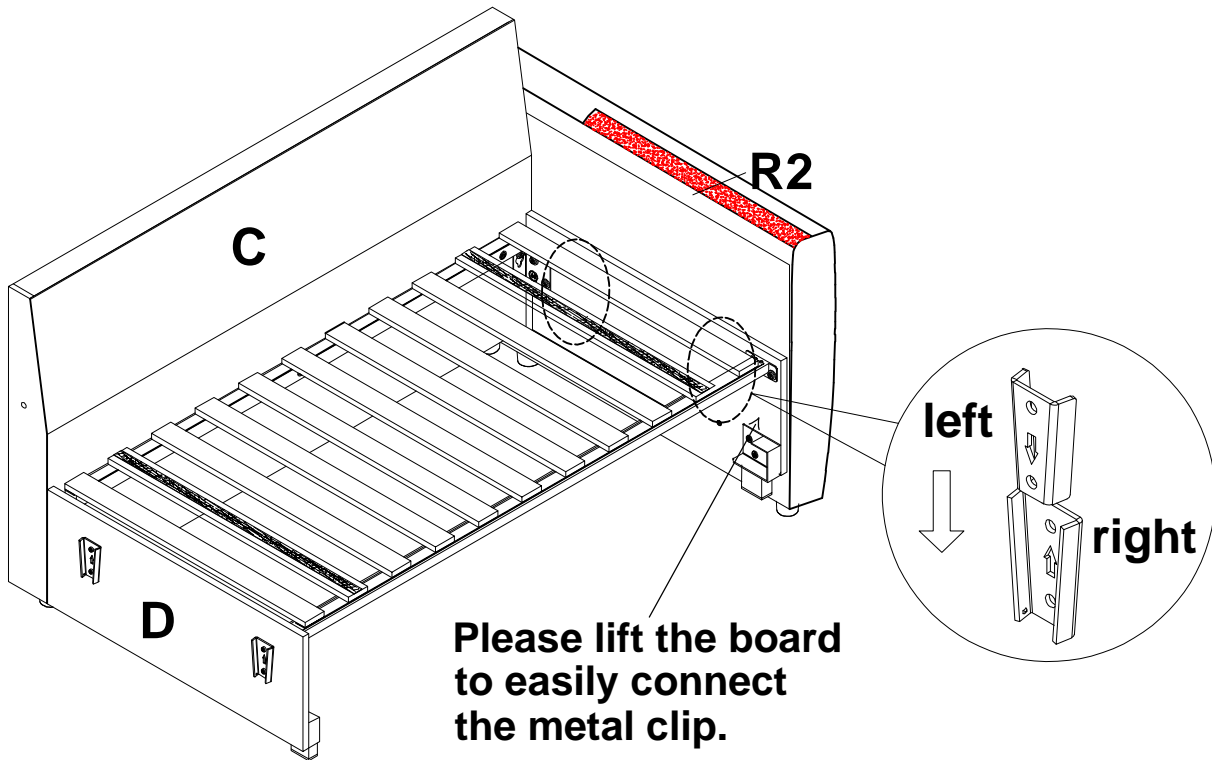

## STEP 22

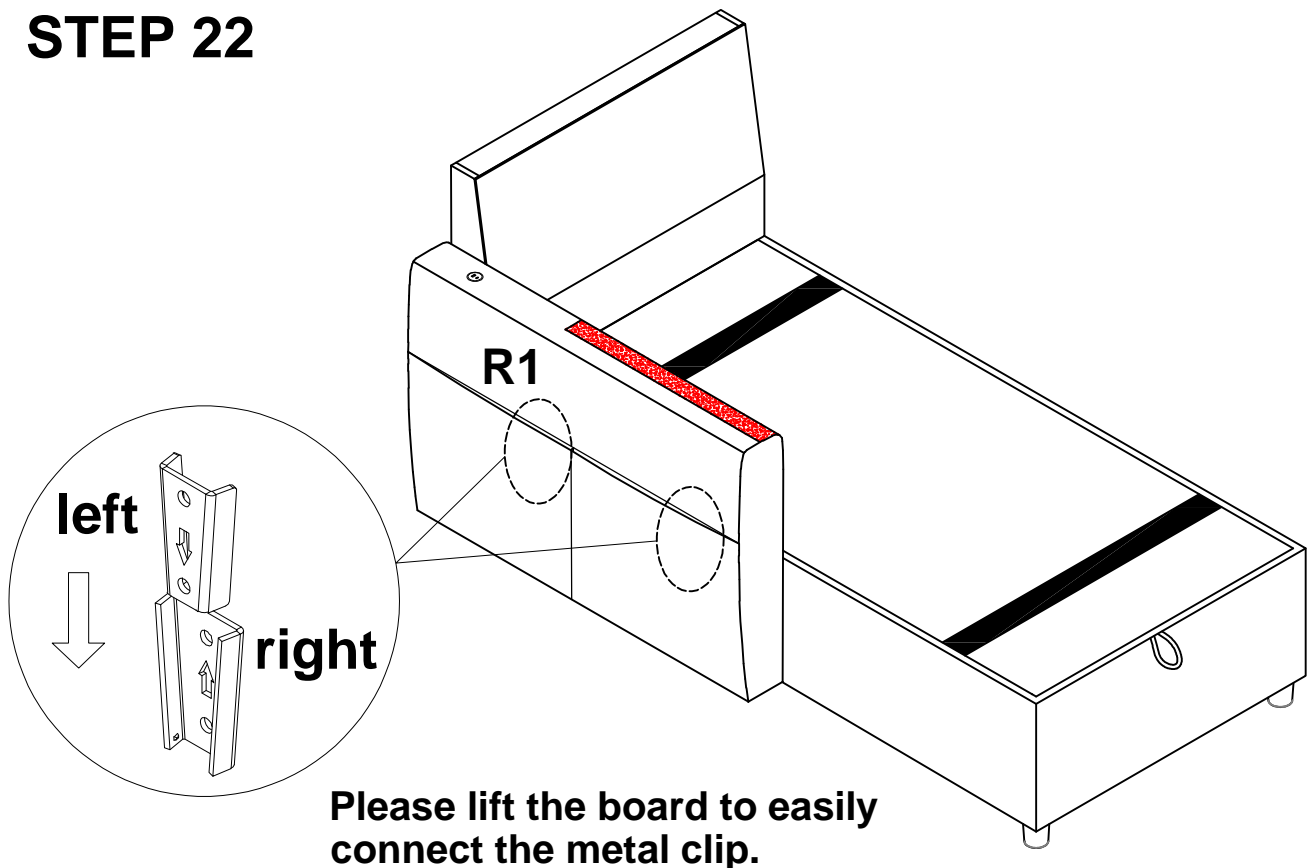

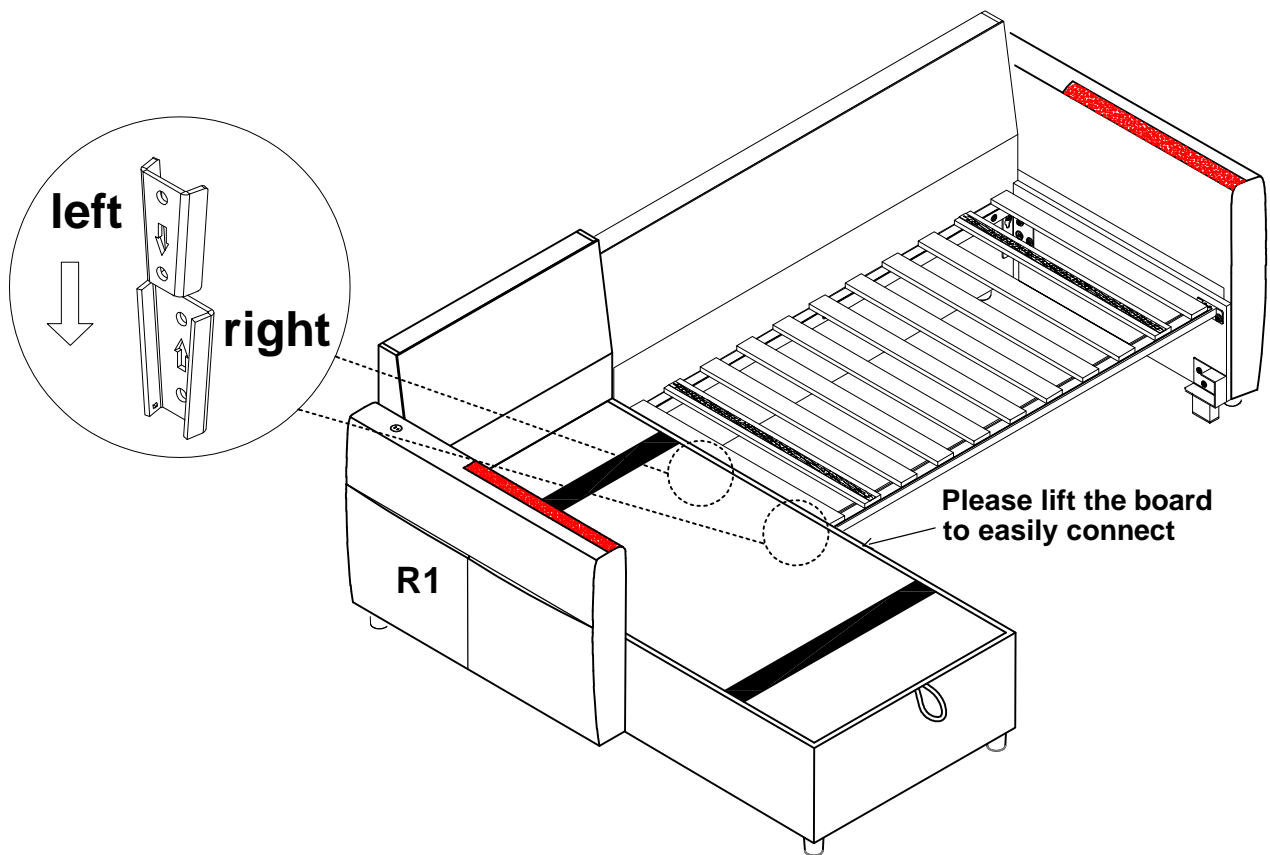

## STEP 23

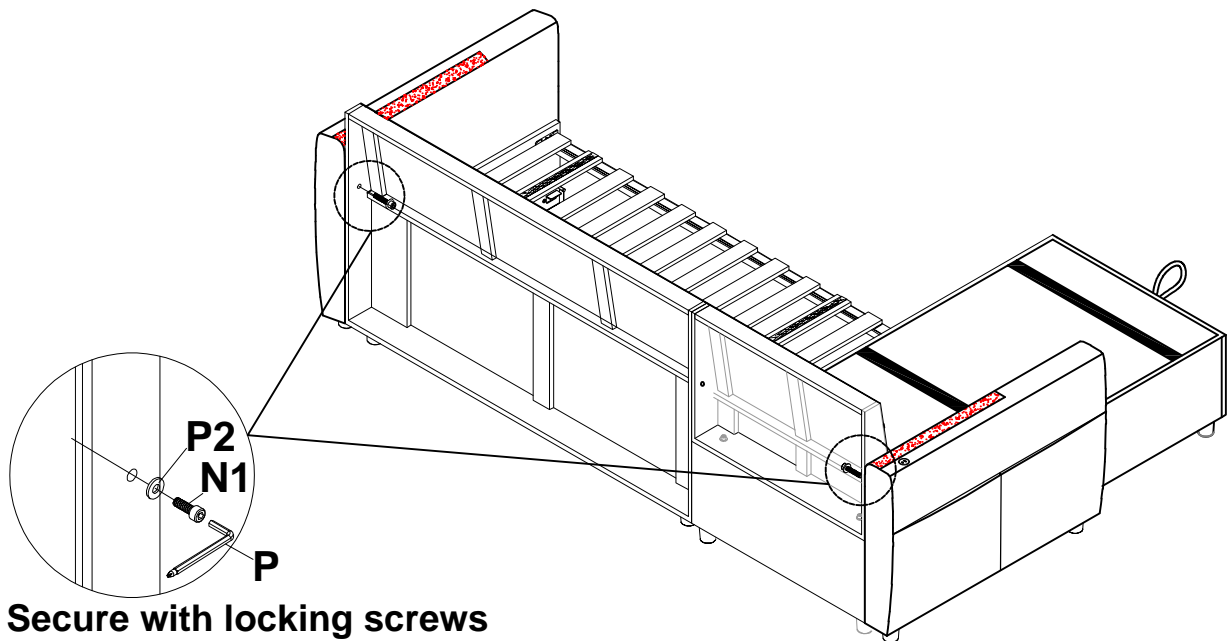

## STEP 24



	N1x 2PCS
	P2 x 2PCS
	P x 1PC

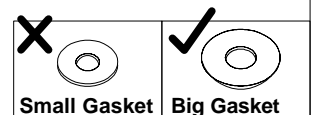

# Assembly Steps(EN) / Montageschritte(DE)

## STEP 25

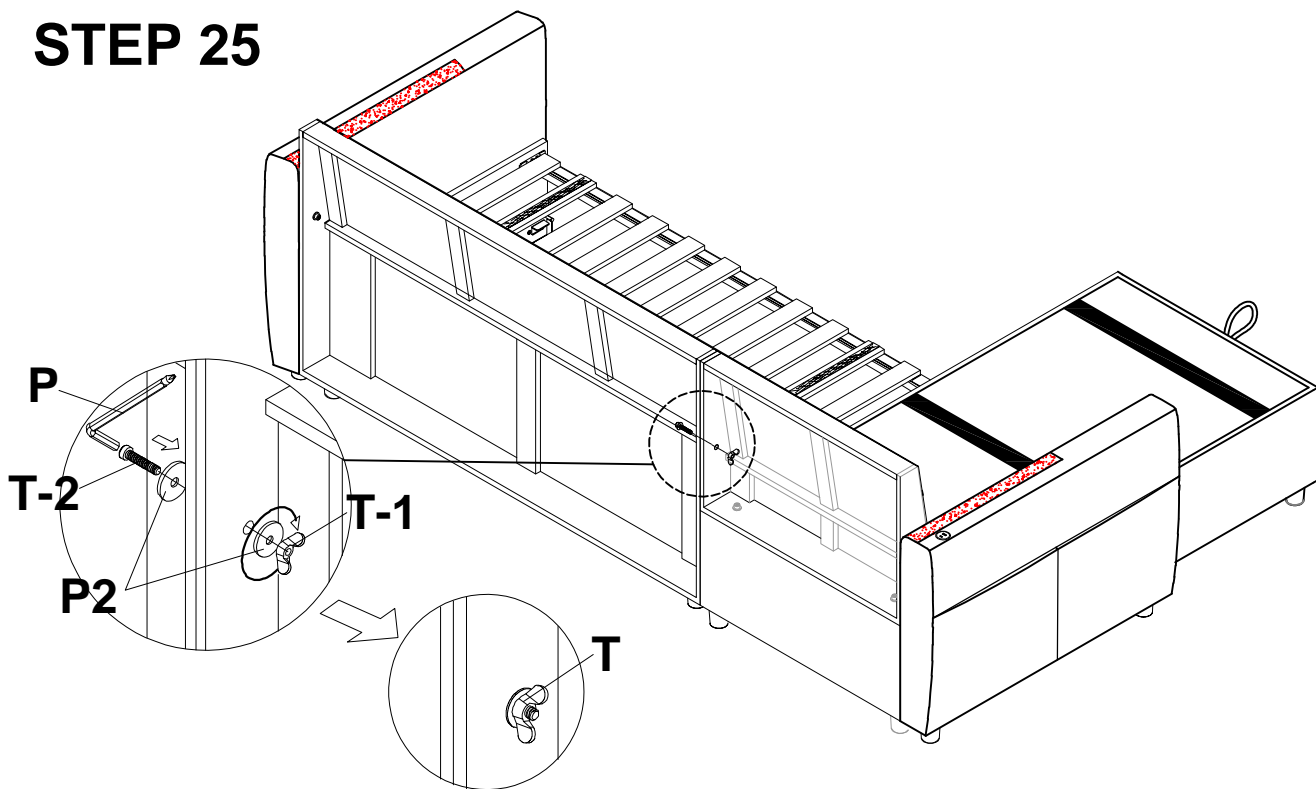

Screw through hole and tighten with butterfly nut.

	T x 1PC
	P2 x 2PCS
	P x 1PC

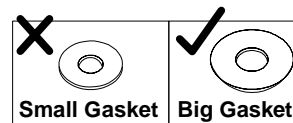

## STEP 26

Lift it slightly and place it on the track.

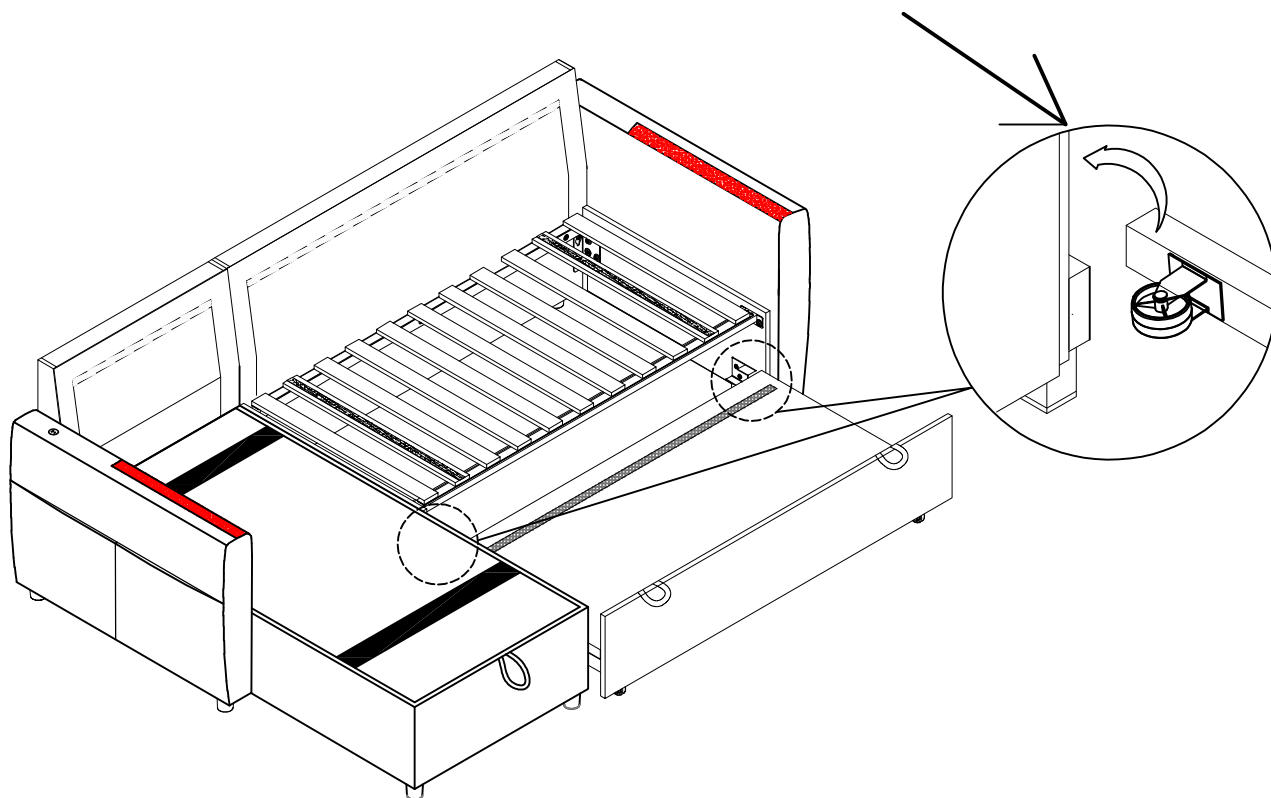

## STEP 27

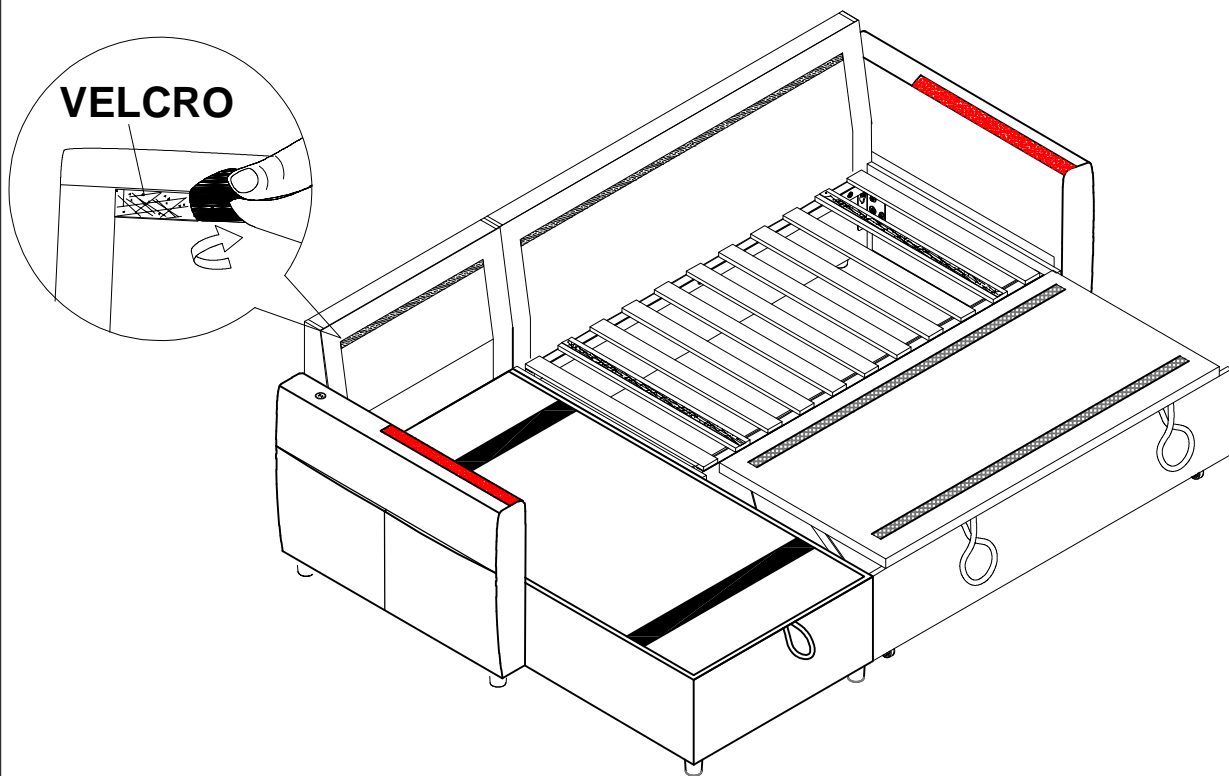

## STEP 28

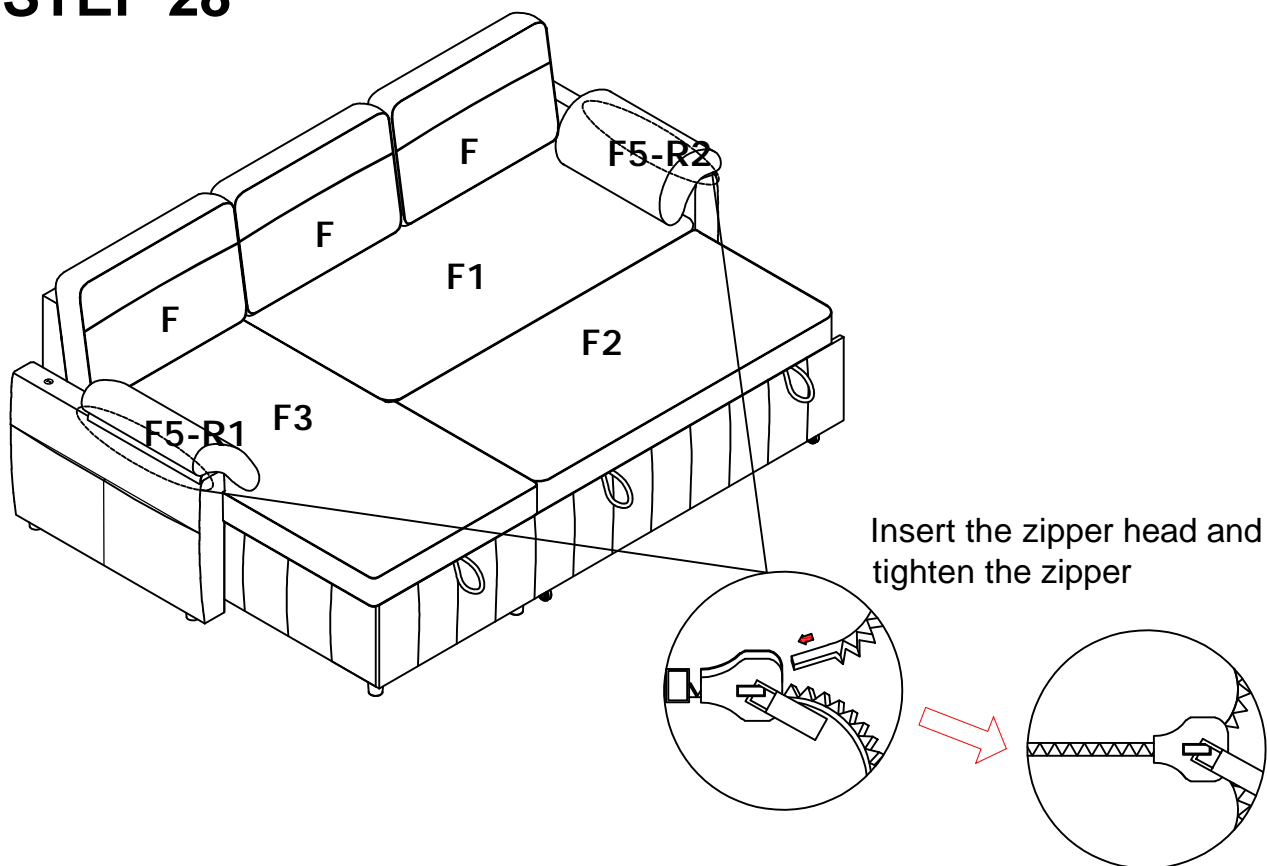

**Assembly Steps(EN) / Montageschritte(DE)**

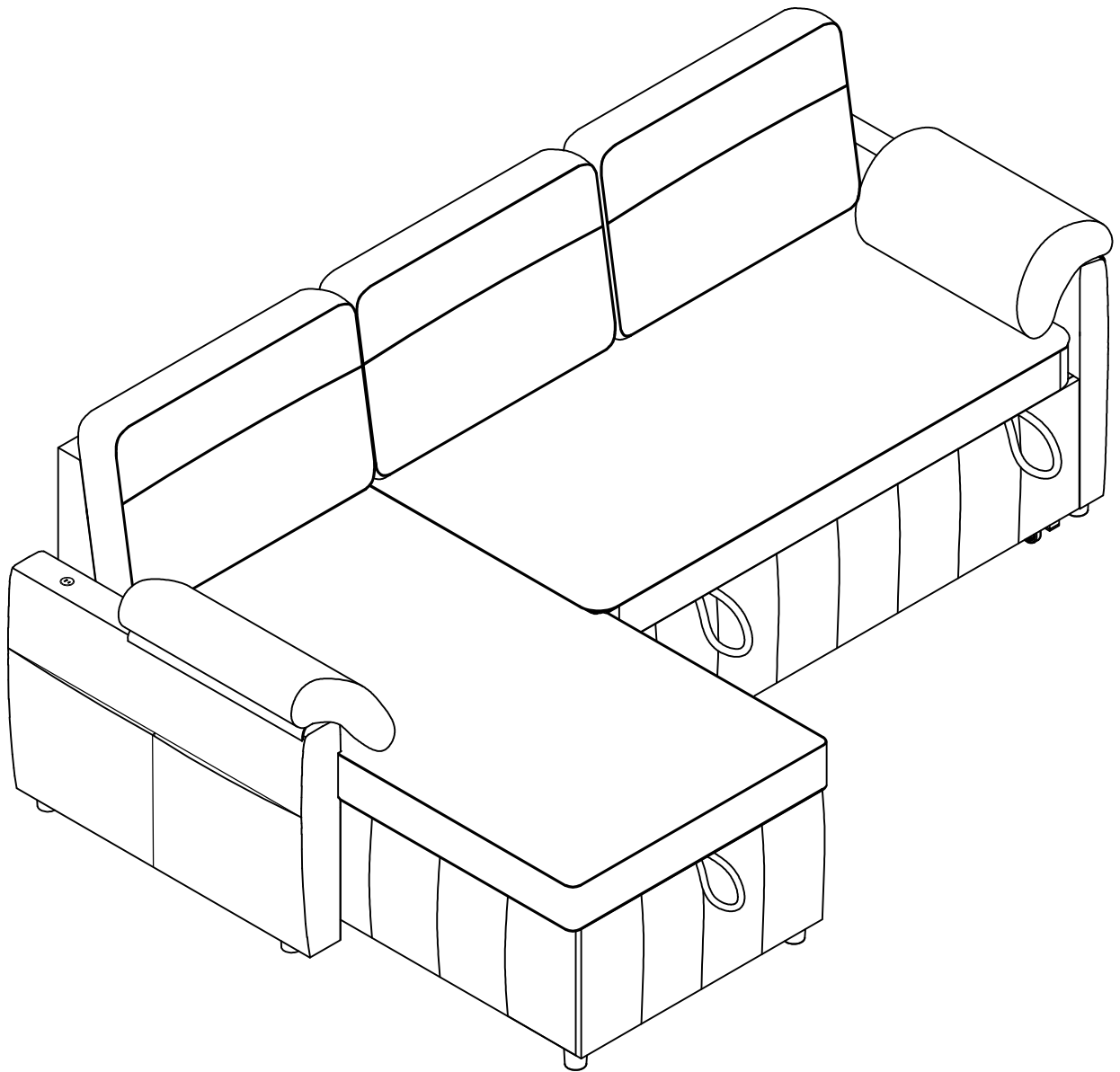

## Assembly Option ②

### STEP 29

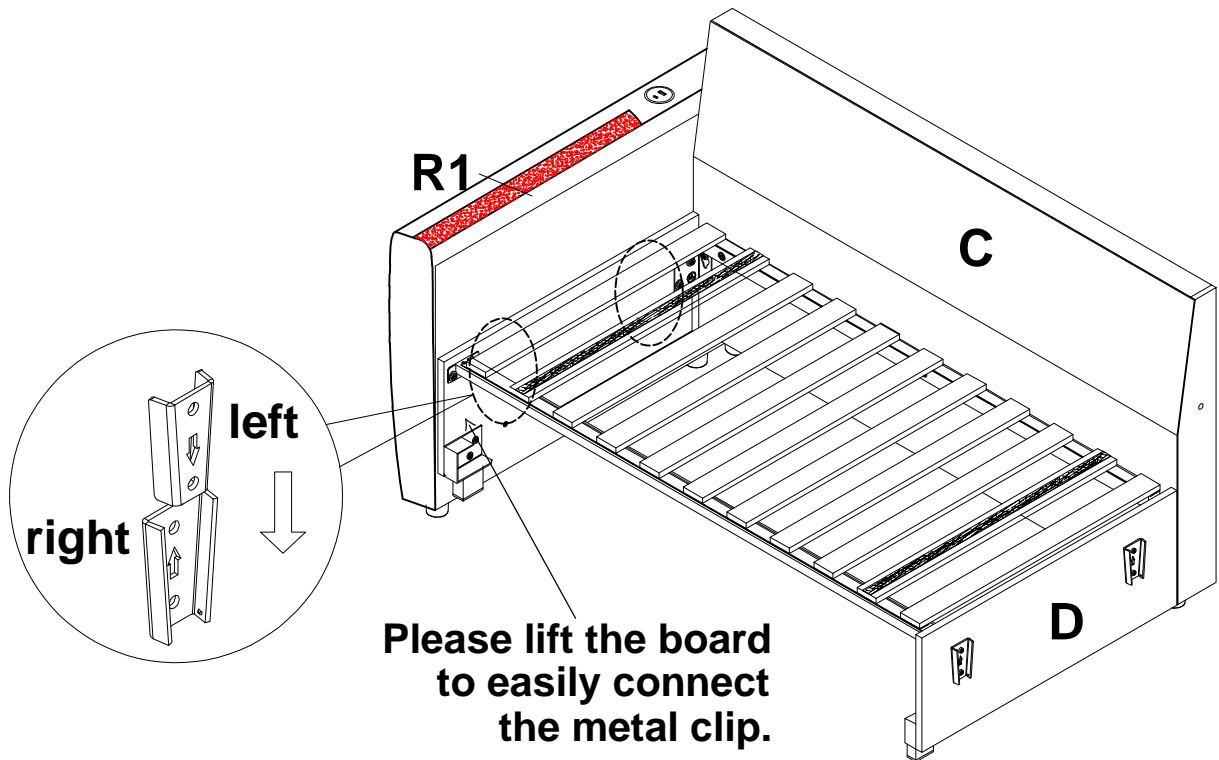

## Assembly Option ②

### STEP 30

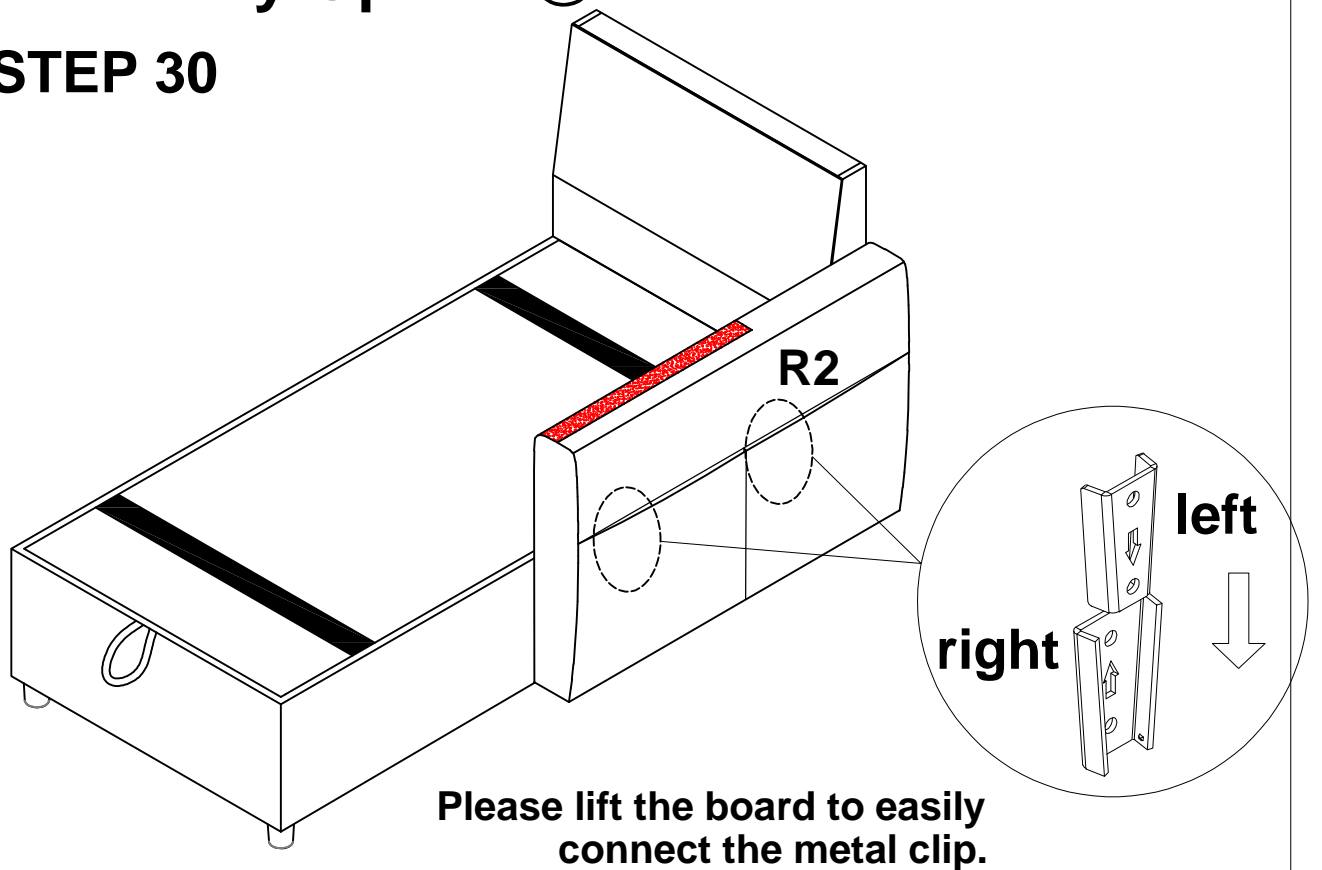

## Assembly Option ②

### STEP 31

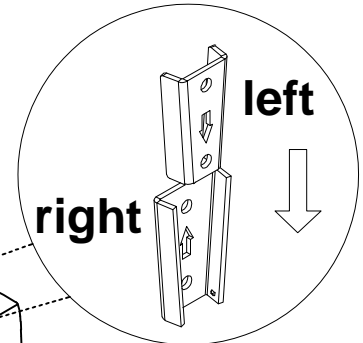
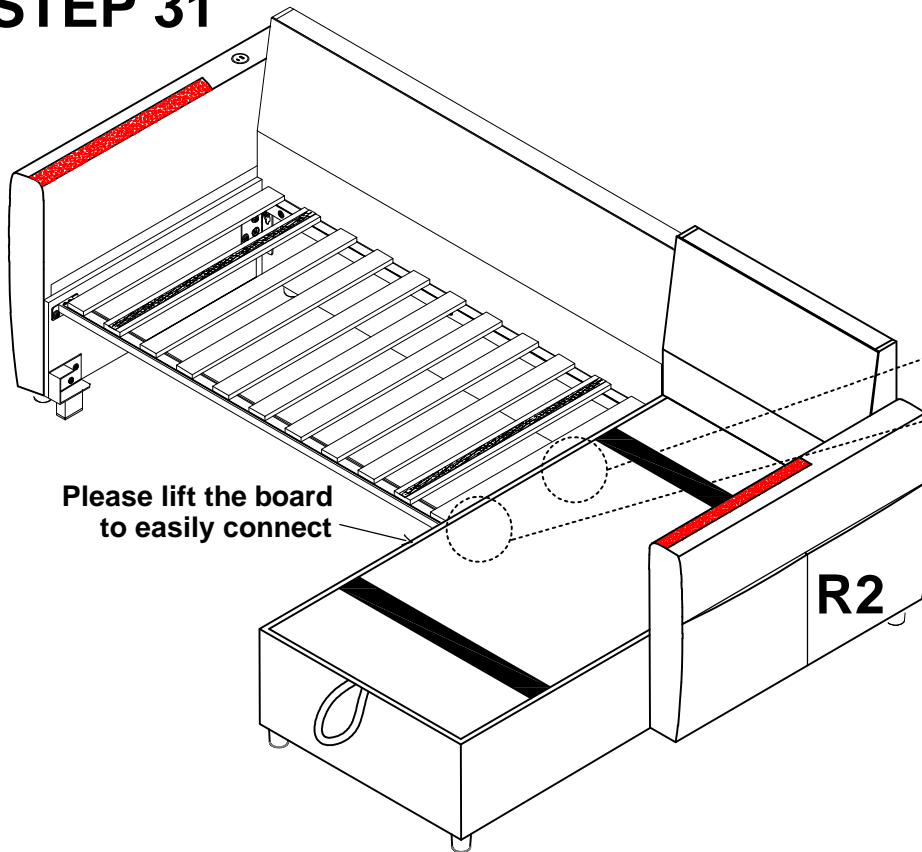

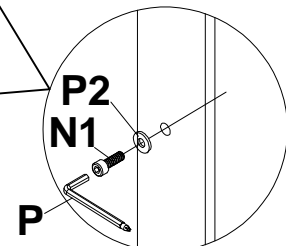
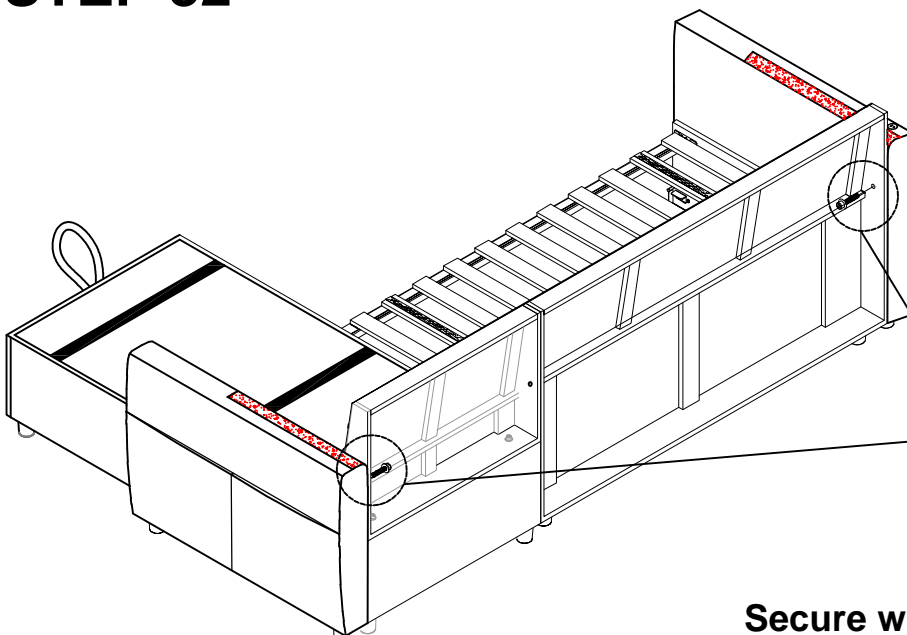

## Assembly Option ②

### STEP 32



Secure with locking screws

	N1x 2PCS
	P2 x 2PCS
	P x 1PC

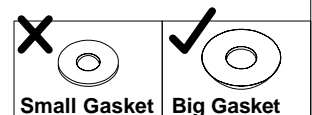

## Assembly Option ②

### STEP 33

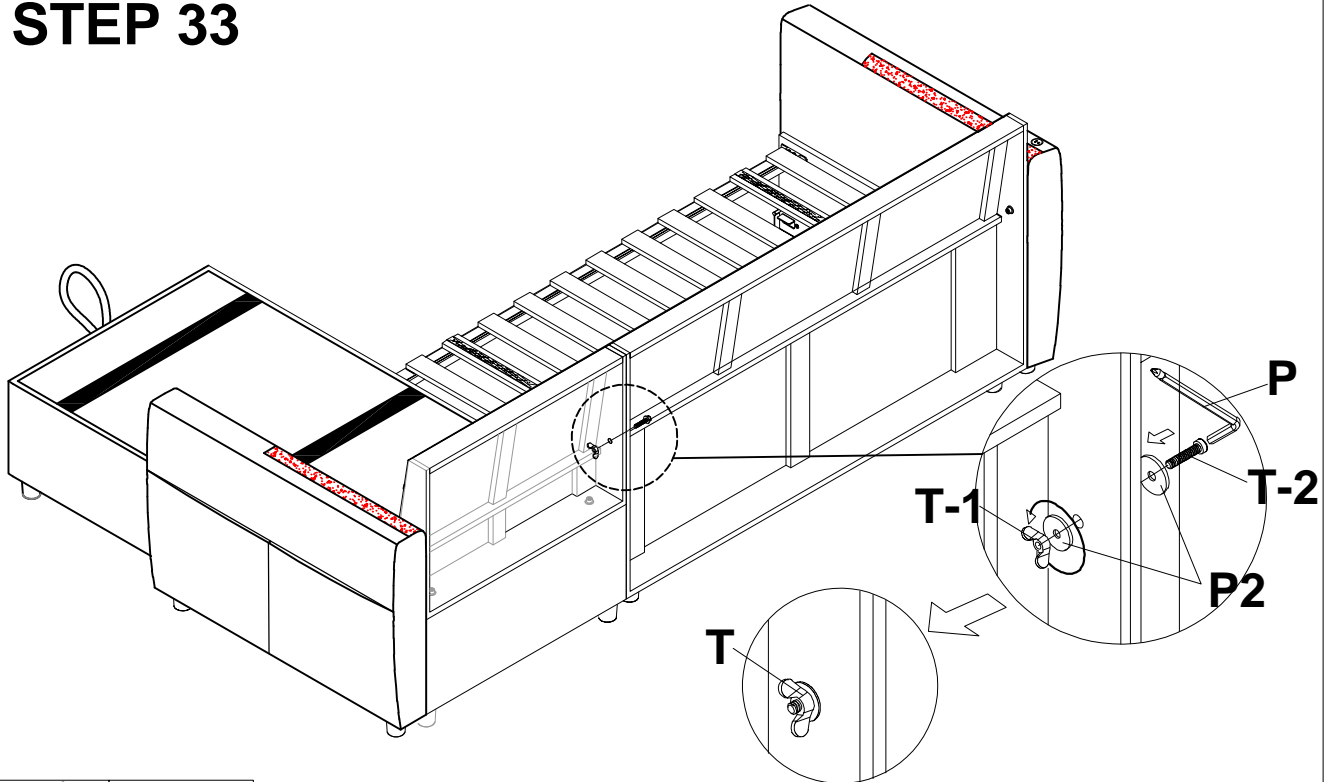

	T x 1PC
	P2 x 2PCS
	P x 1PC

Screw through hole and tighten with butterfly nut.

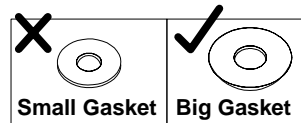

## Assembly Option ②

### STEP 34

Lift it slightly and place it on the track.

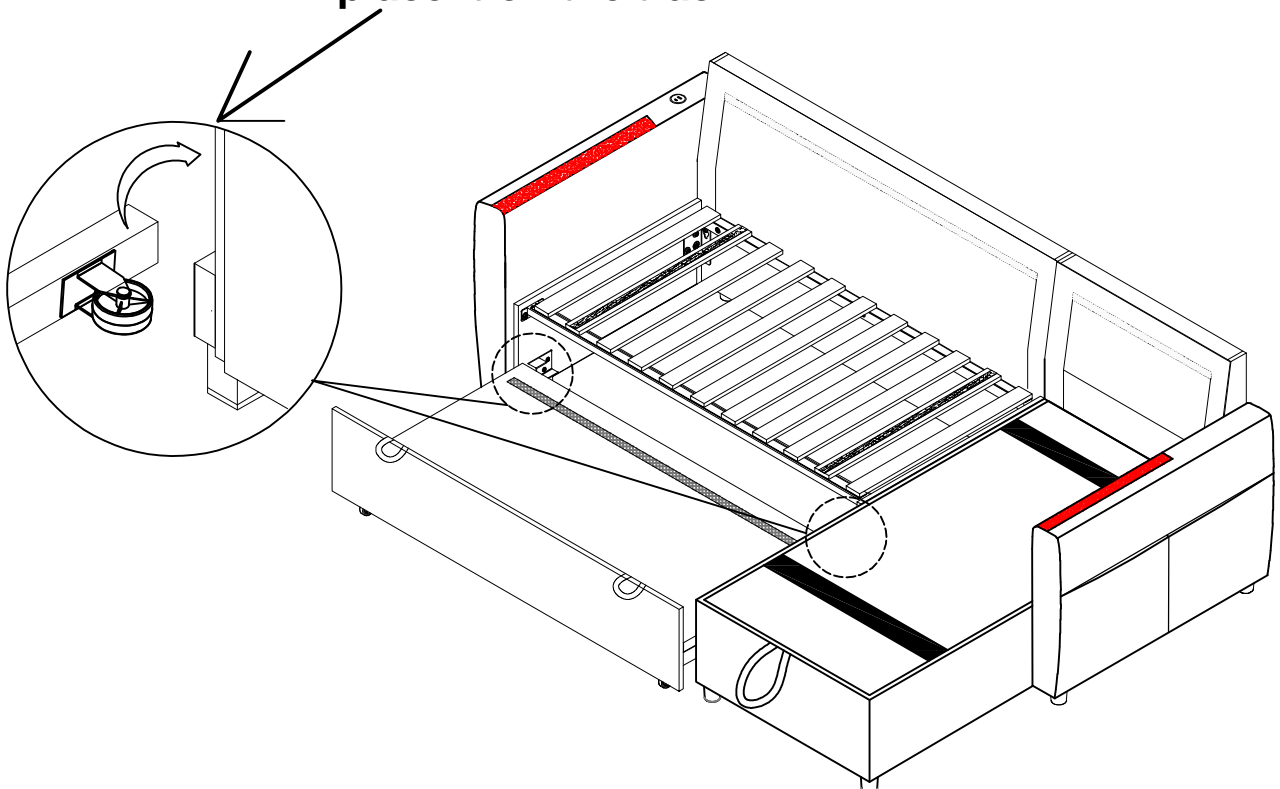

## Assembly Option ②

### STEP 35

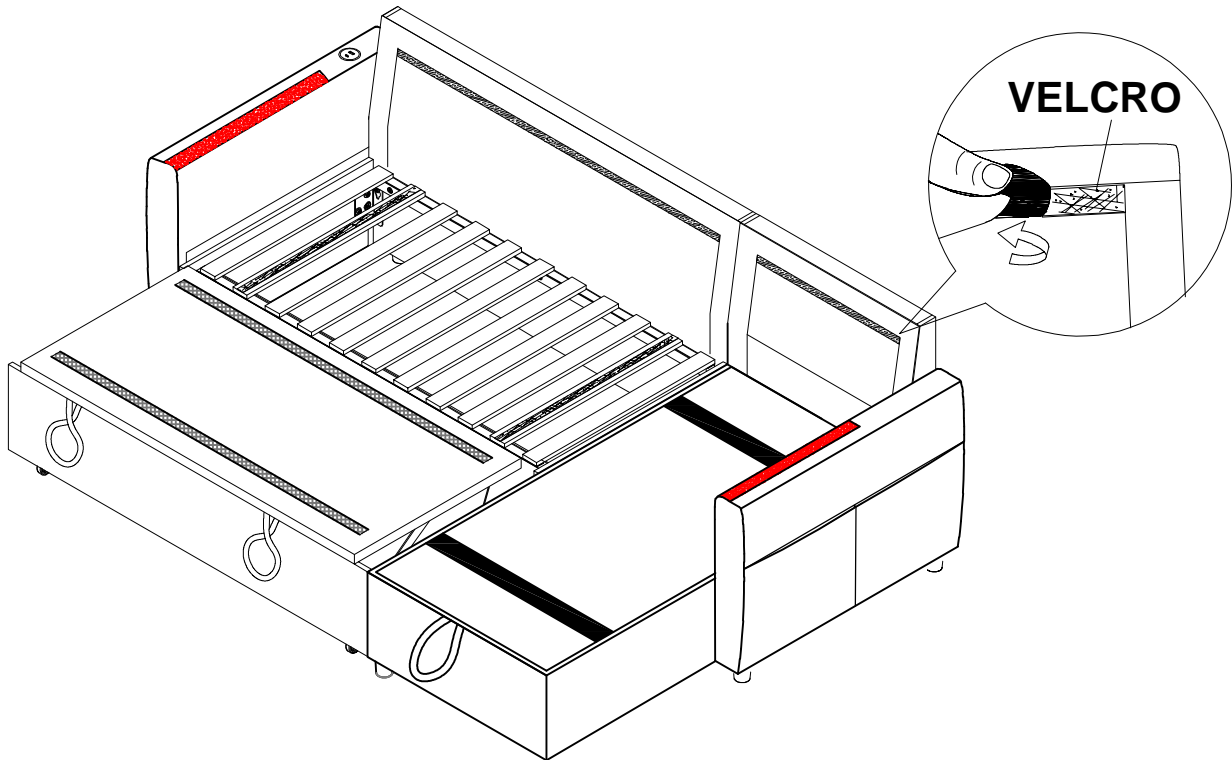

## Assembly Option ②

### STEP 36

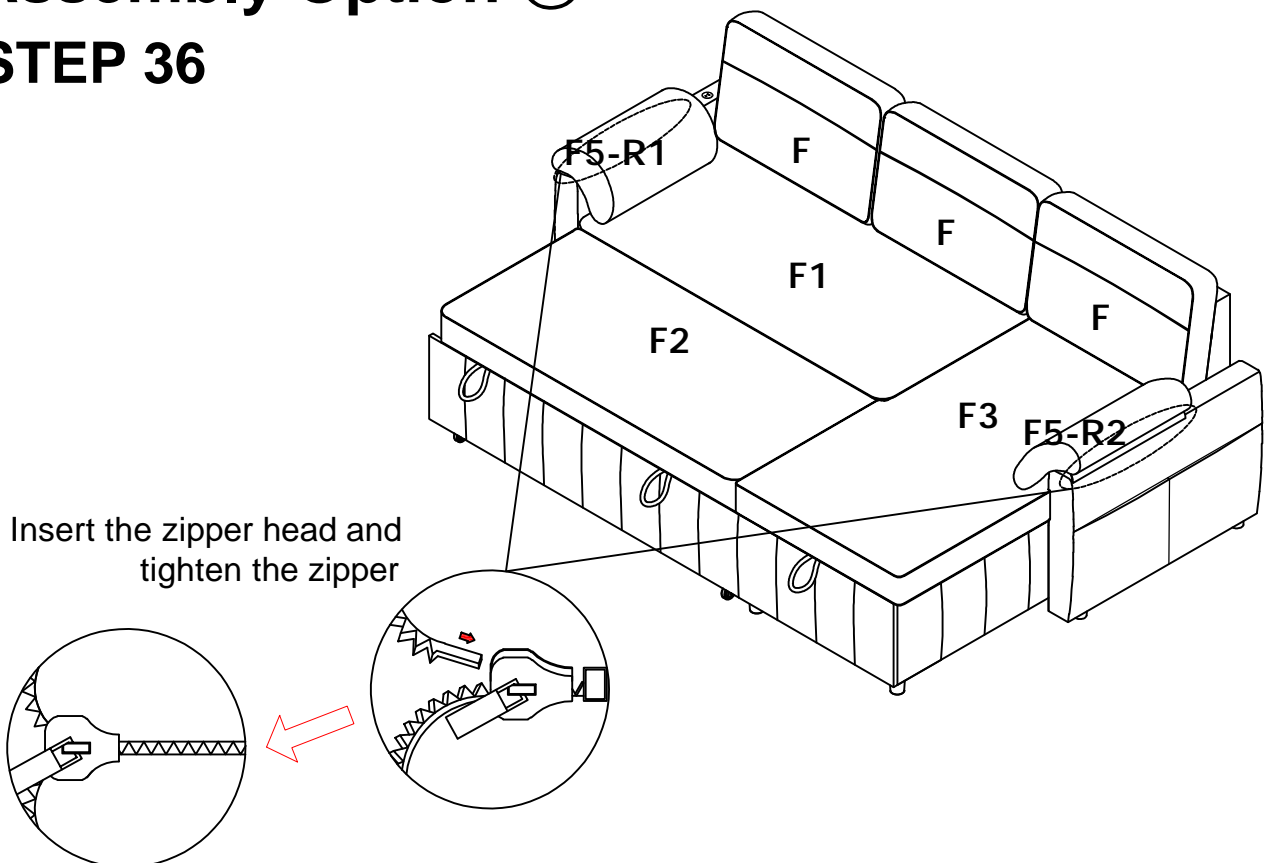

# Assembly Option ②

