

Storage Shed Owner Manual & Assemble Guide

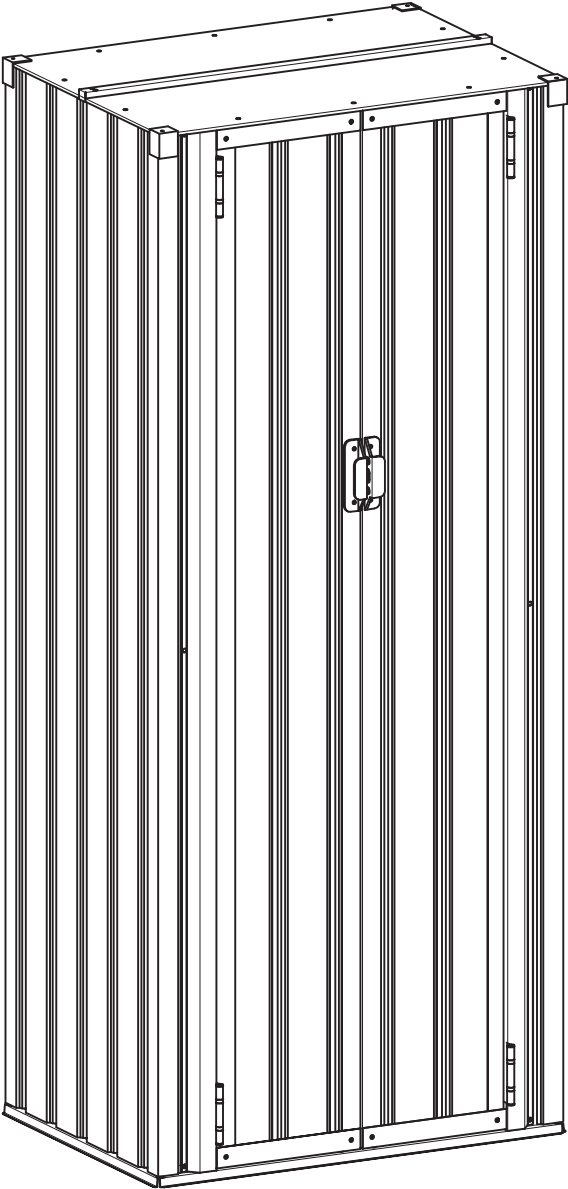

Customer Service:



If you have any problem, please contact us through the online platform.

Shed Size

Shed Overall Size:29.6”(L) x 21.4”(W) x 69.8”(H)

All parts are packed in a box, please note that refer to the parts list to check if all parts are received.

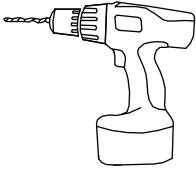
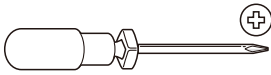
Please prepare below tools before installation. (Not Included)

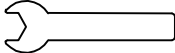
 Electric Screwdriver	 + Manual Screwdriver	 Ladder
Package included Tools	 Gloves x 1Pair	 Spanner x 1

ATTENTION

Care **MUST** be taken when handling various pieces of your building since many contain sharp edges.

Do NOT attempt to assemble your building before double checking that you have all parts indicated in the parts lists. Any building left partially assembled may be seriously damaged by even light winds.

Do NOT attempt to assemble your building on a windy day, the large panels can catch the wind like a “sail”, making construction difficult and unsafe. **Watch the weather closely.** Keep children and pets away from the worksite during construction and until the building is completely assembled. This will help avoid distractions and any accidents which may occur. Never concentrate your weight on the roof of the building.

Before assembling any parts, your base should be constructed and an anchoring system should be ready to use. Your building must be anchored to prevent wind damage.

ASSEMBLY

The best location is a level area with good drainage.

Allow enough space outside the building to be able to access the roof with a ladder.

USE TEAMWORK: Two or more people are required to assemble your building.

CARE & MAINTENANCE

Do NOT use power washing to clean your shed.

















Combustibles and corrosives must be stored in air tight containers designed for chemical and/or combustible storage.















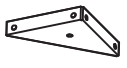

Rust Protection Precautions

Avoid nicking or scraping the coating surface, inside and out.

PLEASE KEEP THIS INSTRUCTION FOR FUTURE REFERENCE.

Part List

PART	NO.	QTY.
	C23-1	2
	C23-2	2
	C23-3	2
	C23-4	2
	C23-5	2
	C23-6	2
	C23-7	1
	C23-8	4
	C23-9	4
	C13	8
	C23-UA	2
	C23-DA	2
	C23-DLA	1
	C23-DRA	1
	C23-DDA	4
	C23-DBA	4

PART	NO.	QTY.
	W3-CB	4
	W3-B	3
	W3-B1	2
	W3-HC	2
	GC	4
	GB	2
	T-F	4
	F1	138
	F2	18
	F3	32
	F8	4
	V2	18
	C2	4
	DH	4
	CT	4
	M4	1
	ST	2

Part List

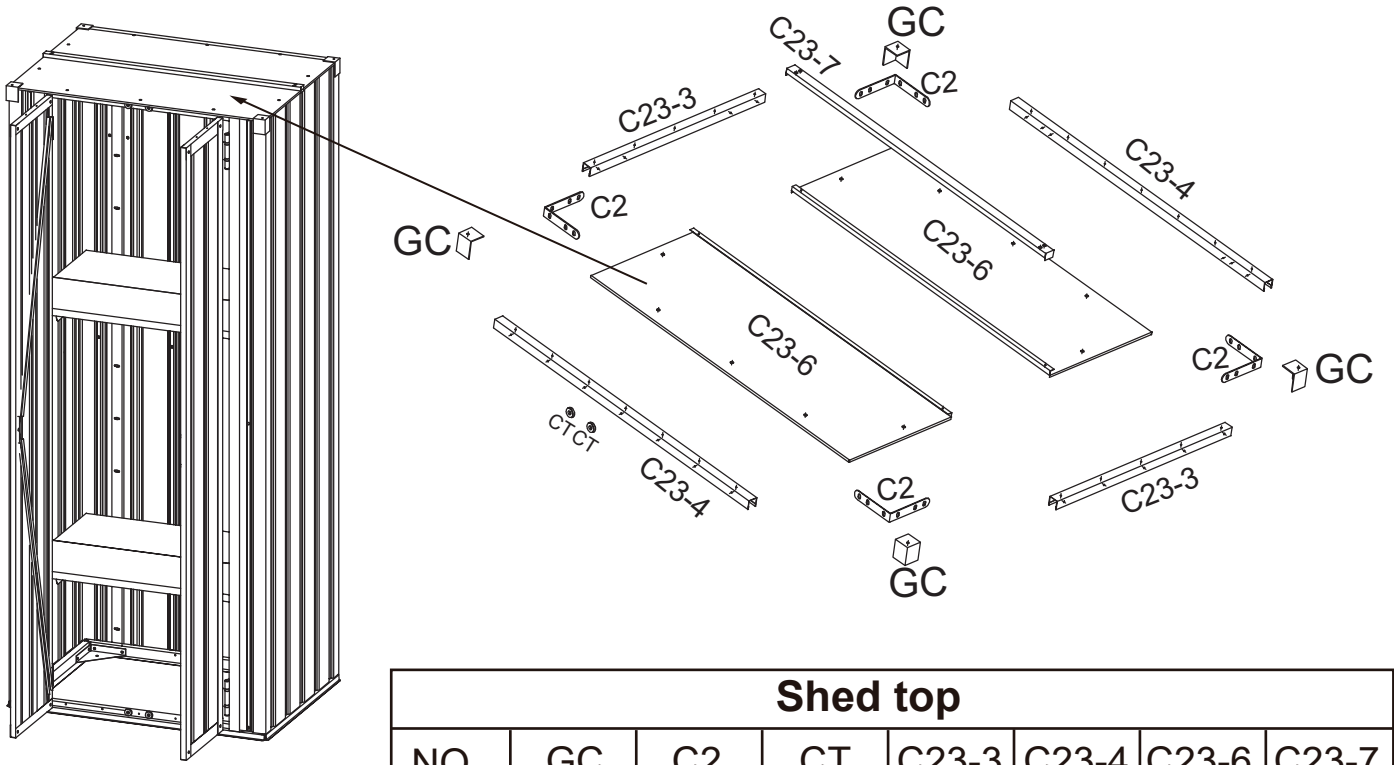

Shed top							
NO.	GC	C2	CT	C23-3	C23-4	C23-6	C23-7
QTY.	4	4	2	2	2	2	1

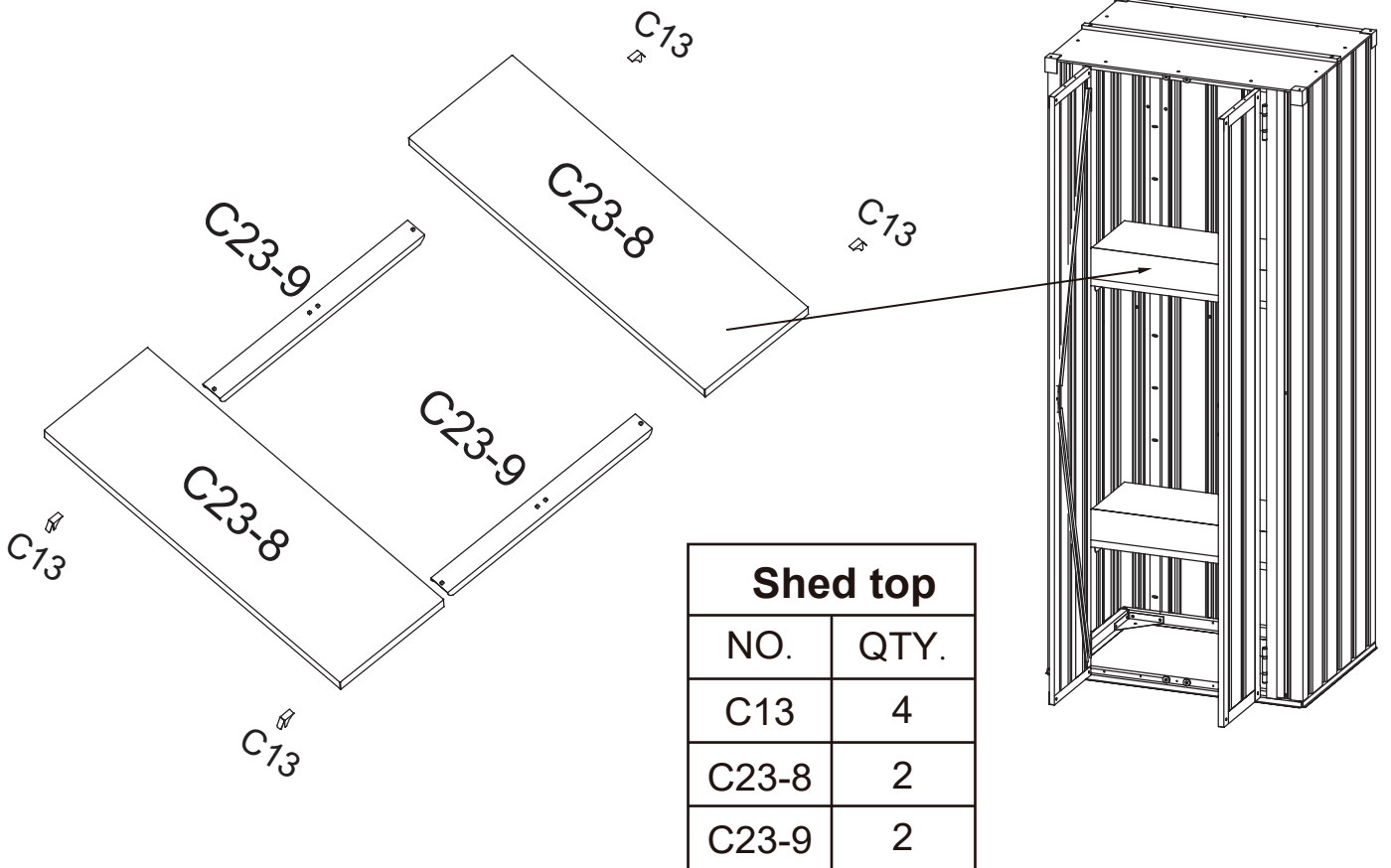

Shed top	
NO.	QTY.
C13	4
C23-8	2
C23-9	2



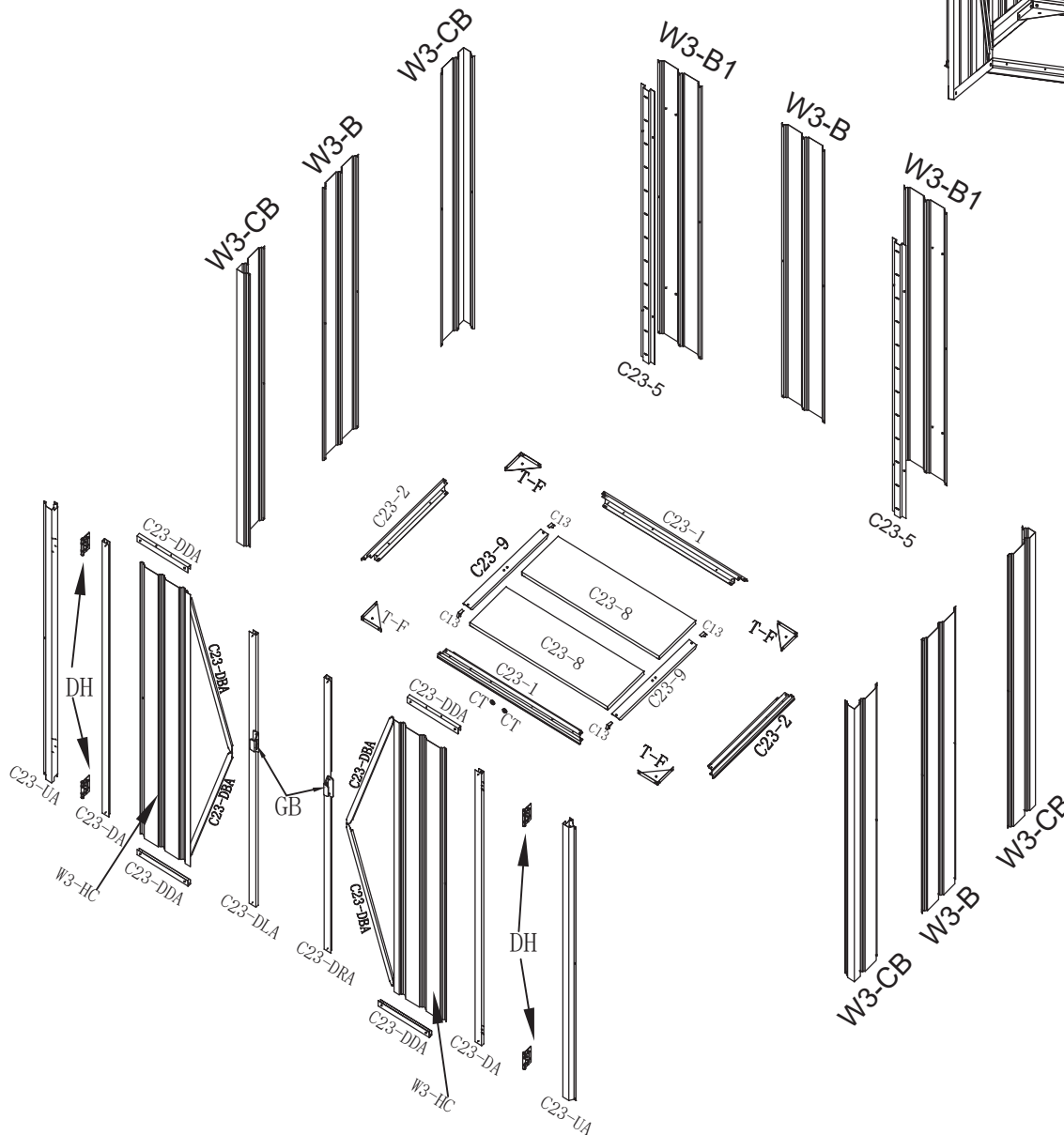
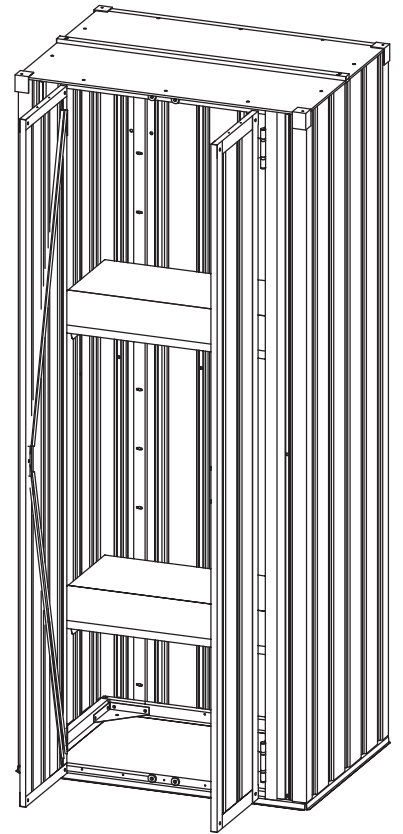

Part List

Side Panels

NO.	W3-CB	W3-B	W3-B1	W3-HC	T-F	CT	DH
QTY.	4	3	2	2	4	2	4
NO.	C13	GB	C23-1	C23-2	C23-5	C23-8	C23-9
QTY.	4	2	2	2	2	2	2
NO.	C23-DA	C23-DDA	C23-DBA	C23-UA	C23-DLA	C23-DRA	
QTY.	2	4	4	2	1	1	



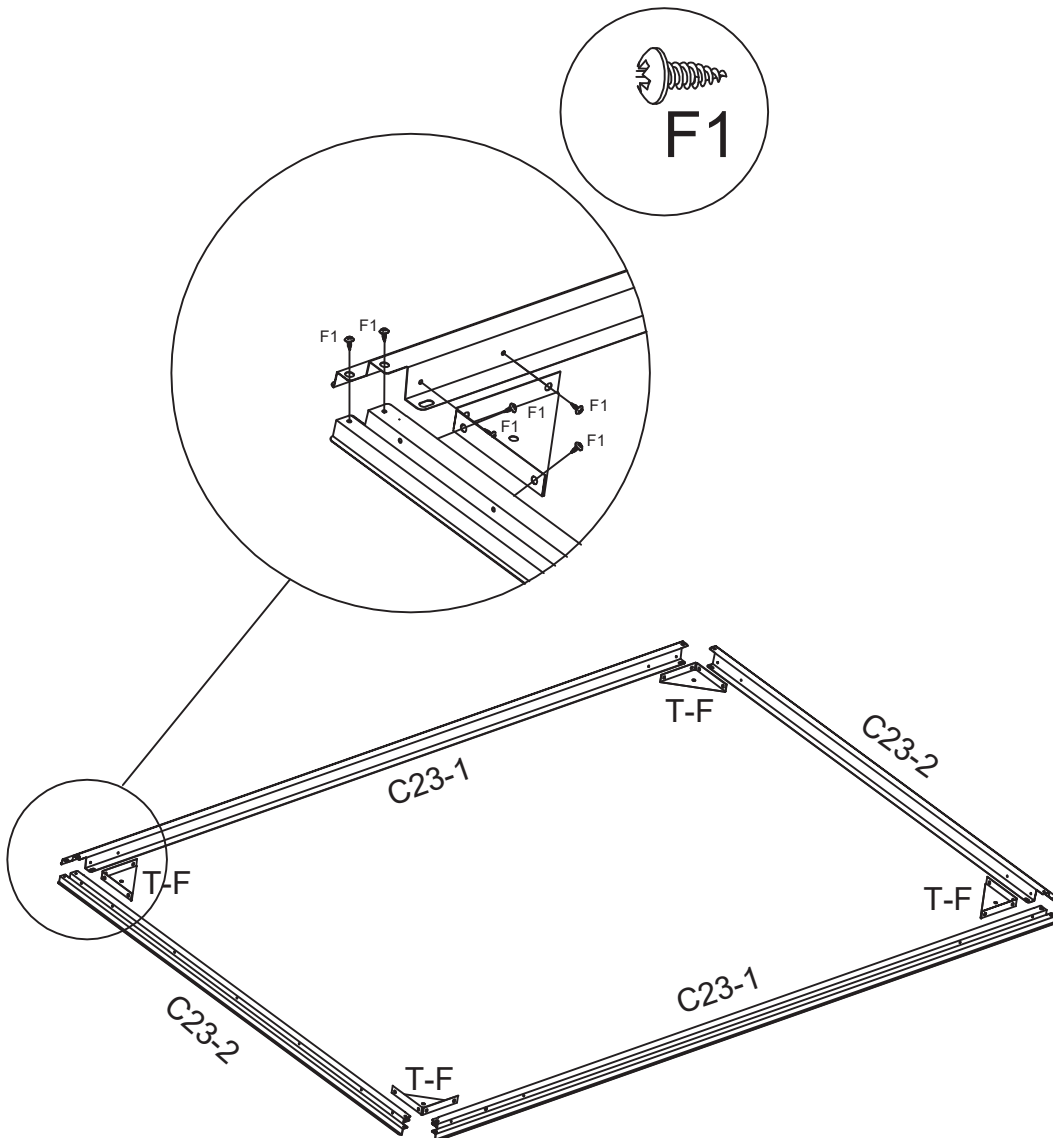

Shed Base Assemble

PART	NO.	QTY.
	C23-1	2
	C23-2	2
	T-F	4
	F1	24



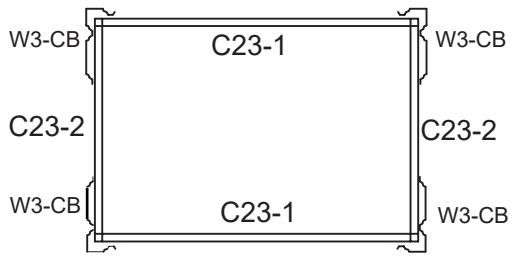



Side Panel Assemble

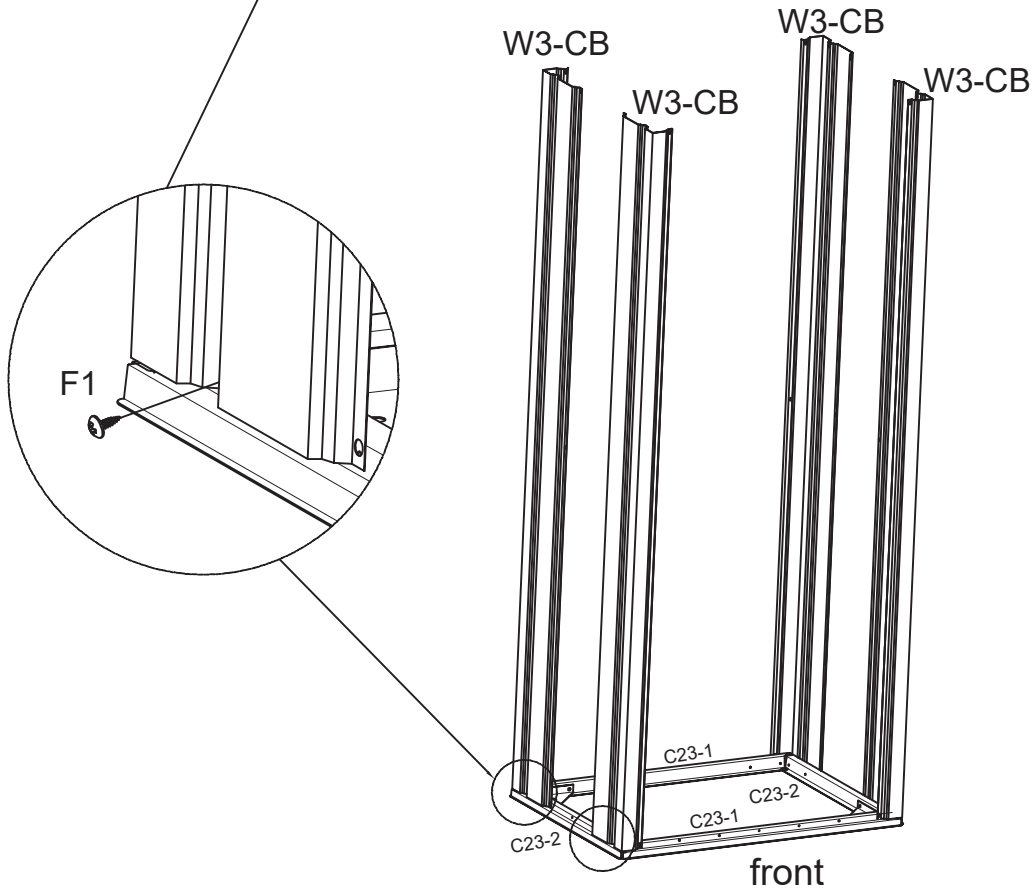
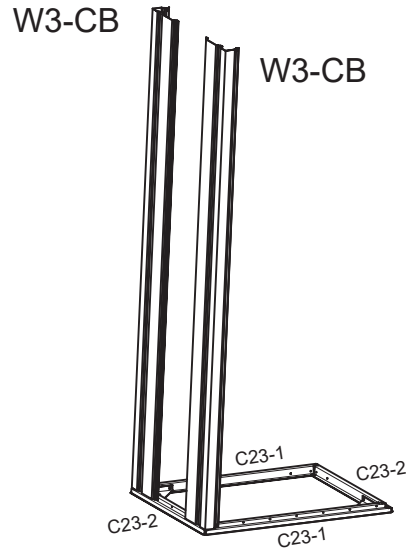
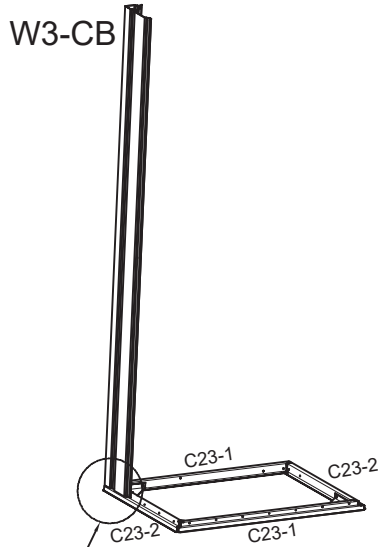





PART	NO.	QTY.
	W3-CB	4
	F1	4

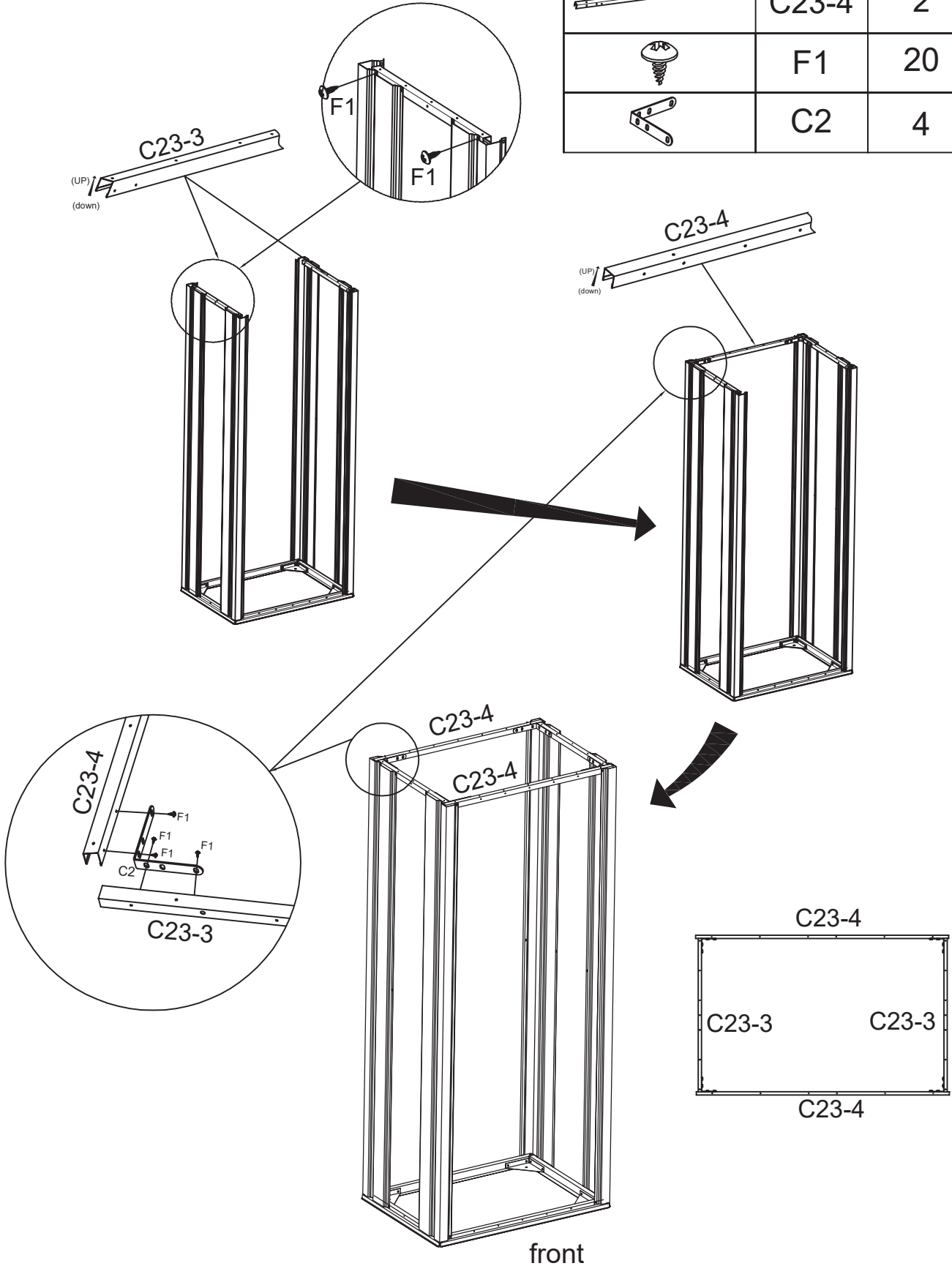

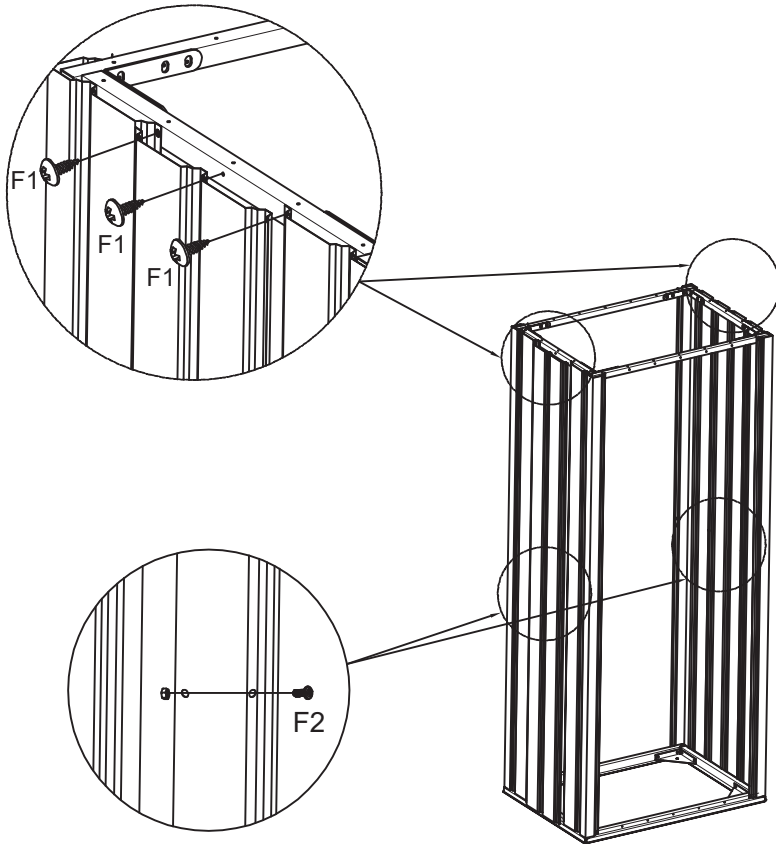



PART	NO.	QTY.
	C23-3	2
	C23-4	2
	F1	20
	C2	4



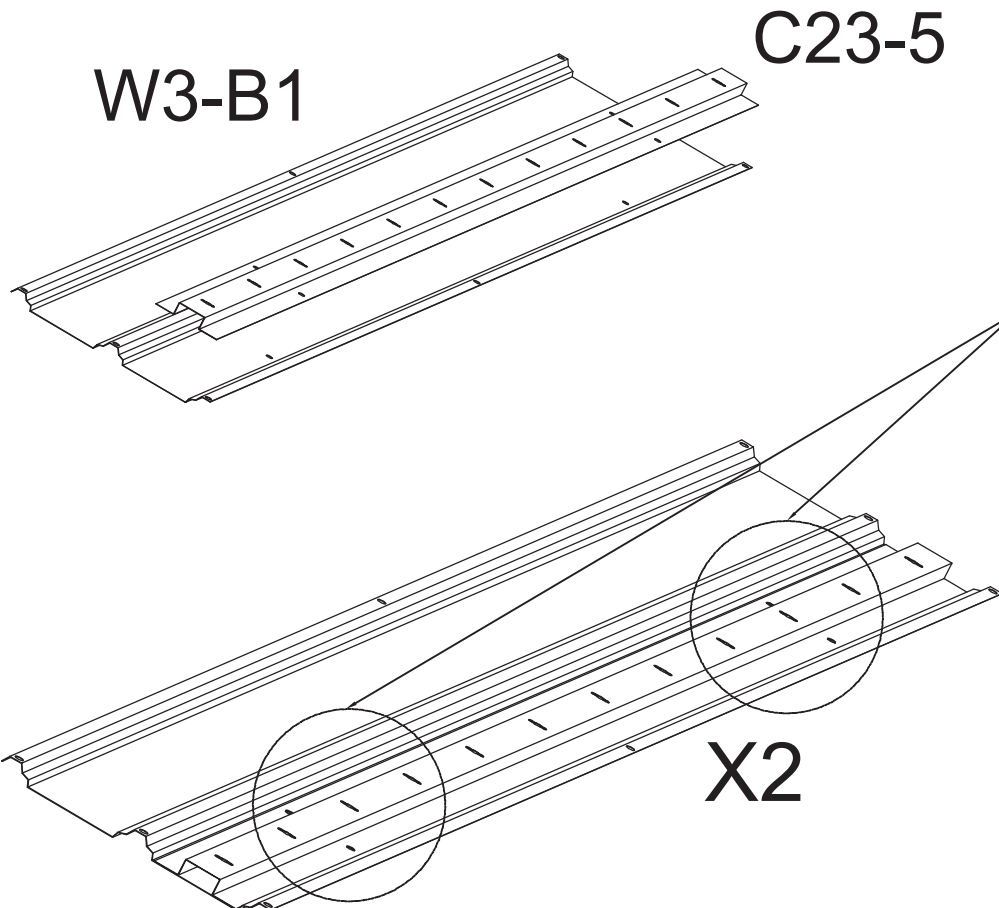
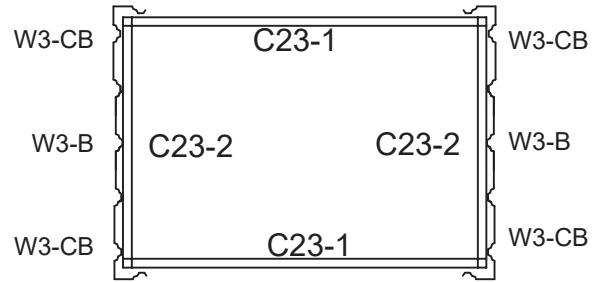





PART	NO.	QTY.
	W3-B	2
	F1	12
	F2	4



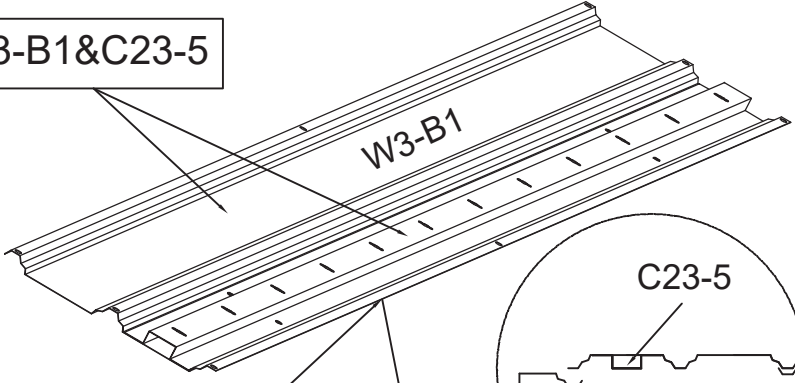



PART	NO.	QTY.
	W3-B1	2
	C23-5	2
	F2	8

W3-B1&C23-5

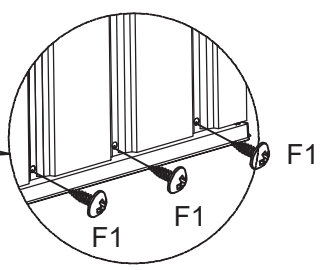
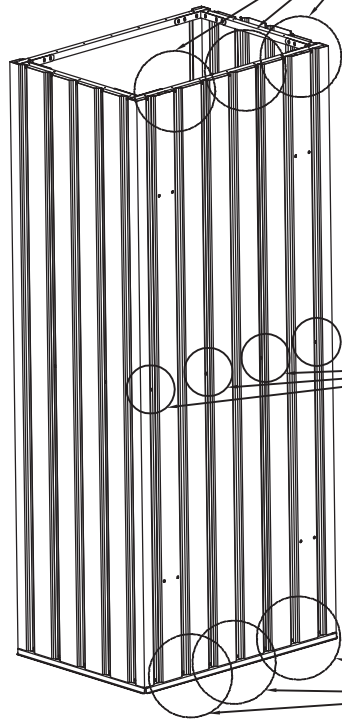
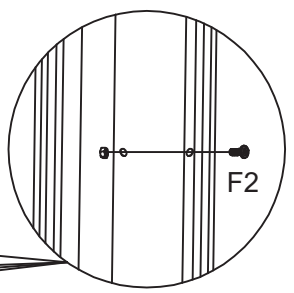
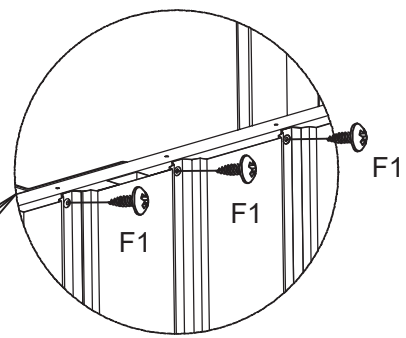
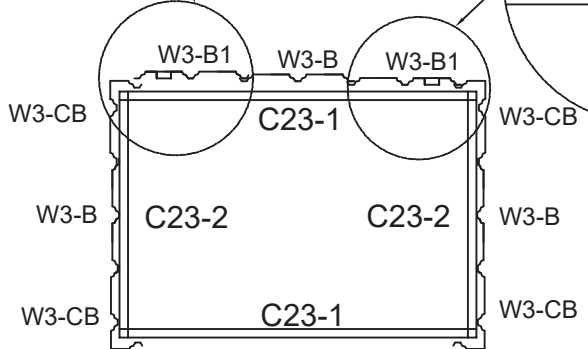
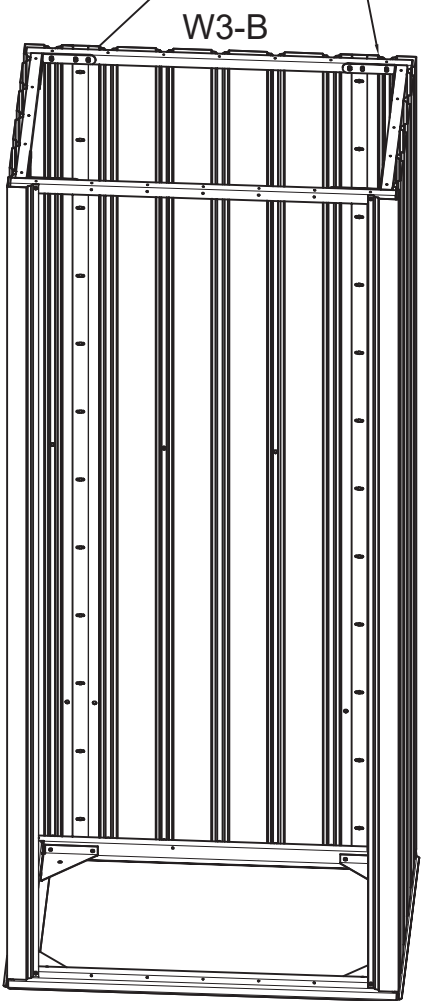
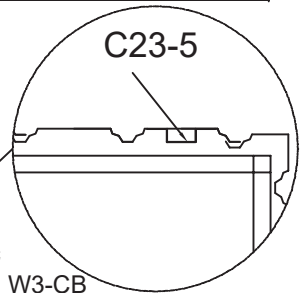
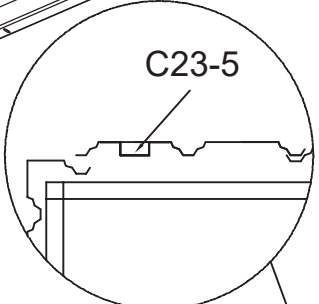

PART	NO.	QTY.
	W3-B	1
	W3-B1&C23-5	2
	F1	14
	F2	4





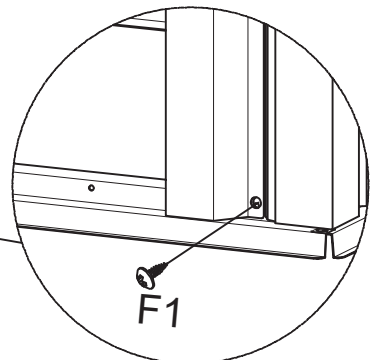
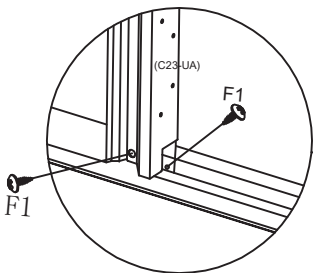
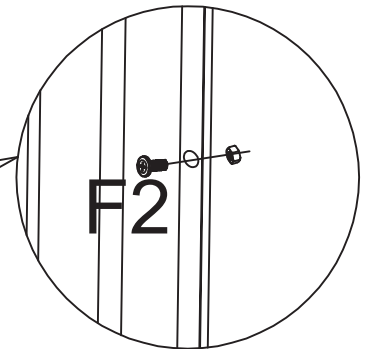
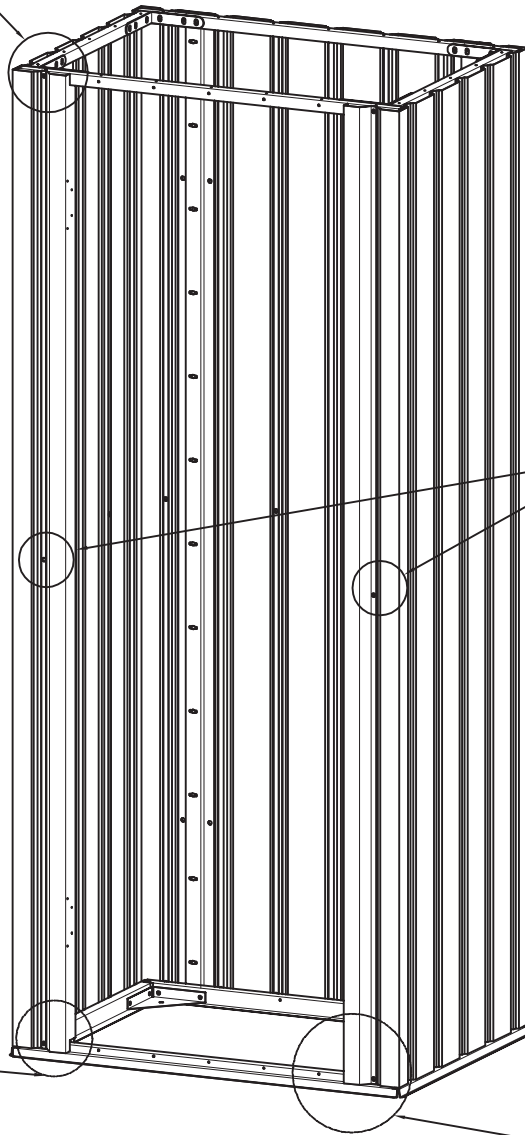
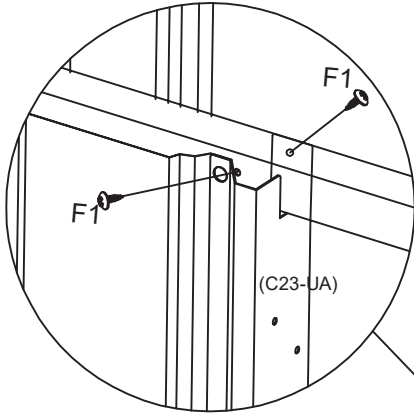

PART	NO.	QTY.
	C23-UA	2
	F1	8
	F2	2

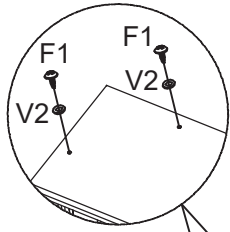

Top Panel Assemble





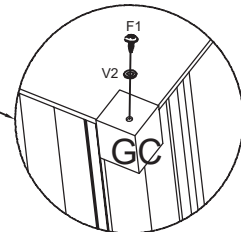
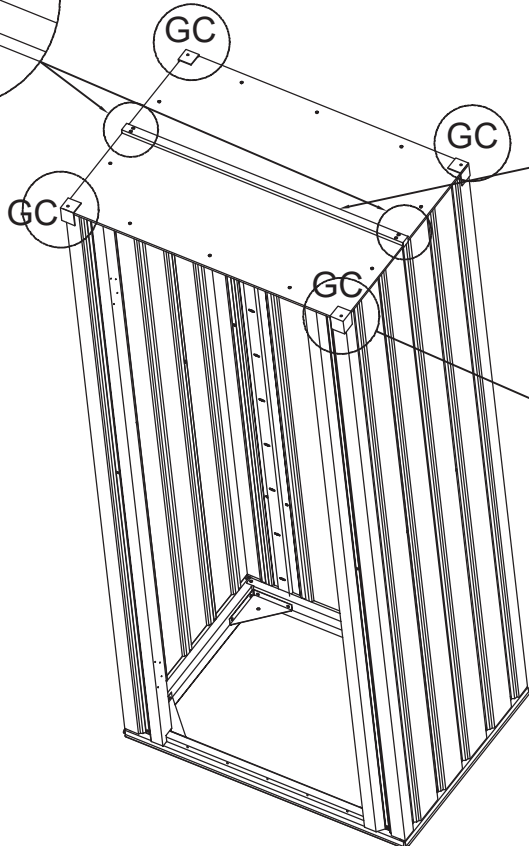
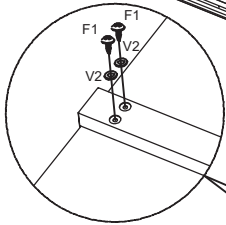
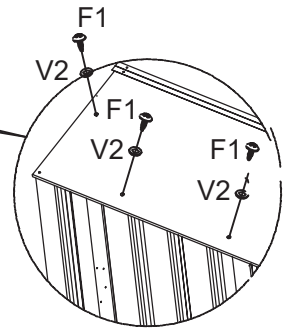
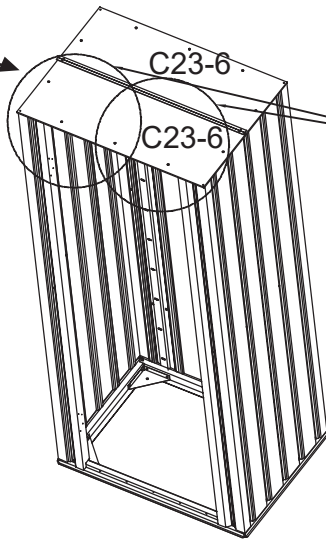
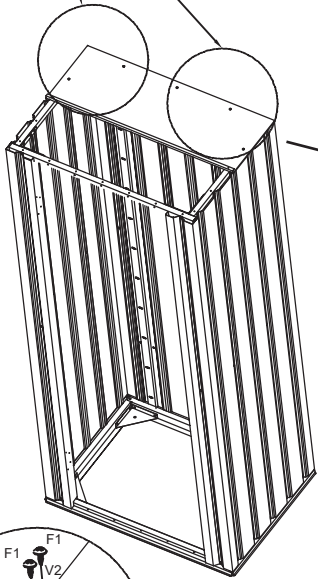



PART	NO.	QTY.
	C23-6	2
	C23-7	1
	GC	4
	F1	18
	V2	18







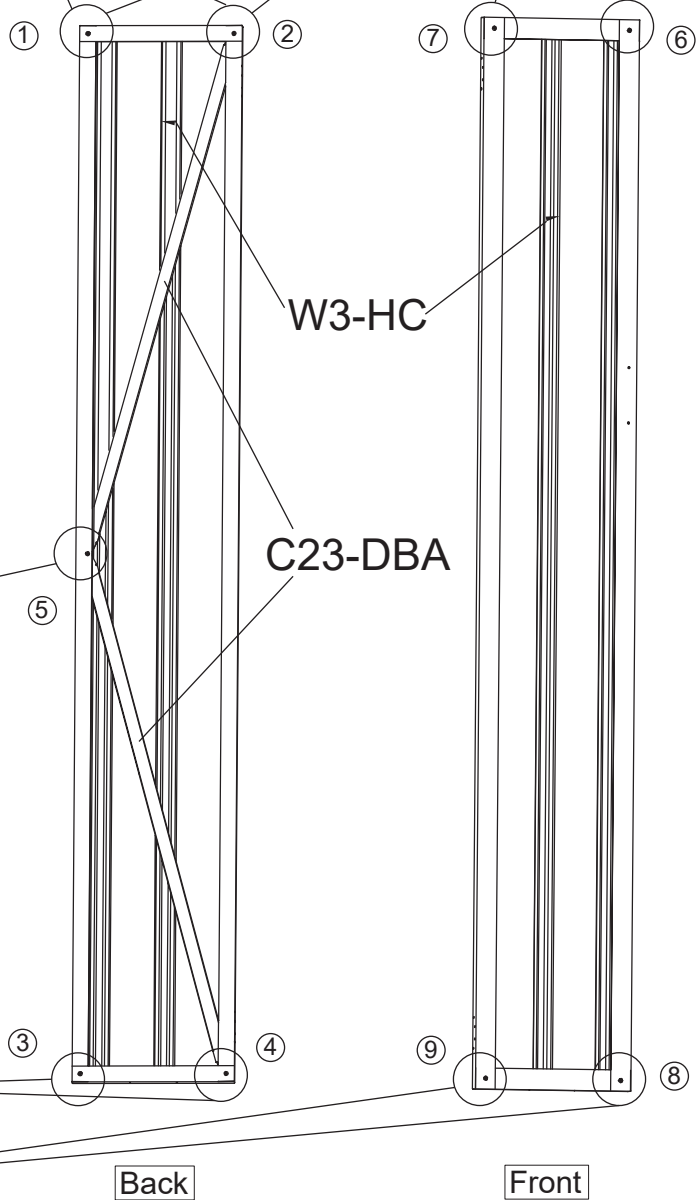
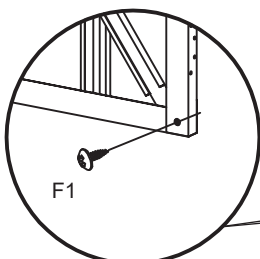
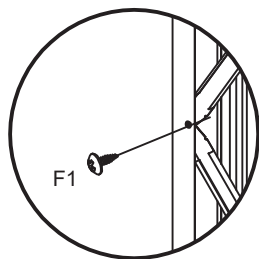
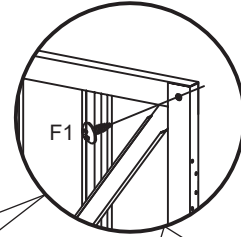
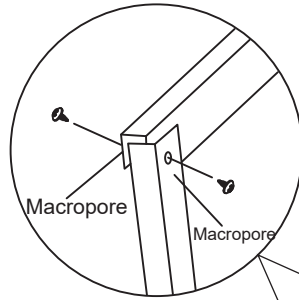
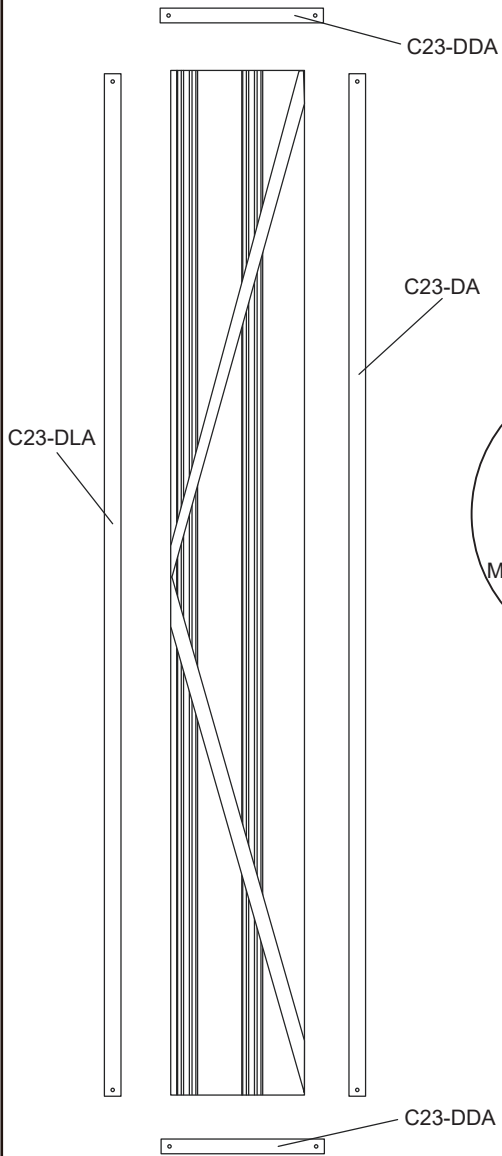

Door Assemble

DL



PART	NO.	QTY.
	W3-HC	1
	C23-DBA	2
	C23-DA	1
	C23-DLA	1
	C23-DDA	2
	F1	9



DR

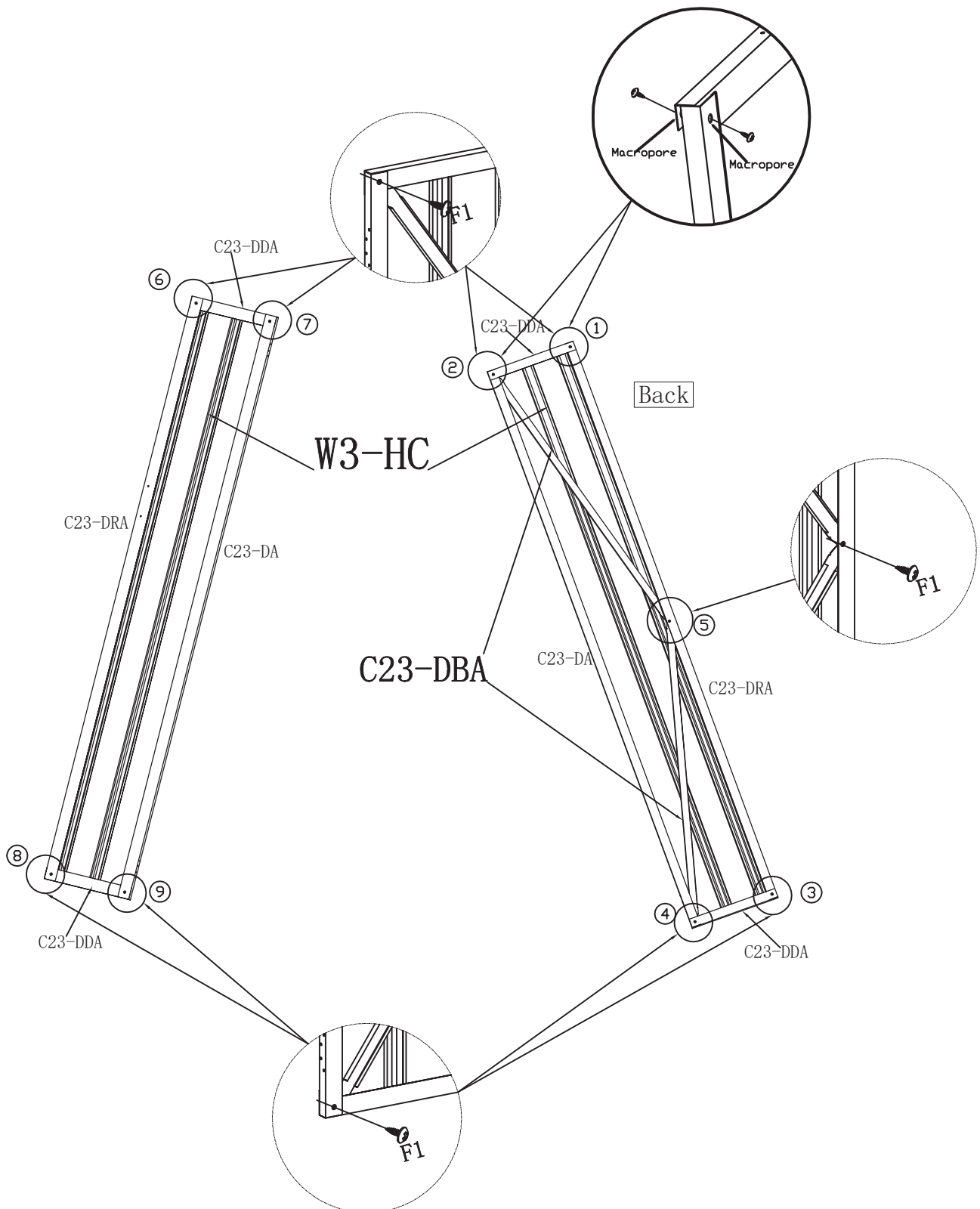

PART	NO.	QTY.
	W3-HC	1
	C23-DBA	2
	C23-DA	1
	C23-DRA	1
	C23-DDA	2
	F1	9

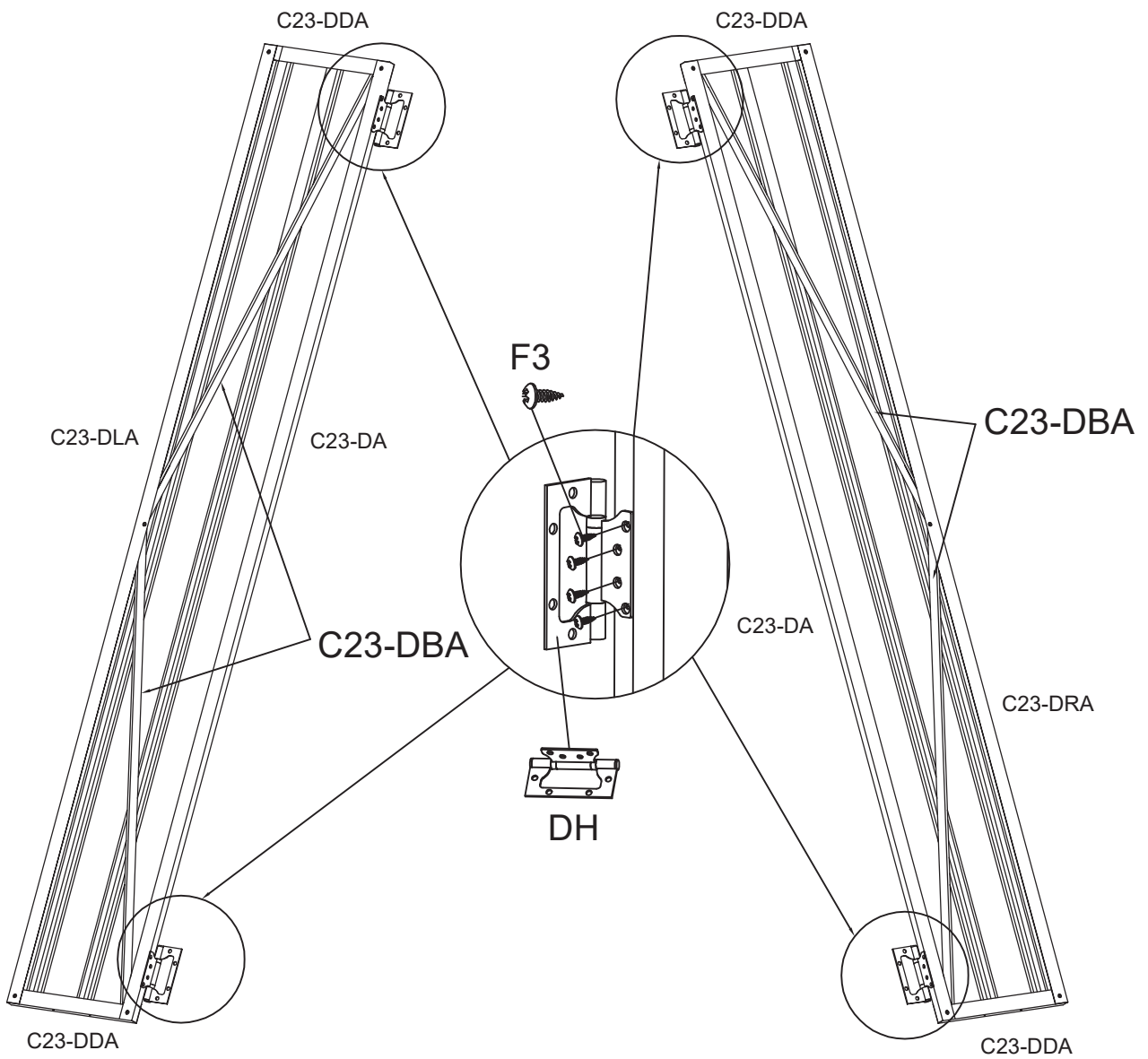

PART	NO.	QTY.
	DH	4
	F3	16

DL DR



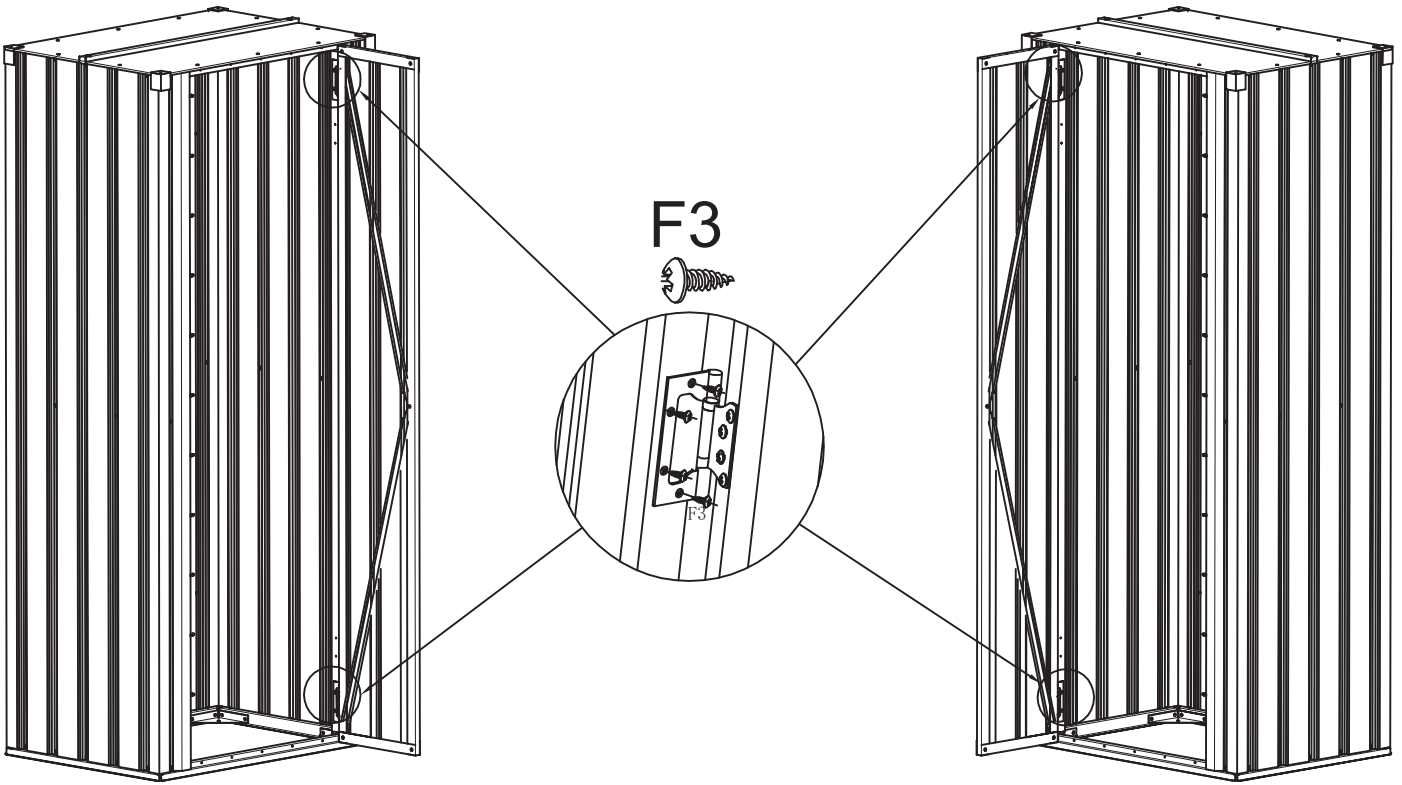

PART	NO.	QTY.
	F3	16
	DL	1
	DR	1



DR

DL

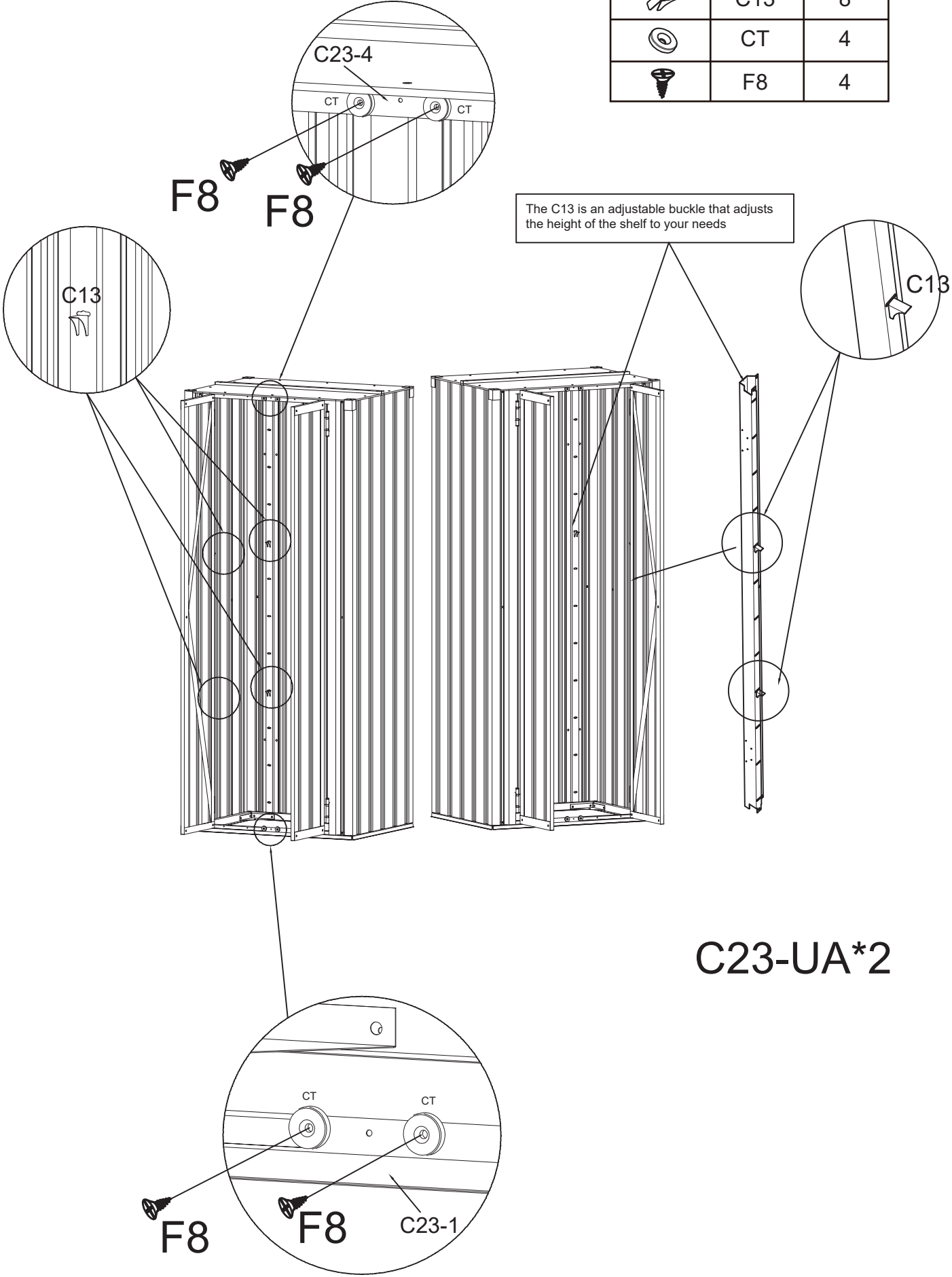

PART	NO.	QTY.
	C13	8
	CT	4
	F8	4



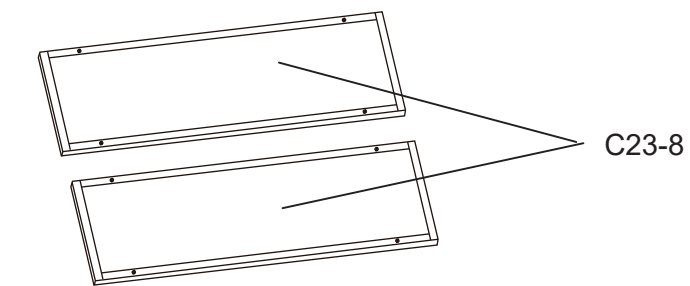

C23-UA*2

Shelf Assemble

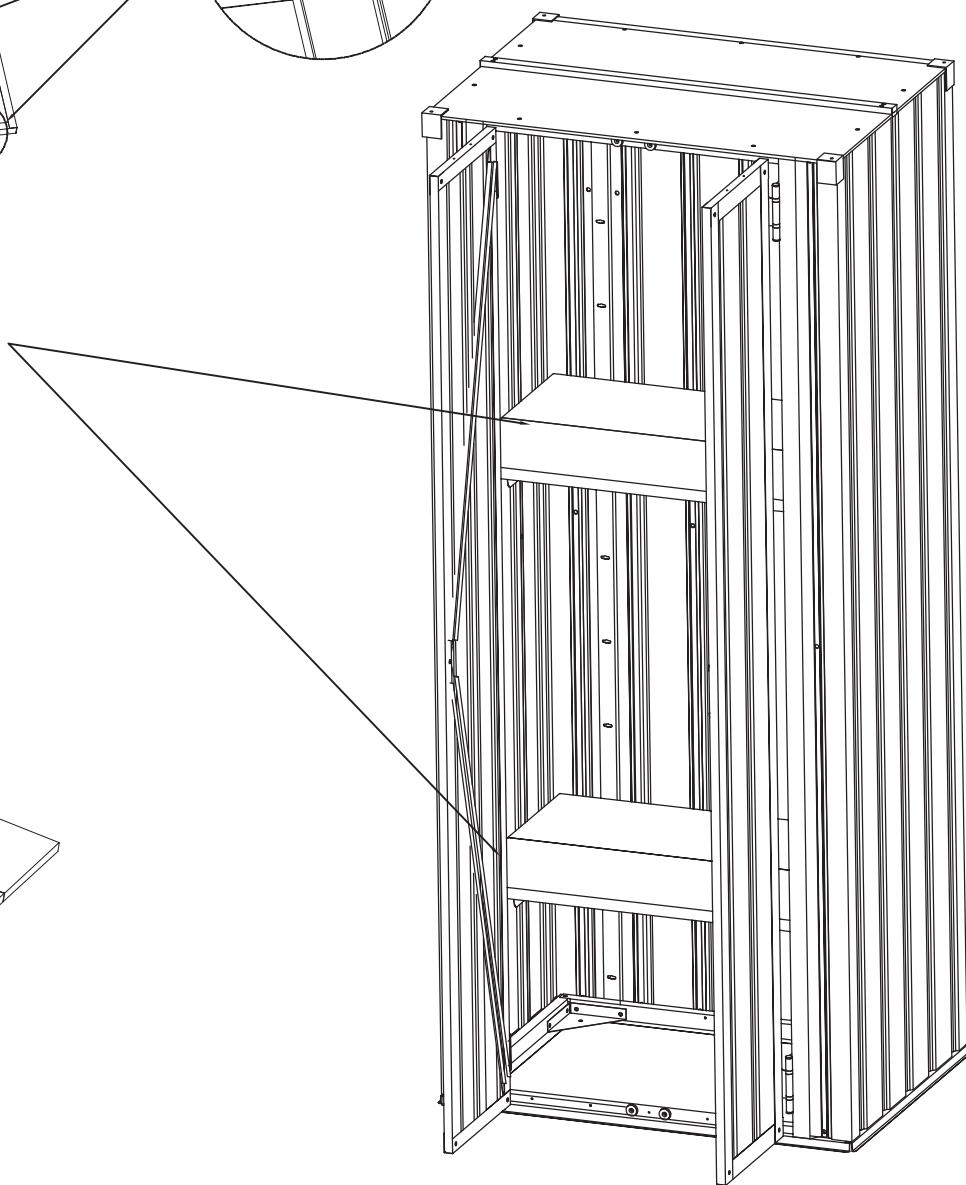
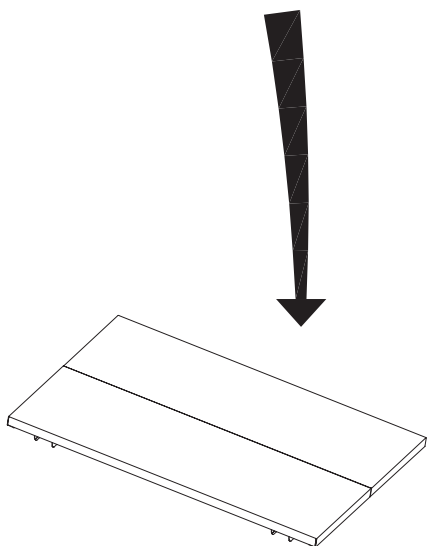
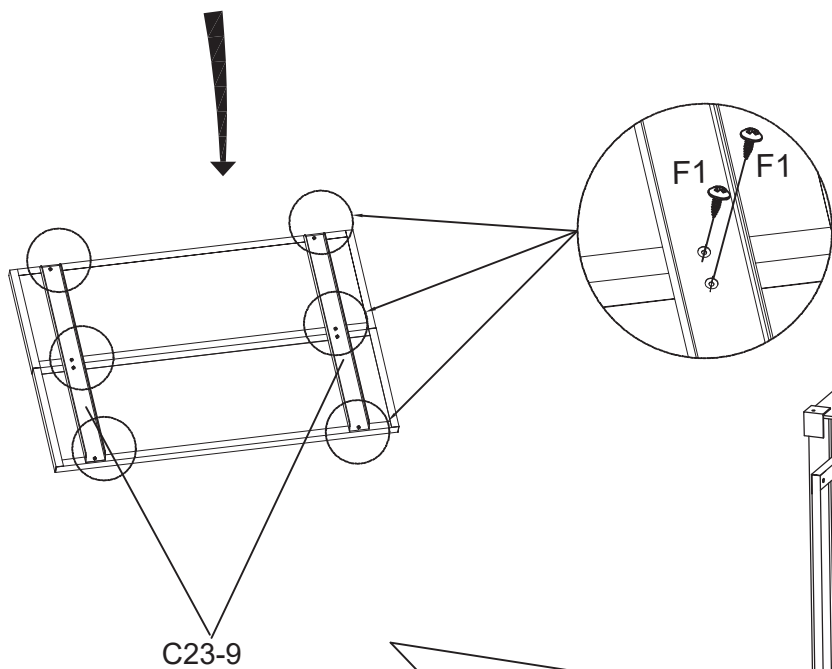

PART	NO.	QTY.
	C23-9	4
	C23-8	4
	F1	16



PART	NO.	QTY.
	GB	2
	F1	4

