

# Planter Box

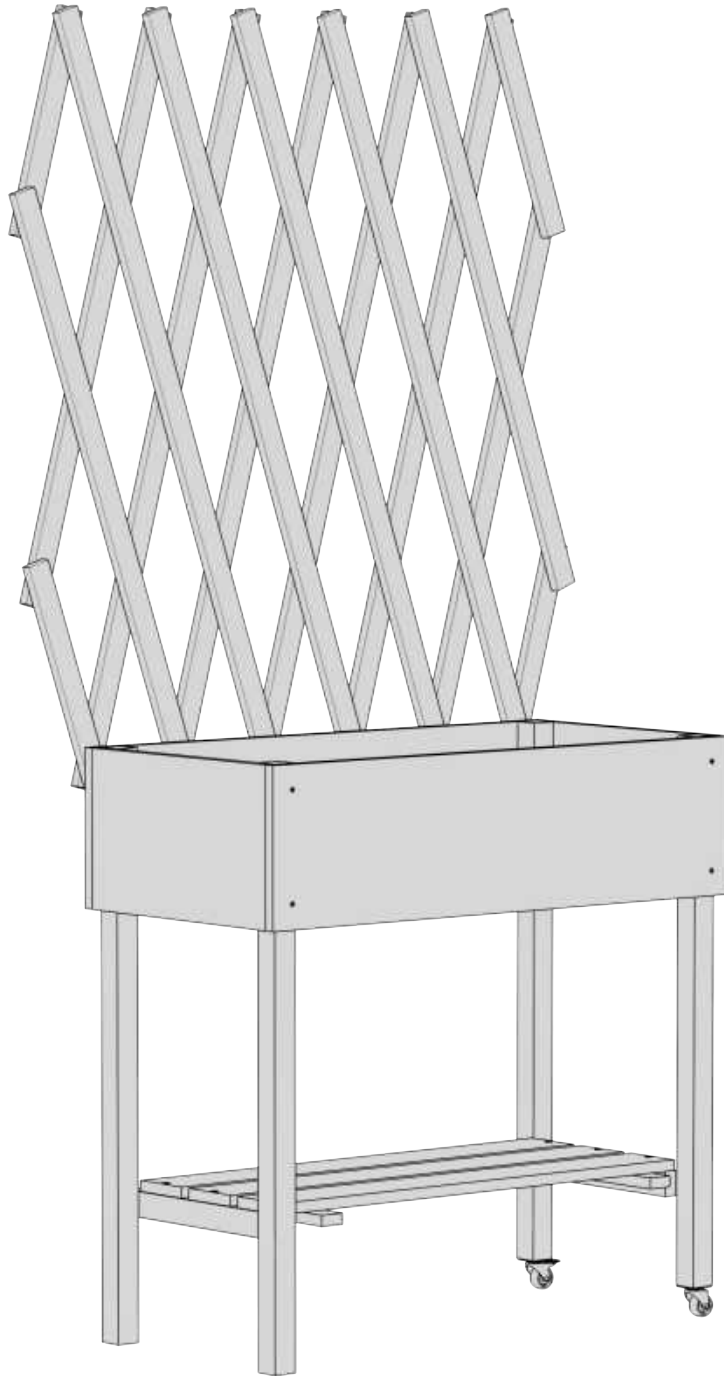

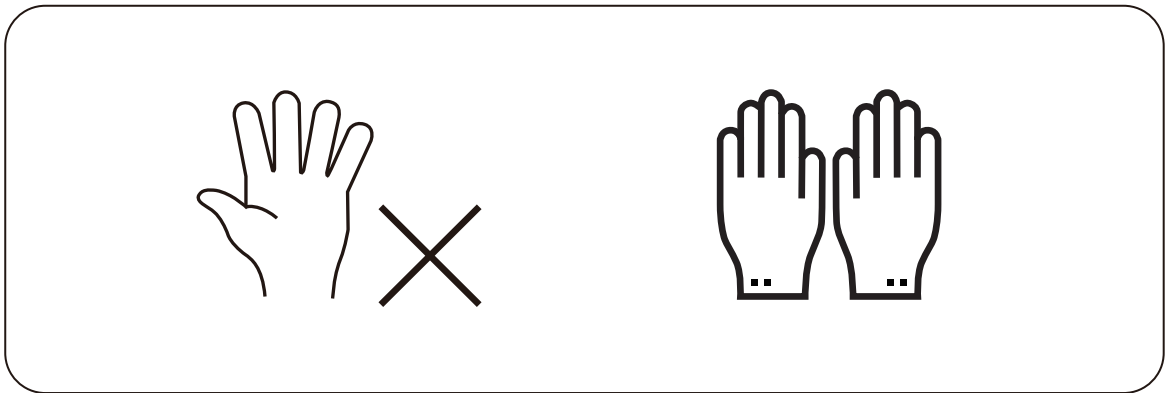





Before assembling, we recommend:

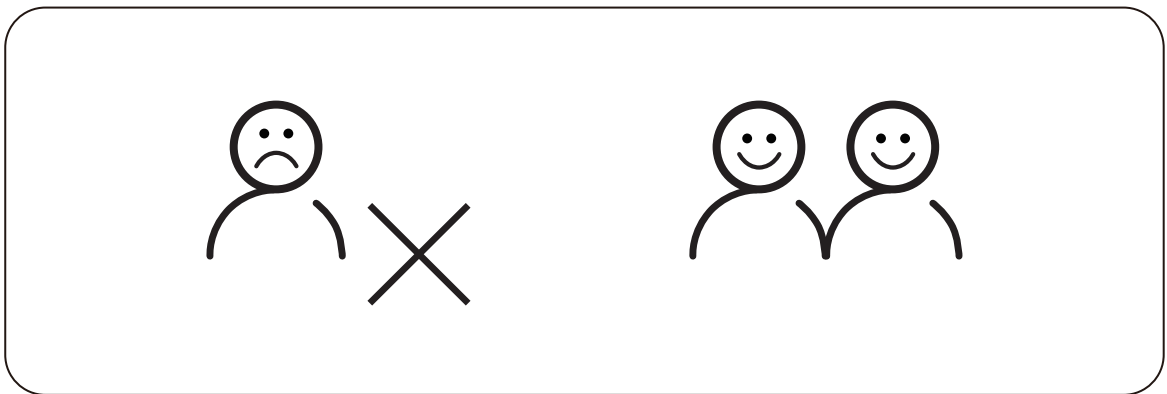





1. Wear Gloves.



2. Asking for a Helping Hand.



				
(A)	(B)	(C)	(D)	(E)
1 pcs	2 pcs	2 pcs	1 pcs	2 pcs

						
Ⓕ	Ⓖ	Ⓗ	Ⓘ	Ⓙ	Ⓚ	Ⓛ
2 pcs	2 pcs	4 pcs M4×40	6 pcs M3.5×30	8 pcs M3.5×25	1 pcs	1 pcs

## Assembly Instructions

**Step 1**

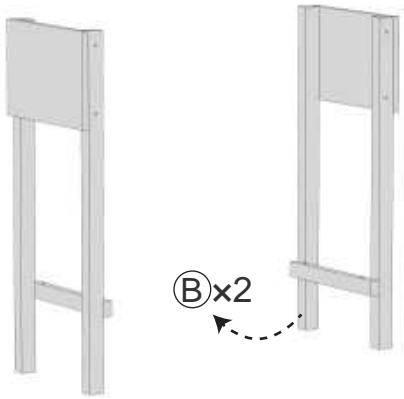

**Step 2**

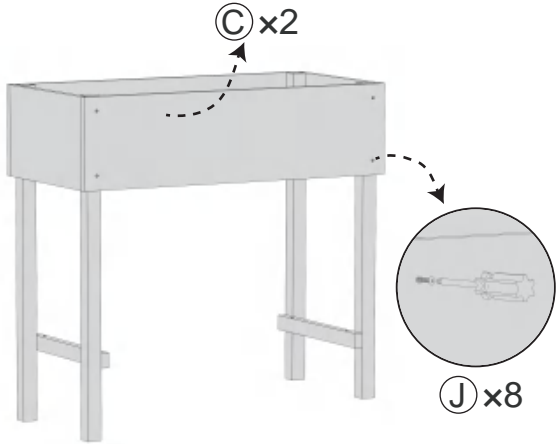

**Step 3**

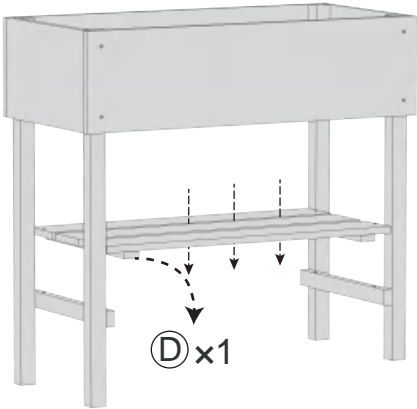

**Step 4**

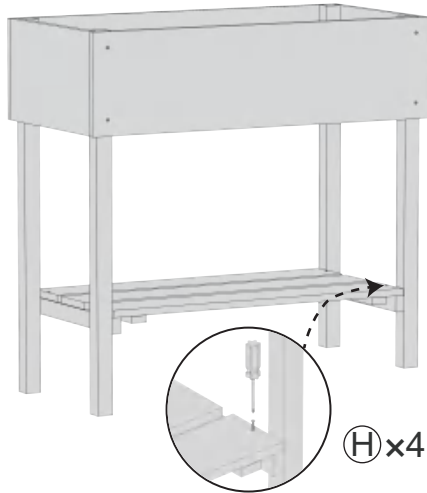

**Step 5**

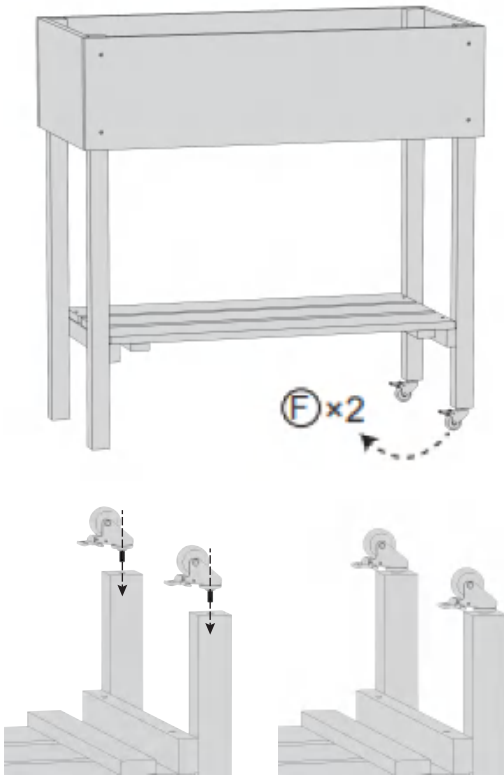

Invert the assembly and attach the casters.

**Step 6**



**Step 7**



Planter box assembly complete.

**Two Ways to Assemble :**

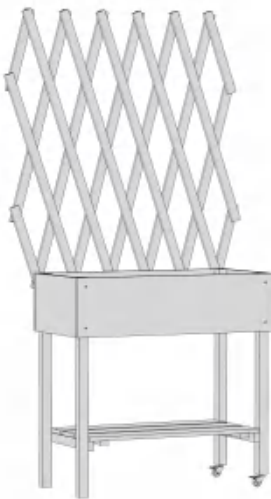

**Option 1: Integrated Setup (Trellis + Box)**

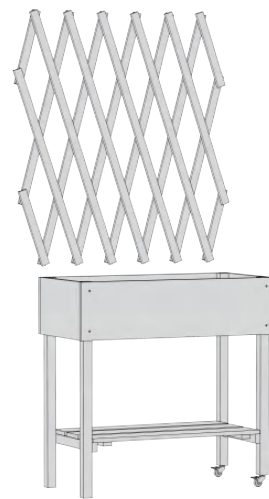



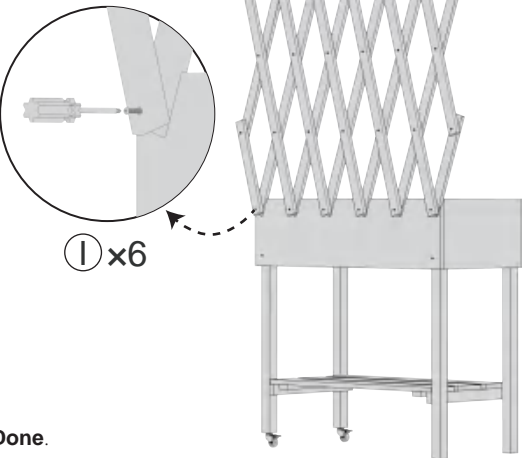

**Option 2: Standalone Setup (Trellis & Box Separate)**

## Combined Assembly:

<p><b>Step 1</b></p>  <p>Remove the 6 screws located on the lowest row.</p>	<p><b>Step 2</b></p>  <p>Done.</p>
--	--

## Separate Assembly (Before you begin, please prepare the following tools.)

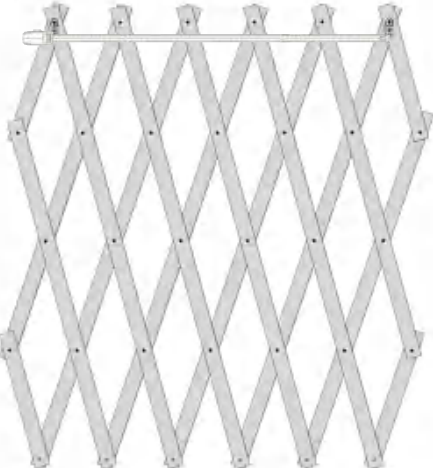
 <p><b>Electric Drill</b></p>	<p>Note: These tools are not included in the toolkit.</p>  <p><b>Tape Measure</b></p>  <p><b>Pencil</b></p>
---	---

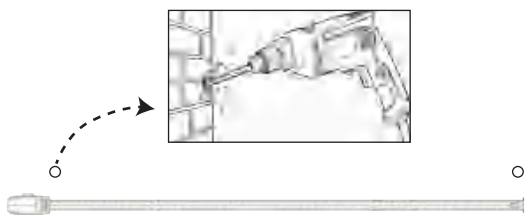
<p><b>Step 1</b></p>  <p>Use a tape measure to measure the distance between the two hooks on the back of the trellis.</p>	<p><b>Step 2</b></p>  <p>Use a tape measure and pencil to mark the drilling locations on the wall.</p> <p><b>Step 3</b></p>  <p>Drill holes at the marked locations using an electric drill.</p>
--	--

Step 4

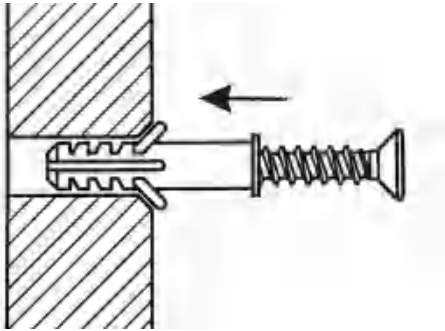

Insert two wall anchors into the holes.

Step 5

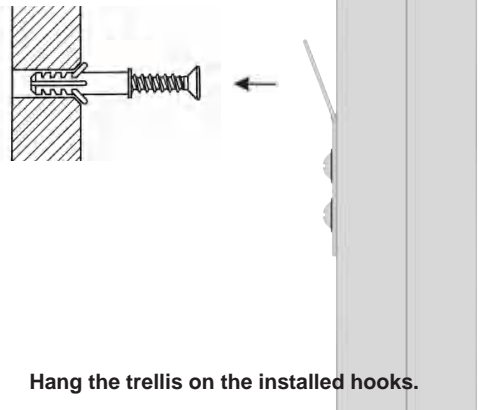

Hang the trellis on the installed hooks.

Step 6

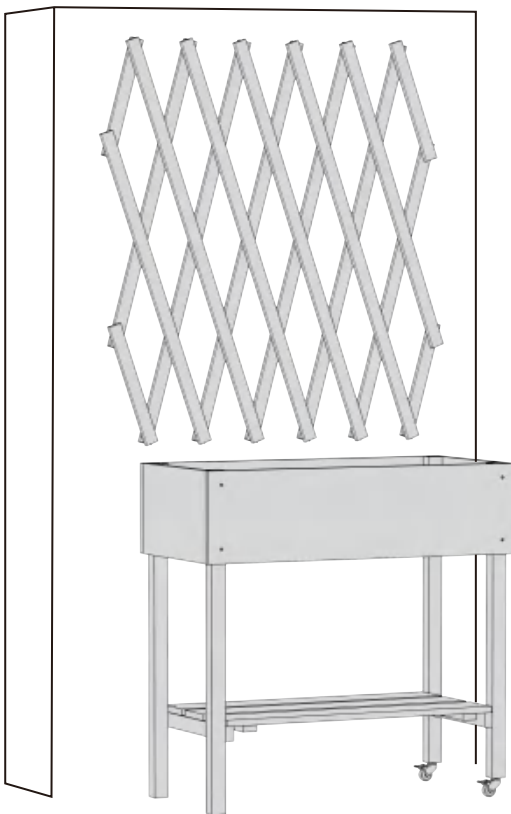

Done.

Step 7

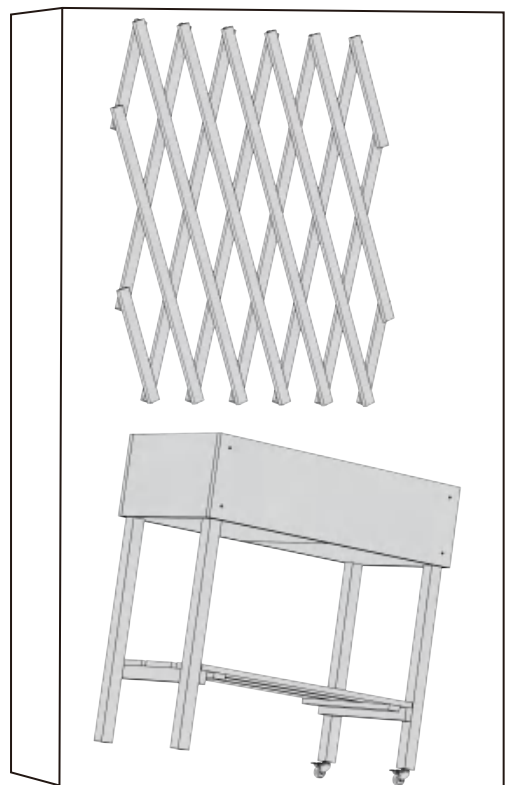

Features two lockable wheels for easy movement.