

English

WARNING



Children have died from furniture tipover. To reduce the risk of furniture tipover:

- ALWAYS install tipover restraint provided.
- NEVER put a TV on this product.
- NEVER allow children to stand, climb or hang on drawers, doors, or shelves.
- NEVER open more than one drawer at a time.
- Place heaviest items in the lowest drawers.
- Do not defeat or remove the drawer interlock system.

This is a permanent label.

Do not remove!

French

ATTENTION



Des enfants sont morts du basculement des meubles. Pour réduire le risque de basculement des meubles:

- TOUJOURS installer la retenue de basculement fournie.
- NE JAMAIS mettre de téléviseur sur ce produit.
- NE JAMAIS permettre aux enfants de se tenir debout, de grimper. ou de s'accrocher à des tiroirs, des portes ou des étagères.
- N'ouvrez JAMAIS plus d'un tiroir à la fois.
- Placez les objets les plus lourds dans les tiroirs les plus bas.
- Ne désactivez pas et ne retirez pas le système de verrouillage du tiroir.

Ceci est une étiquette permanente.

Ne pas enlever!

German

WARNUNG





Kinder sind an einem Möbelkippen gestorben. So verringern Sie das Risiko eines Umkippens von Möbeln:







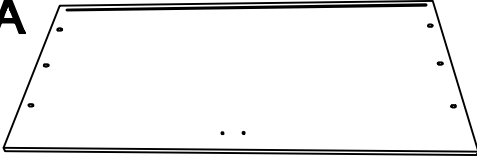
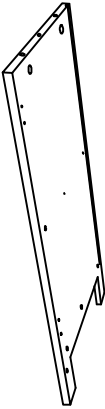
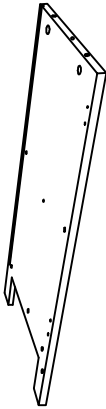
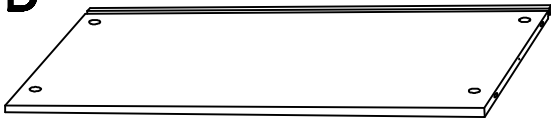
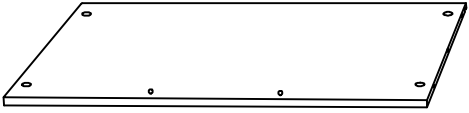

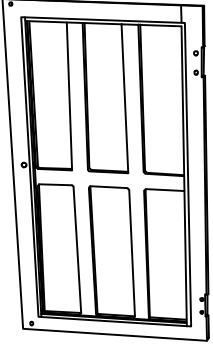
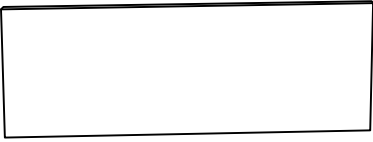

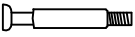





- Installieren Sie IMMER die mitgelieferte Kipprückhaltevorrichtung.
- Stellen Sie NIEMALS einen Fernseher an dieses Produkt.
- Lassen Sie Kinder NIEMALS an Schubladen, Türen oder Regalen stehen klettern oder hängen.
- Öffnen Sie NIEMALS mehr als eine Schublade gleichzeitig.
- Legen Sie schwerste Gegenstände in die untersten Schubladen.
- Besiegen oder entfernen Sie das Schubladenverriegelungssystem nicht.

Dies ist ein dauerhaftes Etikett.

Nicht entfernen!

Parts list

A  x1	B  x1	C  x1	
D  x1			
E  x1	F  x1		
G  x2	H  x2		

a  x16	b  x16	c  x6	d 3x12mm  x 19	e  x4	f 4x18mm  x2	g  x2	h  x2
i  x1	j  x1	k 3.5x12mm  x4	l 3x20mm  x1	m  x1	n 2.5x12mm  x2	o  x4	p  x1

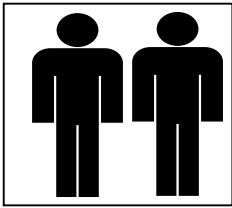
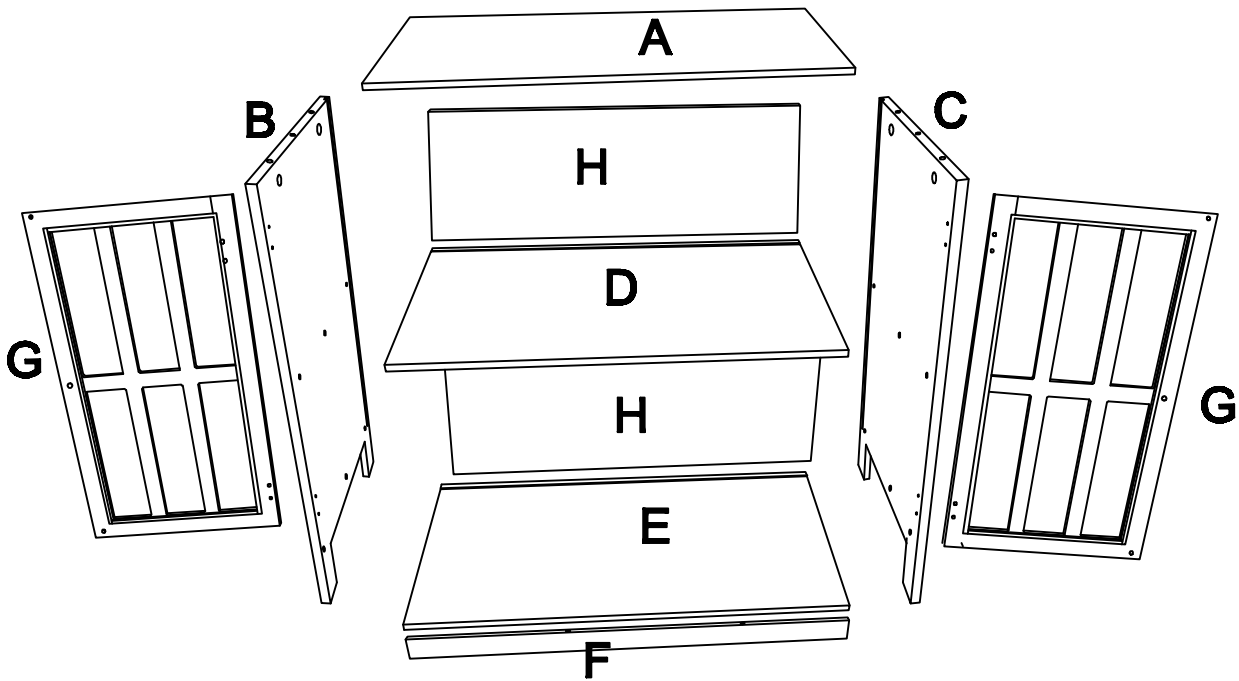

Overview



Two adults required to complete assembly



Assembly Steps

STEP 1

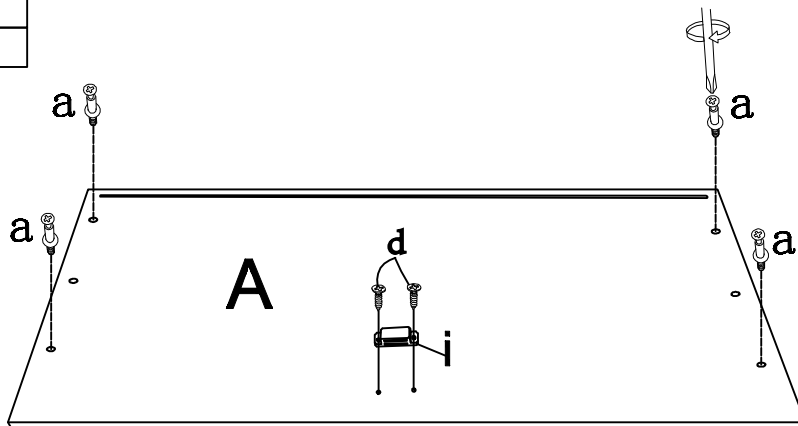
	a×4
	d×2
	i×1



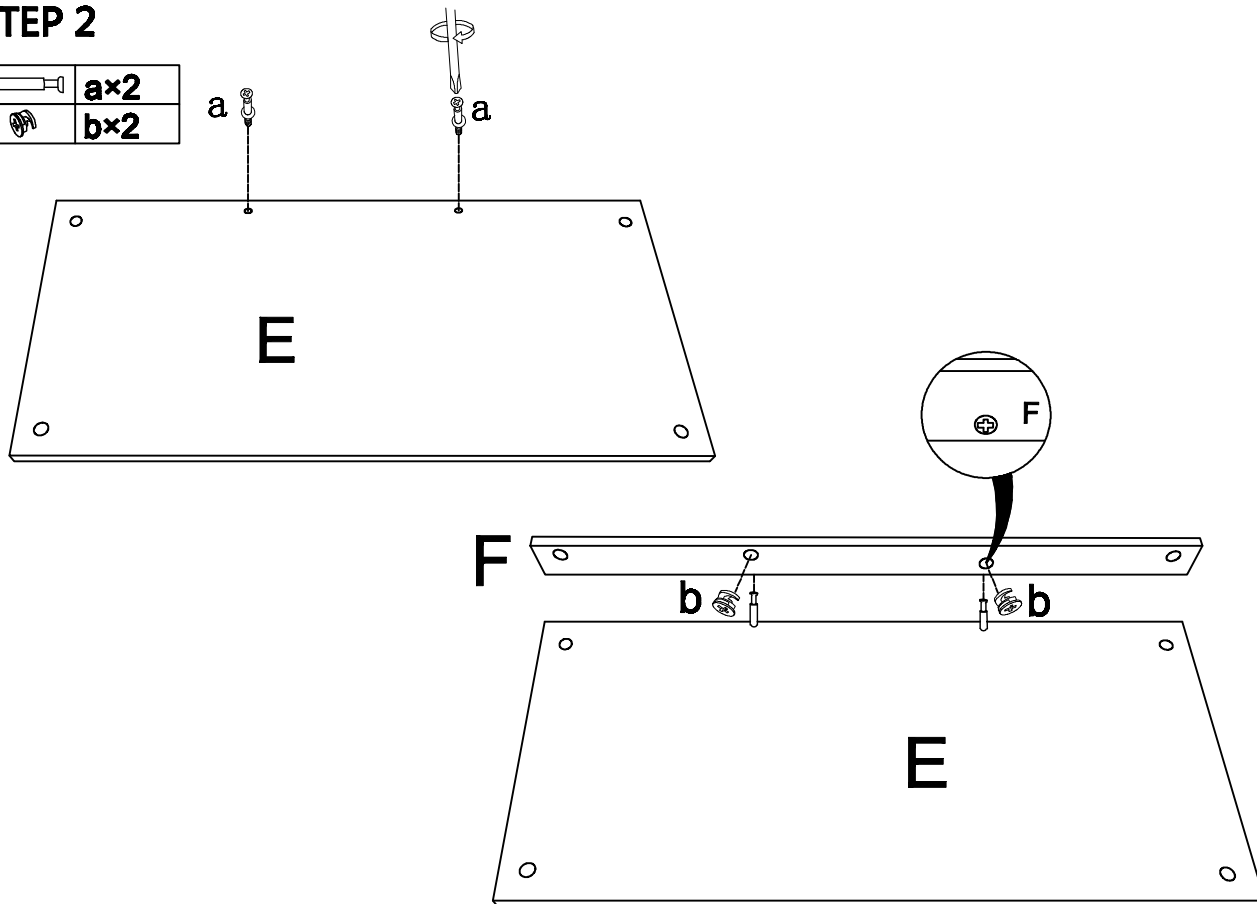

STEP 2

	a×2
	b×2



STEP 3

	a×5
	c×2

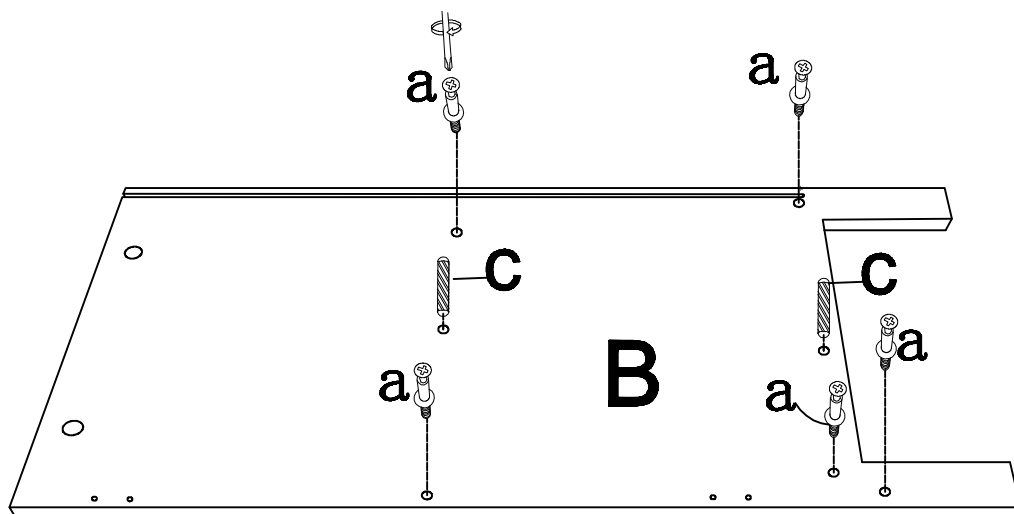

STEP 4

 b×5

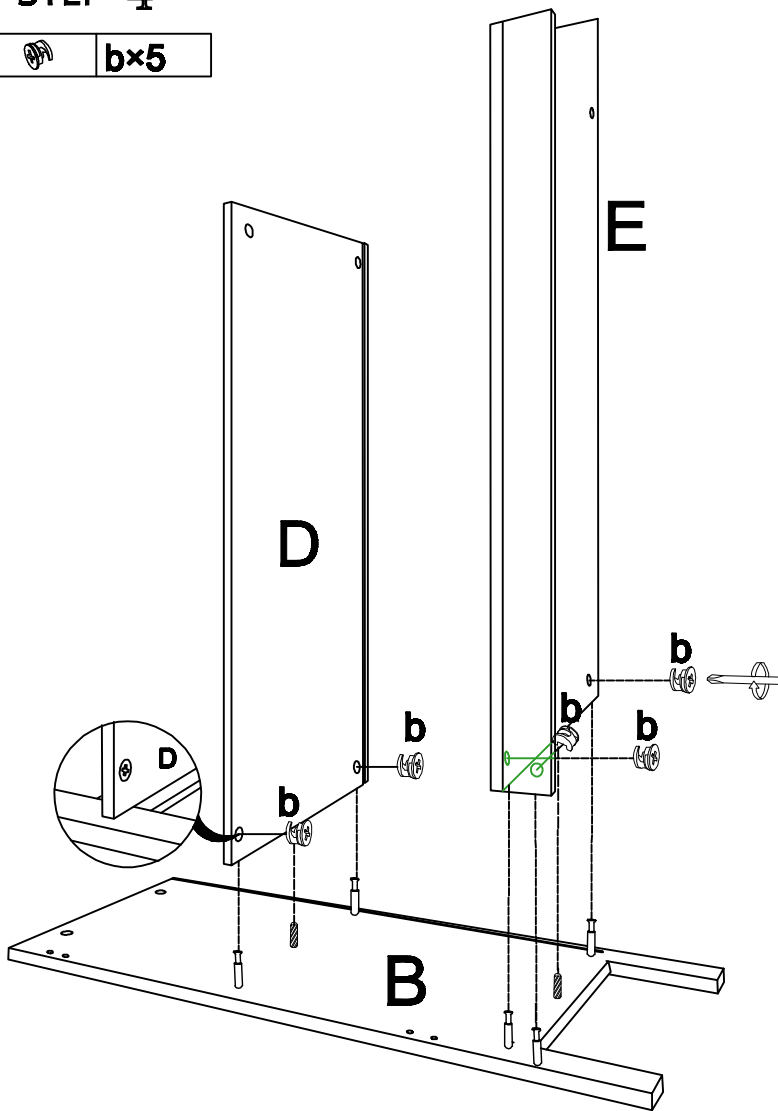

STEP 5

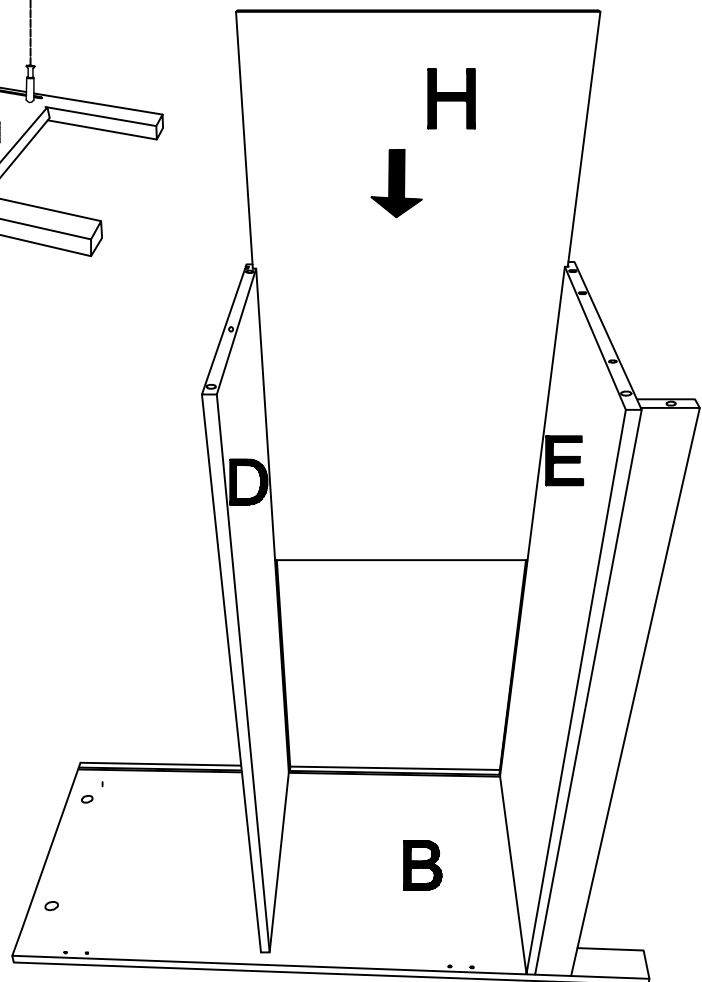

STEP 6

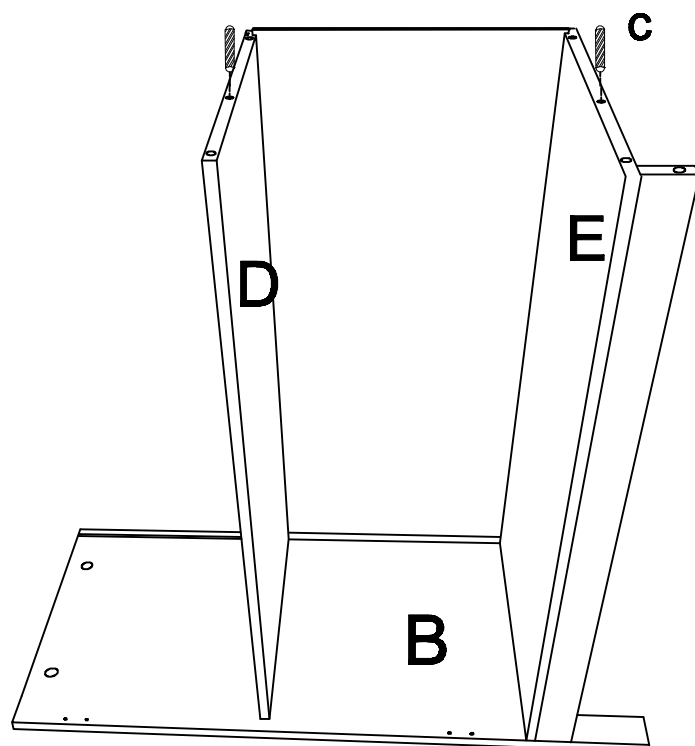

STEP 7

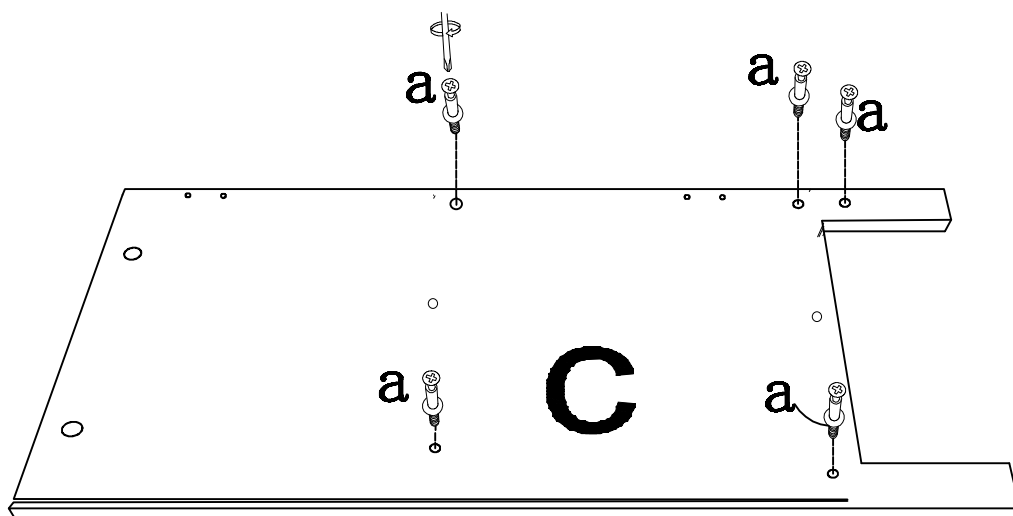
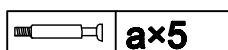

STEP 8

 b×5

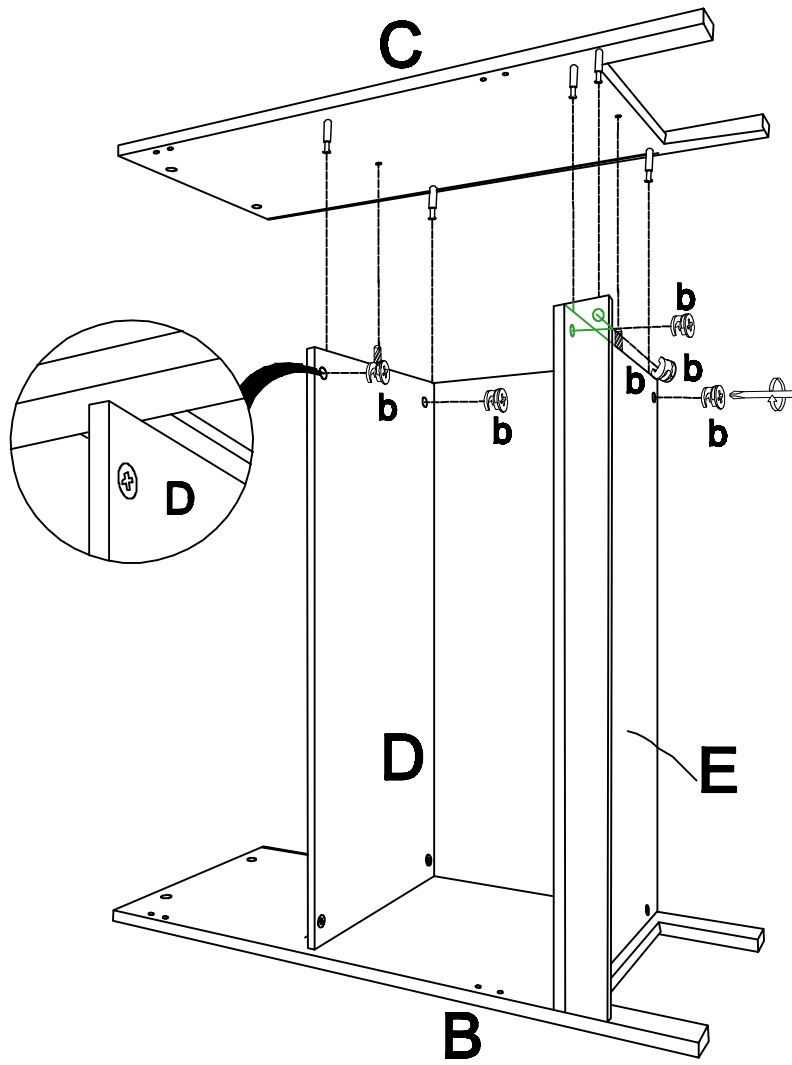

STEP 9

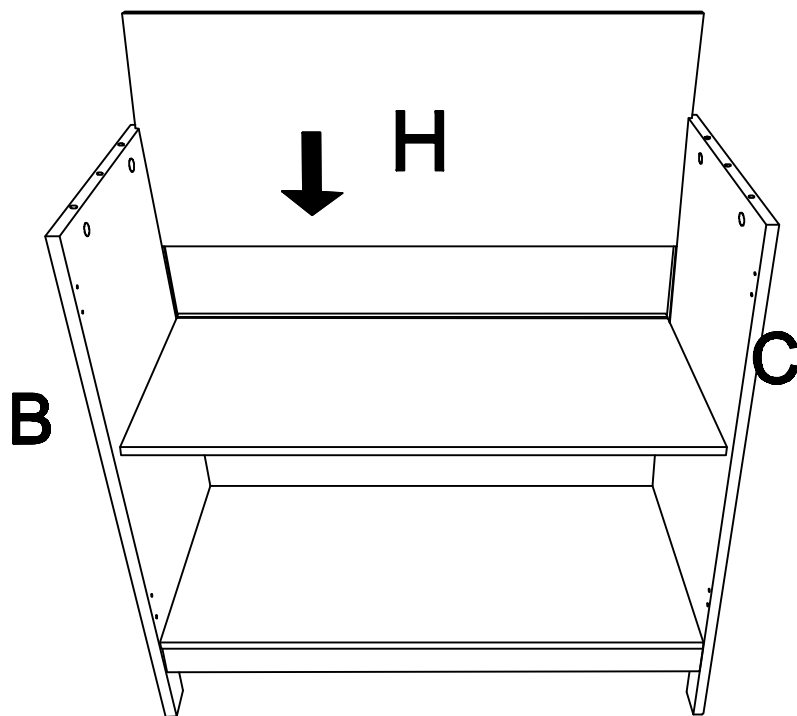

STEP 10

 c×2

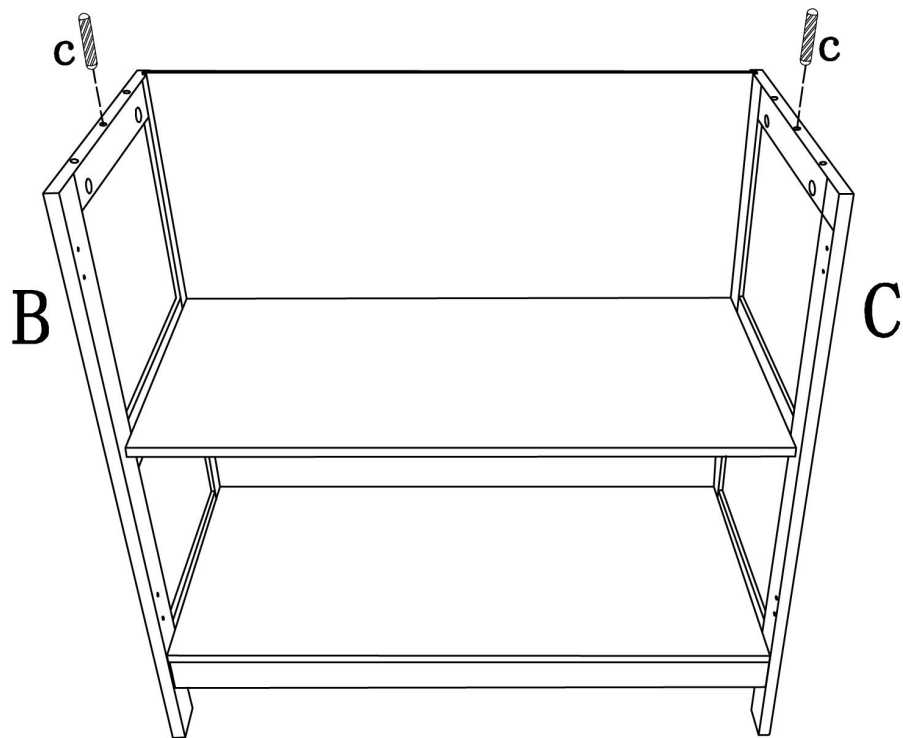





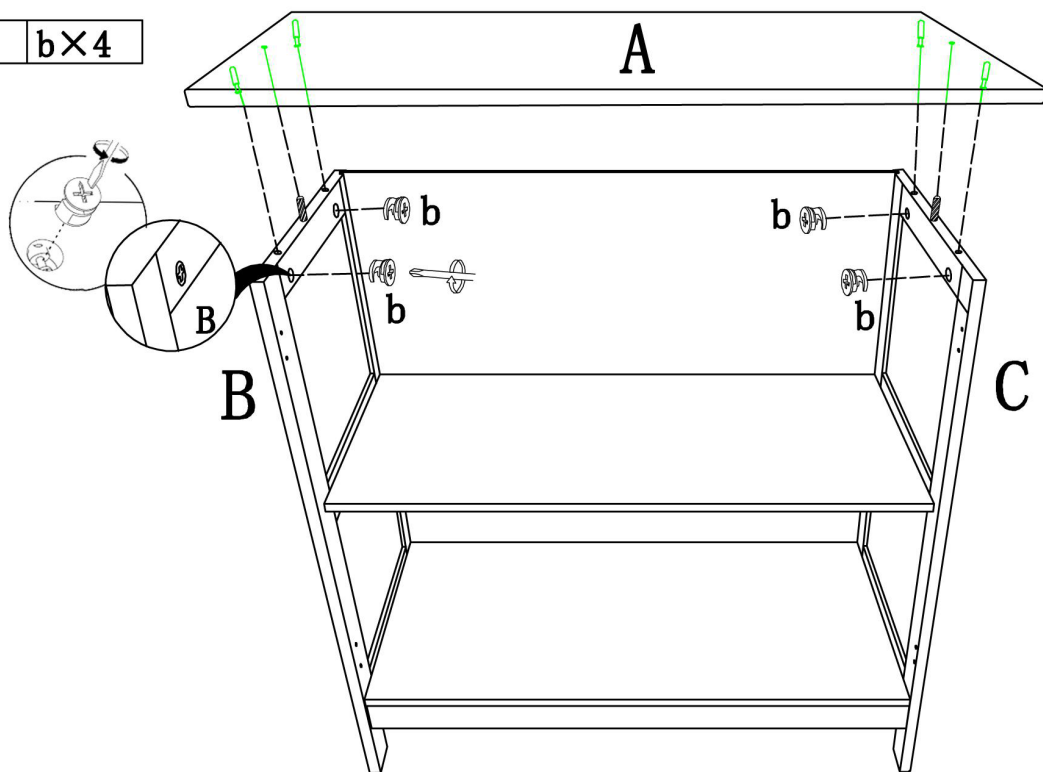

STEP 11

 b×4



STEP 12

	d×8
	e×4
	f×2
	g×2
	h×2
	n×2

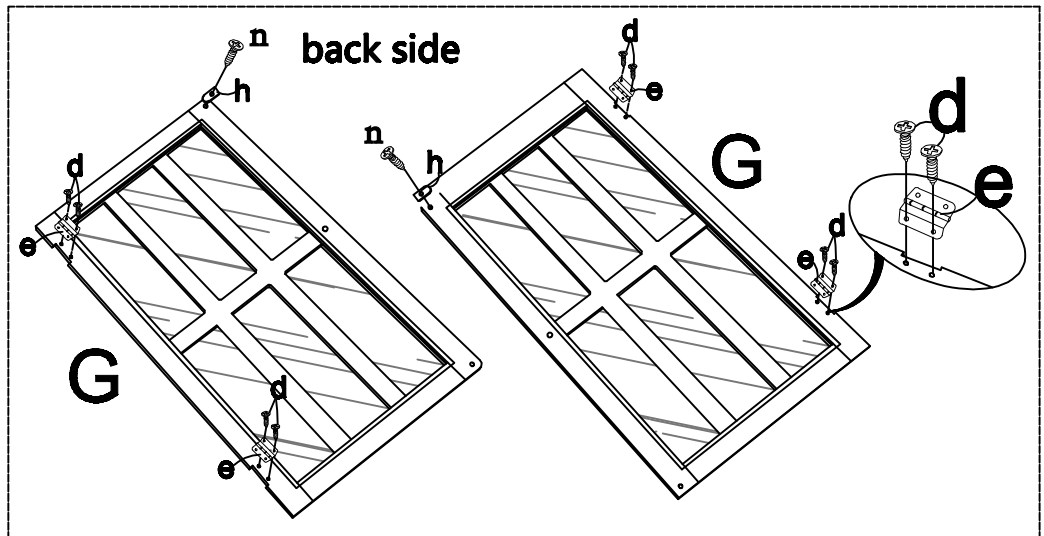
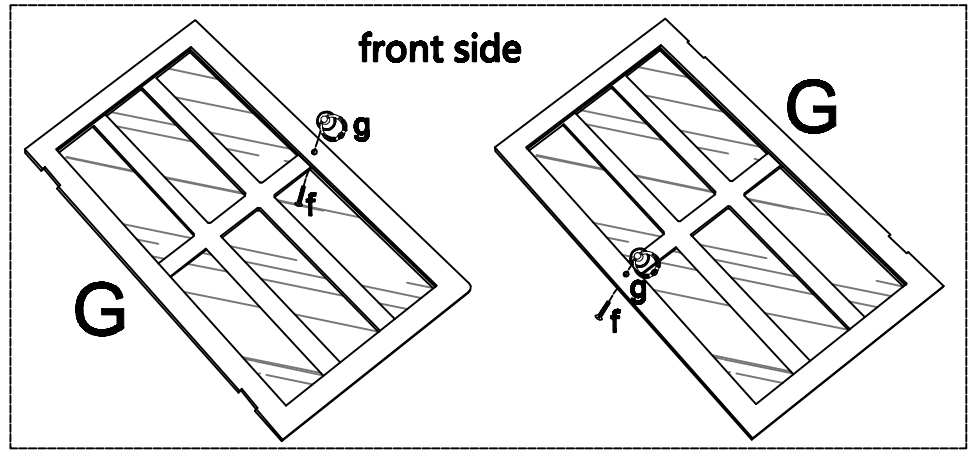

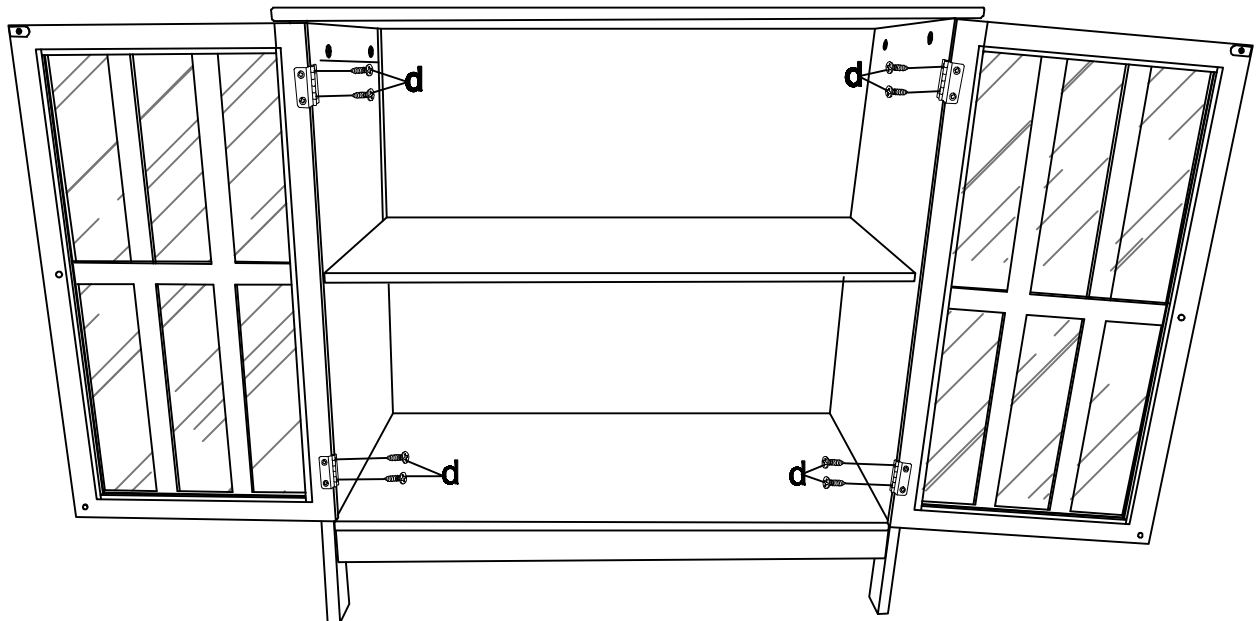

STEP 13

	d×8
---	------------





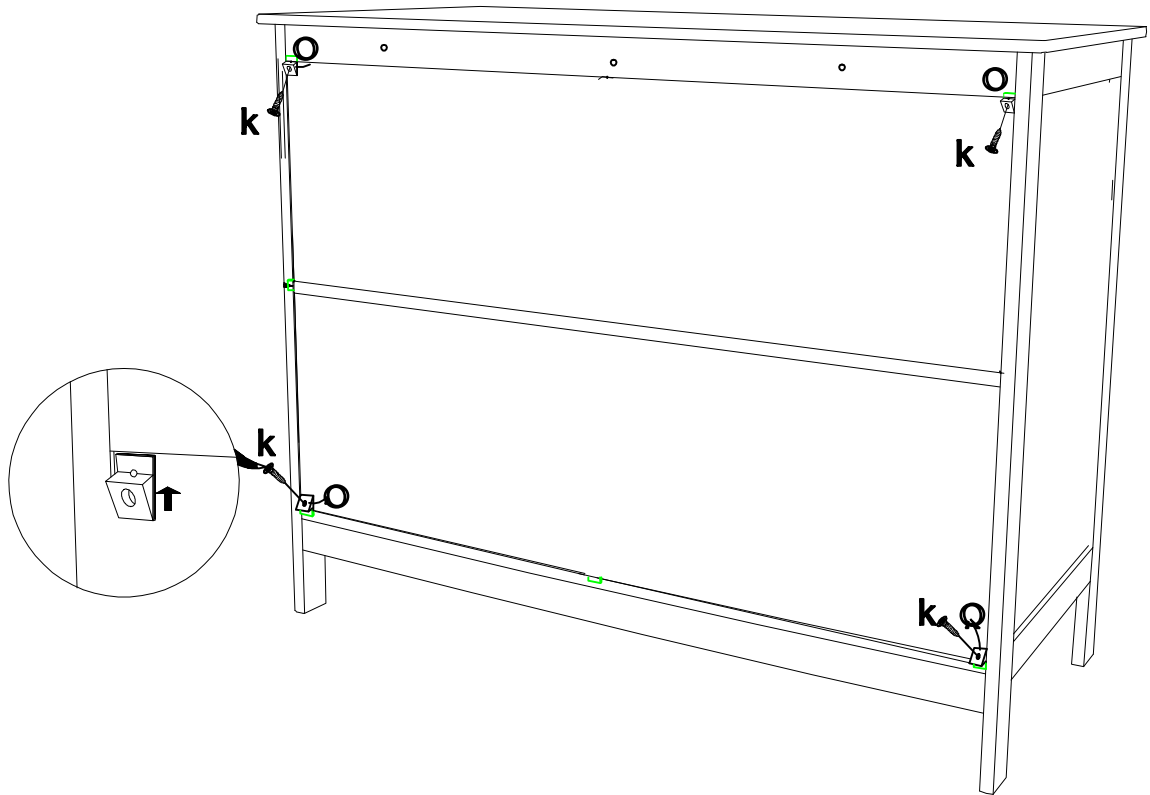

STEP 14

- | | | | |
|---|-----|---|-----|
|  | Ox4 |  | kx4 |
|---|-----|---|-----|



STEP 15

- | | | | | | | | | | |
|---|-------|---|-------|---|-------|--|-------|---|-------|
|  | d x 1 |  | l x 1 |  | m x 1 |  | j x 1 |  | p x 1 |
|---|-------|---|-------|---|-------|--|-------|---|-------|

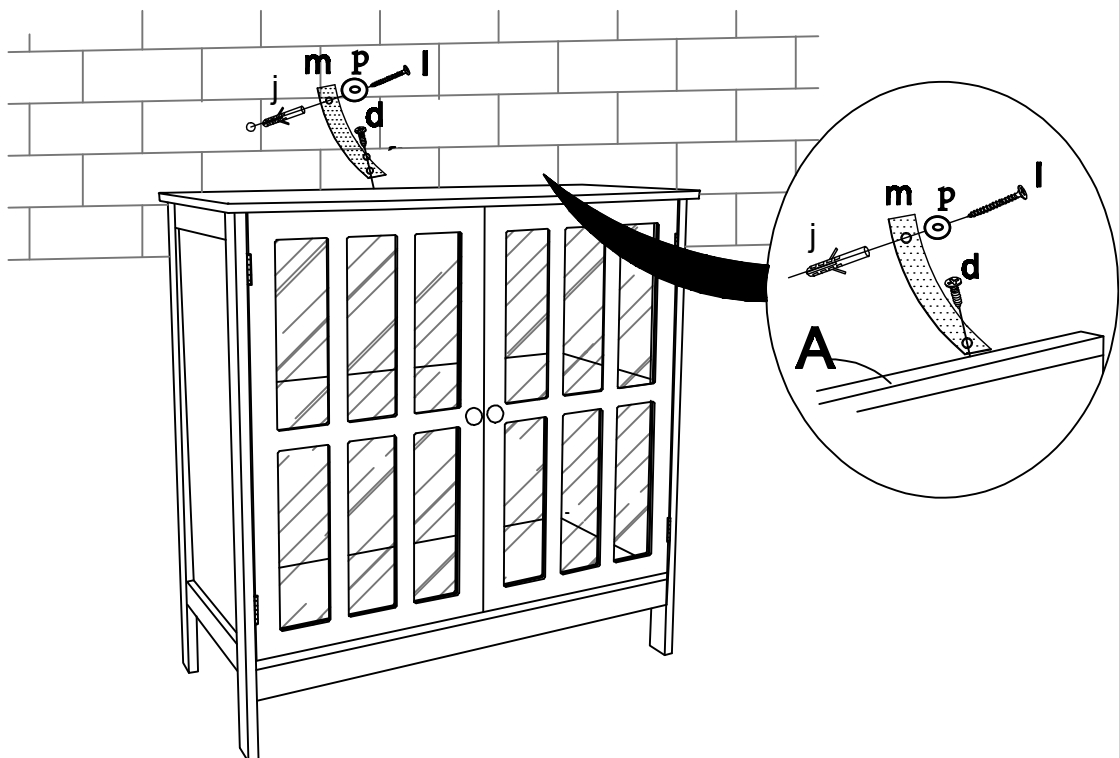

COMPLETE

