

SKU:SF001038

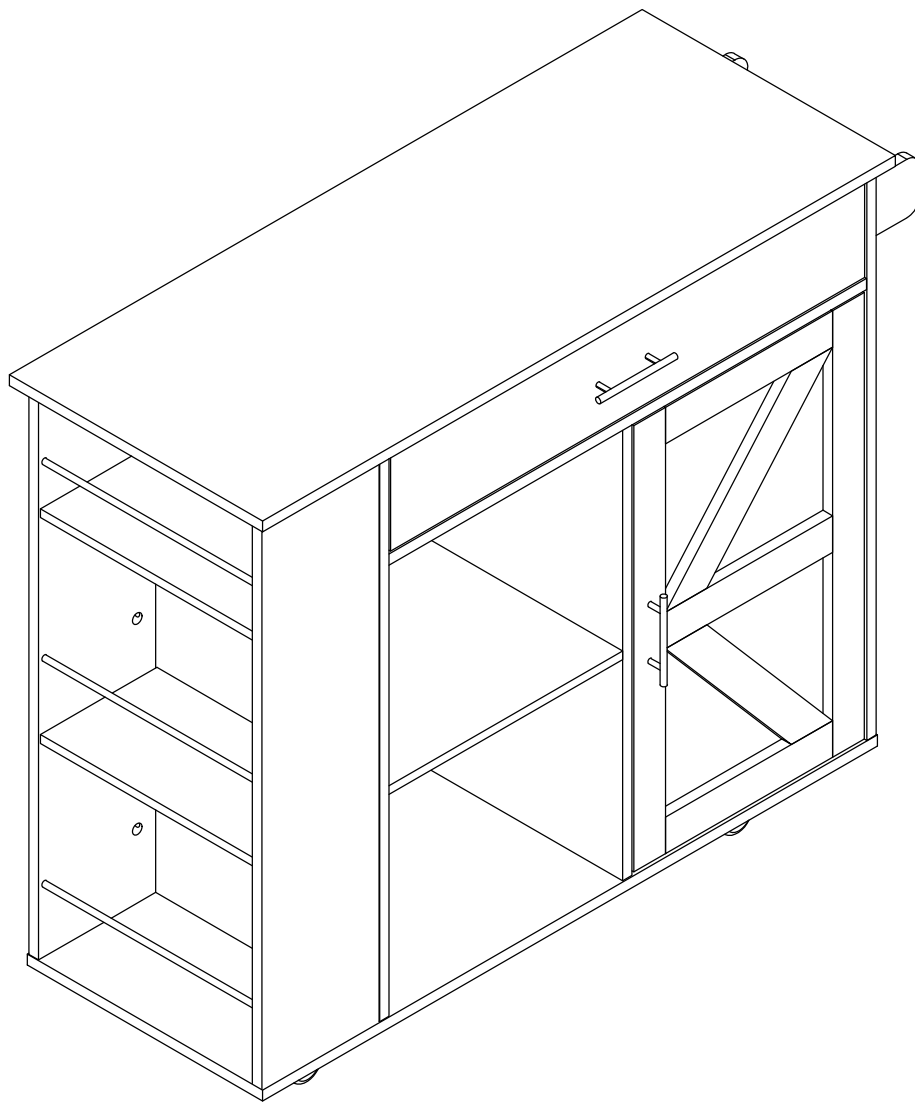

ASSEMBLY INSTRUCTIONS

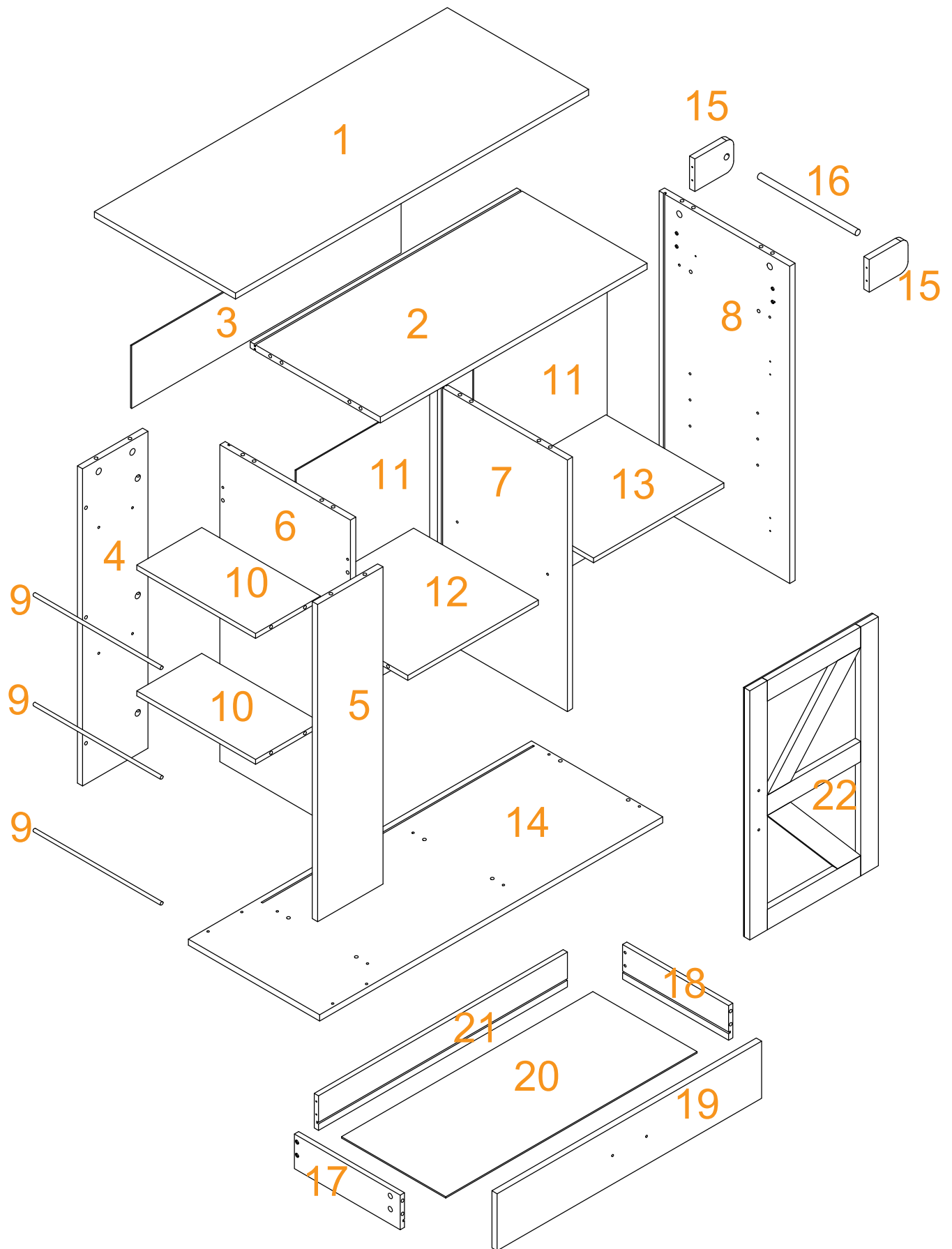

Before you install

- ✓ Classify and check all your parts and hardware
- ✓ Read each step carefully and follow the correct order
- ✓ Give yourself enough room for the assembly process

Caution: If using a power drill for screwing, please be aware to slowdown and stop when screw is tight.
Failure to do so may result in stripping the screw.

If moving the cabinet, please must be team lifted it instead drag. Failure to do so may result in leg drop.

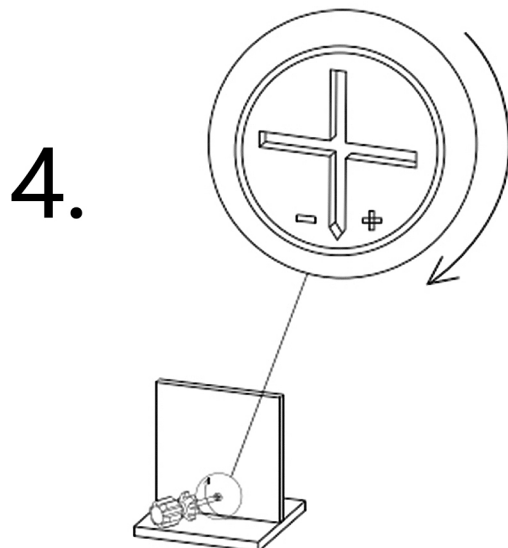
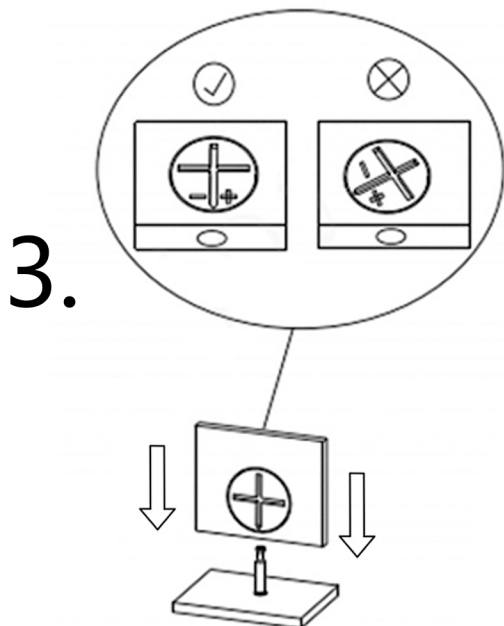
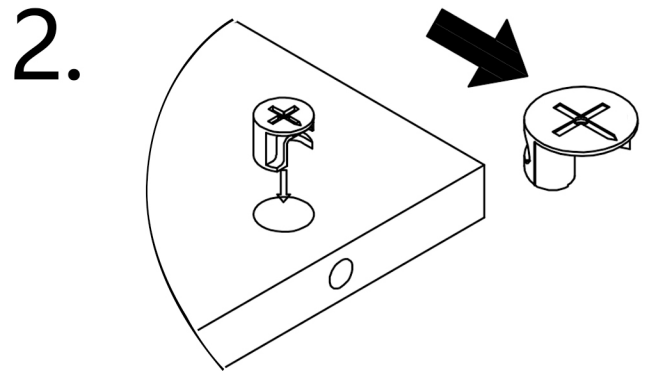
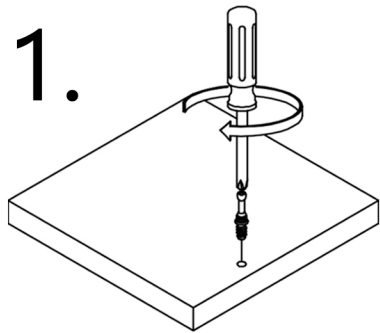

Parts List

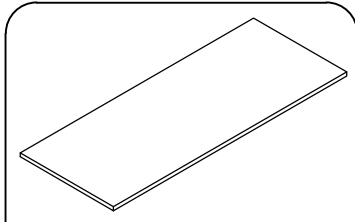

1

1PC

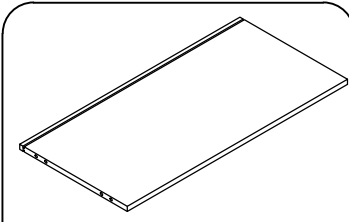

2

1PC

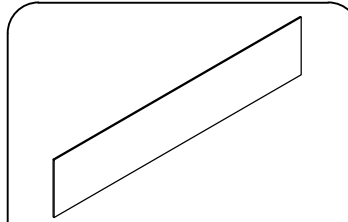

3

1PC

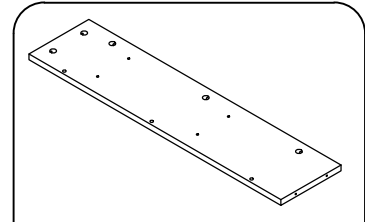

4

1PC

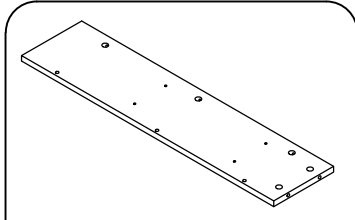

5

1PC

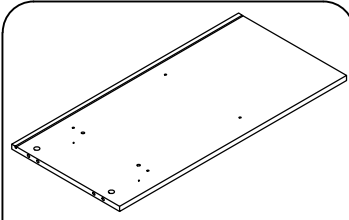

6

1PC

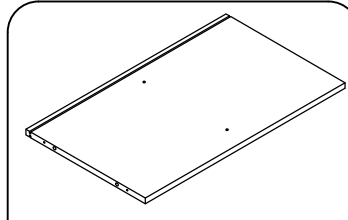

7

1PC

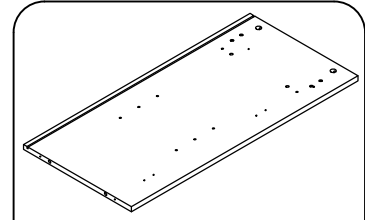

8

1PC

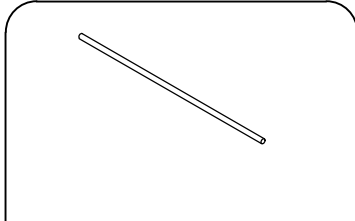

9

3PCS

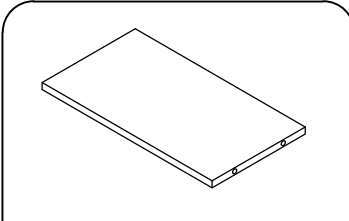

10

2PCS

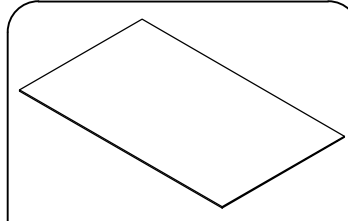

11

2PCS

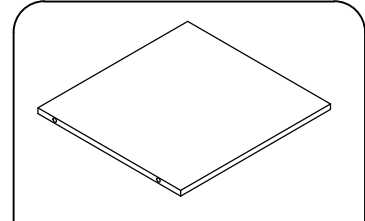

12

1PC

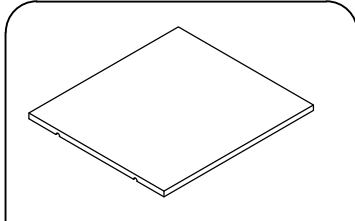

13

1PC

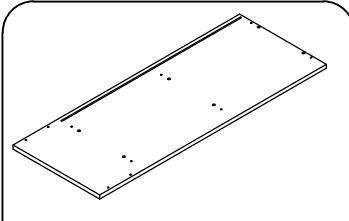

14

1PC

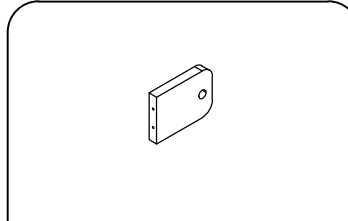

15

2PCS

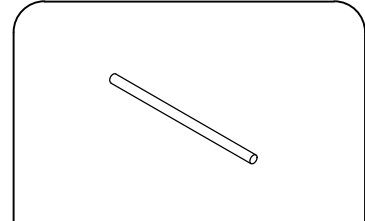

16

1PC

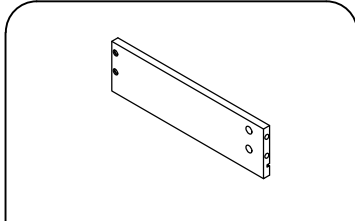

17

1PC

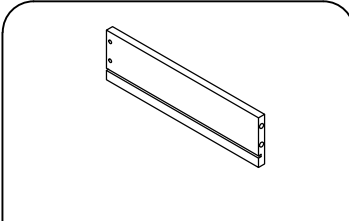

18

1PC

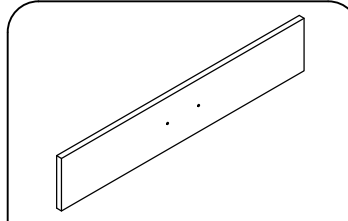

19

1PC

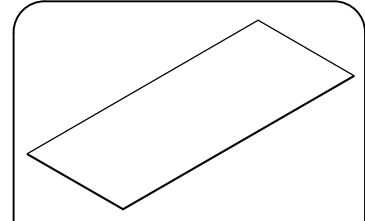

20

1PC

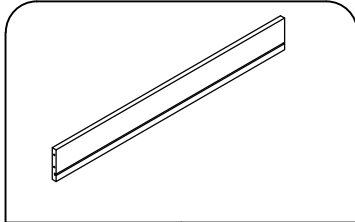

21

1PC

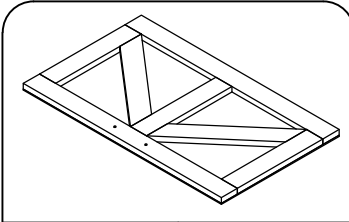

22

1PC

Hardware List

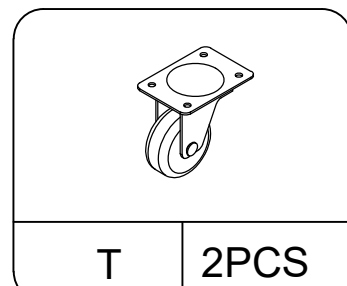
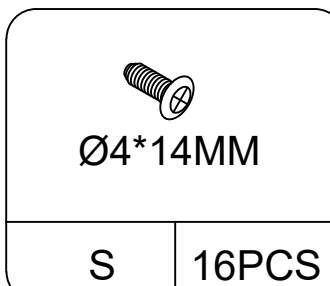
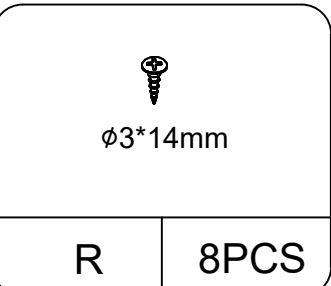
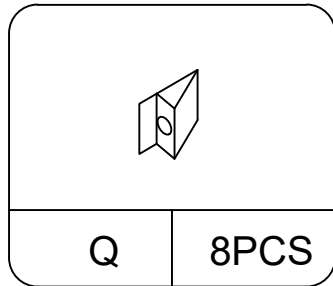
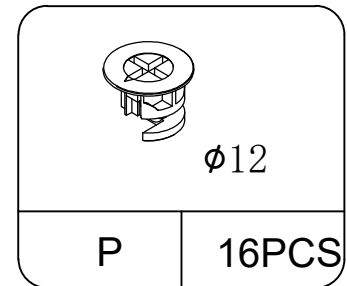
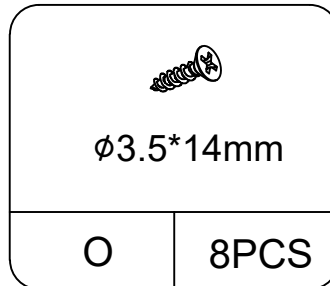
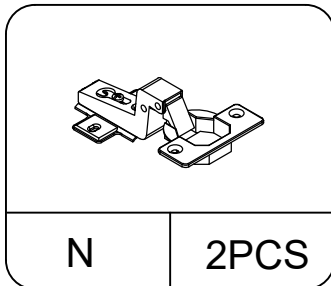
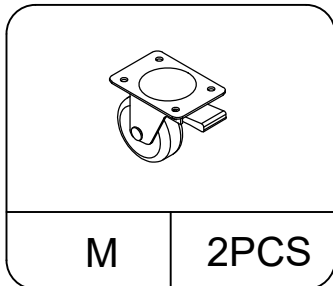
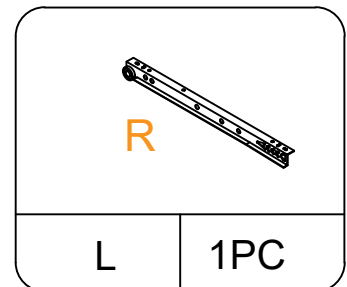
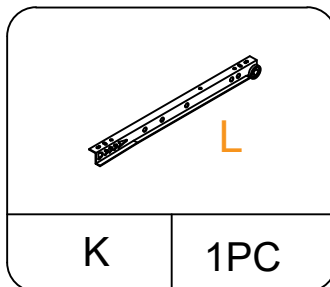
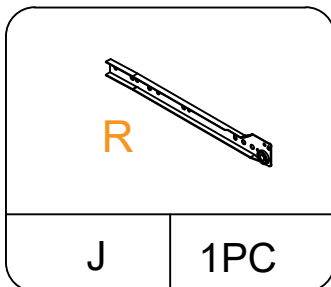
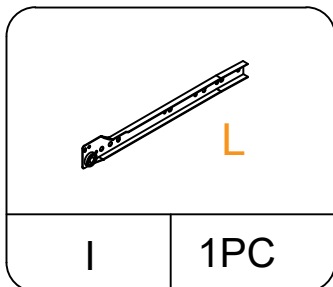
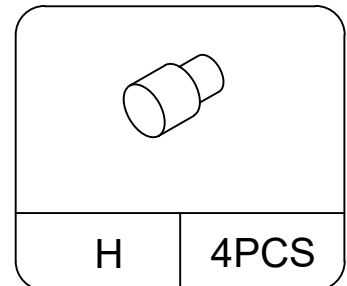
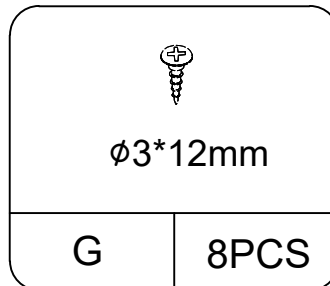
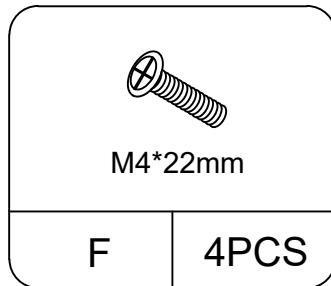
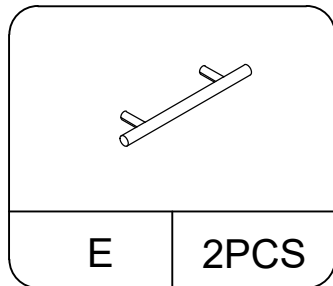
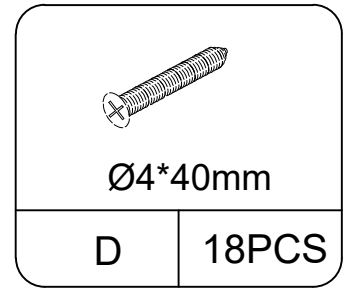
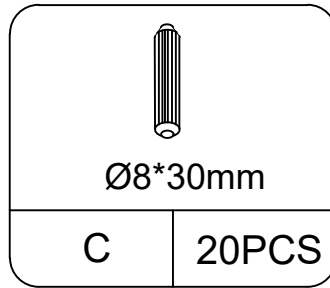
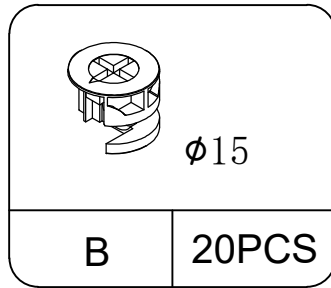
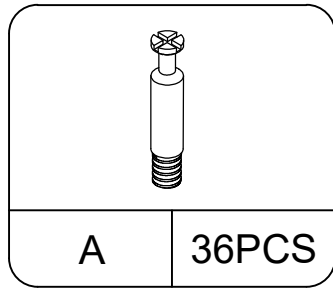

STEP 1

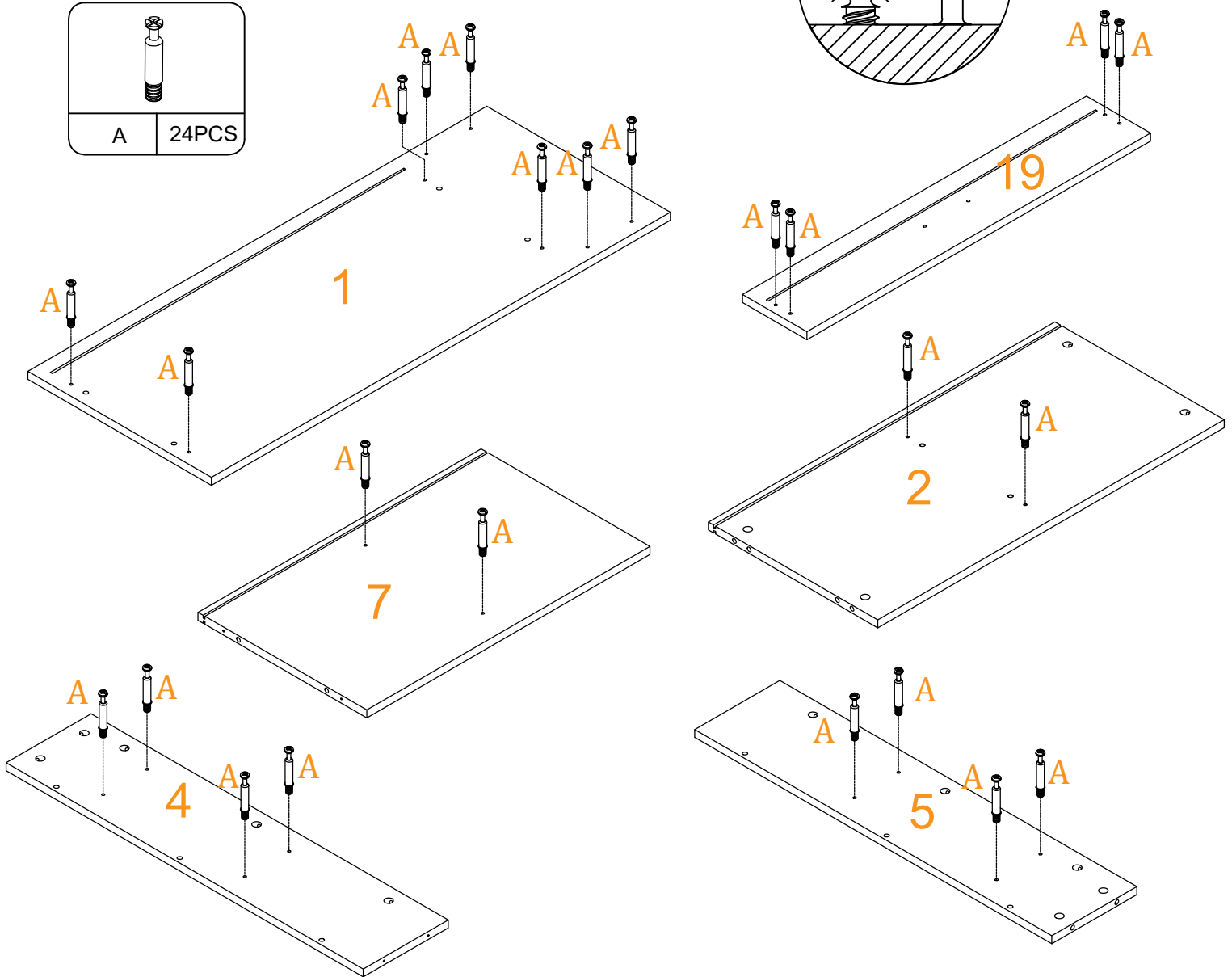
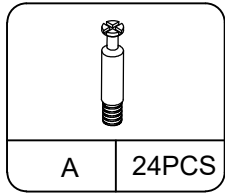

STEP 2

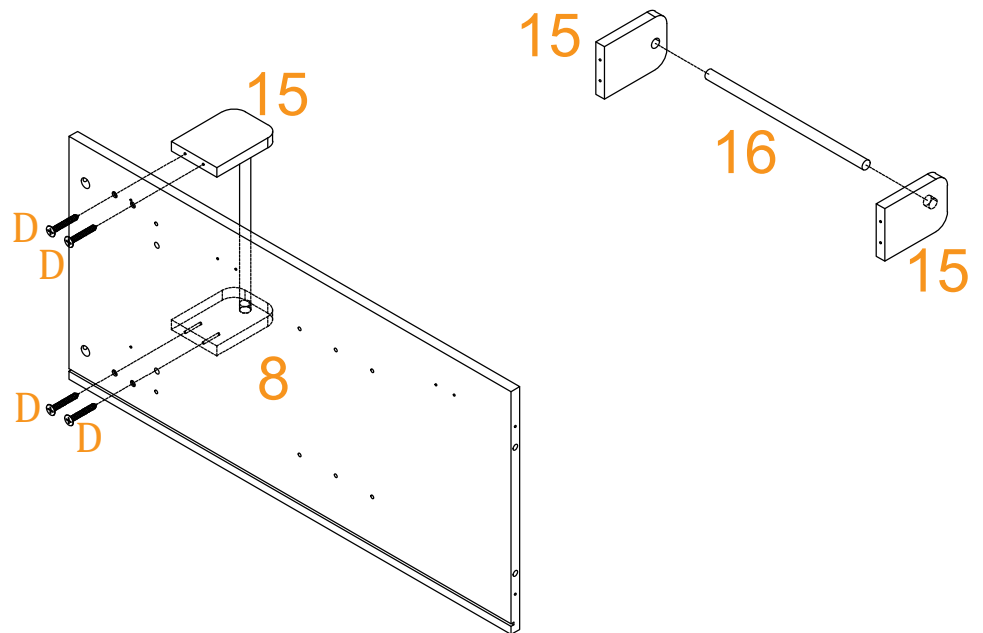
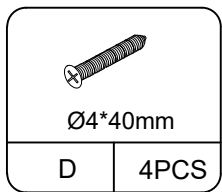

STEP 3

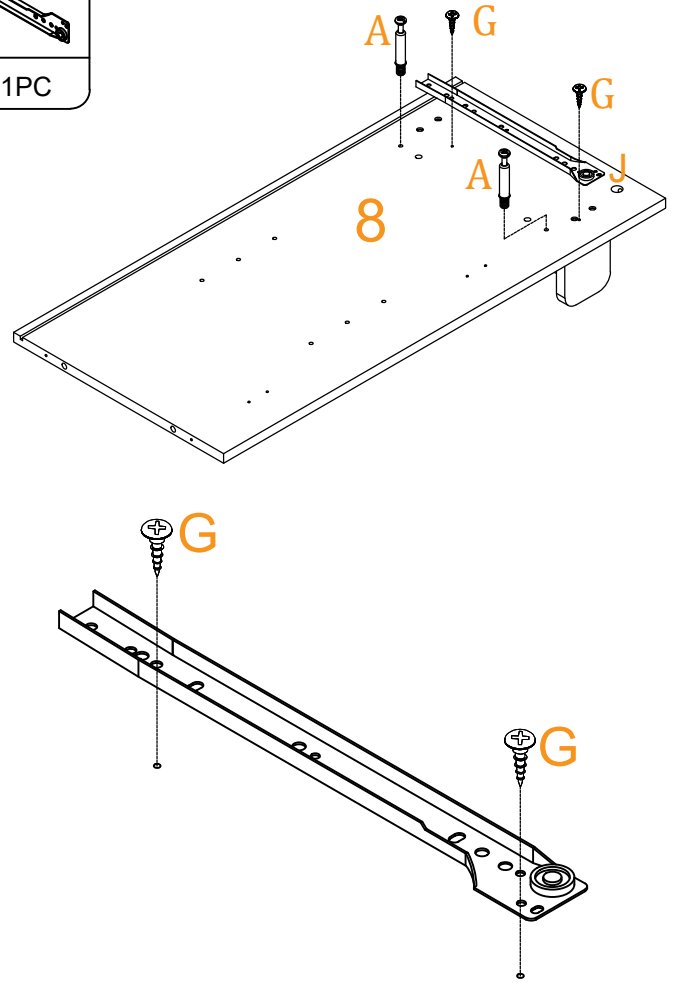
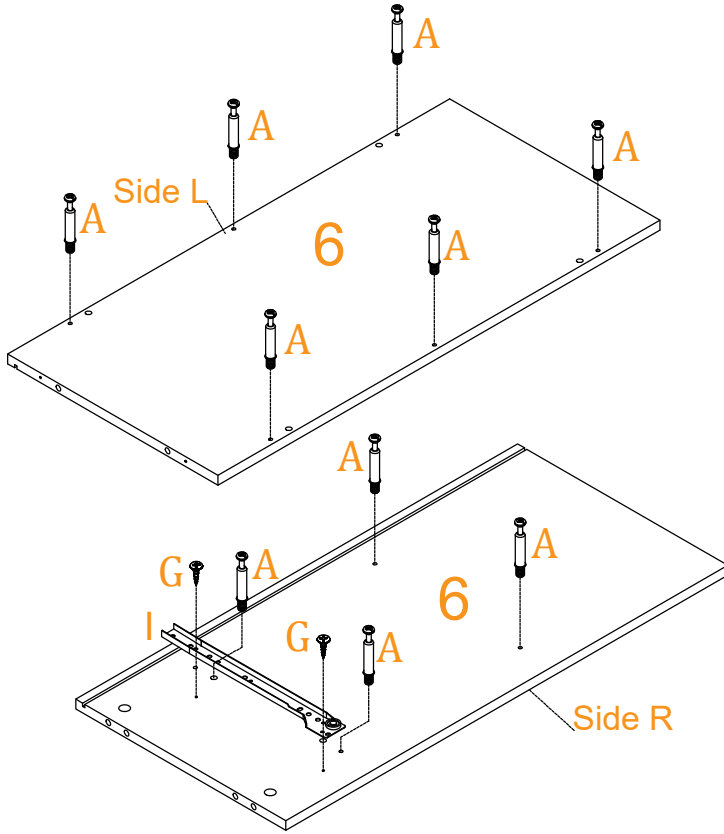
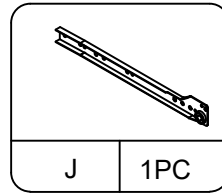
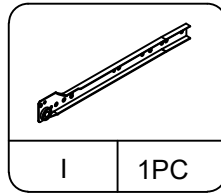
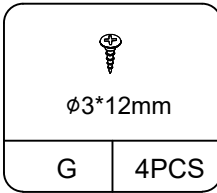
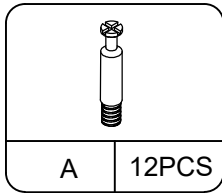

STEP 4

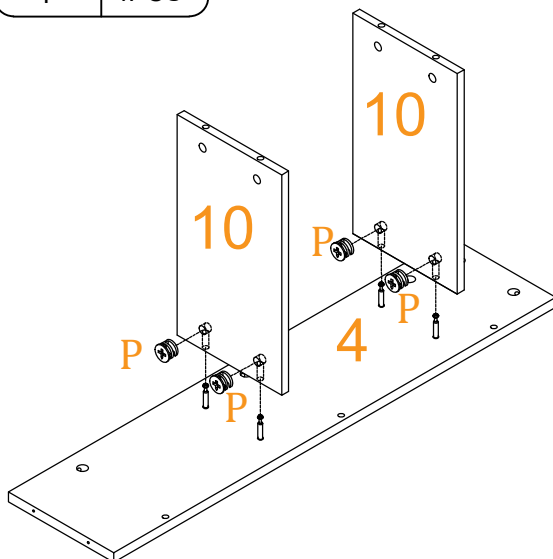
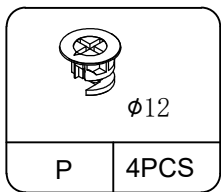

STEP 5

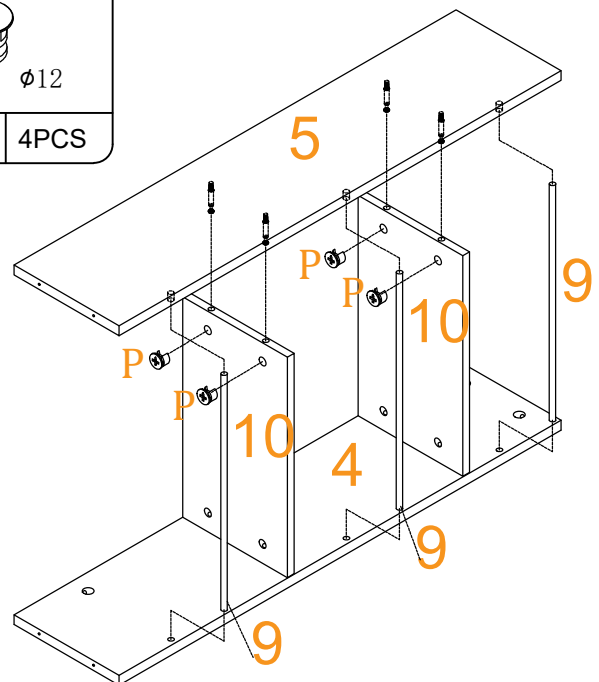
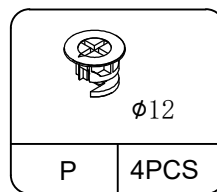

STEP 6

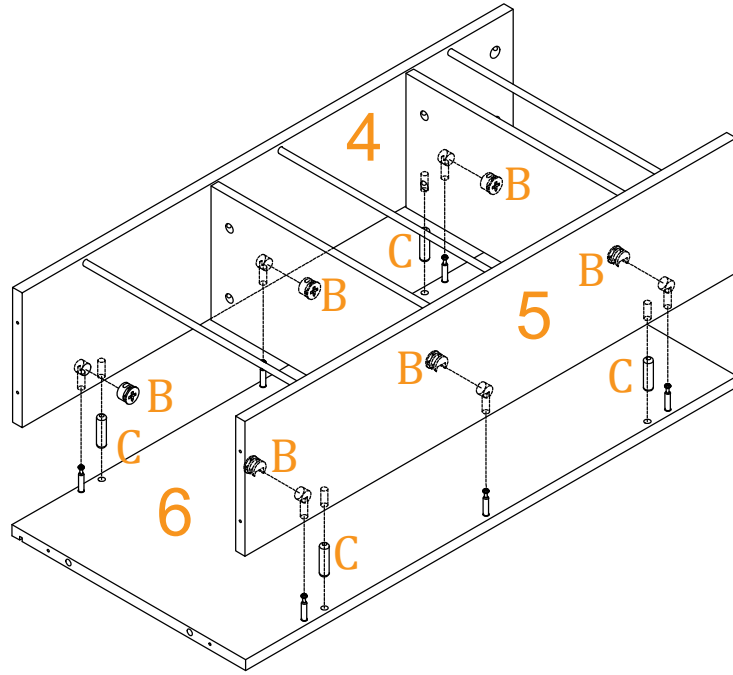
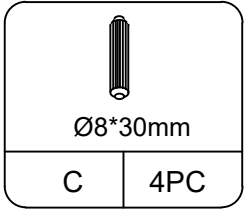
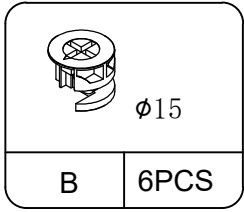

STEP 7

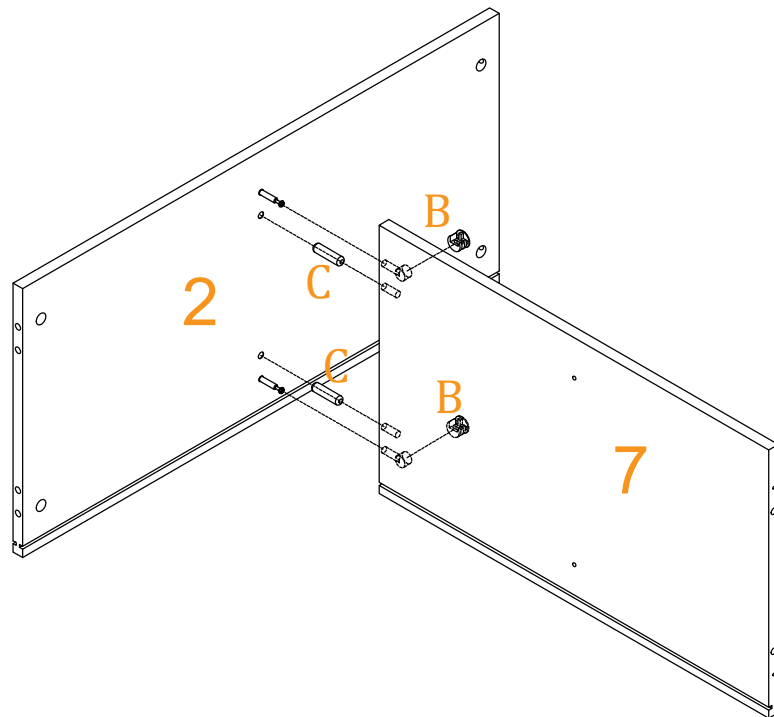
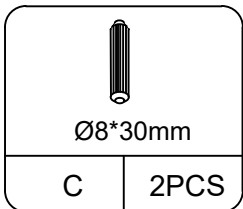
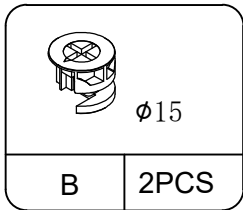

STEP 8

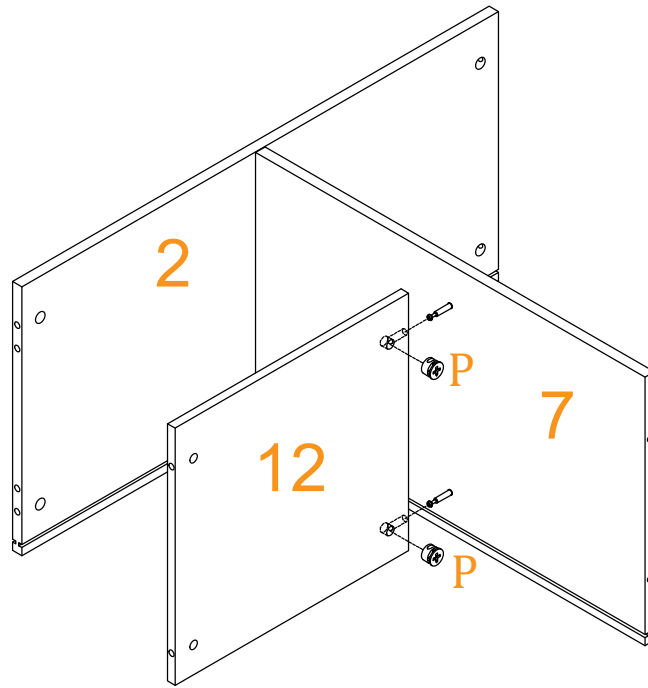
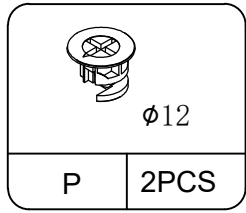

STEP 9

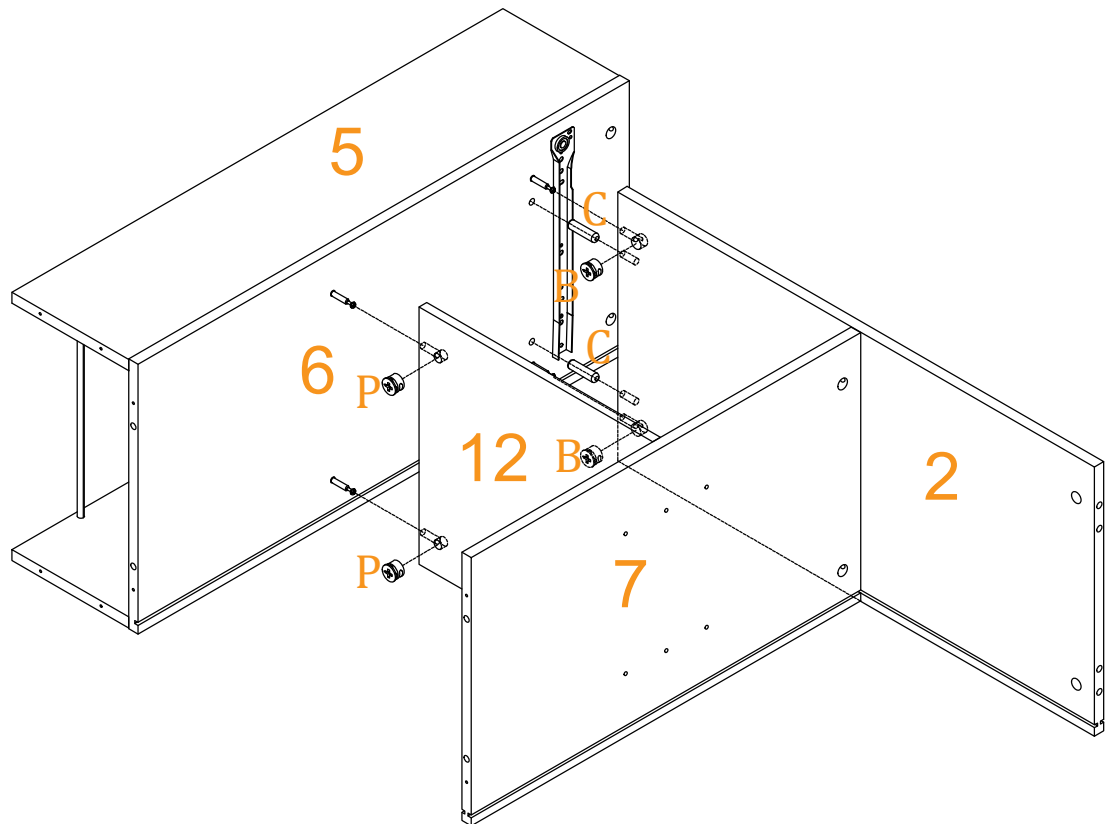
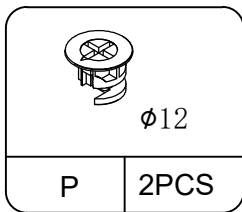
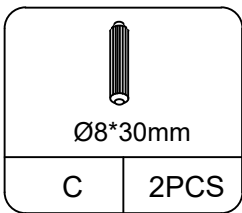
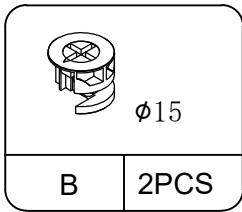

STEP 10

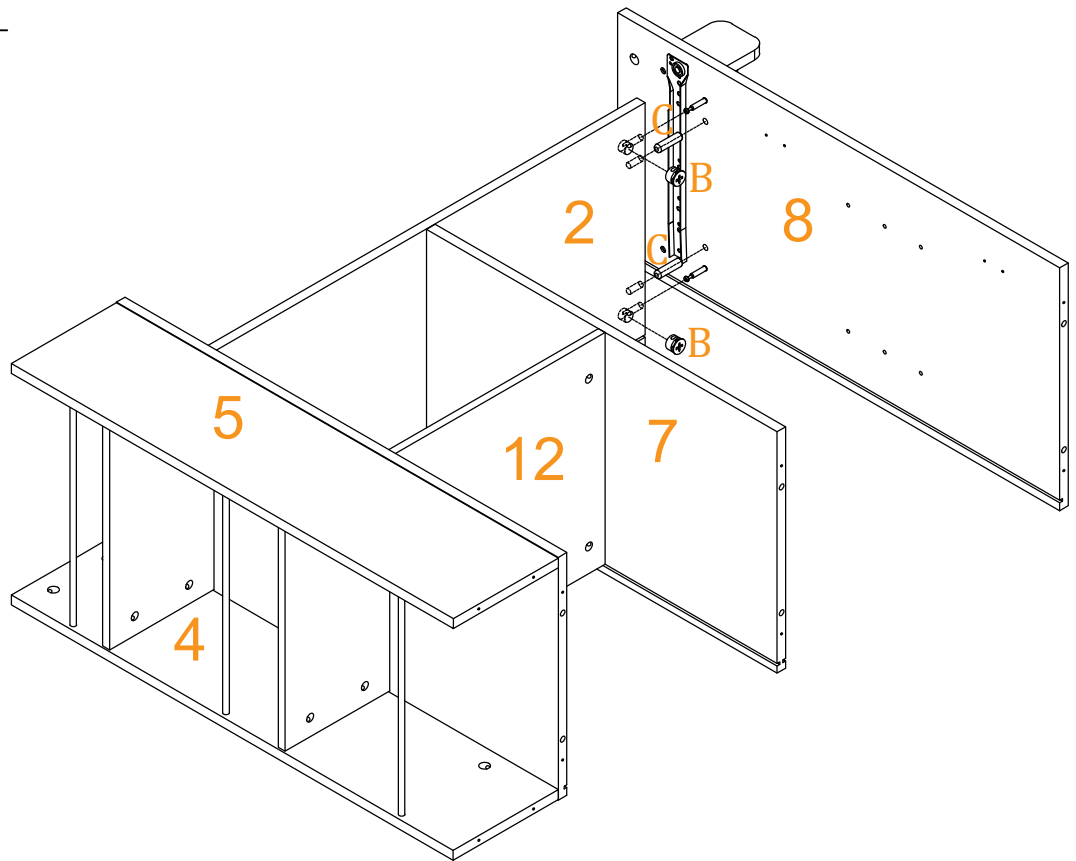
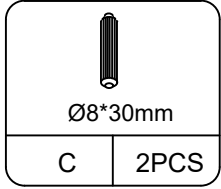
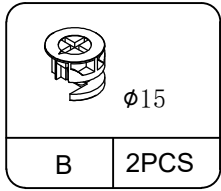

STEP 11

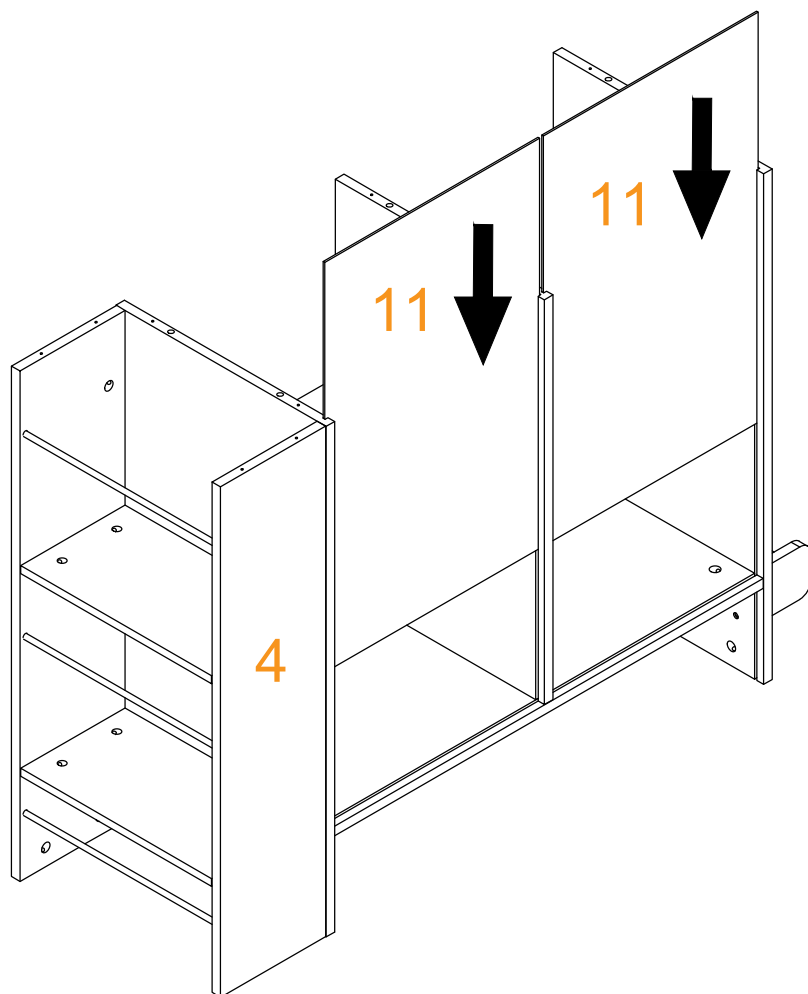

STEP 12

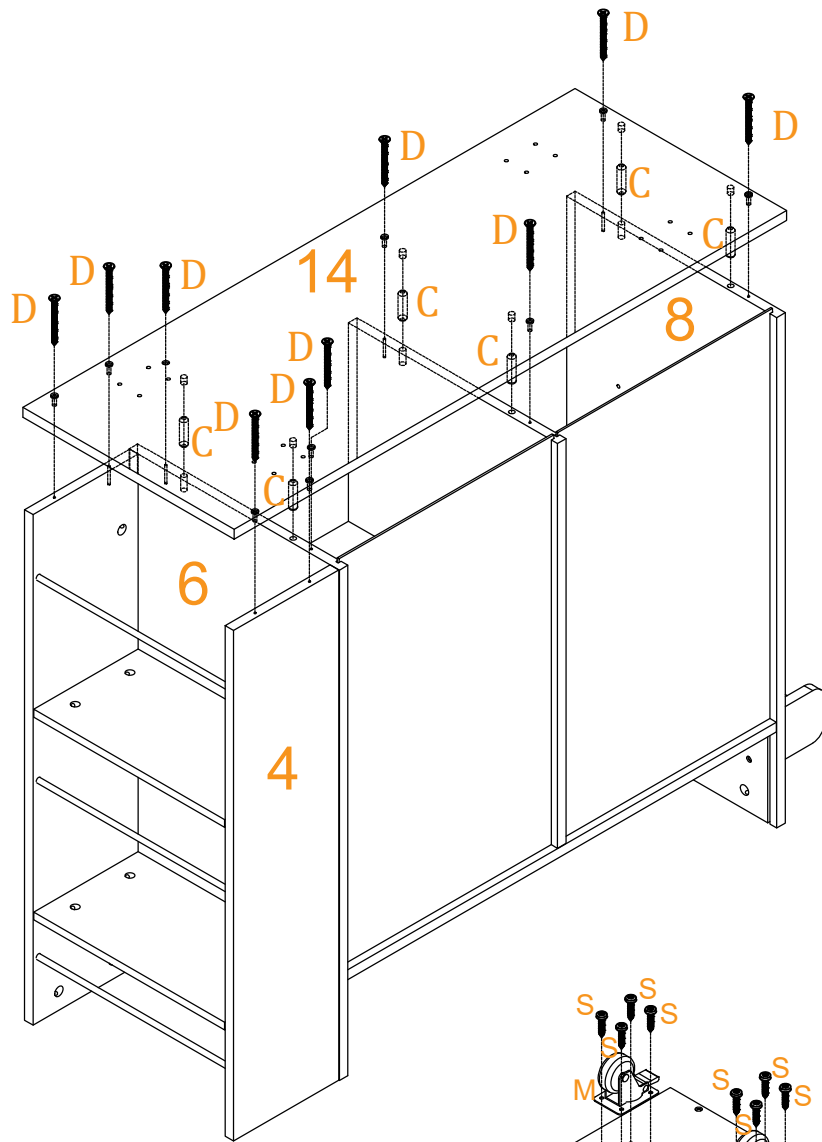
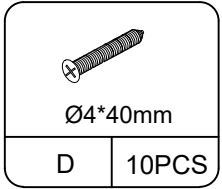
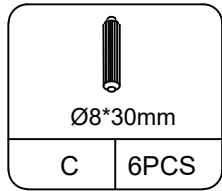

STEP 13

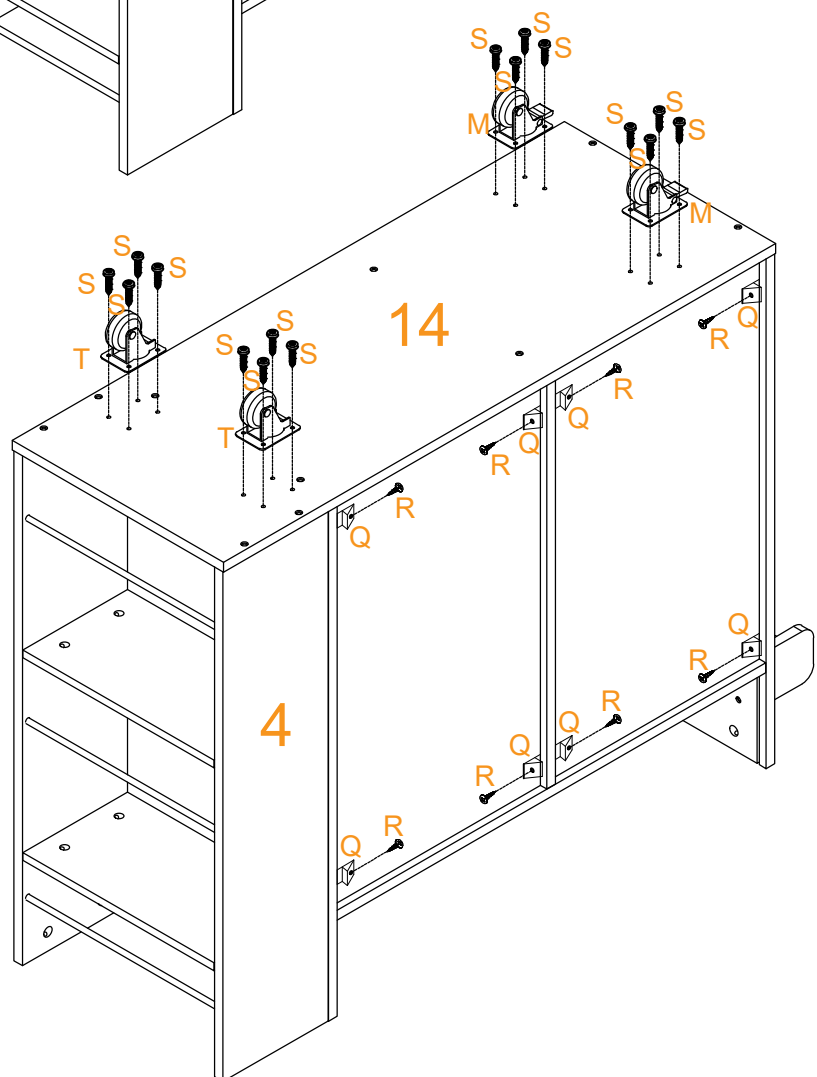
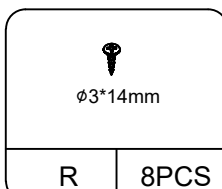
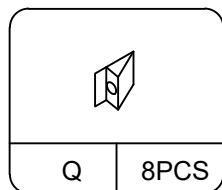
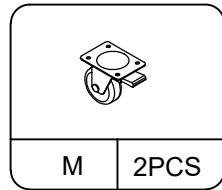
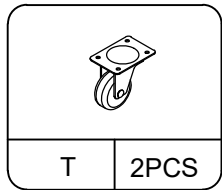
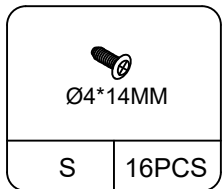

STEP 14

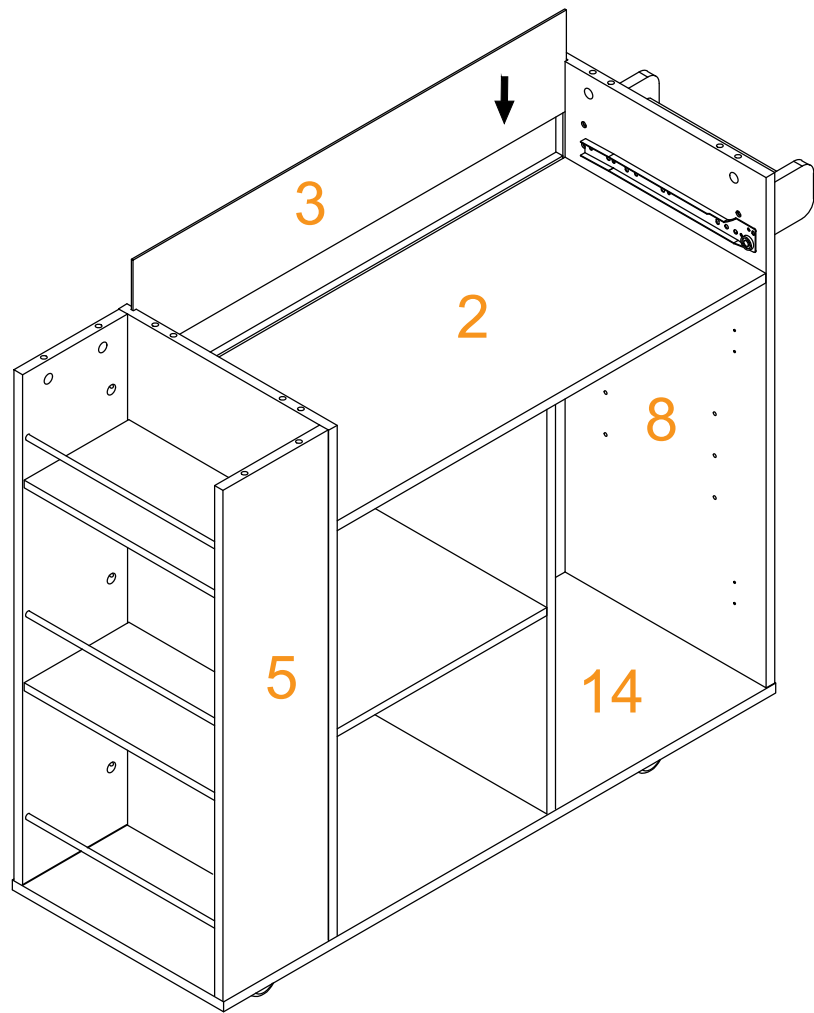

STEP 15

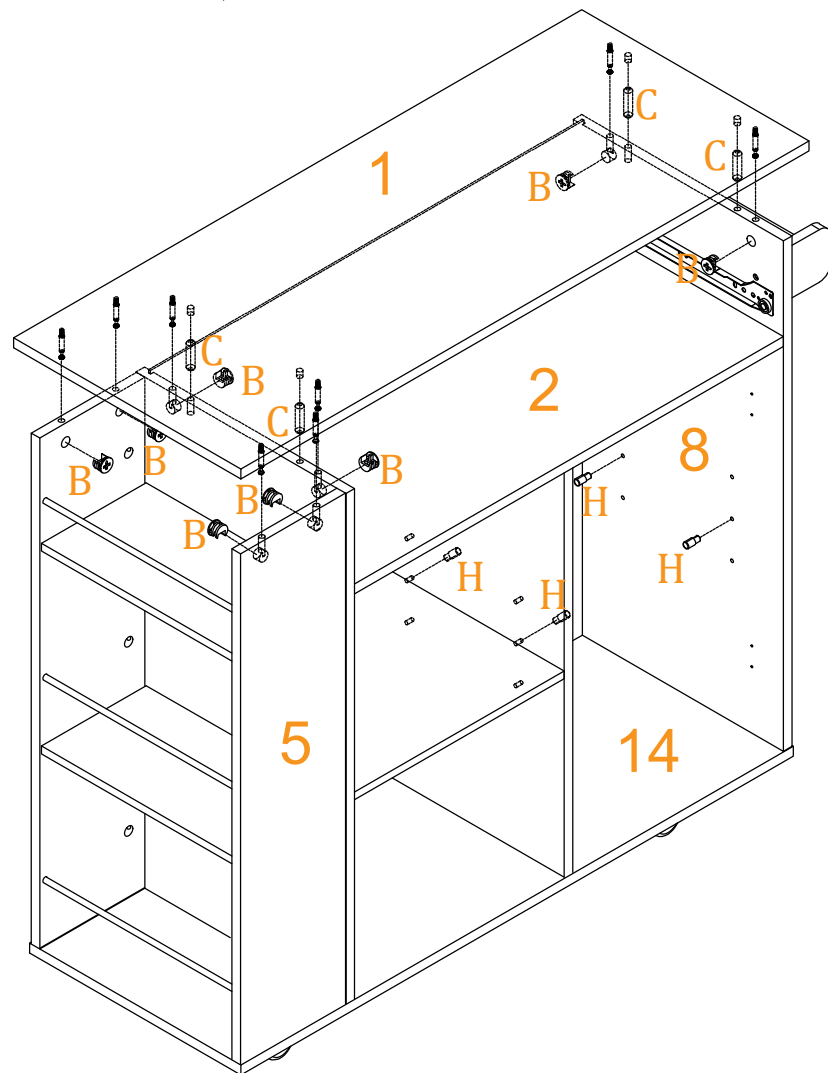
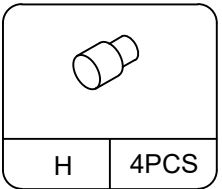
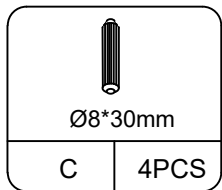
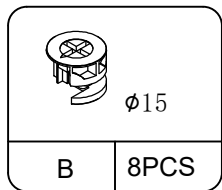

STEP 16

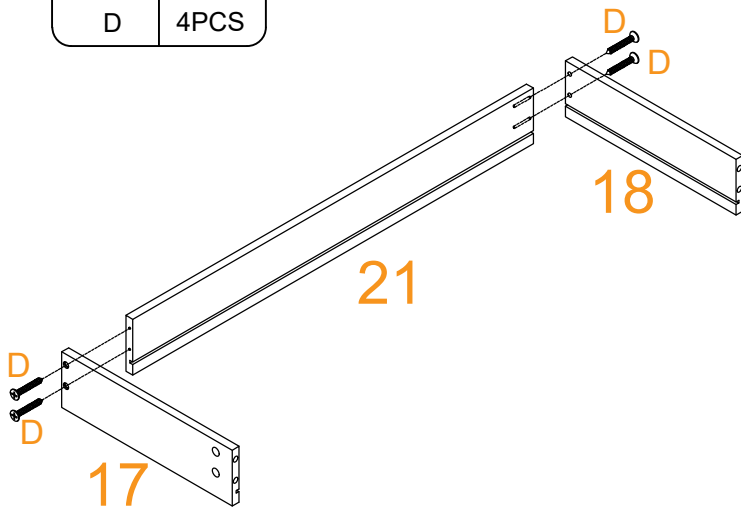
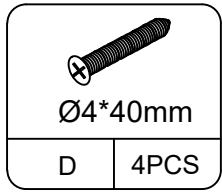

STEP 17

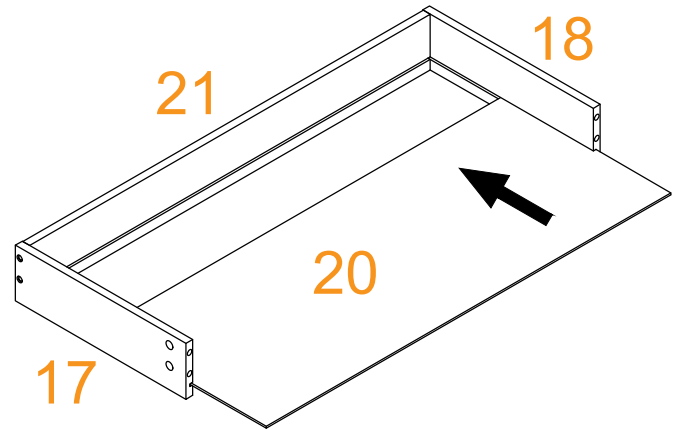

STEP 18

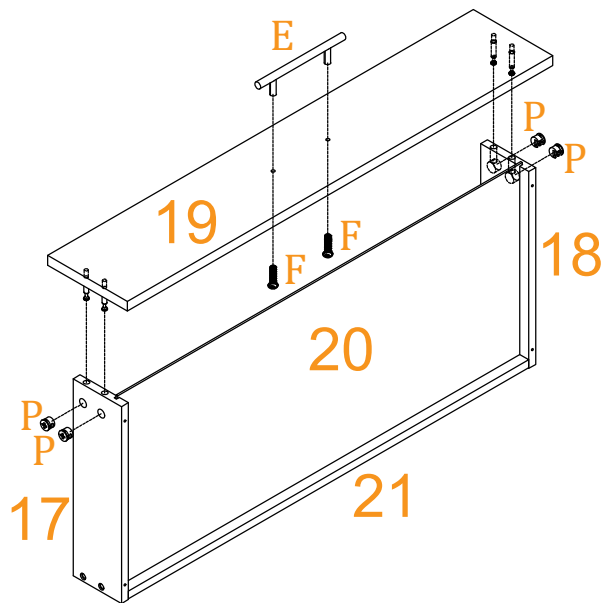
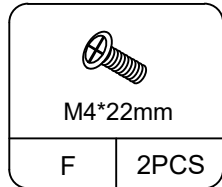
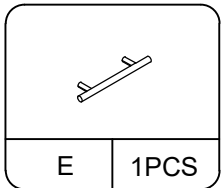
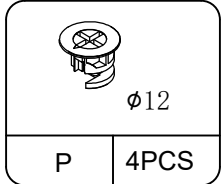

STEP 19

Ø3x12mm	
G	4PCS

K	1PCS

L	1PCS

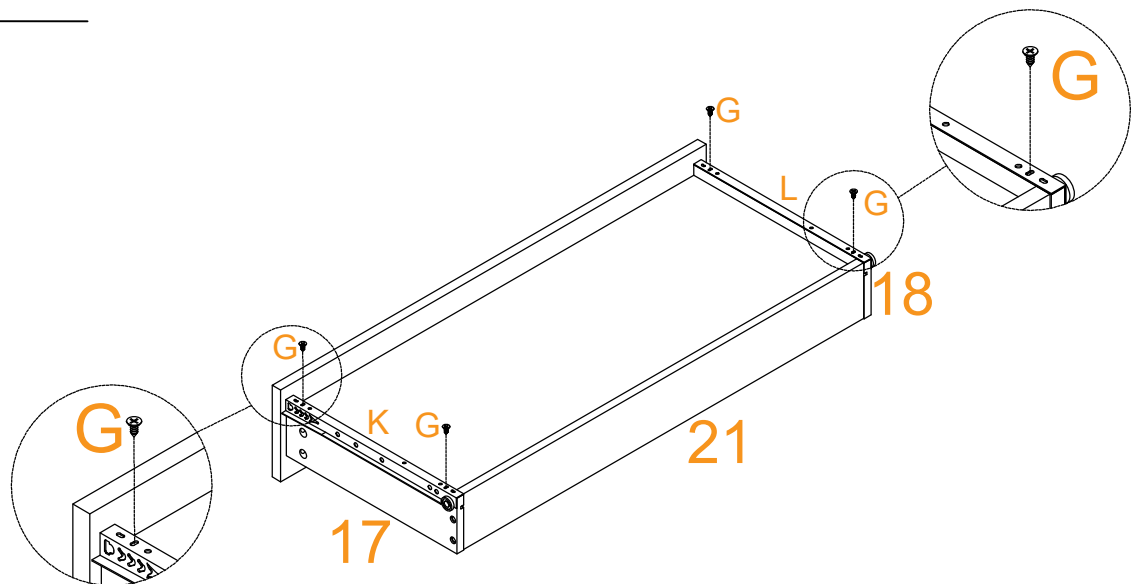

STEP 20

Ø3.5*14mm	
O	4PC

N	2PC

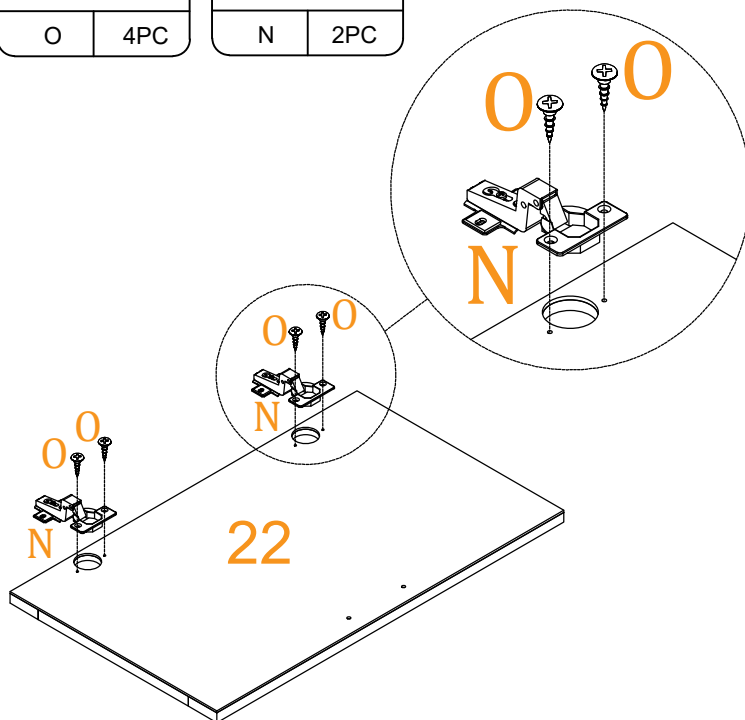

STEP 21

M4*22mm	
F	2PC

E	1PC

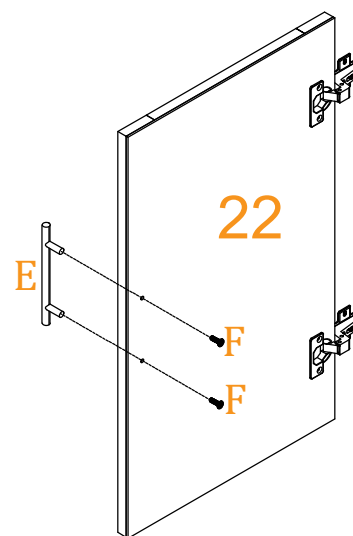

STEP 22

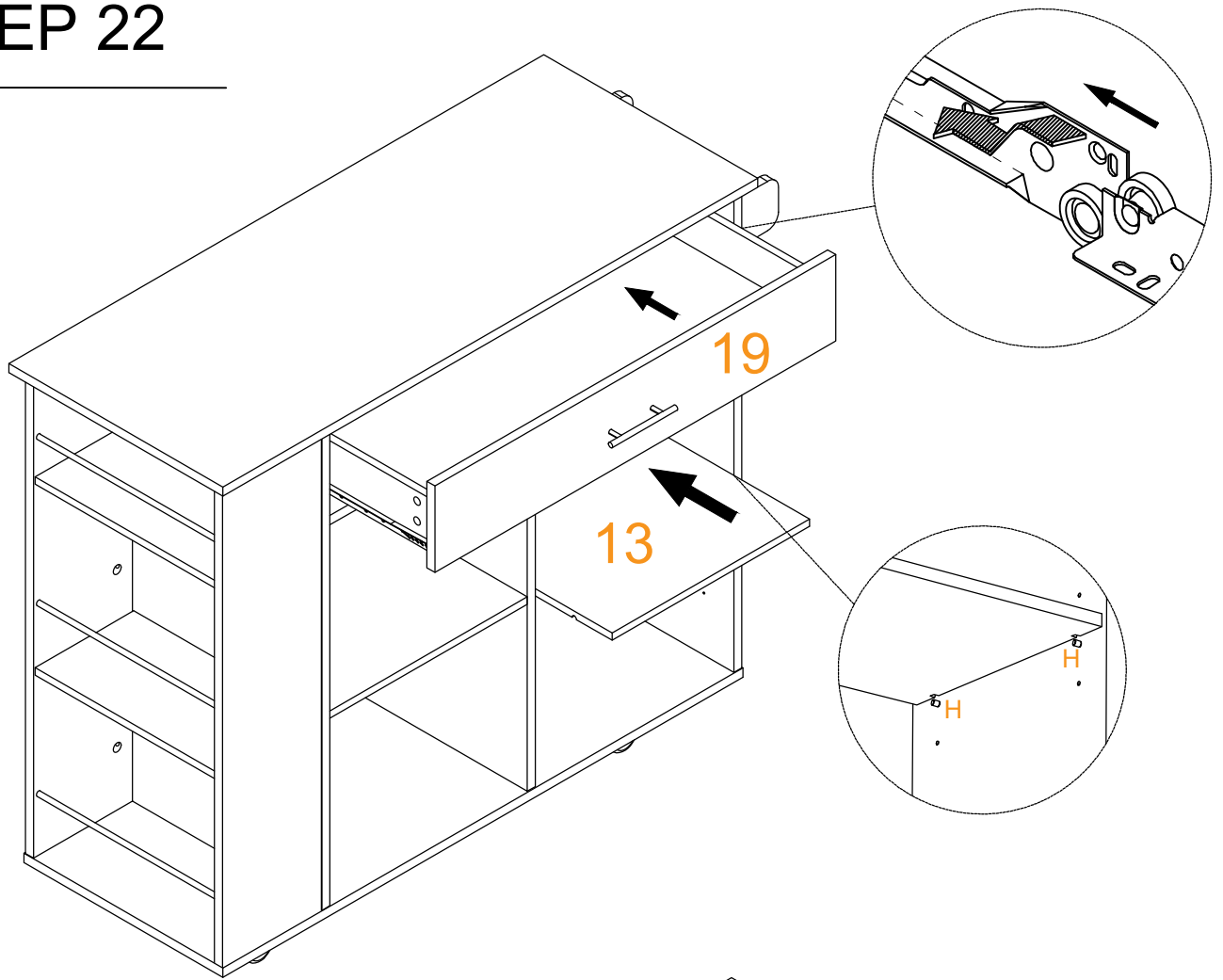

STEP 23

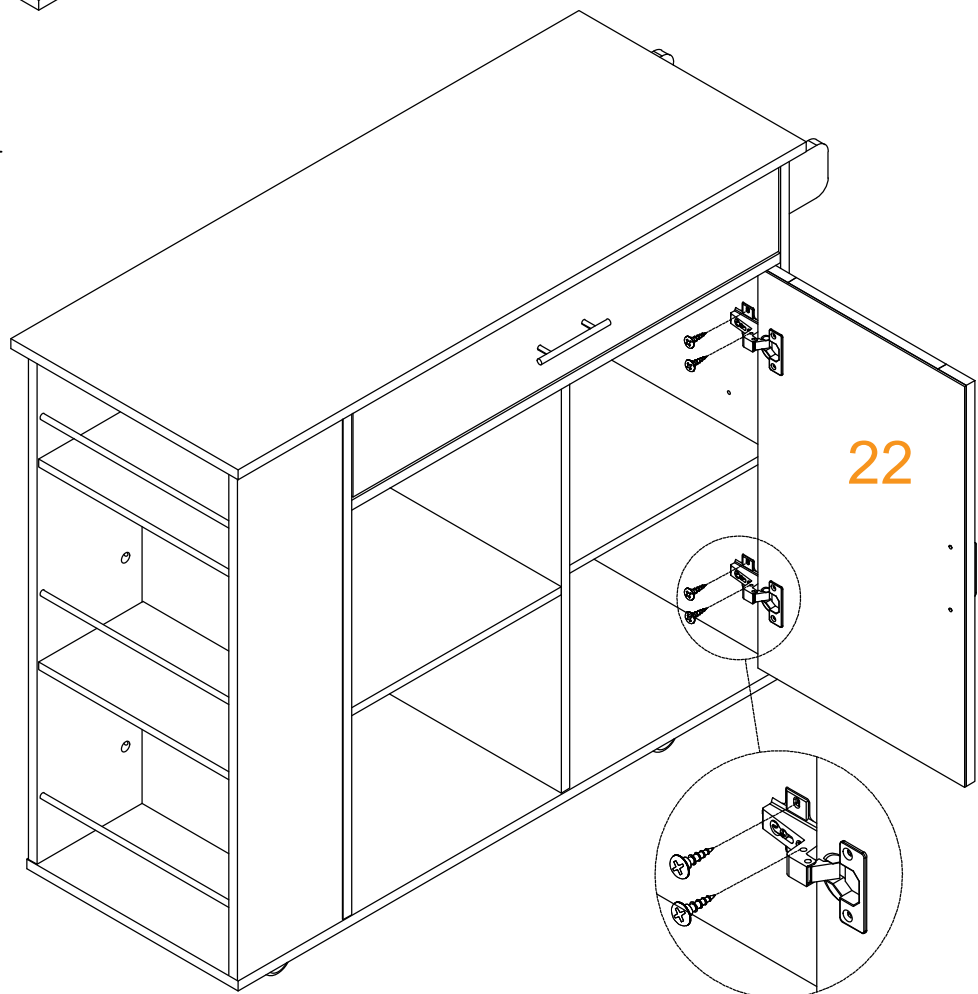
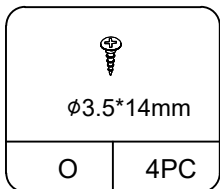

Door Hinge Adjustment Instructions

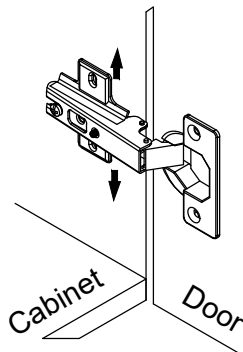
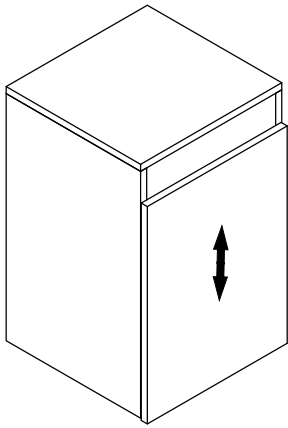
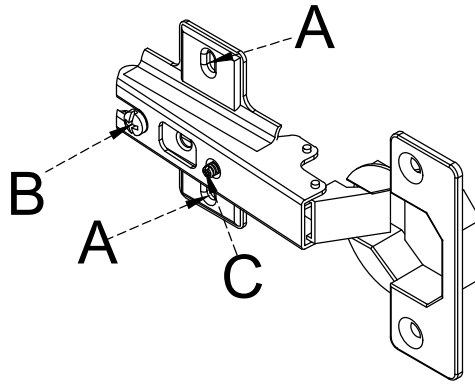

To adjust the vertical height.

Loosen the two screws "A" on hinges, Usually in slotted holes which allows you to adjust up or down by a few mm Then tighten back .

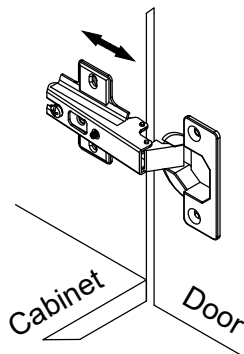
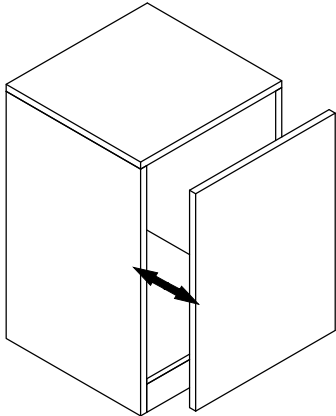

To adjust depth.

Loosen screw "B" and adjust door, if the door can not be adjusted, please loosen screw "C", then try again. Tighten screw "B" and "C"

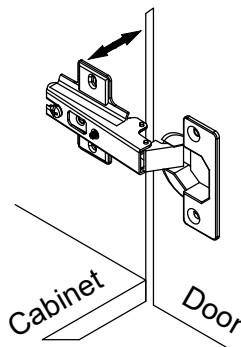
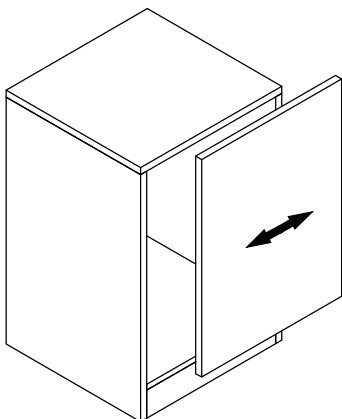

To adjust side ways.

Turning the screw "C" on BOTH hinges on each door.