

Installation Manual



Vertical Storage Shed

Thanks to choose our product. Missing parts, Quality, Installation Questions, please contact with us.

Model : CWX120B

Tools you need:

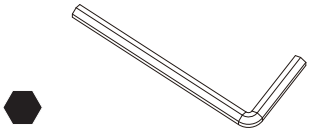

Hex wrench
(included in the box)

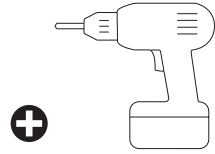

Electric drill
(Not included in the accessory pack)

Notes:

1. Before you start, separate and identify all the parts and plates to be sure that you have all the necessary parts for your building (refer to the Components List Page).
2. Finding a necessary area to assemble the storage shed, make sure the floor is flat.
3. Reviewing all instructions and the appropriate information before you begin, make sure following the step sequence carefully for successful results.
4. Following the steps to open the parts' bags and do not open all the bags in one time in case of mixture of parts.
5. The company will not be responsible for any losses caused by parts' damage due to incorrect installation methods, and the customer shall bear the responsibility on their own.

Position of codes on plates:

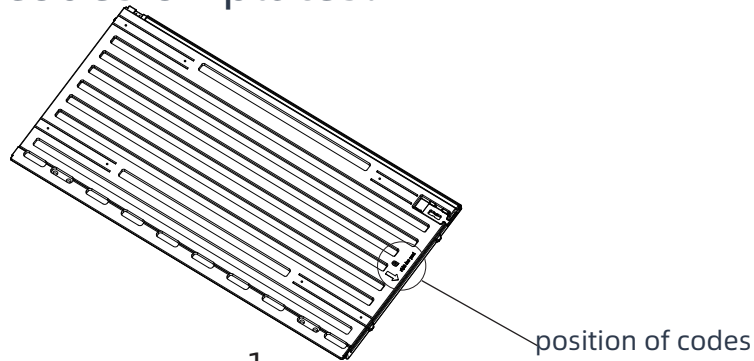



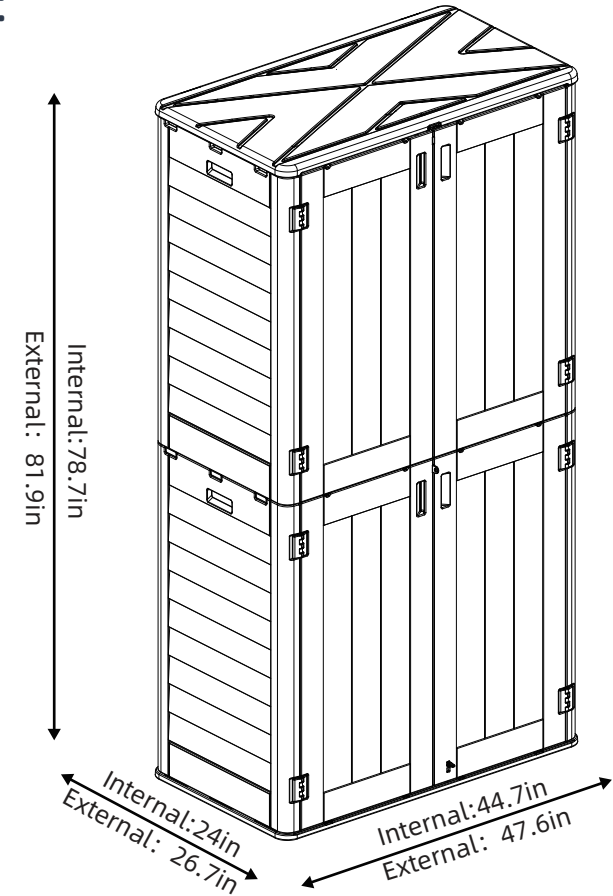







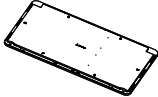
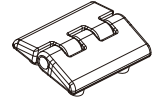

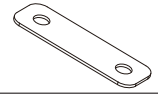
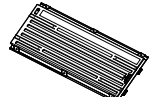
Sizes:

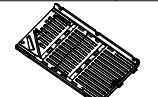

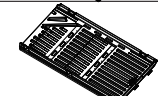
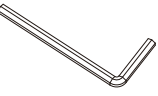
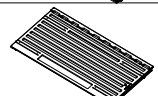
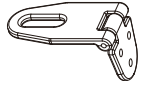
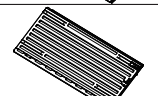

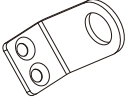

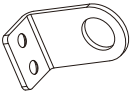

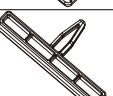
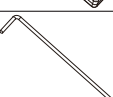

Area of installation requirement

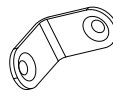

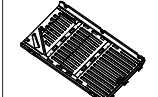
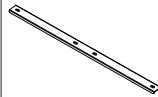
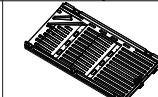
Components List-A

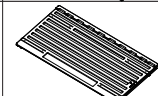
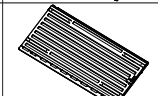
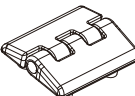
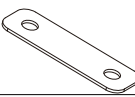
Code	Photo	Qty	Position Of Package	Code	Photo	Qty	Position Of Package
A		1	Carton No.A	M		6	A-1
B		1	Carton No.A	N		12	A-1
C		1	Carton No.A	O		24	A-1
D		1	Carton No.A	P		9	A-2
E		1	Carton No.A	Q		1	A-2
F		1	Carton No.A	R		1	A-3
G		1	Carton No.A	S		3	A-3
H		1	Carton No.A	T		1	A-6
I		1	A-5	U		1	A-6
J		1	A-4	S		4	A-6
K		1	A-4		Backup	1	
L		1	A-5				

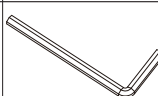
Components List-B

Code	Photo	Qty	Position Of Package	Code	Photo	Qty	Position Of Package
B		1	Carton No.B	W		2	B-4
C		1	Carton No.B	S		4	B-4
D		1	Carton No.B	X		12	B-5
E		1	Carton No.B	O		48	B-5
F		1	Carton No.B		Backup	1	
G		1	Carton No.B				
M		4	B-1				
N		8	B-1				
O		16	B-1				
P		9	B-2				
Q		1	B-2				
V		4	B-3				

Top1

MIDDLE&UNDER

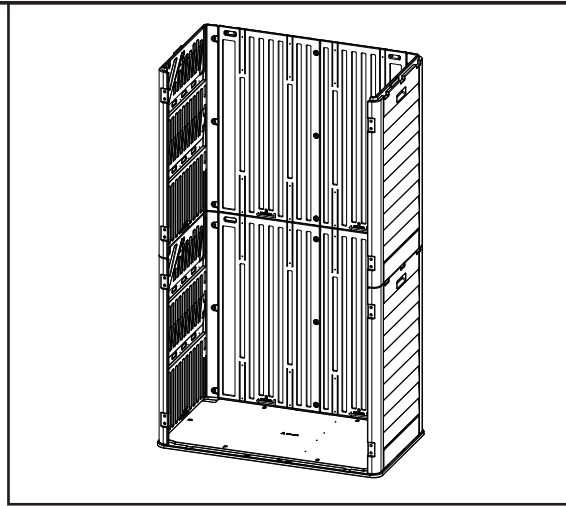

Take the Upper plates
B&C from Carton A

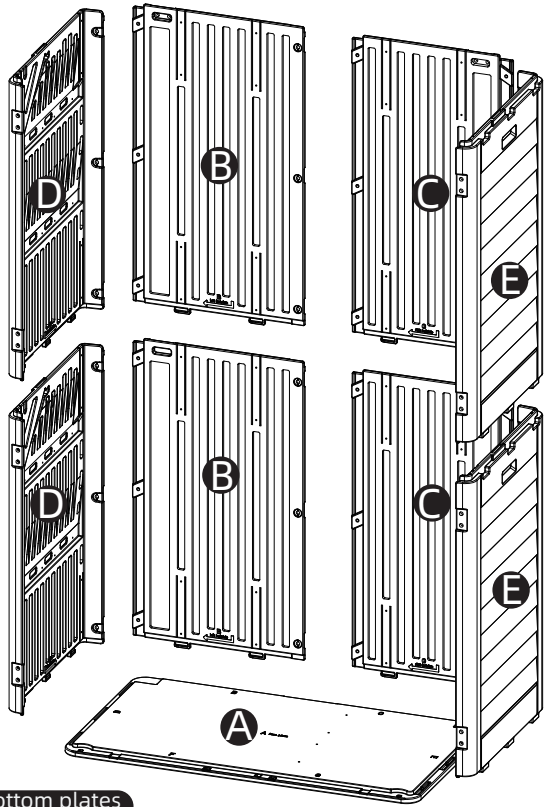

Take the Bottom plates
B&C from Carton B

Top2

FRONT&UPPER

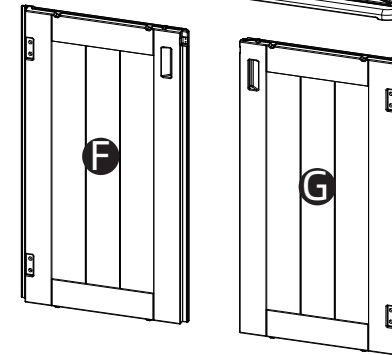
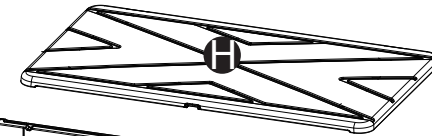
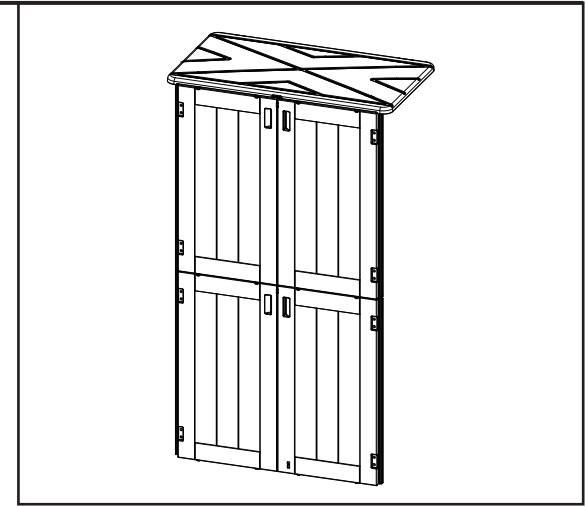



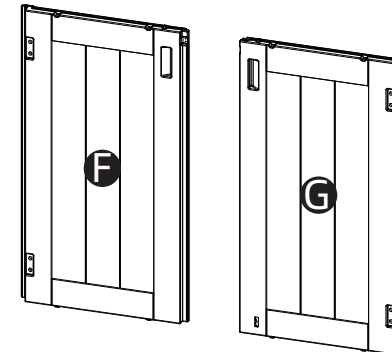

Take the Upper plates
G from Carton B



Take the Bottom plates
G from Carton A

PRODUCT ASSEMBLY

STEP1 BOTTOM BACK PLATES ASSEMBLY	B		x1	Carton No.B	C		x1	Carton No.B
	P		x3	B-2	Q		x1	B-2

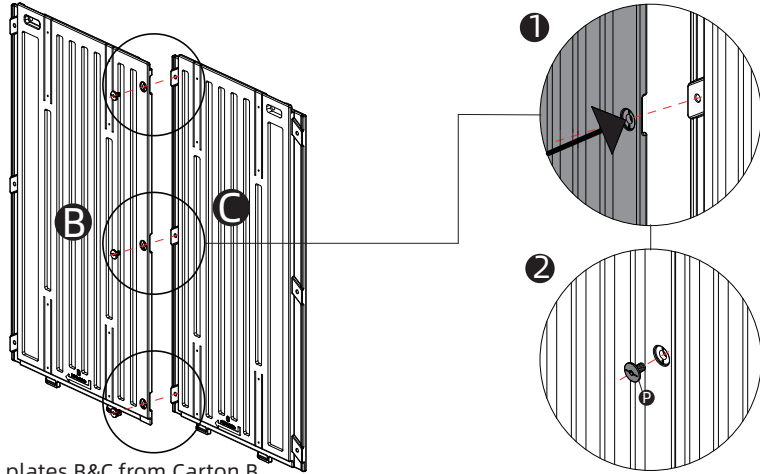

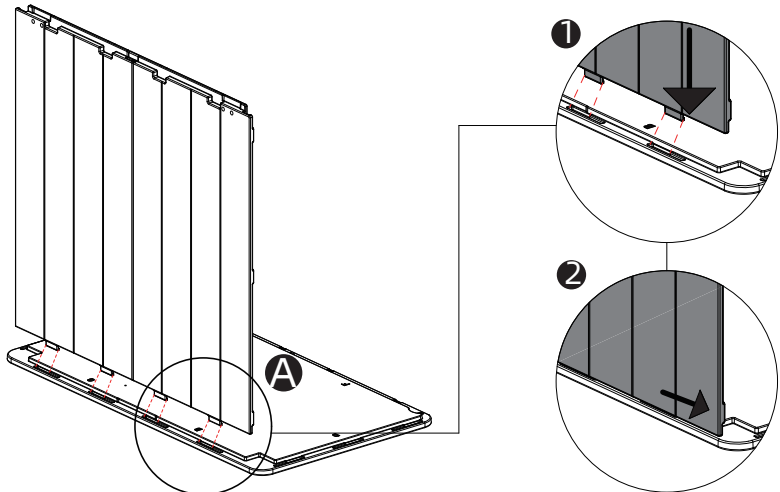

Note: Take the plates B&C from Carton B

STEP2 BOTTOM PLATE ASSEMBLY	A		x1	Carton No.A				





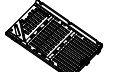
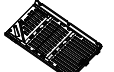

Note: Take the plates B&C from Carton B

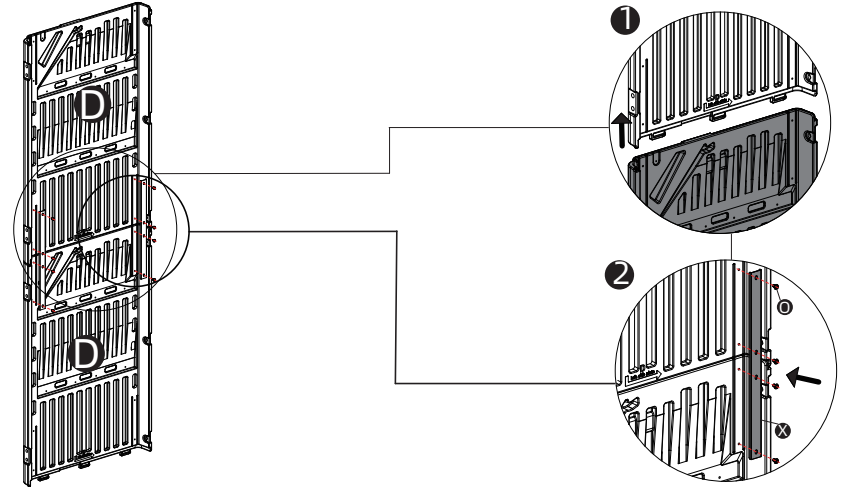
PRODUCT ASSEMBLY

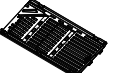
STEP3 LEFT SIDE PLATES ASSEMBLY	D		x1	Carton No.A	D		x1	Carton No.B
	O		x8	B-5	X		x2	B-5



STEP4 RIGHT SIDE PLATES ASSEMBLY	E		x1	Carton No.A	E		x1	Carton No.B
	O		x8	B-5	X		x2	B-5

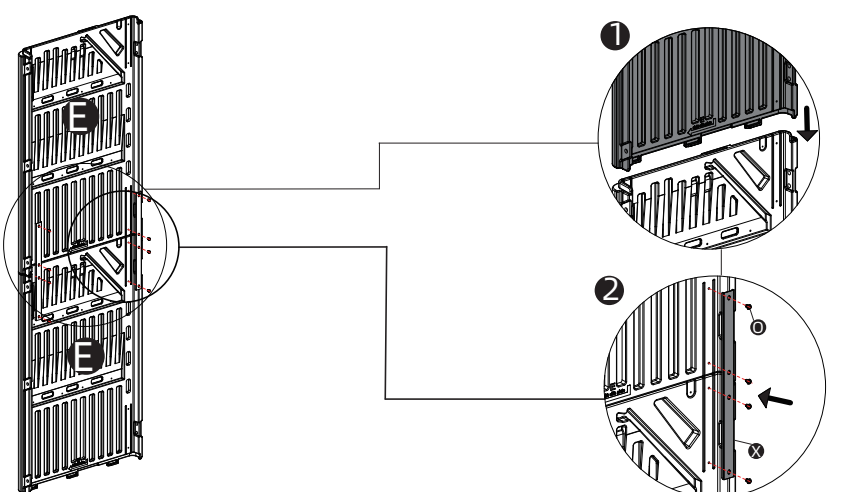

PRODUCT ASSEMBLY

STEP5

SIDE PLATES ASSEMBLY

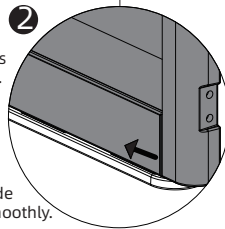
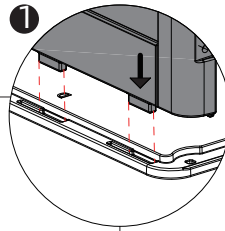
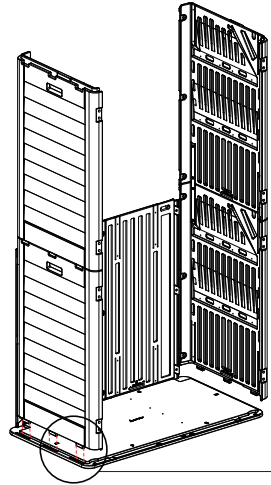

Note: Insert the side plates into the bottom first. Secondly push the side plates in the direction of arrow. Ensure that the plates are tilted 10 degrees to the outside to pass the bump smoothly.

STEP6

SIDE PLATES FIXATION

P		x6	B-2	Q		x1	B-2
---	--	----	-----	---	--	----	-----

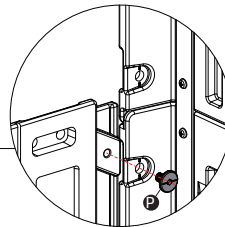
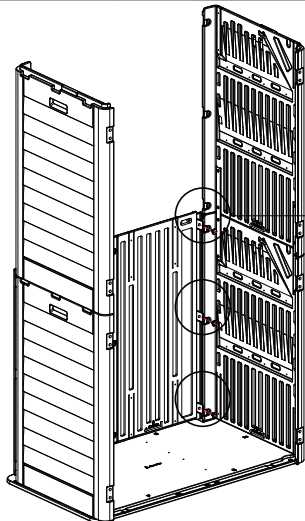

PRODUCT ASSEMBLY

STEP7

UPPER BACK PLATES ASSEMBLY

B		x1	Carton No.A	C		x1	Carton No.A
P		x3	A-2	Q		x1	A-2

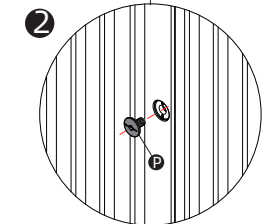
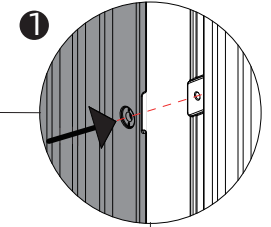
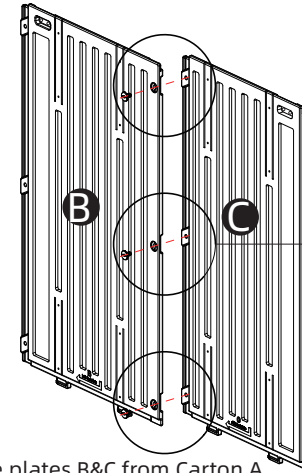

Note: Take the plates B&C from Carton A

STEP8

STEEL CONNECTORS ASSEMBLY

O		x8	B-5	X		x4	B-5
---	--	----	-----	---	--	----	-----

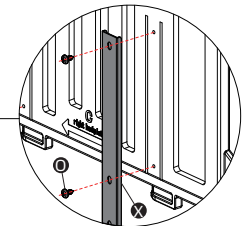
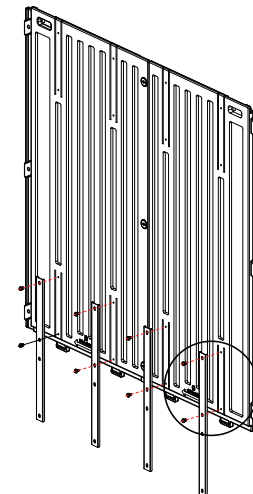

Note: Take the plates B&C from Carton A

PRODUCT ASSEMBLY

STEP9

BACK PLATES
ASSEMBLY

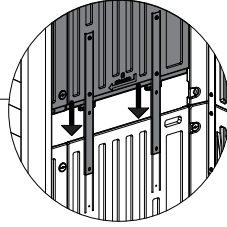
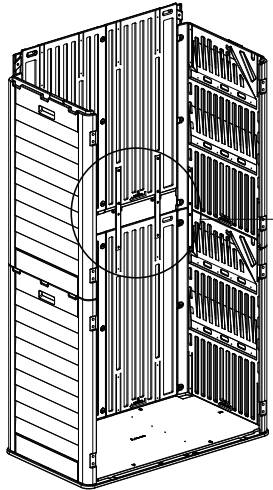

STEP10

BACK PLATES
FIXATION

P		x6	A-2	Q		x1	A-2
O		x8	B-5				

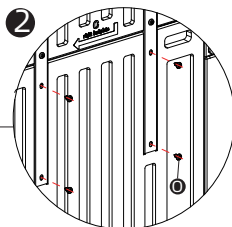
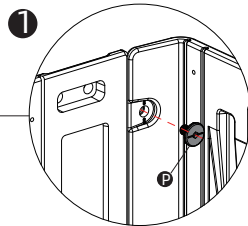
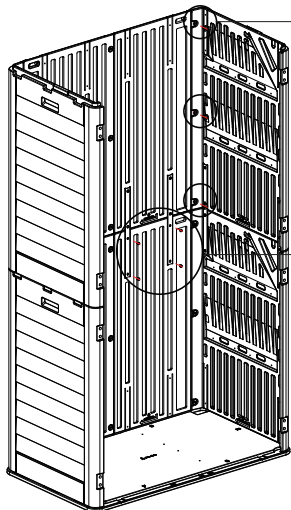

PRODUCT ASSEMBLY

STEP11

PARTS ASSEMBLY
FOR UPPER PLATE

H		x1	Carton No.A	M		x2	A-1
N		x2	A-1	O		x4	A-1
R		x1	A-3	S		x3	A-3

Note: Assemble the Hinge if needed

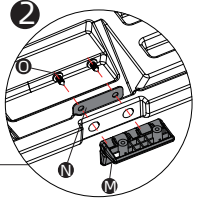
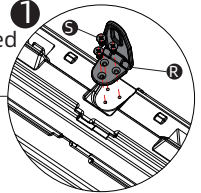
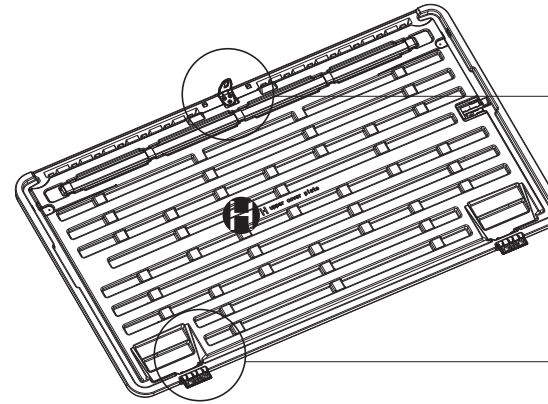

STEP12

UPPER PLATE
ASSEMBLY



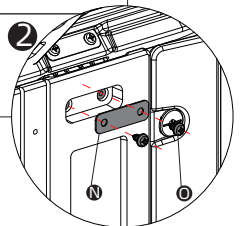
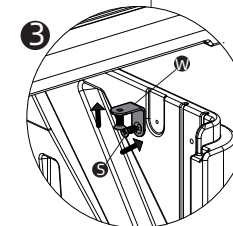
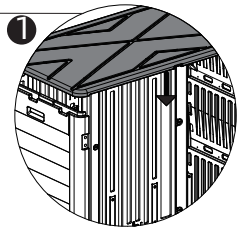
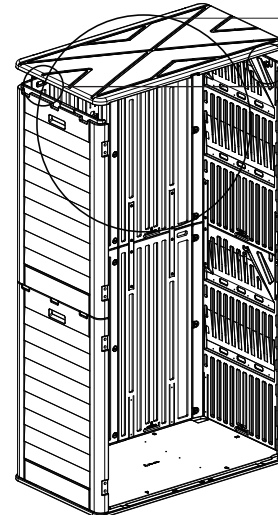

N		x2	A-1	O		x4	A-1
W		x2	B-4	S		x4	B-4



PRODUCT ASSEMBLY

STEP13

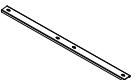

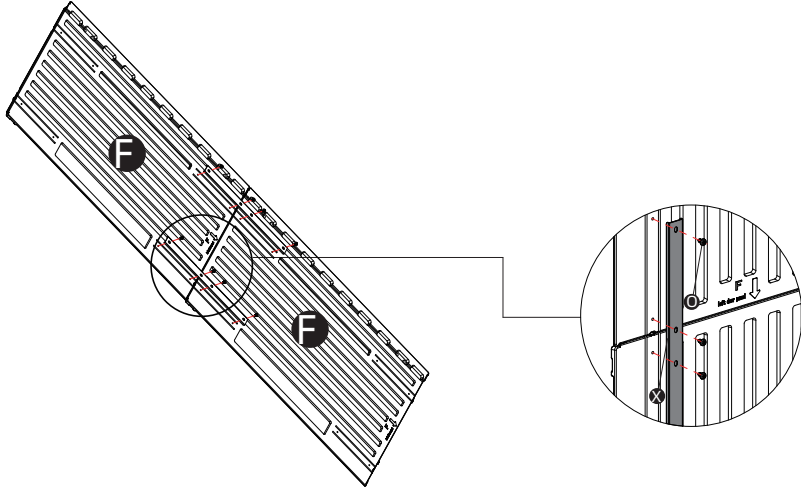

LEFT FRONT
PLATES
CONNECTION

F		x1	Carton No.A	F		x1	Carton No.B
X		x2	B-5	O		x8	B-5



STEP14

RIGHT FRONT
PLATES
CONNECTION



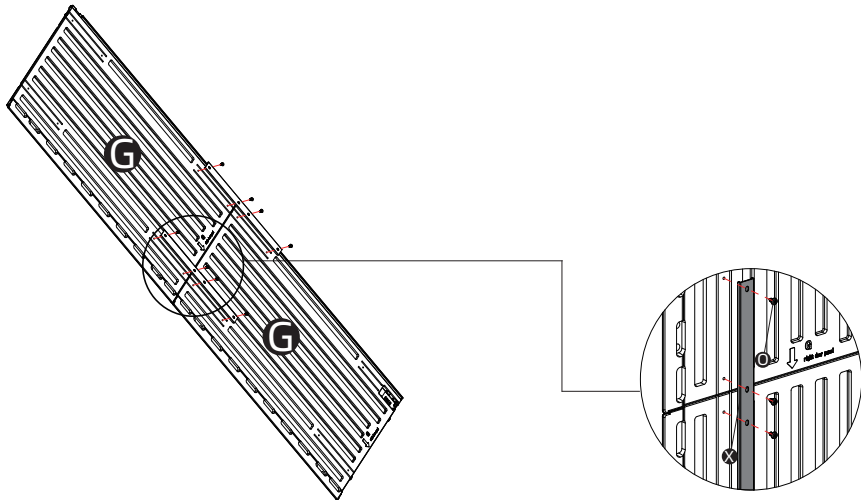

G		x1	Carton No.A	G		x1	Carton No.B
X		x2	B-5	O		x8	B-5



PRODUCT ASSEMBLY

STEP15

ACCESSORIES
OF LEFT FRONT
PLATES
ASSEMBLY



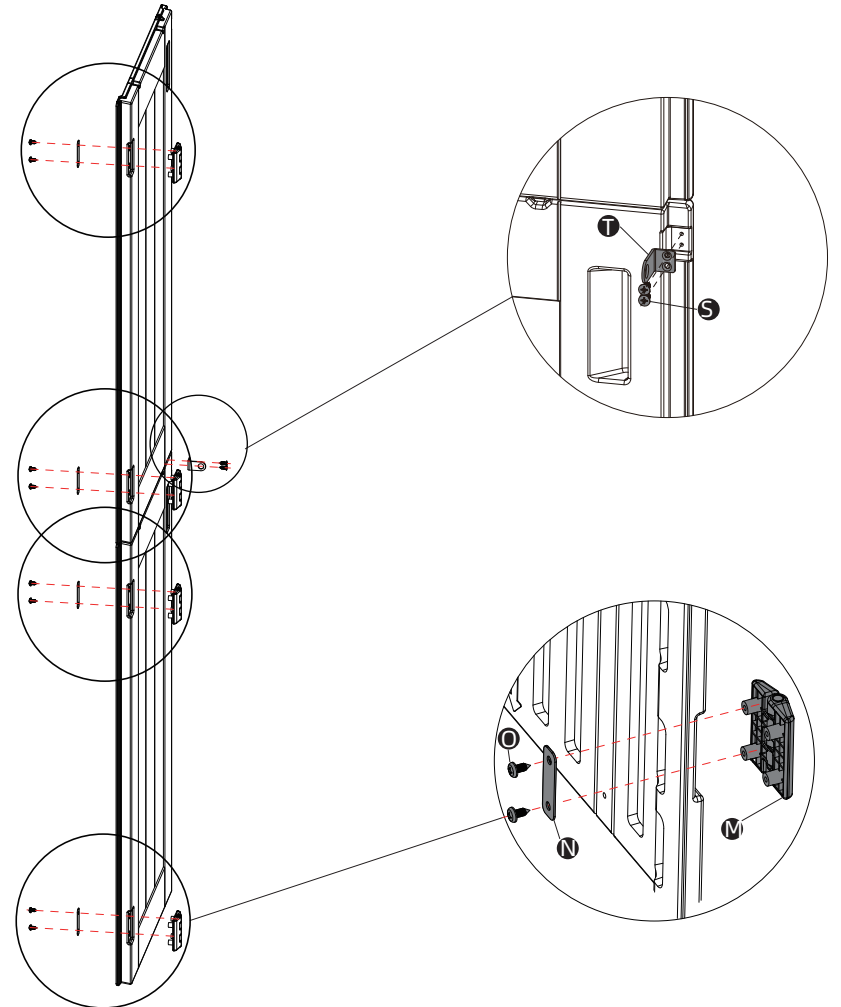



M		x4	A-1	N		x4	A-4
O		x8	A-1	T		x1	A-6
S		x2	A-6				

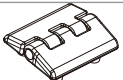
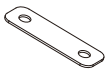

PRODUCT ASSEMBLY

STEP16

ACCESSORIES
OF RIGHT FRONT
PLATES
ASSEMBLY

M		x4	B-1	N		x4	B-1
O		x8	B-1	U		x1	A-6
S		x2	A-6	J		x1	A-4
K		x1	A-4				

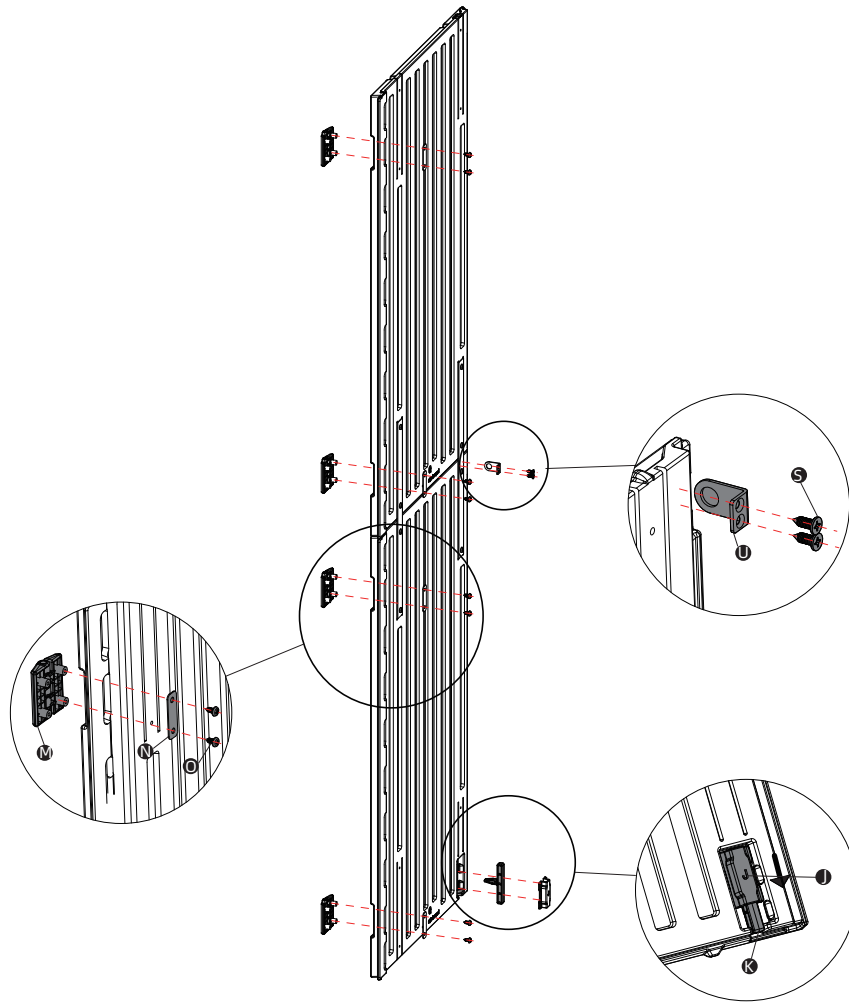

PRODUCT ASSEMBLY

STEP17

FRONT PLATES
ASSEMBLY

N		x4	A-1	O		x8	A-1
N		x4	B-1	O		x8	B-1

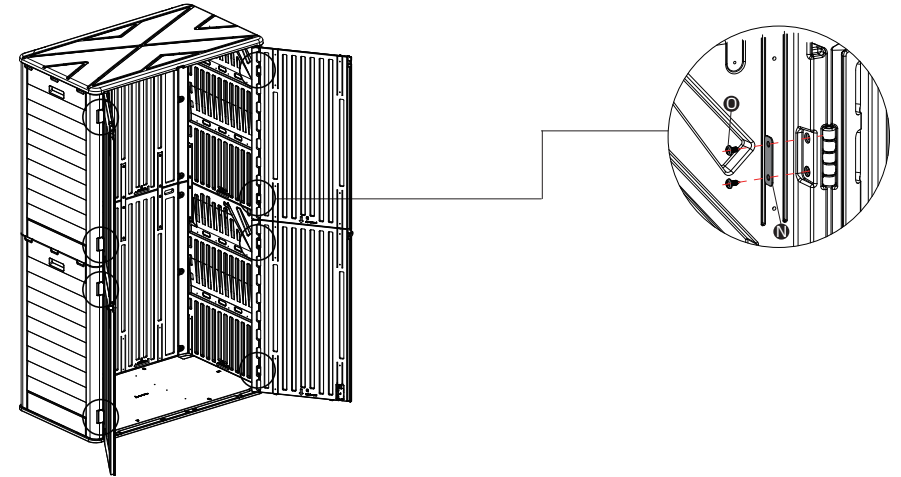

STEP18

BOTTOM PLATES
FIXATION

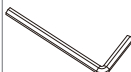
V		x4	B-3	Q		x1	B-2
---	---	----	-----	---	---	----	-----

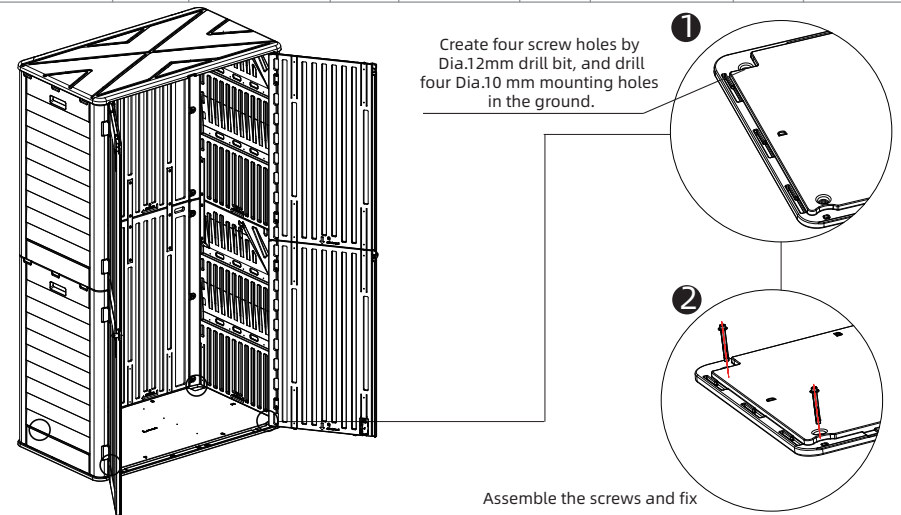

Congratulations! You have completed the installation of the storage shed.

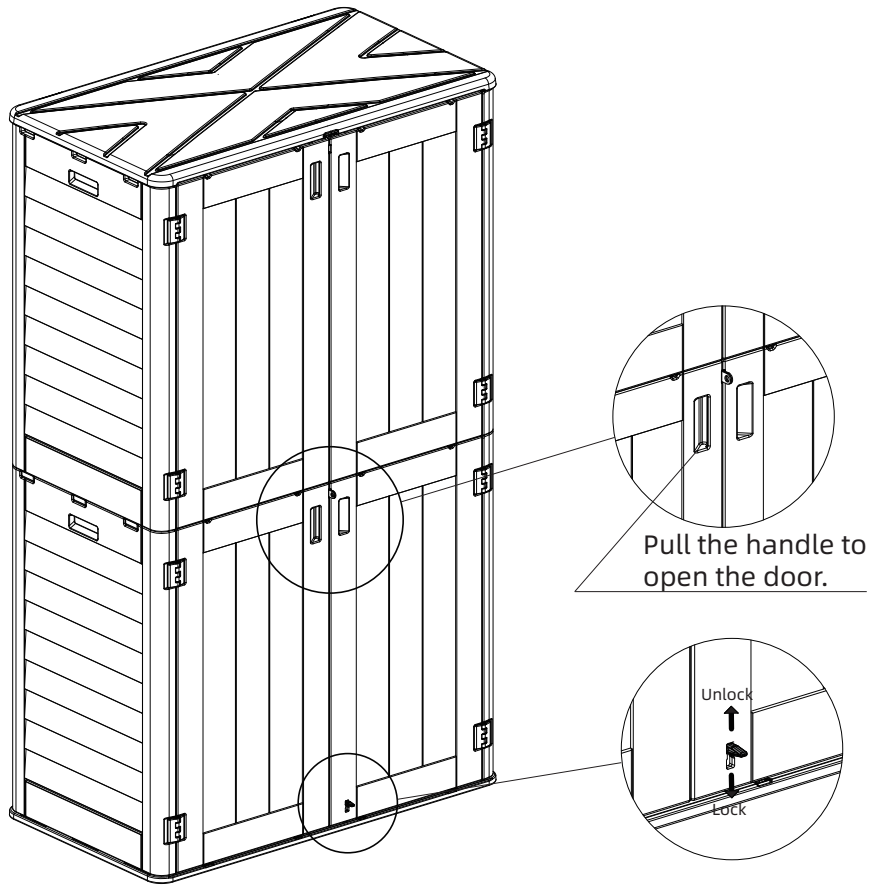

You can purchase metal shelves separately if you need.

Metal Shelves Kit
For Vertical Storage Shed

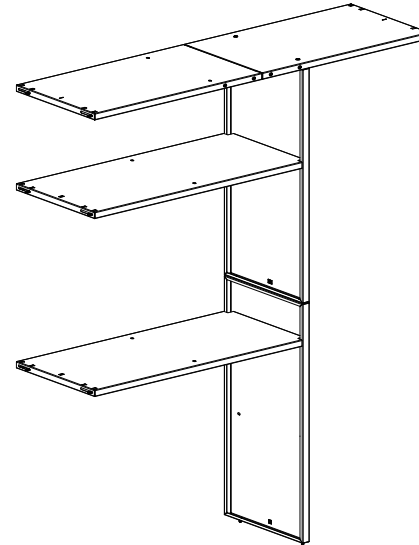

Display of finished assembly

